

# Whack N Win Service Manual

Innovative Concepts in Entertainment, INC

10123 Main Street  
Clarence, NY 14031

[WWW.ICEGAME.COM](http://WWW.ICEGAME.COM)

(716) 759-0360 I.C.E. Tech Support

# Table of Contents

Safety and Warnings	3
Game Assembly	4 - 8
Programming	9
Tower Score Charts	10
Service	
Upper Marquee Access	11
Changing Tower Score Values	12
Power Supply	13
Piezo Assembly replacement	
Tower Lighting	14
Spare Parts List	15
Warranty	16

## SAFETY AND WARNINGS BEFORE YOU BEGIN

WARNING: WHEN INSTALLING THIS GAME, A GROUNDED A.C. RECEPTACLE MUST BE USED. FAILURE TO DO SO COULD RESULT IN INJURY TO YOURSELF OR OTHERS. FAILURE TO USE A GROUNDED RECEPTACLE COULD ALSO CAUSE IMPROPER GAME OPERATION, OR DAMAGE TO THE ELECTRONICS.

**NOTE: THIS GAME IS INTENDED FOR INDOOR USE ONLY.**

DO NOT DEFEAT OR REMOVE THE GROUNDING PRONG ON THE POWER CORD FOR THE SAME REASON AS GIVEN ABOVE. USING AN IMPROPERLY GROUNDED GAME COULD VOID YOUR WARRANTY.

HAVE A QUALIFIED ELECTRICIAN CHECK YOUR A.C. RECEPTACLE TO BE SURE THE GROUND IS FUNCTIONING PROPERLY.

THIS GAME IS DESIGNED TO DISSIPATE STATIC ELECTRICITY THROUGH THE GROUNDING PLANE OF THE GAME. IF THE A.C. GROUND DOES NOT WORK, THE GAME COULD DISCHARGE STATIC ELECTRICITY THROUGH THE GAME CIRCUITRY, WHICH COULD CAUSE DAMAGE.

THE POWER SUPPLY IS NOT VOLTAGE ADJUSTABLE. TO OPERATE THE GAME AT VOLTAGES OTHER THAN THOSE IT WAS DESIGNED FOR. PLEASE CONTACT OUR SERVICE DEPARTMENT FOR VOLTAGE CONVERSION INFORMATION.

### WARNING

DO NOT remove any of the components on the main board (e.g. compact flash and EPROMS) while the game is powered on. This may cause permanent damage to the parts and the main board. Removing any main board component part while powered on will void the warranty.

ALWAYS REMOVE POWER TO THE GAME, BEFORE ATTEMPTING ANY SERVICE, UNLESS NEEDED FOR SPECIFIC TESTING. FAILURE TO OBSERVE THIS PRECAUTION COULD RESULT IN SERIOUS INJURY TO YOURSELF OR OTHERS.

THIS GAME IS NOT SUITABLE FOR INSTALLATION IN AN AREA WHERE A WATER JET COULD BE USED.

This appliance is not intended for use by persons (including children) with reduced physical, sensory or mental capabilities, or lack of experience and knowledge, unless they have been given supervision or instruction concerning use of the appliance by a person responsible for their safety. Children should be supervised to ensure that they do not play with the appliance.

The game's foot print is 42.5" w x 48" d x 136" h

### AC Power Information

The games main fuse is accessed through the back of the game at the power mod. Above the power cord is a small panel that contains the main fuse. The value of the fuse for 120 volt users is 3 AMPS at 250Volt type slow blow. The value of the fuse for 230 users is 1.5 AMPS at 250Volt type slow blow.

### Step 1:

Open bottom access panel to expose main board. Remove lower light housing panel to access wiring. Remove the upper light housing panel.

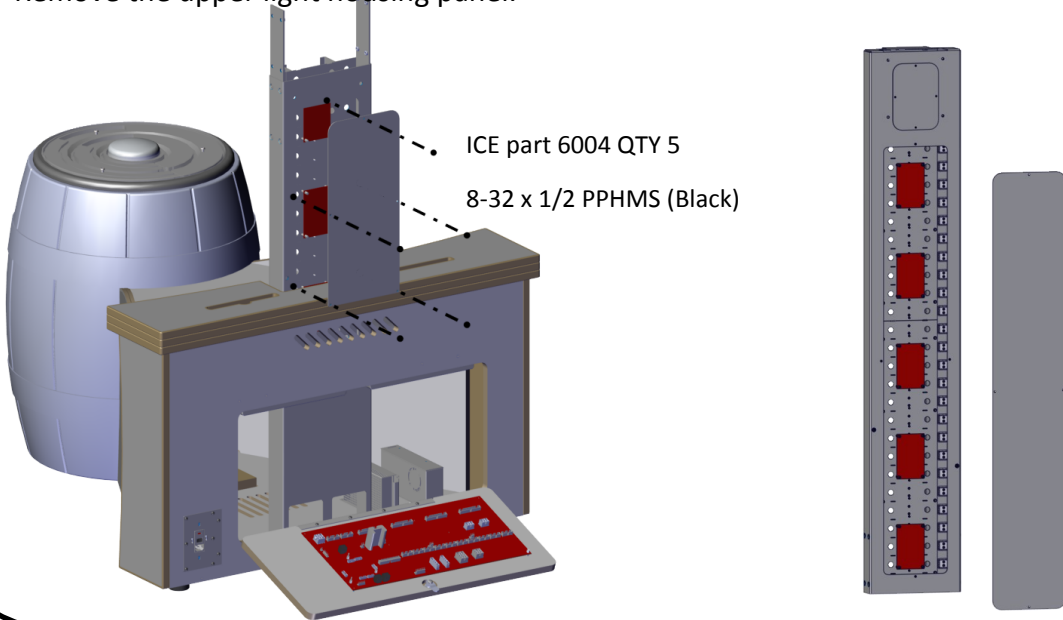

### Step 2:

Install 2 1/4—20 x 1 1/4 bolts half way in the light housing's guide tabs as shown with short arrows. Slide the light housing onto the base and stop and rest the tower on the 1/4-20 bolts. This will allow a space for you to work in running the wiring through to the cabinet base. Don't worry about the wiring at this time, just be careful not to pinch the harness.

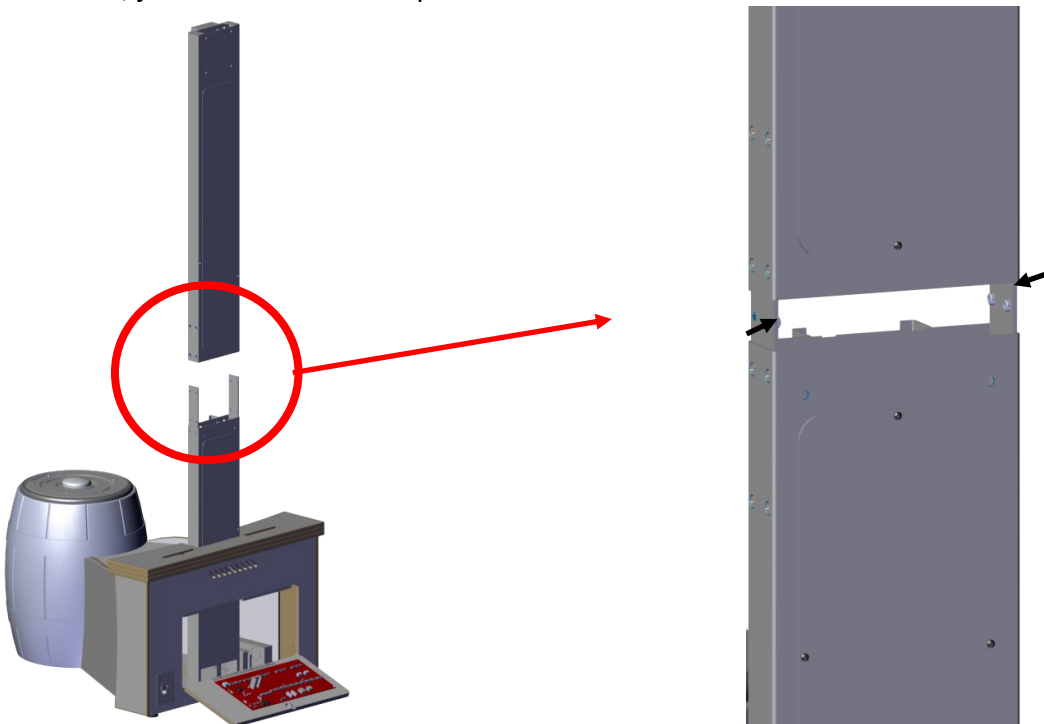

### Step 3:

Cut the wire tie shown and all the other below. This will allow you to take one connector harness at a time and insert it through to the bottom where the main board is located. Be careful not to snag and disconnect any other of the other wire harnesses while doing so.

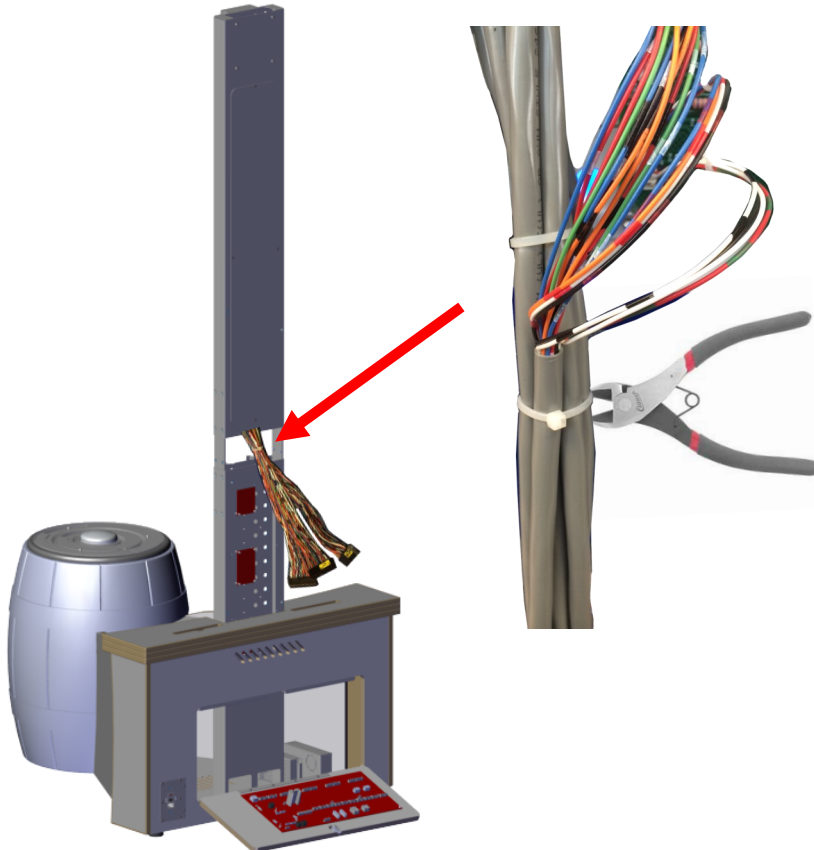

### Step 4:

Connect the five harnesses shown below that connects the middle section to the base section. They are color coded.

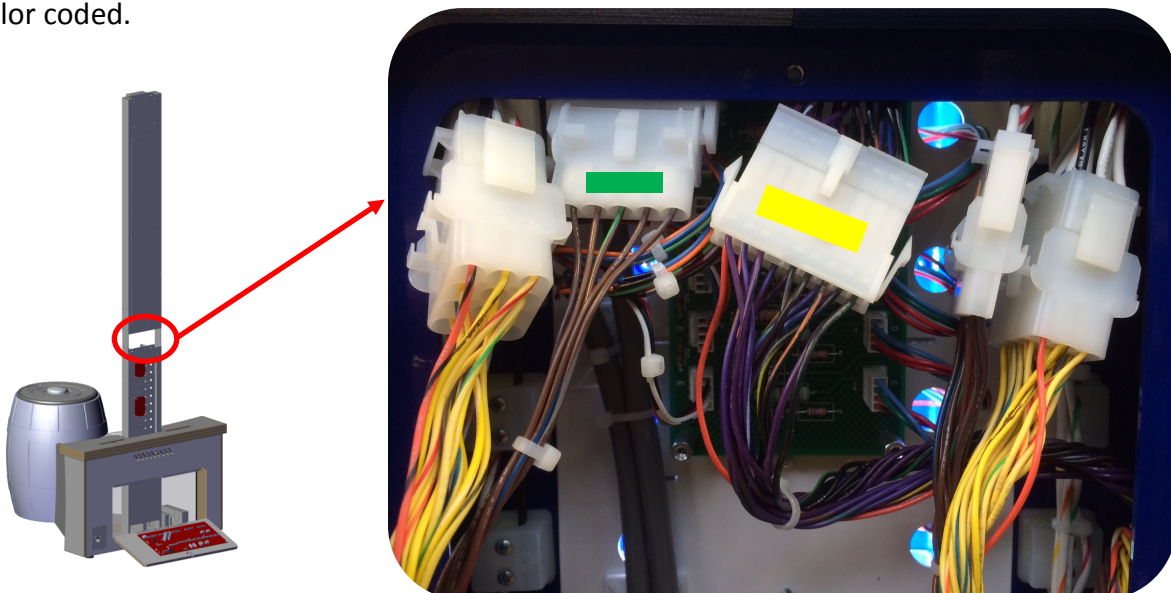

### Step 5:

While holding the upper light housing remove the two 1/4-20 x 1-1/4 screws using a # 3 Phillips screw driver on each side and slide the light housing down being careful not to pinch any of the wire harnesses. Attach the light housing using four flat screws on each side (only one side is shown in the diagram).

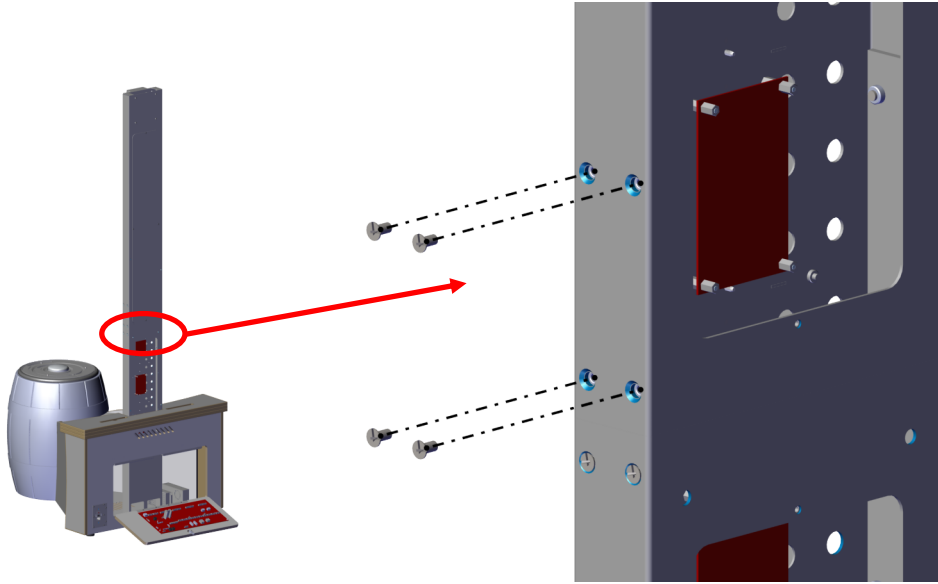

### Step 6:

Before lifting the bonus marquee up to the top, open the access door using a 45 key. Put the door aside. Slide the marquee assembly onto the top of the light housing and connect the harness shown below.

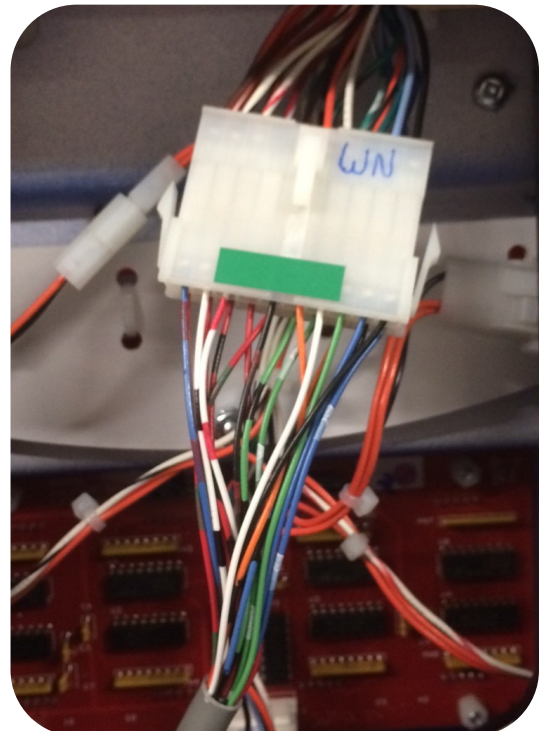
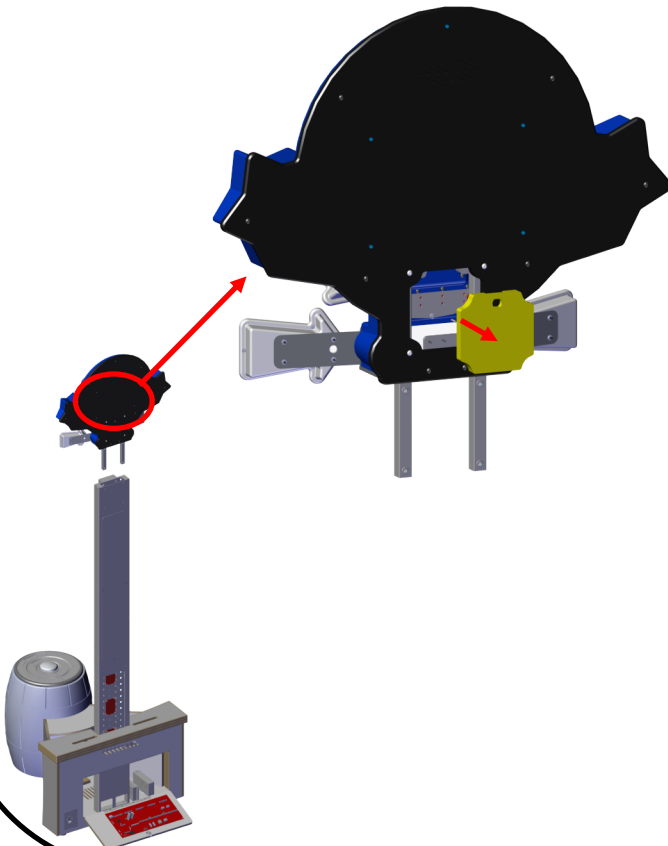

### Step 7:

Attach the Bonus Marquee using four Allen bolts. Replace the access panel door.

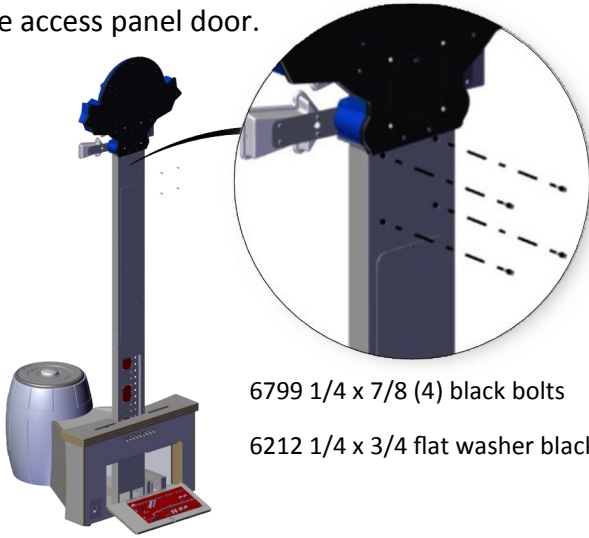

6799 1/4 x 7/8 (4) black bolts  
6212 1/4 x 3/4 flat washer black

### Step 8:

From the back of the game, attach the right side balloons using three Allen bolts and washers.

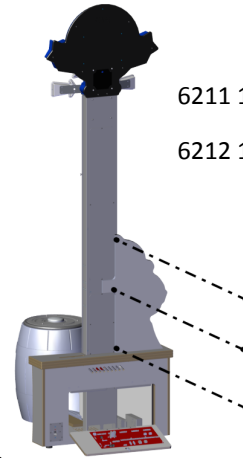

6211 1/4-20 x 1 1/4(3) black bolts  
6212 1/4 x 3/4 flat washer black

### Step 9:

From the back of the game install the right side balloon. Before lifting onto the cabinet, remove the bottom wire channel to access the harness. Attach with three Allen bolts and washers. Connect the wire harness from the balloon to the base.

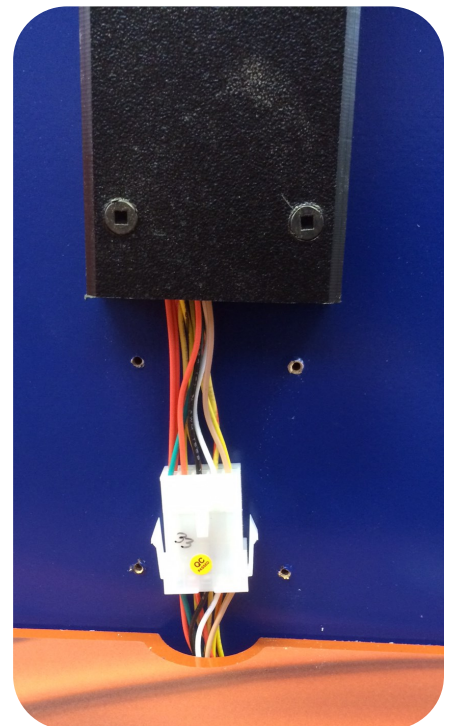
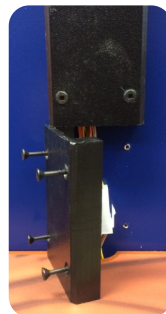
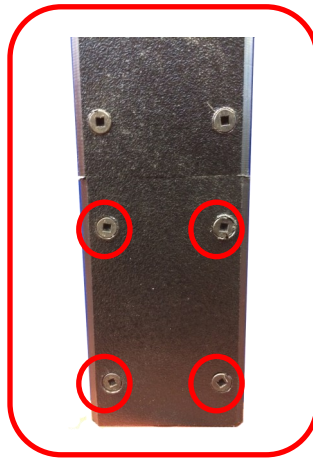
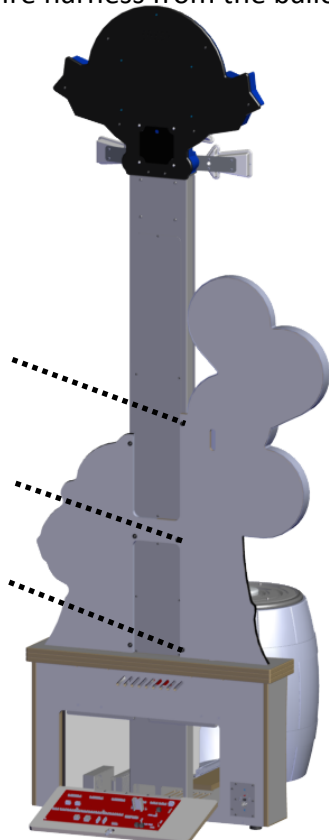

### Step 10:

Connect the light housing harnesses to J23, J24, and J25. The harnesses are labeled.

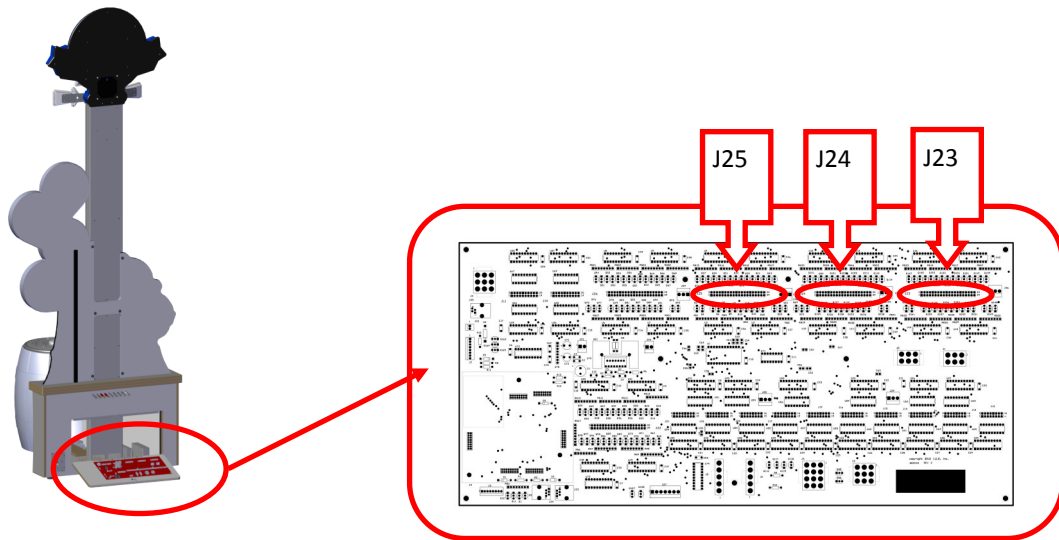

### Final:

Align the Playfield score graphic and Clear protective shield together and attach using 18 Phillip screws. You will need to remove the protective film from the plastic before you install.

Start at the top and continue down in pairs. Do not tighten any screws until all of the screws have been installed.

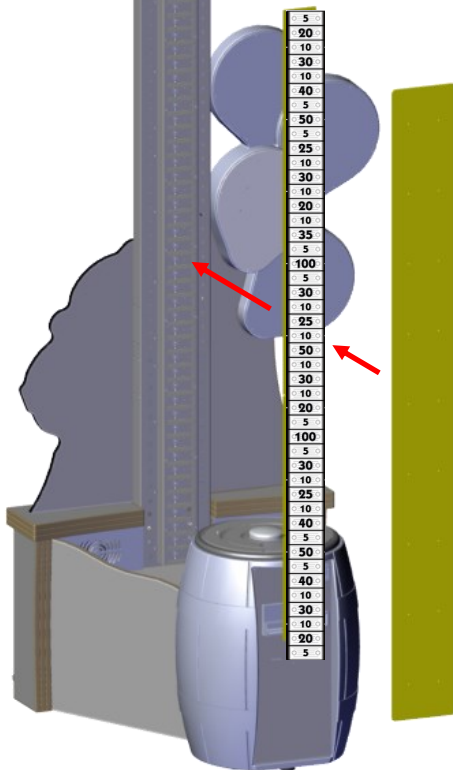

6663 6/32 x 5/8 (18) Silver Phillips

Now that your game is assembled it is time to set some options. The game's scoring is shown on the Tower Score Chart and it is based on price per play. The game can be ordered with .50¢, \$1.00, \$1.50, or \$2.00 Tower Score Chart installed. You cannot change the values used in the Tower Score Charts. You can change the bonus amount and how much to charge per play.

To determine which Tower Score Chart the game is using when the power is applied to the game, the balloon to the right will display which Tower Score Chart it is using. The display at the top shows the software version. If you desire to change the Tower Score Chart you will need to contact ICE Service Department and order both the software and Tower Score Chart.

Open the cabinet's lower drawer and at the back you will find the user control panel. Pressing the "PROG" button will enter the programming mode. The lower right balloon shows which option you are adjusting while the upper display shows the value for that option. Pressing the "SELECT" button will advance to the next option. The "UP" and "DOWN" buttons will change the option's value.

### Programming Options for Wack N Win Revision 1.03

Option	Min	Max	Inc		
0	Game Volume	0	7	1	Game Volume
1	Music Volume	0	7	1	Music Volume
2	Coin 1	0	10	1	Cost of Game
3	Coin 2	0	10	1	# of Coin 1's
4	DBV	0	10	1	# of Coin 1's
5	Discount	0	10	1	# of Games till Discount
6	Games Discounted	0	20	1	Games Given if Discount
7	Attract Time	0	90	1	Attract time
8	Sensitivity	1	15	1	Hit pad Sensitivity, the lower the number the more sensitive the pad becomes.
9	Window	1	6	1	Bonus Window, where a setting of 1 is the hardest setting.
10	Bonus Tickets	25	5000	25	Tickets for Bonus Score
11	Scoring Table	1	6	1	Tells the game which tower score chart to use. See below.
12	Ticket Multiplier	2	1	1	0 = JFF, 1 = 1/1 Ticket, and 2 = 1/2 tickets
13	Factory Reset	0	1	1	Factory Reset

**\*\* Note for Option 11 \*\* Refer to the next page for option number. This must match your score table!**

The recommended settings for the ticket bonus values are:

.25¢ = 100 tickets

.50¢ = 500 tickets

\$1.00 and \$1.50 = 1000 tickets

\$2.00 = 2000 tickets

The next page shows the Tower Score Charts and their coin values.

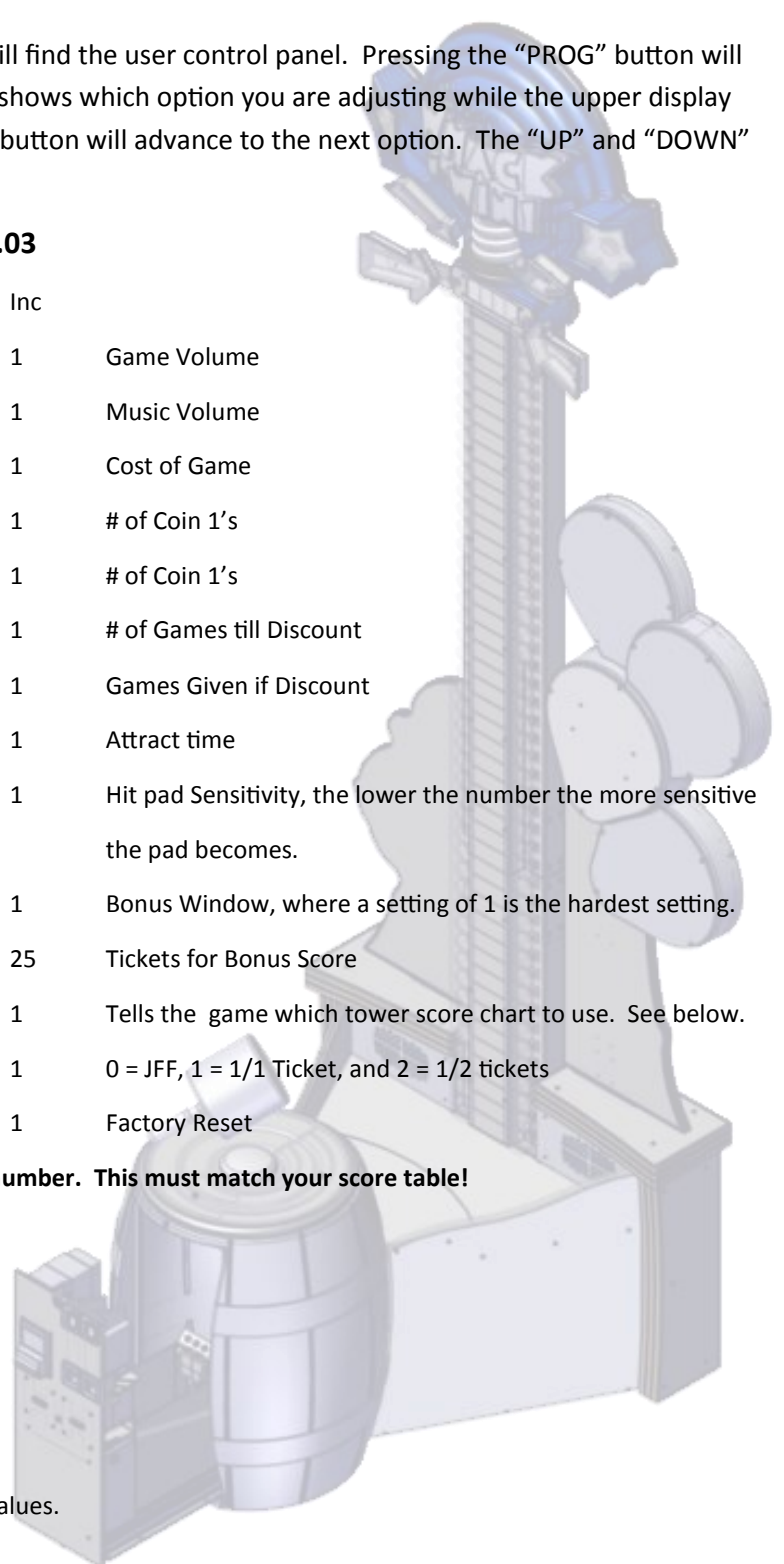



## Accessing Upper LED light strips and Display Board

To gain access to the electronics found inside the upper marquee, you will need to remove the upper marquee. Remove the four 1/4-20 x 7/8 bolts and washers holding the marquee in place (1). Open the back access door and unplug the harness (2 + 3). Lift the marquee up and place the marquee face down onto a table (4).

Remove the Square bit screws around the outside of the marquee (5). Using a wrench on the inside, remove the two lower 1/4-20 Allen bolts (6). Now separate the back assembly from the front (7).

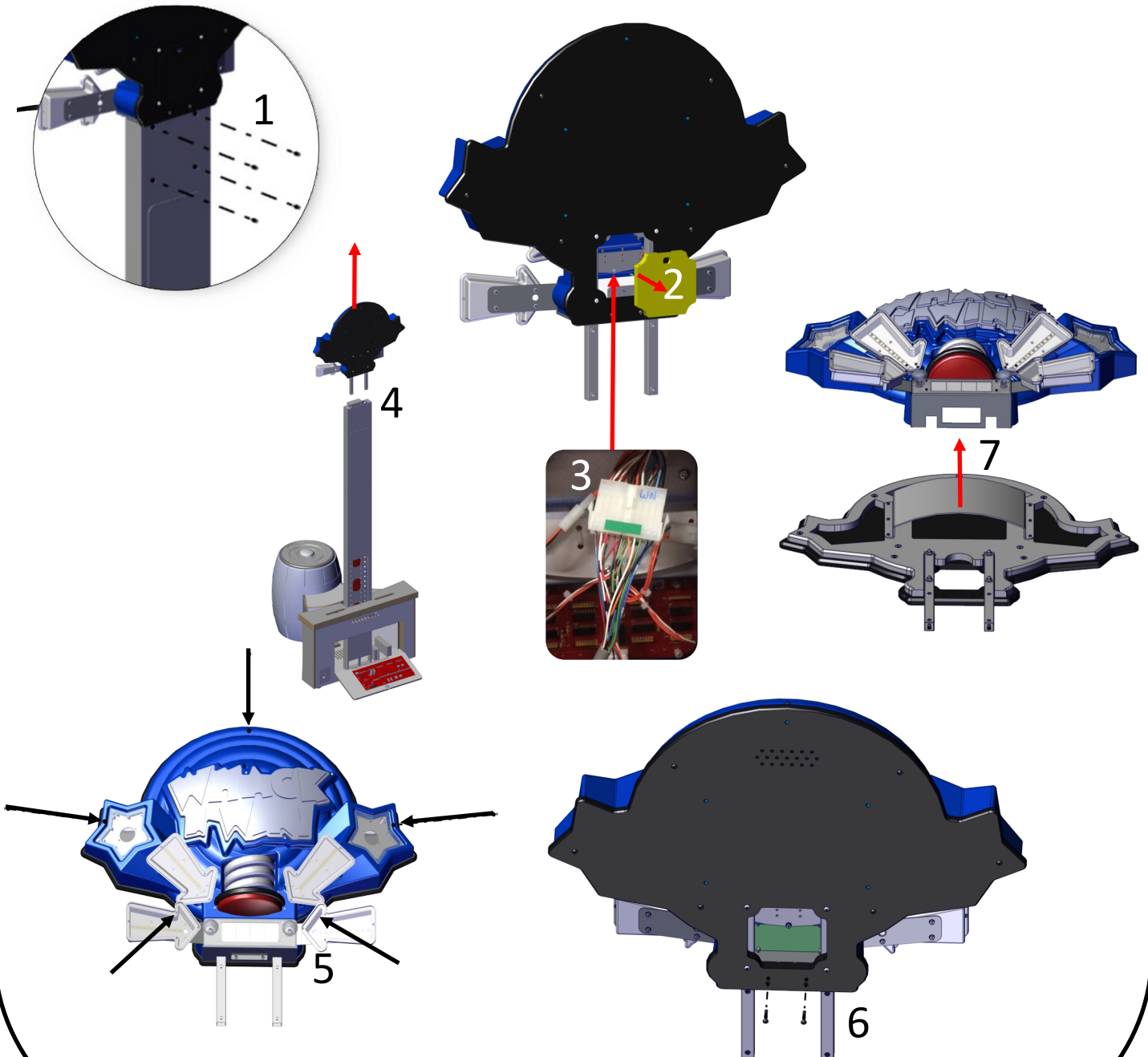

## Changing the Tower Score Card's Values

To change the Tower Score Card, remove the plastic shield and old Tower Score Card. Starting from the top, reinstall the silver Phillips screws. Then open the back access panel and remove the CPU brain board and replace it with the new one. The compact flash card only contains the audio files which are the same no matter what version you install.

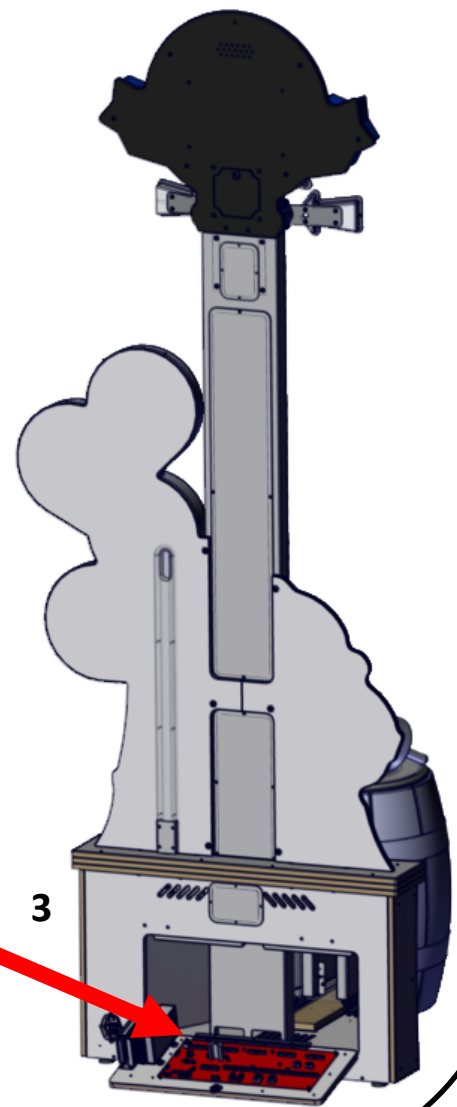
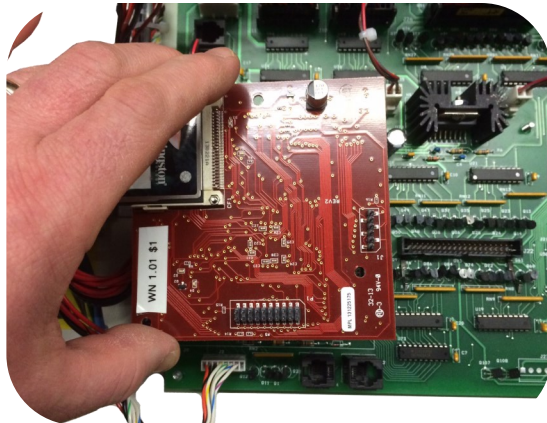
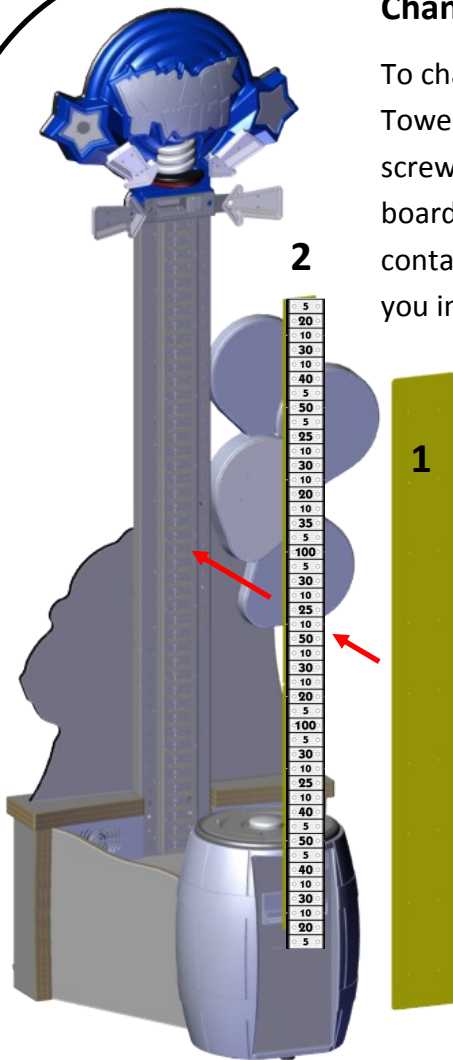

## GAME POWER SUPPLIES

There are two power supplies located at the back of the game. The IA2010 power supply provides the +12 DC volts to the game board, lights, and outer Fun lights. The WN2010 power supply provides the +5 DC voltage for the game logic and center LEDs.

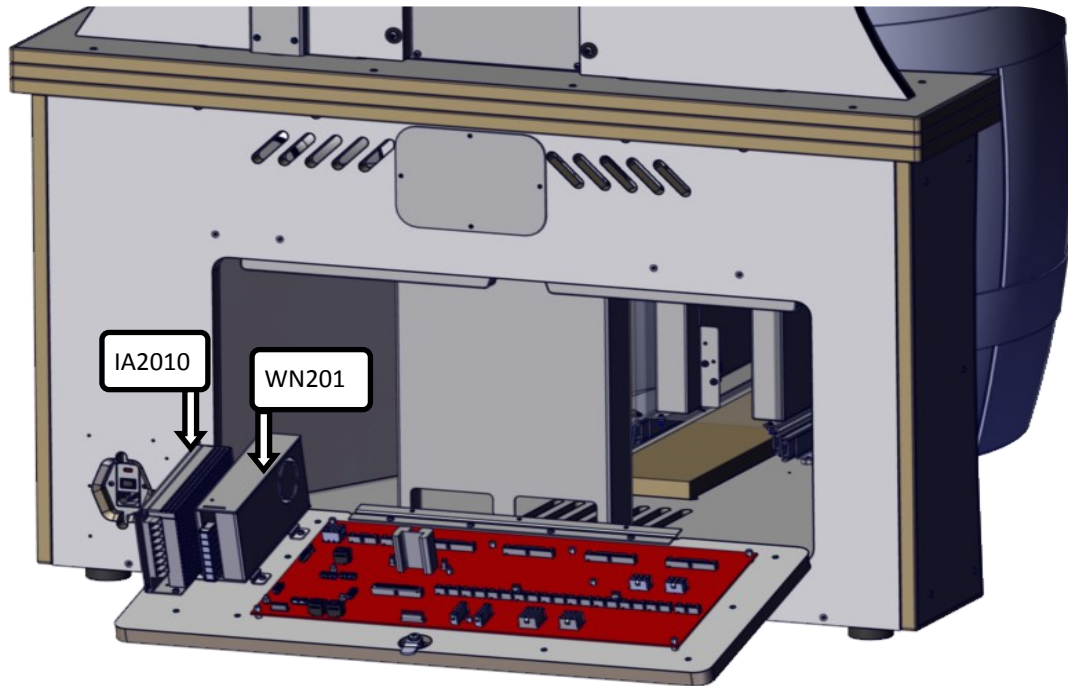

## WN1052X Piezo Sensor Assembly Replacement

Open the bottom drawer and from underneath the barrel's top remove the three bolts labeled as A,B, and C (1). Unplug the harness and lift the assembly out. When replacing, use the upper hole to feed the wire harness through.

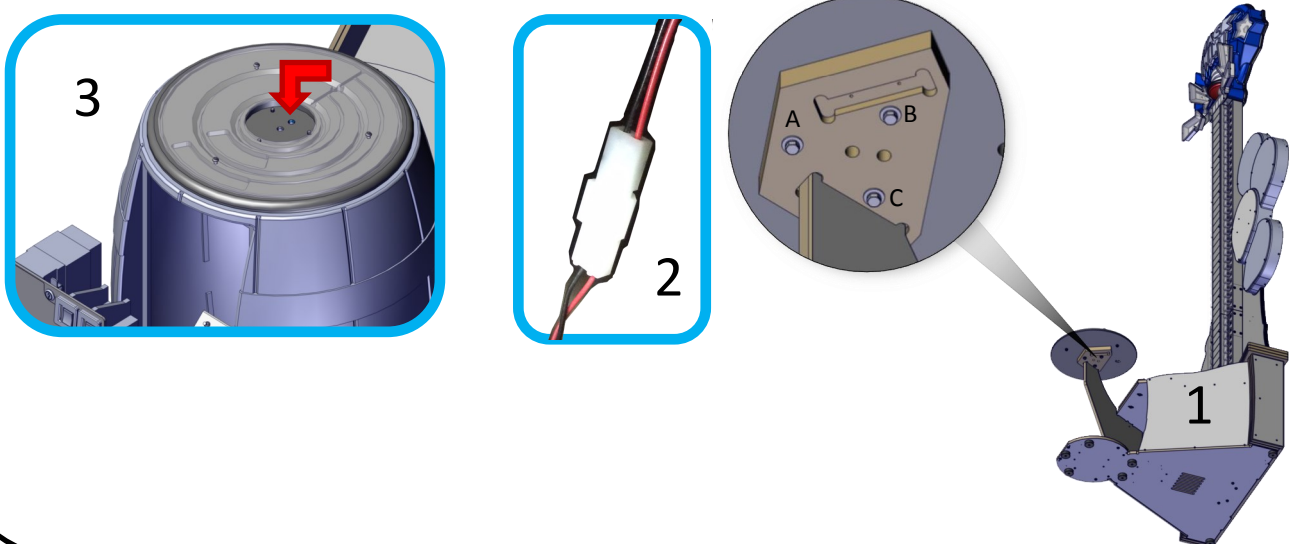

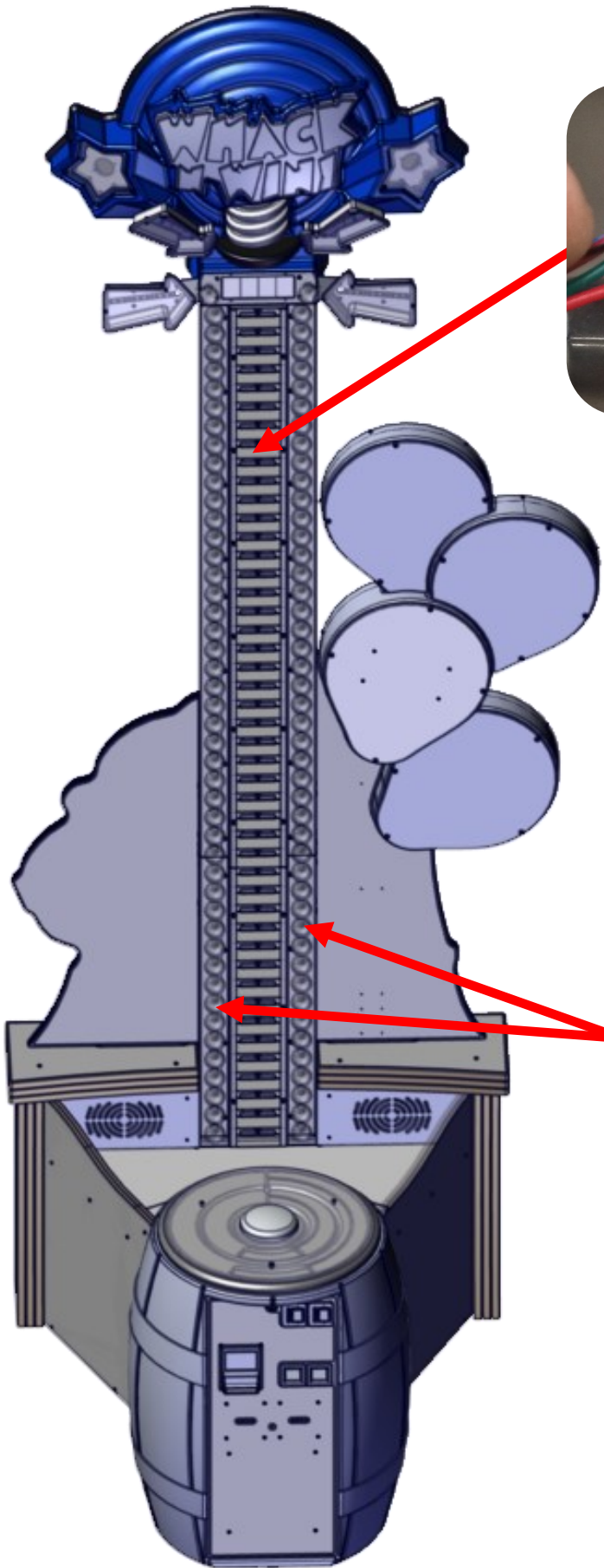

E00869W NX

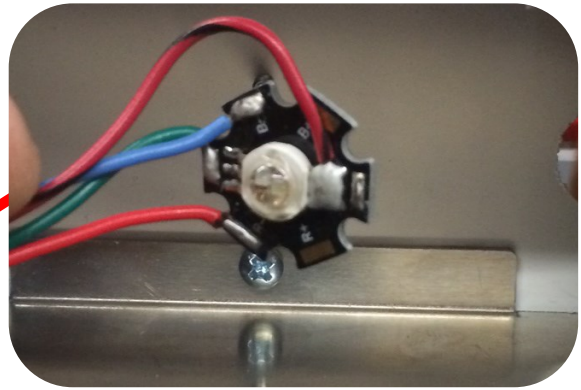

+5 volt LED Lights are mounted with the red w/brown wire loop at the top, over the mounting screw. **HAND TIGHT PLASTIC NUTS!**

**DO NOT USE POWER TOOLS TO INSTALL!!**



+12 volt LED Fun Lights. To access the bulb, unscrew the plastic cover.

# Spare Parts List

WN2051HX	HARNESS (MAIN)
WN2052HX	HARNESS (COIN DOOR)
WN2060LX	HARNESS (DC POWER)
WN2063LX	HARNESS (5V DC POWER)
WN2064LX	HARNESS (POWER SUPPLY AC)
WN2080LX	HARNESS (RGB EXTENSION 1-5)
WN2081LX	HARNESS (RGB EXTENSION 6-15)
WN2082HX	HARNESS (RGB EXTENSION CABLES)
WN2085HX	HARNESS (FUN LIGHTS EXTENSION A)
WN2086MX	HARNESS (FUN LIGHTS EXTENSION B)
WN2087HX	HARNESS (FUN LIGHTS)
WN2097ELX	HARNESS (MARQUEE EXTENSION)
WN2097ILX	HARNESS (MARQUEE INTERFACE)
WN2098LX	HARNESS (BALLOON LEDS/BONUS DISP
E00418WNAX	ASY (WHITE 27 LED TAPE STRIP)
E00724WNAX	ASY (RGB 81 LED TAPE STRIP)
E00724WNBX	ASY (RGB 54 LED TAPE STRIP)
E00724WNX	ASY (RGB 27 LED TAPE STRIP)
E00788WNBX	ASY (WHITE LRG 60 LED STRIP)
E00843	LED, E10, CLUSTER OF 12 (MEDIUM)
E00869WNX	ASY (5V RGB LED, PCB CONN)
E2034XX	PCBA (BRAIN BOARD W/ 8716 FLAS
IA2010	POWER SUPPLY +12VDC 10A (ROHS)
IA4004	ROPE 6mm Blue
MA3006	T MOLDING (25/32 YELLOW) 105-2
PE1350	DRAWER SLIDE 18
PW2007PG	GREEN NEON MINI FUNLIGHT BULB
TA2032X	PCBA (DISPLAY)
TX2007X	ASY (POWER MODULE 5 AMP)
VW2053HX	HARNESS (TICKET DRAWER)
WN2010	POWER SUPPLY (5VDC, 40A)
WN2034X	PCBA (I/O)
WN2035X	PCBA (RESISTOR)
WN3002	CONTROL LED PANEL
WN4010	MALLET
WN7000	DECAL (FRONT DOOR) COUPONS
WN7002	DECAL (SIDE LEFT)
WN7003	DECAL (SIDE RIGHT)
WN7005	DECAL (REAR CABINET SIDE)
WN7007	CONTROL PANEL (MAT/PRINT)
WN7008	DECAL (REAR CABINET TOP LEFT)
WN7009	DECAL (REAR CABINET TOP RIGHT)
WN7010	DECAL (CARNIE BACKGROUND LEFT)
WN7011	DECAL (CARNIE BACKGROUND RIGHT)
WN7013	SPEAKER COVER (MAT/PRINT)
WN7014	PLAYFIELD (MAT/PRINT) \$.50
WN7025	BALLOON RED (MAT/PRINT)
WN7026	BALLOON BLUE (MAT/PRINT)
WN7027	BALLOON PURPLE TICKET (MAT/PRINT)
WN7028X	ASY MARQUEE
WN7029	BALLOON GREEN (MAT/PRINT)



# WARRANTY POLICY

I.C.E. Inc warrants all components in new machines to be free of defects in materials and workmanship for the period listed below:

- 180 days on Main PCB's, Computers & Motors
- 1 year on all LCD monitor panels
- 90 days on all other electronic and mechanical components
- 30 days on all I.C.E. repairs and parts purchases

I.C.E. Inc shall not be obligated to furnish a warranty request under the following conditions:

- Equipment or parts have failed through normal wear and tear
- Equipment has been subjected to unwarranted stress, abuse or neglect
- Equipment has been damaged as a result of arbitrary repair/modification

Products will only be covered under warranty by obtaining an I.C.E. authorized RMA #. To obtain an RMA # please provide I.C.E. tech support with the game serial # or original I.C.E. invoice # and a detailed description of the failure or fault symptoms.

I.C.E. Inc will assume no liability whatsoever for costs associated with labor or travel time to replace defective parts. All defective warranty covered components will be replaced with new or factory refurbished components equal to OEM specifications.

I.C.E. Inc will cover domestic UPS ground, or comparable shipping costs during the warranty period. International or expedited shipments are available for an additional charge. To obtain credit defective parts must be returned to I.C.E. Inc, at the customer's expense, within 30 days. After 30 days a 15% re-stocking fee will apply to all returns.

ICE distributors are independent, privately owned and operated. In their judgment, they may sell parts and/or accessories other than those manufactured by I.C.E. Inc. We cannot be responsible for the quality, suitability or safety of any non-I.C.E. part or modification (including labor) that is performed by such a distributor.

Innovative Concepts in Entertainment

**10123 Main St.**

**Clarence, NY 14031**

**Phone #: (716) - 759 – 0360**

**Fax #: (716) – 759 – 0884**

**[www.icegame.com](http://www.icegame.com)**