

Water Blast

FEC

OWNER'S MANUAL

(Version 1 Programming)



WARNING

Be sure to read this Operation Manual before using your machine to ensure safe operation.



©2012 Bob's Space Racers, Incorporated
427 15th Street
Daytona Beach, Florida 32117
Tel: 386-677-0761
Fax: 386-677-0794

WATER BLAST™ (FEC)



TABLE OF CONTENTS

1. INTRODUCTION

- 1-1. Overview and Technical Features:
- 1-2. Important Safety Information:
- 1-3. Game Operation
 - 1-3-1. Automatic Operation:
 - 1-3-2. Manual Operation:

2. PROGRAMMING

- 2-1. Entering Programming Mode:
- 2-2. Volume:
- 2-3. Coins per Credit:
- 2-4. Attract Mode:
- 2-5. Just for Playing Tickets:
- 2-6. Winner Tickets:
- 2-7. Game Time to Win:
- 2-8. Time Out:
- 2-9. Drain Water:
- 2-10. Link ID:
- 2-11. Money:
- 2-12. Reset Defaults:
- 2-13. Programming Options:
- 2-14. Reprogram Linking Games (Also covers how to reset settings):

3. MAINTENANCE AND TROUBLESHOOTING

- 3-1. Quick Troubleshooting:
- 3-2. Detailed Troubleshooting and Repair:
 - 3-2-1. Glass Cleaning:
 - 3-2-2. Cleaning Gun Parts:
 - 3-2-3. Target Sensors:
 - 3-2-4. Display P.C. Board Removal and Installation:
 - 3-2-5. Display P.C. Board Servicing:

4. PARTS LISTINGS

5. SCHEMATICS

6. WARRANTY

1. INTRODUCTION

1-1. Overview and Technical Features:

Thank you for purchasing the new WATER BLAST™ (FEC) from Bob's Space Racers®. Built on a long tradition of value, the WATER BLAST™ (FEC) retains all of the great game play you have come to expect from a game from BSR. It has been designed and engineered by taking years of experience in producing industry leading Water games and combining this experience with modern manufacturing technology developed for this application. All of this is brought together to provide the operator and customer with the best possible experience.

FEATURES

WATER – The water tank is an enclosed re-circulating system designed to be easy to maintain and service. It also features the low water warning light as a safety feature and reminder to fill the water.

WATER PUMP ASSEMBLY - The water pump assembly uses an all plastic impeller and housing to completely eliminate any rusting or corrosion in the water system. This greatly extends the time between water changes. The pump assembly also uses a basket type washable water filter in a clear-view housing to keep the game working properly. The entire pump assembly can be easily removed from the game making bench top servicing possible.

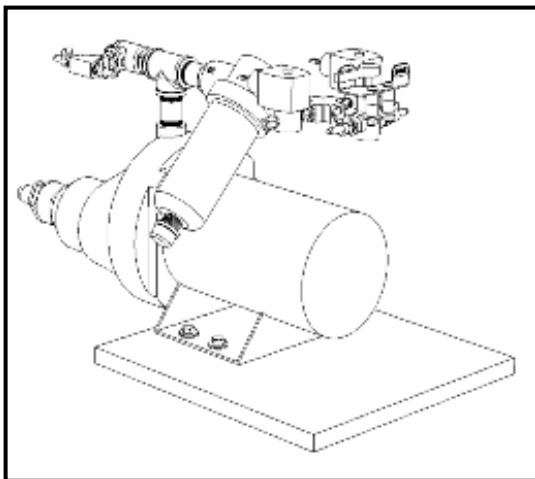

SCORE DISPLAYS - The solid state score displays (AKA Display P.C. Boards) are replaceable as a sub-assembly making service easier.

SIMPLE ELECTRONICS - The new design uses 3-4 electronic boards (AKA the Main P.C. Boards,) making troubleshooting far easier than ever.

NEW TARGET SENSORS - The game utilizes fully encapsulated magnetic switches for the target sensing, greatly extending the reliability of the game.

GAME PLAY

(IN AUTOMATIC MODE)

The object of the game is to shoot water from the gun into a target "pan" making the display indicator rise to the top of the game to win.

The game can be played by 2 to 8 players. The game is designed to be played in a traditional player versus player RACE with 2 players needed to start the game.

When the game is idle, it will normally say SWIPE CARD or INSERT COIN on each display. Unless it is playing the attract mode.

When a player puts enough money into the game to start, the display on his/her side will say "GET READY" and the other side will still say SWIPE CARD or INSERT COIN. Under the side with get ready, a count down from 9-0 will be visible.

Once both players have inserted enough money to play, the count down will continue and the game will start when the timer runs out. If a game is in progress and additional players walk up to play and inserts money, the display at that station will flash "WAIT" until the game in progress has ended. At that time, the previous game play scenario will begin.

In a game, the winning player will win the dispensed PRIZE TICKETS. PRIZE TICKETS are larger 2x4 tickets used for a direct exchange for a prize. They are larger than the conventional redemption game tickets. And the amount of PRIZE TICKETS is dependant on the number of players in each game.

In a 2-4 player game, the game is set to dispense 1 PRIZE TICKET to the winner. The losing players don't receive any tickets.

In a 5-8 player game, the game is set to dispense 2 PRIZE TICKETS to the winner. The losing players don't receive any tickets.

At the end of the game, "WINNER" will flash on the winning station. The beacon light will also rotate when winner is flashing.

1-2. Important Safety Information:

IMPORTANT SAFETY INFORMATION

WARNING: Unplug the game from the AC wall receptacle when servicing this product. Failure to do so could result in serious injury to yourself or others.

Use only a GROUNDED AC receptacle. Failure to do so could result in improper operation or damage to the game and could void your warranty. If you are unsure that your AC receptacle is properly grounded, have a qualified electrician perform this check for you.

Always be sure power to the game is turned off when doing even routine maintenance. Otherwise, moving parts could activate unexpectedly causing injury.

This product is heavy, necessitated by the design. When moving this game, be sure you have adequate help. Use a suitable dolly or hand truck where practical. Use back support when needed.

Depending on the potentially hazardous degrees, the terms of NOTICE, WARNING CAUTION, etc. are used. Be sure to understand the content of the displays before reading the text.

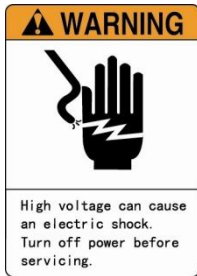

High Voltage Warning:
High voltage can cause an electric shock.
Turn off power before servicing



No Touching Warning:
This part may cause an electric shock or the surface is overheating.
Do not touch this part.

NOTE: ONLY QUALIFIED TECHNICAL PERSONNEL SHOULD WORK ON THIS GAME. FAILING TO COMPLY CAN CAUSE SEVERE INJURY.

1-3. Game Operation:

When starting the game, make sure the power switch has been turned on from the lock cabinet behind unit #6

The Water Blast FEC model operates in 2 different ways:

- 1) Automatic Operation where tickets are exchanged for prizes
- 2) Manual Operation where an operator will start the game and manually hand out the prizes to the winner.

1-3-1. Automatic Operation:

Operational Guideline for Automatic Operation (TICKET REDEMPTION)

NOTE: BE SURE SELECTOR KEY IS SET TO AUTOMATIC OPERATION OR (ON). THIS IS WITH THE KEY STRAIGHT UP AND MEANS THERE IS GOING TO BE NO OPERATOR PRESENT, WHICH REQUIRES 2 PLAYERS TO RACE. (SEE PICTURE TO THE RIGHT)

GAME WILL DISPENSE 2"X4" TICKETS TO THE WINNER

GAME WILL NOT START UNTIL GAME HAS 2 PLAYERS ACTIVATED

AFTER 2 PLAYERS ENTER, THE GAME TIMER WILL START A COUNTDOWN TILL THE START OF THE GAME

THE MORE PLAYERS WHO PLAY THE MORE TICKETS THE PLAYER WINS

2-4 PLAYERS RECEIVE 1 TICKET AND 5-8 PLAYERS RECEIVE 2 TICKETS

PRIZE TICKETS CAN BE REDEMED AT THE REDEMPETION CENTER OR SELECTED LOCATION FOR EXCHANGE OF THE PRIZE WON.

GAME SHOULD HAVE 2 PRIZE LEVELS 1 & 2, THE OVERALL PRIZE VALUE SHOULD EQUAL 25% TO 30% OF THE GAME REVENUE

GAME SHOULD OPERATE IN AUTOMATIC MODE DURING SLOW PERIODS AND BE SWITCHED TO MANUAL MODE DURING PEAK HOURS OF OPERATION



1-3-2. Manual Operation:

Operational Guideline for Manual Operation (WITH OPERATOR AND MANUAL PRIZE HANDOUT)

NOTE: BE SURE SELECTOR KEY IS SET TO MANUAL OPERATION OR (OFF). THIS IS WITH THE KEY FLAT ACROSS AND MEANS THERE 'IS' GOING TO BE AN OPERATOR PRESENT, WHICH REQUIRES 2 PLAYERS TO RACE. WHEN IN THE OPERATOR MODE, IN ORDER TO START A GAME, THE OPERATOR MUST HIT BLACK BUTTON TO START GAME. (SEE PICTURE TO THE RIGHT)



*** GAME OPERATOR BASIC JOB REQUIREMENT ***

MAKE EYE CONTACT AND BE FRIENDLY WITH CUSTOMERS

TALK TO AND INTERACT WITH CUSTOMERS

- Ask are they having fun today
- Ask if they would like to play
- Ask if they know how to play
- Ask if you can explain the game to them

EXAMPLES OF WHAT TO ASK THE POSSIBLE CUSTOMERS TO PLAY THE GAME OR ENTICE:

- "How you doing would you like to play the game?"*
- "Hey Mom if it is just the two of you, one of you has to win!"*
- "Win stuffed animals here"*
- "Check it out, a brand new game, are you ready to have fun?!."*

ENCOURAGE MORE PLAYERS TO JOIN THE GAME

GIVE AWAY PROPER PRIZES TO THE WINNING PLAYER

ENCOURAGE REPLAY AND GAME REPETITION

*** HOW AND WHAT TO DO TO MANUALLY OPERATE THE GAME ***

1. LOCATE OPERATION SELECTOR SWITCH IN GAME
2. INSERT KEY AND SWITCH GAME TO MANUAL OPERATION MODE
 - Game requires 2 players to be able to start the game
 - Start Button beside selector key switch starts the game
 - Red light indicates LOW WATER warning
 - If the red light comes on beside the switch that means that the water level is low. FILL IMMEDIATELY.**

WARNING: DO NOT WAIT FOR THE RED LIGHT TO INDICATE THE WATER LEVEL IS LOW. THE WATER LEVEL SHOULD BE VISUALLY CHECKED DAILY.

3. ABOVE THE OPERATOR WALKWAY IS THE STOCK BIN LOCATION
 - Unlock the grid doors
 - Lift the grid doors up and over until they lay on top of bin
 - Doors can also be swung up and hooked together to remain open
 - Bins need to have enough merchandise to operate before starting
 - Bins also need to be sorted so proper sizes and type can be located

4. WHEN OPERATING GAME DIFFERENT PRIZE LEVELS ARE USED
 - 2-4 players receive a level 1 prize
 - 5-8 players receive a level 2 prize
 - A player can trade 2 level 1 prizes for a level 2 prize
 - Other prize structures can be used but above is a basic operation
5. SWITCHING FROM MANUAL TO AUTOMATIC OPERATION
 - Reverse #2 and #3 procedures above

*** DAILY OPERATIONAL CHECKLIST ***

1. ENSURE GAME BINS ARE FULL OF MERCHANDISE (Stock needs to be replenished every day in the stock chute when an operator is working in the game. When an operator is in the game unlock the stock chute and have it open and ready for the operator to hand the winner the prize. The chute will flip all the way over to a 180 degree angle.)
2. TURN ON GAME POWER SWITCH
3. CHECK LOWER WATER LIGHT AND PHYSICALLY CHECK WATER LEVEL IN WATER TANK
4. CHECK TICKET LEVELS IN TICKET DISPENSERS BEFORE OPENING EACH DAY
5. CLEAN, WIPE DOWN, AND DRY OFF GAME NIGHTLY OR AS NEEDED
6. CHECK ALL LIGHT BULBS FOR WORKING ORDER (THIS INCLUDES TARGET PAN LIGHTS)
7. TURN OFF GAME POWER AND UNPLUG THE RUNNING LIGHTS

NOTE: STOCK AVERAGES WILL RUN SLIGHTLY HIGHER WHEN YOU ARE RACING JUST TWO PLAYERS BUT WILL CATCH EVERYTHING UP LATER IN THE DAY WHEN MORE PLAYERS RACE.

*** MERCHANDISING RECOMMENDATIONS ***

The Water Blast FEC is not designed to be a typical redemption game that gives tickets to redeem in a normal redemption center. The game is designed to be a mass merchandiser for the FEC. BSR has long recognized the fact that when players win and display their prizes won that it fuels the desire of other players to get a prize of their own. With that age-old lesson the game is designed to distribute merchandise directly and quickly to the players. The more quantity of merchandise distributed the more the player will look for where the prizes are coming from and the more the desire to win their own becomes.



OVERHEAD STOCK BIN PICTURED

The idea of the Water Blast FEC is to send as many customers home with a prize as possible in the short window of opportunity. This is something that a traditional redemption machine cannot do consistently. The Water Blast FEC brings the true Midway game to your FEC to be able to operate in both slow and busy times with the ability to mass merchandise.

It is also recommended that the merchandise used in this game is different than what is used in the redemption center, and uses an item that is unique to the Water Blast FEC. This will also avoid the game affecting revenue from the redemption games. The Water Blast FEC is designed to produce incremental revenue and not just take revenue from the other games.

2. PROGRAMMING

2-1. ENTERING PROGRAMMING MODE:

The programming options are readable only by the game operator for the purpose of customizing the game to suit their location.

The operator will press the "PROGRAMMING" button once to enter the programming mode.

The operator will press the "SELECT" button to scroll through the various options that are on the left-hand display.

The operator will press the "STEP" button to scroll through the various settings for each option that are shown on the right-hand display.

The operator will press the "PROGRAMMING" button once again to EXIT the programming mode and save all of the new values to the games memory.

Below is detailed information for the operation of each of the programming options.

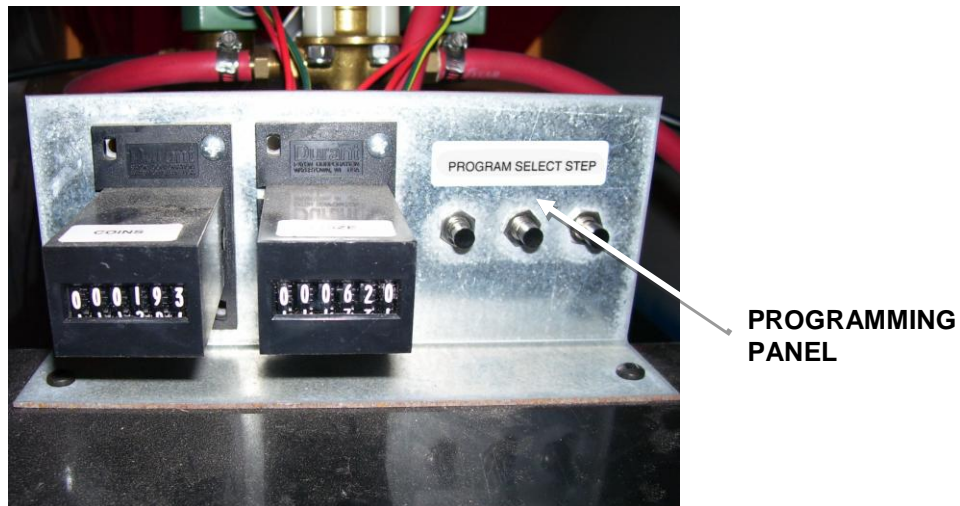

2-2. VOLUME:

This option controls the sound volume for the speaker. The range for this option is **1-6** (6 being the loudest). The default value for this option is 3.

2-3. COINS PER CREDIT (COIN/CR):

This option determines how many coins are needed to earn a credit. Each credit will automatically start a game. The range for this option is **1-10**; the default value for this option is 1.

NOTE: There is no "free play" option for this game. If free play is desired, set the game to 1 coin per credit and install a momentary contact push button to start the game.

2-4. ATTRACT MODE (ATTRACT TIME):

This option determines how often the attract sounds or (player taunting) will be heard from the game. The range for this option is **0-5** (minutes). Setting a **0** shuts the attract mode off. The default value for this option is 3.

2-5. JUST FOR PLAYING TICKETS:

This option determines how many tickets the player gets just for playing the game. The only option for this is "0".

2-6. WINNER TICKETS:

This option determines how many tickets the player gets for winning the game. This is a preset option and the only option is "1". For 2-4 player

2-7. GAME TIME TO WIN:

This option determines how many seconds it takes to win the game when the target is kept depressed. The range for this option is 5-20 seconds. The default value for this option is "12".

2-8. TIME OUT:

This option determines how many seconds of inactivity (target not depressed) are necessary for the game to automatically end. The range for this option is 30, 40, 50, 60, 70, 80 or 90 seconds. The default value for this option is "30". NOTE: If the game auto ends, no tickets will be dispensed and there are no "winners".

2-9. DRAIN WATER:

This option is used as a convenient way to run the pump when setting up, changing water, or draining the game. Pressing the VALUE button will turn the pump on or off. The options are 00 or 01. 00 being off and 01 being on.

2-10. LINK ID:

This option is based on how many boards are being used in the game. The value determines which players are assigned to each board. (*Ex. Board 1 would control players 1 and 2. Board 2 would control players 3 and 4. Board 3 would control players 5 and 6. And so on...*)

The range for this option is 0-4 since there can be up to 4 boards allowing for 8 players. "1" is the factory default value.

2-11. MONEY:

This option determines whether the board is set up for Coin Play or for a Card Swipe. The options for this setting are 0 or 1. 0 sets the game up for Coin Play, while 1 sets the game up for a Card Swipe. "1" is the factory default for the Money option.

2-12. RESET: (*Default programming value - reset*)

This option will reset the game to factory default values. The range for this option is 0-1. Setting a "1" will reset the values to factory default. The default value for this option is "0".

2-13. PROGRAMMING OPTIONS:

STANDARD ARCADE OPTIONS				
REGISTER	MIN/MAX	BSR	ACTUAL	DESCRIPTION
Volume	1-6	3	_____	Volume Control
Coins/Credit	1-10	1	_____	Number of Coins per Game
Attract Mode	1-5	3	_____	Minutes Between Bally Music
Default Tickets	0	0	_____	Tickets Just for Playing
Winner Tickets	1	1	_____	Winning Tickets Per game
Time to Win	5-20	12	_____	Time to Win in Seconds
Time Out	30, 40, 50, 60, 70, 80, 90	30	_____	Time of Inactivity/Auto Win
Drain Water	0-1	On/Off	_____	Pump ON/OFF (Manual)
Link ID	1-4	1	_____	Controls which board number
Money	0-1	0	_____	Coin Play or Coin Swipe
Reset Defaults	0-1	0	_____	Reset Factory Default Settings

2-14. REPROGRAM LINKING GAMES (ALSO COVERS HOW TO RESET SETTINGS):

(RESETTING THE BOARDS)

1. Unplug all the networking cables running from each board to another. (They are the cables that resemble phone cables)
2. Go to the main control board (the board for players 1 and 2). Enter the programming mode by pressing the PROGRAMMING button. (The first black button on programming panel to the left)

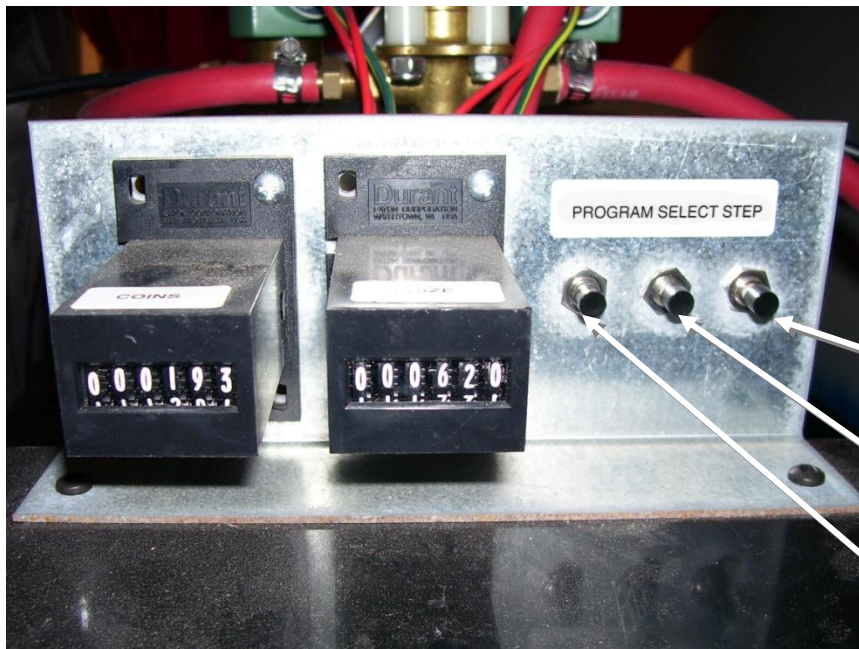

PROGRAMMING PANEL

STEP Button

SELECT Button

PROGRAMMING Button

3. After entering the programming mode, press the SELECT button (The center black button on the programming panel) until the first two front displays read "Reset Defaults".
4. Once the first two front displays read "Reset Defaults" press the STEP button until the corresponding displays read a 1 at the bottom.
5. To lock in the change to the settings press the SELECT button and then to exit the programming mode press the PROGRAM button.

6. Proceed to the next control board and follow the exact steps for that board starting at step #2 above, and proceed through to step #5. (Continue in this fashion for the remainder of the boards.)

(REPROGRAMMING THE BOARDS)

7. Once all stations have been reset, reconnect all of the phone cables to each board. The cables must be plugged into P11 or P12 phone jacks.

P11 & P12 PHONE JACKS

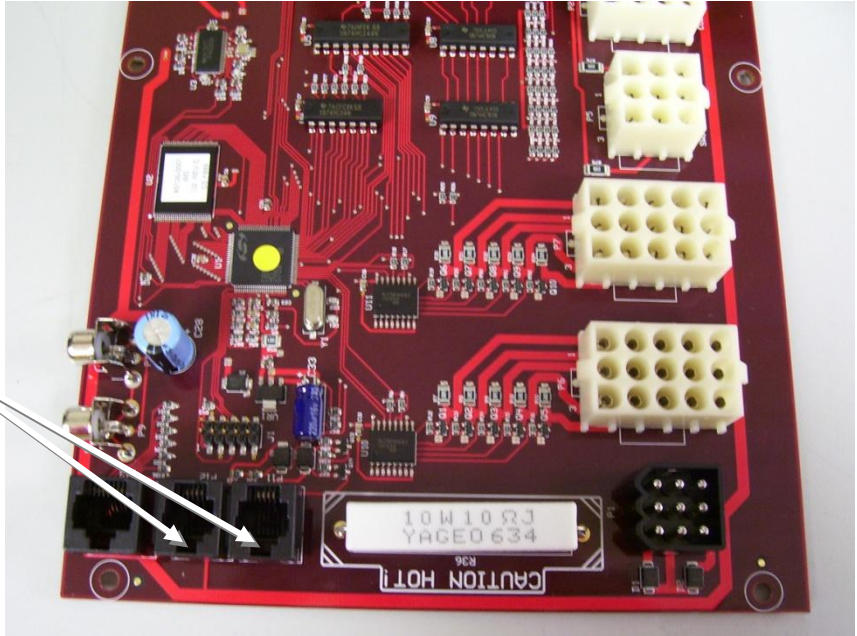

8. Once all the phone cables are plugged back into the proper jacks go back to the board one, which is the main control board (the board for players 1 and 2) and enter the programming mode once again by pressing the PROGRAMMING button on the programming panel. And press the SELECT button (The center button on the programming panel) until the corresponding displays read "Link ID".
9. Once "Link ID" is visible on the corresponding displays (If networked properly) the corresponding display should read a "1" to express that the board has been set to "board 1"
10. Proceed to the next boards control panel, make sure the corresponding displays still read "Link ID" and press the STEP button to set that specific board to show a 2 for board 2. (Do this for the following boards setting the "Link ID" to 3 for board 3 etc. etc. for however many boards your game has, up to 4 boards)
11. Go back to the main control board (the board for players 1 and 2) and press the PROGRAMMING button to get out of the programming mode.
12. Once the game links up and you see the displays go through a brief track mode (the game will light up several ways) you should see the displays list the unit #s 1-8 (for a 8 player game) at the bottom.

NOTE: TO RESET DEFAULTS FOLLOW INSTRUCTIONS STARTING AT #3, GOING INTO THE PROGRAMMING MODE AND PRESS THE SELECT UNTIL THE FIRST TWO FRONT DISPLAYS READ "RESET DEFAULTS" THEN PRESS THE "STEP" BUTTON.

3. MAINTENANCE AND TROUBLESHOOTING

3-1. Quick Troubleshooting:



WARNING

For your safety and to reduce risk of damage to your game read the Important Safety Information in Chapter 1-2 before attempting any troubleshooting procedure.

TROUBLESHOOTING PHILOSOPHY

When troubleshooting any product, certain general guidelines should be followed.

1. Always check to be sure that your game is turned on. Be sure that all of the fuses in the game are functional and check to see that the AC voltage is in the proper operating range for your game.
2. Check to be sure that all of the game harnessing is plugged in properly and that all of the pins are firmly seated in the connectors. It is always possible that a harness can be damaged by rough shipping or moving.
3. Check game harnessing to be sure that none of the wires have become damaged. Using a handheld multi-meter, check continuity of the wires to make sure they are not broken.
4. Check for obvious damage to any P.C. Boards or electrical components.
5. If you have multiple games or multiple parts on a game, change or exchange the parts and see if the problem goes away or moves to another location. This way you can quickly eliminate certain parts as being the problem with the game.
6. When changing electronic or electrical components, ALWAYS turn off and unplug the game.
7. Check to see that all power supplies are delivering the specified voltages to the P.C. Boards and components as shown in the manual.

For detailed servicing and repair information see the full the full repair section of this manual.

Symptom	Possible Problem	Solution
	Power	Power
Sound Problems -No sound -Low Sound -Intermittent Sound	Low Volume Faulty speaker harnessing Faulty speaker Faulty sound board or sound board harnessing Faulty Main P.C. Board	Check Volume Control and adjust as necessary Check connections and/or repair harnessing Check and/or replace speaker Check connections or Replace Sound Board Check and/or repair or replace Main P.C. Board
Game does not take or add money correctly	Card Swipe dirty or improperly adjusted Faulty Card Swipe Faulty Card Swipe harness or connector Improperly programmed electronic mech Game improperly programmed Faulty Main P.C. Board or component	Clean and adjust Card Swipe as necessary Check and/or replace Card Swipe Check and/or repair Card Swipe harnessing Reprogram or replace electronic mech Check programming options and adjust Repair and/or replace Main P.C. board
Ticket Dispenser not working properly, or no tickets being dispensed	No tickets in the game Tickets jammed in dispenser Ticket dispenser sensor blocked with debris Poor connection on the ticket dispenser Game improperly programmed Faulty ticket dispenser Faulty ticket dispenser harnessing Faulty Main P.C. Board	Refill ticket dispenser and press the reset button Clear ticket jam Clean off sensor Check and/or replace connectors Check ticket programming options Replace dispenser Check and/or repair harnessing Replace or repair Main P.C. Board
Game will not start or pump will not run	Game power off Main fuse blown Faulty solid state relay Faulty pump Power Supply problem or failure Faulty P.C. board or component	Check on/off switch and power cord Check and/or replace fuse as necessary Check and replace solid state relay Check and replace pump Check Power Supply output and connections Repair and/or replace main P.C. board
Game stops or is stopped with nothing displayed	The power connector is disconnected. Possible faulty connection or short circuit.	Reconnect the connector securely. Check all circuitry for faulty connections or short circuits.
Water stream crooked or weak	Clogged gun tip Partially clogged filter Kinked hose Low water level or no water	Check and clean gun tip Check filter and clean if necessary Check all hoses Check water level and fill if necessary
Display lights won't move	Faulty target switch Faulty or disconnected harness Faulty Main P.C. board	Check target switch Check and repair harnessing Repair or replace main P.C. board
Water not coming out of gun	Clogged gun tip Kinked hose Low water level or no water Faulty solenoid valve GFI circuit tripped Faulty Pump Faulty Main P.C. board	Clean tip with paper clip Check hoses for kinks Check water level and fill if necessary Check or replace solenoid valve Start game and push GFI reset button Repair or replace pump Repair or replace Main P.C. Board
Programming button and counters	Disconnected programming Panel harness	Check connector Check connector

3-2. Detailed Troubleshooting and Repair:

3-2-1. Glass Cleaning:

1. Clean the inside of the glass with a plastic scrub pad to remove dirt and sediment from the glass. DO NOT use any steel wool or scotch bright pads as these will damage the plastic side glass panels.

NOTE: IF THE GLASS IS BADLY STAINED, USE C.L.R. MINERAL REMOVAL. SPRAY FIRST TO GET RID OF TOUGH MINERAL DESPOSITS.

2. Spray RAIN-X on the inside of the glass to help prevent minerals from forming on the glass.

3. Clean the outside of the glass with any good commercial glass cleaner.

3-2-2. Cleaning Gun Parts:

It is possible after extended periods of time, or if the water you use is very high in mineral content, that you may have to clean deposits or debris from the gun assembly.

1. To clean the gun tip, try cleaning with a paper clip first. If that doesn't work, unscrew the tip to clean. (See image to the right)

2. For larger debris, unscrew the gun assembly from the top of the control panel. Disconnect the spring from underneath. (See image below)

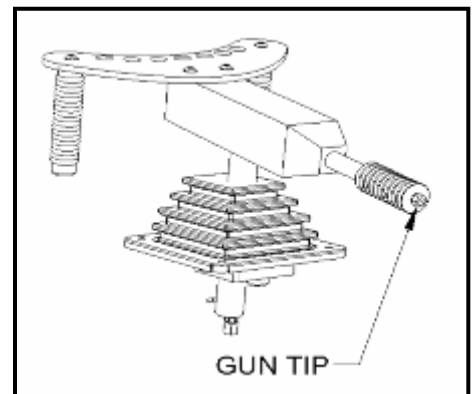
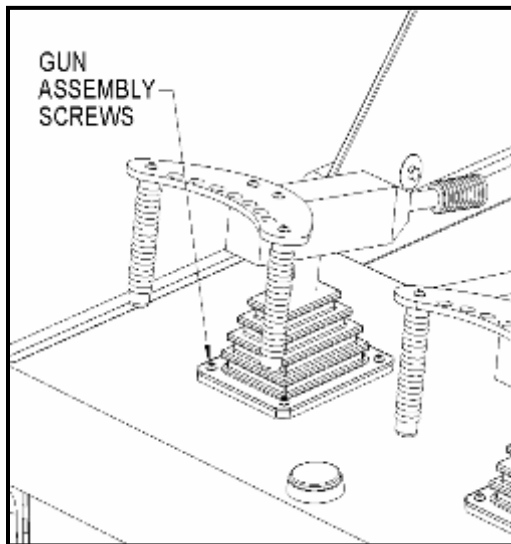

3. Remove the hose and nozzle tip from the gun.

4. Run a coat hanger or thick wire through the gun passages to remove any blockage.

5. With the tip off the gun, re-install the gun and connect the hose.

6. Play a few games to allow any debris to escape the gun body.

7. Re-install the gun tip and check for proper operation.

3-2-3. Target Sensors:

1. Unscrew the target pan from the game.

2. Unscrew the magnetic sensor from the tank back.

3. Unplug the sensor.

4. Re-install the new sensor using the other sensor as a guide to proper positioning. (See image to the right)

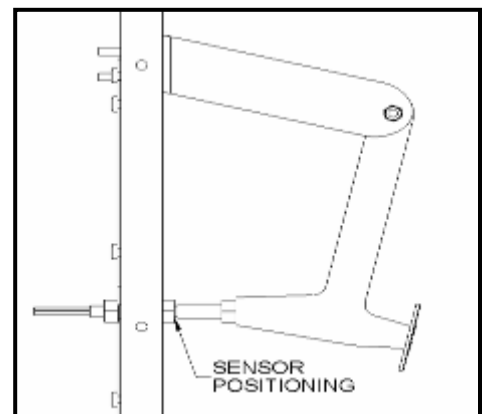

5. Check for proper alignment between the magnetic sensor and the magnet that is located on the target arm.
6. Re-install the target pan.
7. Play a couple of games to check for proper operation.

3-2-4. Display P.C. Board Removal and Installation:

WARNING: BE SURE TO UNPLUG THE GAME BEFORE SERVICING TO AVOID SERIOUS INJURY OR DAMAGE TO THE GAME.

1. Unplug selected display from Main P.C. Board
2. Remove the 4 screws on the mounting bezel at the top and bottom of the display.
3. Tilt the display back and slide the harness out from the counter.
4. Assemble in reverse order.

3-2-5. Display P.C. Board Servicing

1. Slide the display filter (Plexiglass cover) out of the housing.
2. Remove the 8 bolts that hold the Display mounting bracket to the Display housing.
(See image to the right)
3. Slide the mounting bracket out of the housing.
4. Remove the connectors and defective display P.C. Board.
5. Assemble in reverse order.

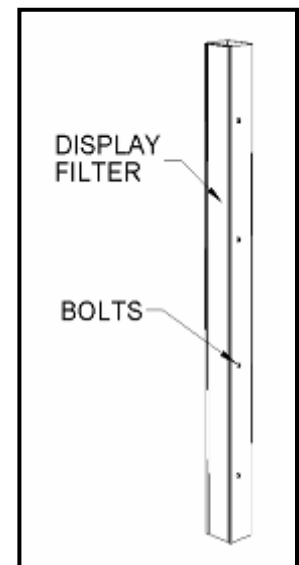

4. PARTS LISTING

MECHANICAL PARTS		ELECTRONIC / ELECTRICAL PARTS	
ARWB1017	GUN BODY	ARWB2001-LINK (FEC)	MAIN P.C. BOARD
ARWB1018	GUN HANDLE MOUNT	ARWB2002	MAGNETIC TARGET SENSOR
ARWB1019	WATER GUN HANDLE	ARWB2003	TARGET MAGNET
ARWB1020	GUN MOUNTING PLATE	ARWB2004	MARQUEE LIGHT FLASHER UNIT
ARWB1021	GUN BOOT BEZEL (STAINLESS)	ARWB6001	1/2 HP PUMP ONLY
ARWB1025	TARGET MOUNTING BRACKET	E0025100	12 VOLT COUNTER
ARWB3001	WATER GUN SWIVEL BLOCK	E0028300	TURBO BULB (FLASHING LIGHTS)
ARWB3016	TARGET PIVOT SWING	E0030630	BEACON LIGHT BASE
ARWB3017	TARGET DISK	E0030632	BEACON LIGHT CHROME RING
ARWB6002	PRESSURE GAUGE	E0030635-RED	BEACON LIGHT RED DOME
CX800085	DISPLAY FILTER (SMOKED GREY)	E0070012-CLR	LENS BODY (FLASHING LIGHTS)
M0006905	GUN CENTERING SPRING	E0070015-CL	CLEAR LENS CAP
MX006103	GUN BARREL TIP	E0070016-BL	BLUE LENS CAP DOT
MX006330	GUN BARREL	E0070016-RED	RED LENS CAP DOT
MX007203	PAINTED TARGET PAN ASSEMBLY	E0070016-YE	YELLOW LENS CAP DOT
GRAPHICS / DECALS		E0800044	BULB RETAINING CLIP
	SERVICE MANUAL	E0800070	6" X 9" SPEAKER
ARWB7017	LEVER DECAL "DRAIN"	E0800157	DISPLAY P.C. BOARD
ARWB7018	LEVER DECAL "GAME"	E0800201	200 WATT POWER SUPPLY

		E0800310 E0023880	SOLID STATE RELAY FUSE, 15 AMPS SLO-BLO
--	--	----------------------	--

Main P.C. Board (Linkable)
Part# ARWB2001-LINK

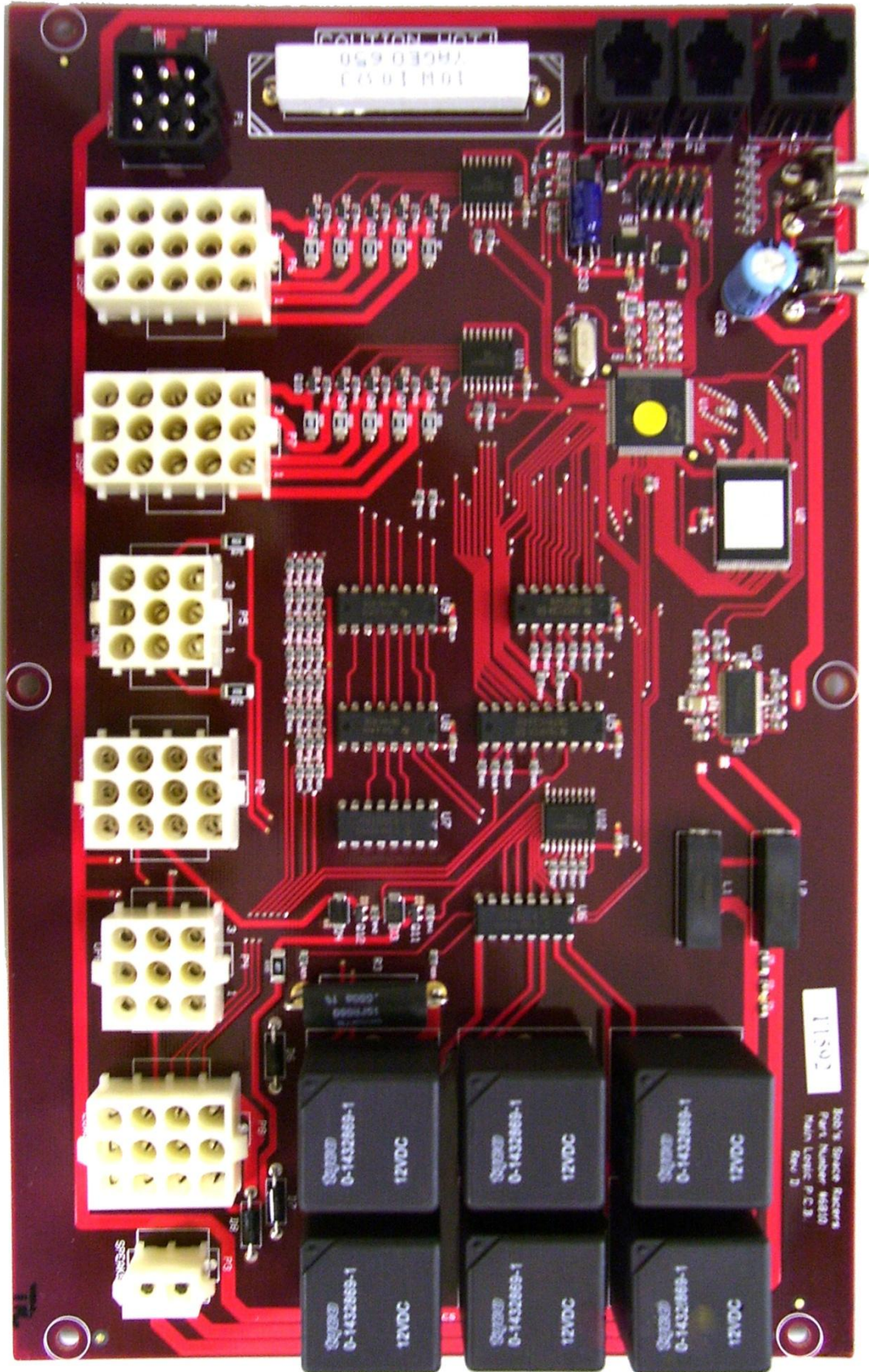

5. SCHEMATICS

Water Blast Wiring Harness

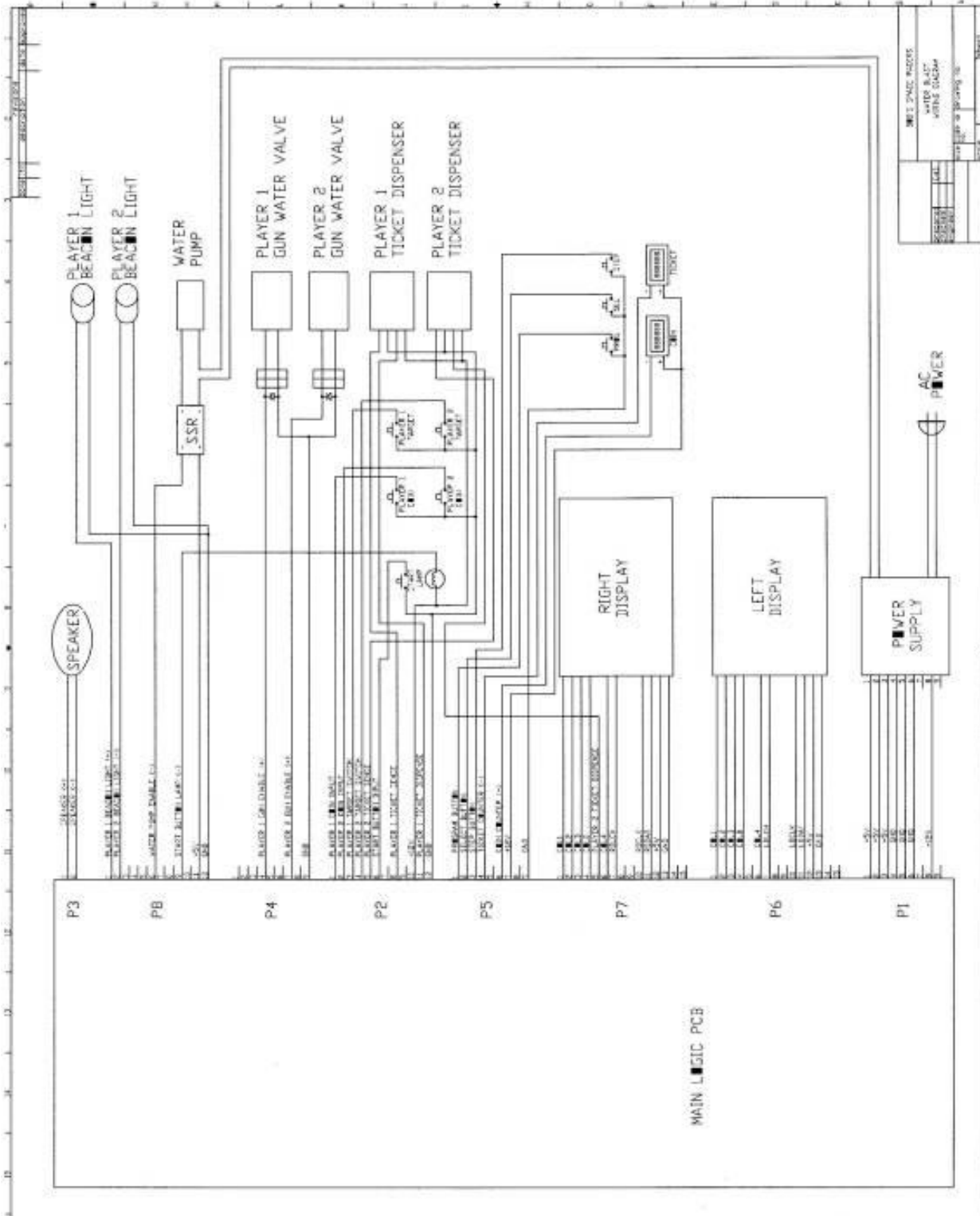

LED Display Schematic

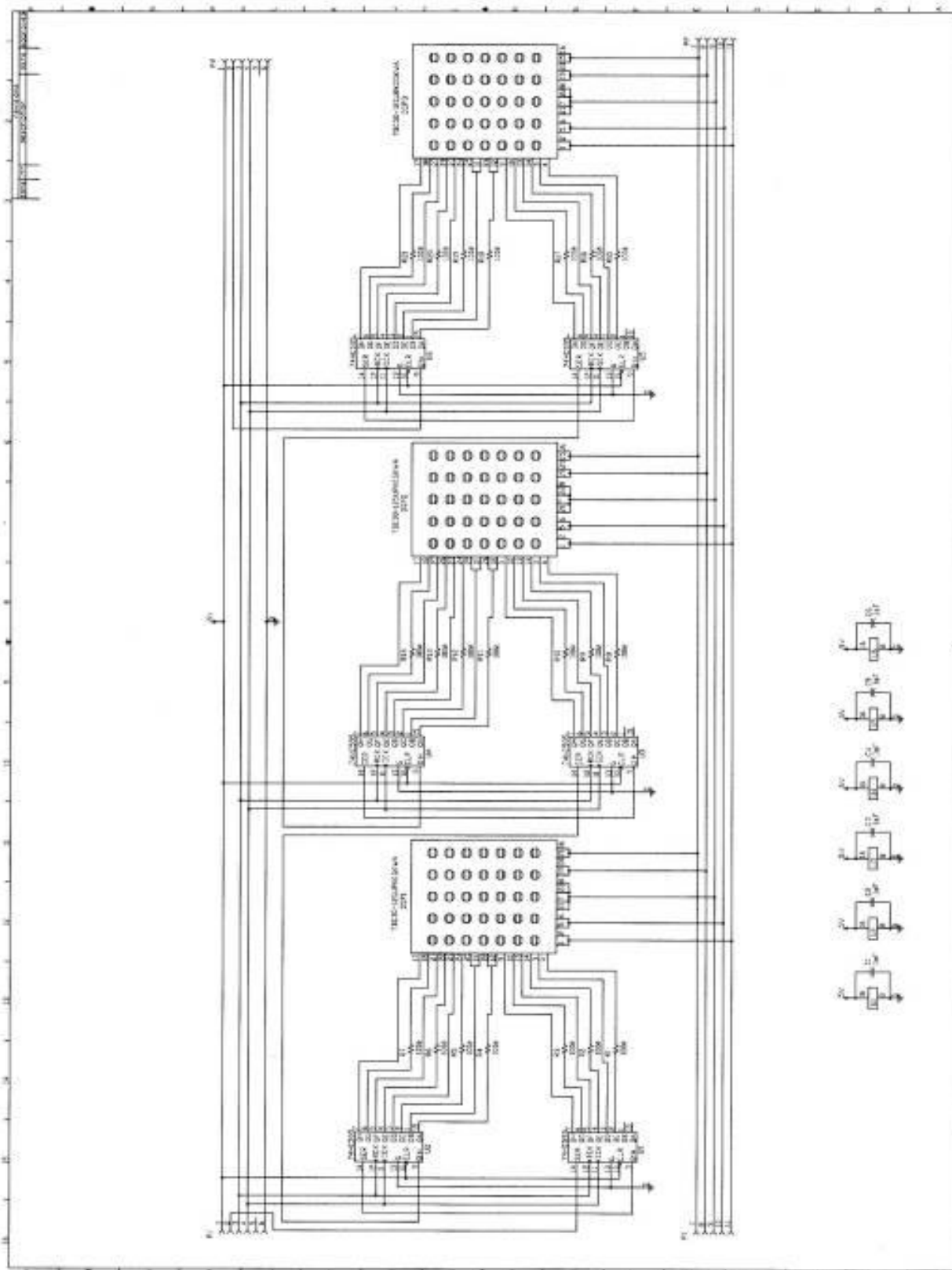

6. WARRANTY

BOB'S SPACE RACERS INC. 90 DAY COIN-OPERATED GAME WARRANTY

1. INCLUDED IN THIS WARRANTY Bob's Space Racers®, Inc. warrants to the original purchaser only that the equipment that is the subject of this sale conforms to its specifications, and is free from defects under normal service for a 90 day period from the original date of delivery. This warranty does not include any damages resulting from occurrences listed in paragraph 2 below. This warranty is not transferable under any circumstance. Any claims under this warranty must be received in writing by Bob's Space Racers®, Inc. within 120 days from date of delivery. Within a reasonable time of such written notification Bob's Space Racers®, Inc. will replace or repair any defective component of the equipment or part thereof which fails for reasons other than normal service, use, or wear. Bob's Space Racers®, Inc. reserves the right to request dated proof of purchase by the end user (original purchaser) at any time. Light bulbs are specifically excluded from this warranty and shall be the sole responsibility of the purchaser. Bob's Space Racers®, Inc., within its sole discretion, makes the final determination as to whether to repair or replace any component and whether any such repair or replacement shall be performed where the equipment is located or at its home facility in Volusia County, Florida, or another facility of its sole choice. Any and all freight charges for the purposes of repair or replacement shall be paid by the original purchaser. All defective parts shall be returned to Bob's Space Racers®, Inc. if requested. Bob's Space Racers®, Inc. does not warrant that the equipment will meet any original purchaser's specific requirements or that the operation of the equipment will be uninterrupted. These remedies are the original purchaser's exclusive remedies for breach of warranty.
2. EXCLUDED BY THIS WARRANTY Bob's Space Racers®, Inc. does not warrant (a) any product, components or parts not manufactured by Bob's Space Racers®, Inc.; (b) damages caused by use of the equipment for purposes other than those for which it was designed; (c) defects caused by failure to provide a suitable installation environment for the equipment; (d) damage caused by unauthorized attachments, modification, or service; (e) damage caused by normal wear and tear or improper power supply; (f) damage caused by accident or disaster such as fires, flood, lightning, and wind; or (g) any other abuse or misuse of the equipment.
3. EXCLUSIVE WARRANTY. THE FORGOING WARRANTY IS EXCLUSIVE AND IN LIEU OF ALL OTHER WARRANTIES OR REMEDIES, WHETHER WRITTEN, ORAL OR IMPLIED. THERE ARE NO WARRANTIES WHICH EXTEND BEYOND THE DESCRIPTION ON THE FACE HEREOF. ANY AND ALL IMPLIED WARRANTIES OF MERCHANTABILITY, FITNESS FOR A PARTICULAR PURPOSE, COURSE OF DEALING OR USAGE OF TRADE ARE HEREBY EXPRESSLY DISCLAIMED AND EXCLUDED.
4. REMEDIES LIMITED. UNDER NO CIRCUMSTANCES, EXCEPT TO THE EXTENT PROHIBITED BY APPLICABLE LAW, SHALL BOB'S SPACE RACERS®, INC. BE LIABLE FOR ANY LOSS OR DAMAGE, DIRECT OR INDIRECT, SPECIAL INCIDENTAL OR CONSEQUENTIAL ARISING OUT OF THE USE OR INABILITY TO USE THIS EQUIPMENT INCLUDING BUT NOT LIMITED TO ANY CLAIM FOR LOSS OR PROFITS, LOSS OF SAVINGS OR REVENUE, LOSS OF USE OF THE EQUIPMENT, OR ANY ASSOCIATED EQUIPMENT, FACILITIES OR SERVICE, DOWNTIME, THE CLAIMS OR COSTS OF THIRD PARTIES INCLUDING CUSTOMERS AND INJURY TO PROPERTY. Some states do not allow limitations on how long an implied warranty lasts or the exclusion or limitation of incidental or consequential damages, so the above limitations or exclusion may not apply to you. This warranty gives you specific legal rights, and you may also have other rights which vary from state to state.
5. NO OTHER WARRANTIES. Unless modified in writing and signed by both parties, this agreement is understood to be the complete and exclusive agreement between the parties, superseding all prior agreements, oral or written, and all other communications between the parties relating to the subject matter of this agreement. No employee or representative of Bob's Space Racers®, Inc. or any other party is authorized to make any other warranty or to assume any other liability in connection with the sale of its equipment.
6. TIME LIMIT FOR CLAIMS. Any claim for breach of warranty or claims under this warranty must be received in writing by Bob's Space Racers®, Inc. within 120 days following delivery of the equipment.
7. FUTURE CHANGES. Bob's Space Racers®, Inc. reserves the right to reserve, change or modify the construction and design of its equipment or any component part or parts thereof without incurring the obligations to make such changes or modifications in present equipment.
8. ALLOCATION OF RISKS. This agreement allocates the risks of equipment failure between Bob's Space Racers®, Inc. and the original purchaser. This allocation is recognized by both parties and is reflected in the price of the goods. THE PURCHASER ACKNOWLEDGES THAT IT HAS READ THIS AGREEMENT, UNDERSTANDS IT, AND IS BOUND BY ITS TERMS.
9. TO OBTAIN WARRANTY SERVICE. The original purchaser must, at his/her own expense, bring or ship the equipment to an authorized location for service. Additionally, the original purchaser must pay all freight, shipping or transportation charges for the return of the equipment from Bob's Space Racers®, Inc. to the original purchaser. Telephone or write:

Bob's Space Racers®, Inc.
427 15th Street
Daytona Beach, FL 32117
Telephone number: 386/677-0761
FAX: 386/677-0794

WHEN CALLING FOR SERVICE

1. When calling for service, please check the service manual first. Many times the answer to your problem has been addressed in this documentation.
2. Please make sure you have the serial number of the game ready when you call.
3. If this is a repeat call, please tell the service technician that you have made a previous call regarding this problem. This way we will be able to retrieve the history on your game allowing us to serve you better and save you time.
4. Please retain proof of purchase for your product. This might be requested for warranty repairs.
5. Please call from the game if possible since we might need you to check certain things on the game while we are on the telephone with you.

IF YOU HAVE ANY QUESTIONS OR COMMENTS, PLEASE CALL OUR SERVICE DEPARTMENT AT

(386) 677-0761

(MONDAY – FRIDAY, 8:30AM – 5:00PM EST, EXCLUDING HOLIDAYS)

(or)

EMAIL QUESTIONS TO: Tech@BobsSpaceRacers.com

(or)

**VISIT THE “CUSTOMER SUPPORT” SECTION ON OUR WEBSITE:
WWW.BOBSSPACERACERS.COM**

WATER BLAST LINKABLE OPERATION MANUAL



1-4 Games Linkable
2-8 Player Positions

! WARNING

Be sure to read this Operation Manual before using your machine to ensure safe operation.

©2008 Bob's Space Racers Incorporated

427 15th STREET • DAYTONA BEACH • FLORIDA • 32117

PHONE **386-677-0761** FAX **386-677-0794**

BOBSSPACERACERS.COM

SEPTEMBER 2008

©2008 BOB'S SPACE RACERS INC.

WATER BLAST™ (LINKABLE)



TABLE OF CONTENTS

1. INTRODUCTION

- 1-1. Overview and Technical Features:
- 1-2. Important Safety Information:

2. PROGRAMMING

- 2-1. Entering Programming Mode:
- 2-2. Volume:
- 2-3. Coins per Credit:
- 2-4. Attract Mode:
- 2-5. Just for Playing Tickets:
- 2-6. Winner Tickets:
- 2-7. Game Time to Win:
- 2-8. Time Out:
- 2-9. Drain Water:
- 2-10. Reset Defaults:
- 2-11. Programming Options:
- 2-12. Reprogram Linking Games (Also covers how to reset settings):

3. MAINTENANCE AND TROUBLESHOOTING

- 3-1. Quick Troubleshooting:
- 3-2. Maintenance:
- 3-3. Detailed Troubleshooting and Repair:
 - 3-3-1. Changing the Water:
 - 3-3-2. Glass Cleaning:
 - 3-3-3. Draining the Water Tank:
 - 3-3-4. Filling the Water Tank:
 - 3-3-5. Water Pump Removal:
 - 3-3-6. Water Pump Installation:
 - 3-3-7. Cleaning Gun Parts:
 - 3-3-8. Target Sensors:
 - 3-3-9. Main P.C. Board Removal and Installation:
 - 3-3-10. Display P.C. Board Removal and Installation:
 - 3-3-11. Display P.C. Board Servicing:

4. PARTS LISTINGS

5. SCHEMATICS

6. WARRANTY

1. INTRODUCTION

1-1. Overview and Technical Features:

Thank you for purchasing the new WATER BLAST™ from Bob's Space Racers®. Built on a long tradition of value, the WATER BLAST™ retains all of the great game play you have come to expect from a game from BSR. It has been designed and engineered by taking years of experience in producing industry leading Water games and combining this experience with modern manufacturing technology developed for this application. All of this is brought together to provide the operator and customer with the best possible experience.

FEATURES

FOLDING DESIGN - The new cabinet folds up for easy and fast assembly. The game can be assembled and ready to play in as little as 15 minutes.

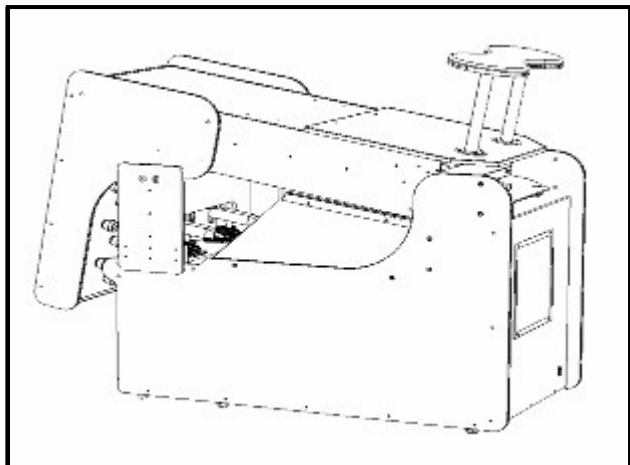

WATER SHIELD - The new water shield has a tempered glass top and scratch resistant acrylic sides for years of service. This design can be washed over and over and still retain its like new appearance.

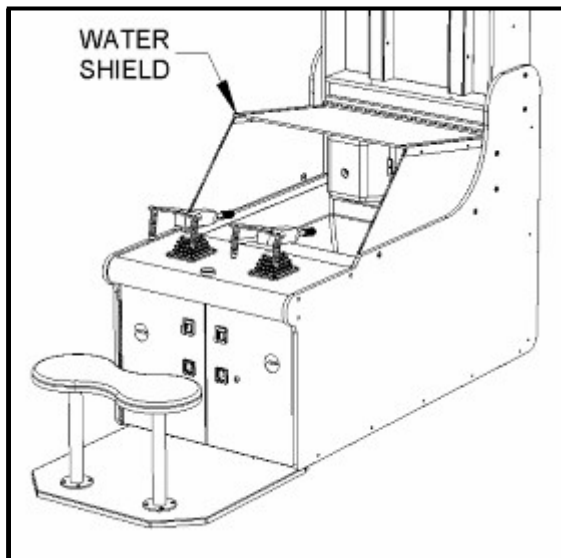

WATER TANK - The new water tank is made from vacuum formed molded plastic with smoothly rounded corners. This tank will look great for years to come and is very easy to clean.

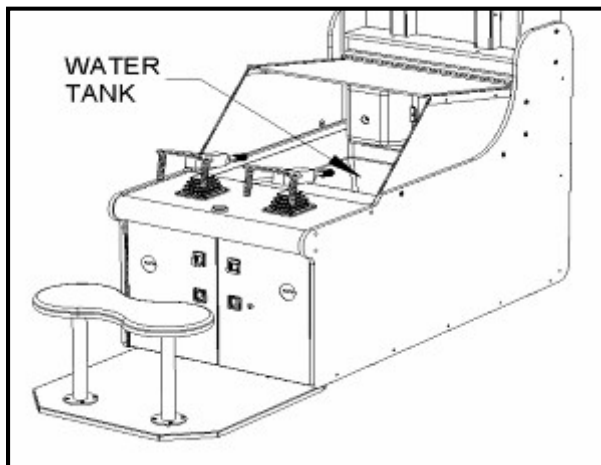

UP FRONT ACCESS - All servicing of the game can be done through the front doors. This eliminates having to move the game away from the wall for access to the pump and electronic components. For example, removing 1 bolt from the cash box enclosure makes it possible to slide the pump unit right out through the front door

WATER PUMP ASSEMBLY - The water pump assembly uses an all plastic impeller and housing to completely eliminate any rusting or corrosion in the water system. This greatly extends the time between water changes. The pump assembly also uses a basket type washable water filter in a clear-view housing to keep the game working properly. The entire pump assembly can be easily removed from the game making bench top servicing possible. *(Picture on next page)*

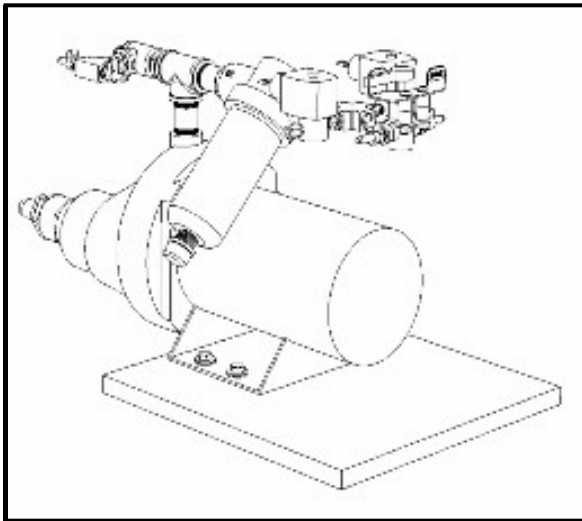

SCORE DISPLAYS - The solid state score displays (AKA Display P.C. Boards) are replaceable as a sub-assembly making service easier.

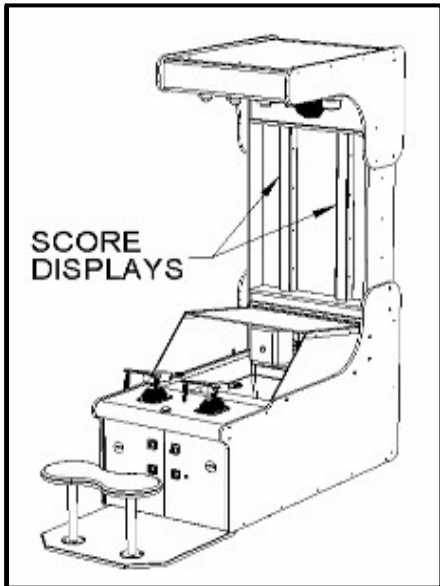

SIMPLE ELECTRONICS - The new design uses only 1 electronic board (AKA the Main P.C. Board) making troubleshooting far easier than ever.

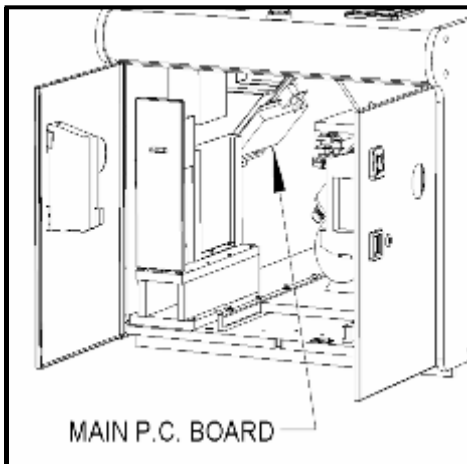

NEW LIGHTING - The game uses florescent lighting throughout greatly extending the time between bulb changes to years rather than months.

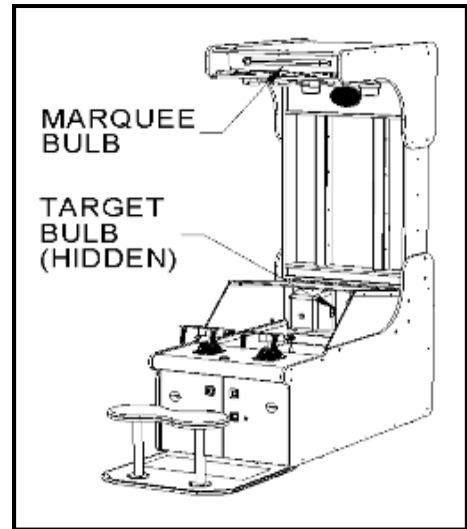

NEW SCORE (TARGET) SENSORS - The game utilizes fully encapsulated magnetic switches for the score (target) sensing, greatly extending the reliability of the game.

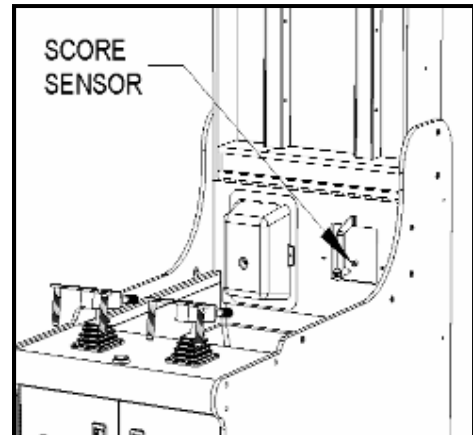

GAME PLAY

The object of the game is to shoot water from the gun into a target "pan" making the display indicator rise to the top of the game to win.

The game can be played by 1 or 8 players. The game is designed to be played in a traditional player versus player RACE or as a SINGLE player game if there is no one available to compete with.

When the game is idle, it will normally say INSERT COIN(S) on each display. Unless it is playing the attract mode.

When a player puts enough money into the game to start, the display on his side will say "GET READY" and the other side will still say INSERT COIN(S). Under the side with get ready, a count down from 9-0 will be visible.

Once both players have inserted enough money to play, the count down will continue and the game will start when the timer runs out OR as soon as the start button is pushed. If one player has started a game and a second player walks up to play and inserts money, the display on his side will flash "WAIT" until the game in progress has ended. At that time, the previous game play scenario will begin.

In a 2 or more player RACE game, the winning player will win BOTH the WINNING share of tickets and the JUST FOR PLAYING tickets, while the loser will win only the JUST FOR PLAYING tickets.

For example:

The game is set for 3 tickets JUST FOR PLAYING and 5 tickets for WINNING.

In a single player game, the player wins 8 tickets period once he or she wins.

In a 2 player game, the winner would get the 8 tickets PLUS the 5 win tickets from the loser for a total of 13 tickets. The loser would get the 3 tickets just for playing. The winnings increase like this depending on the number of additional players. Winning 5 "win" tickets for each player competing.

At the end of the game, "WINNER" will flash on the winning side OR when ever the player gets to the top on the single player game type. The beacon light will also rotate when winner is flashing.

1-2. Important Safety Information:

IMPORTANT SAFETY INFORMATION

WARNING: Unplug the game from the AC wall receptacle when servicing this product. Failure to do so could result in serious injury to yourself or others.

Use only a GROUNDED AC receptacle. Failure to do so could result in improper operation or damage to the game and could void your warranty. If you are unsure that your AC receptacle is properly grounded, have a qualified electrician perform this check for you.

Always be sure power to the game is turned off when doing even routine maintenance. Otherwise, moving parts could activate unexpectedly causing injury.

This product is heavy, necessitated by the design. When moving this game, be sure you have adequate help. Use a suitable dolly or hand truck where practical. Use back support when needed.

Depending on the potentially hazardous degrees, the terms of NOTICE, WARNING CAUTION, etc. are used. Be sure to understand the content of the displays before reading the text.

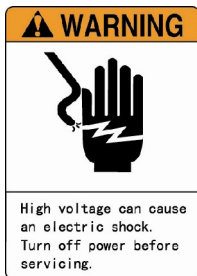

High Voltage Warning:

High voltage can cause an electric shock.
Turn off power before servicing



No Touching Warning:

This part may cause an electric shock or the surface is overheating.
Do not touch this part.

NOTE: ONLY QUALIFIED TECHNICAL PERSONNEL SHOULD WORK ON THIS GAME. FAILING TO COMPLY CAN CAUSE SEVERE INJURY.

SET UP

1. Clear out a location to place the game.
2. Remove all packaging from the game.
3. Remove the seat base from the top of the game by removing the 2 bolts holding it to the back door.

NOTE: DO NOT DISCARD THE BOLTS; YOU WILL NEED THEM TO ATTACH THE SEAT BASE TO THE GAME.

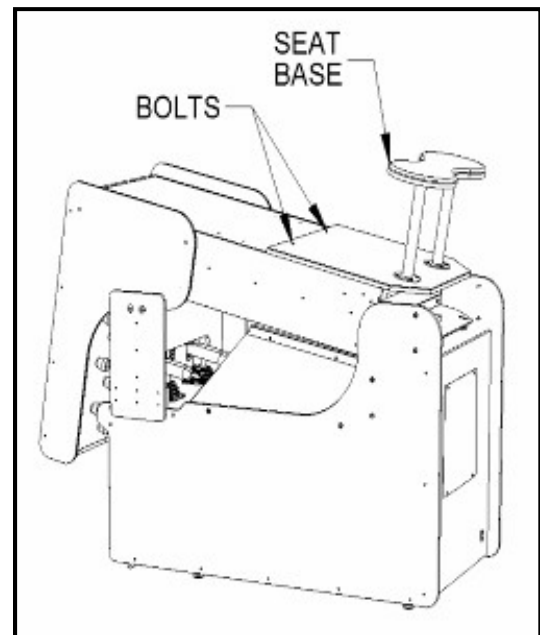

NOTE: ALTHOUGH ALMOST ALL MAINTENANCE IS DONE FROM THE FRONT OF THE GAME, WE WOULD RECOMMEND PLACING THE GAME AT LEAST 12" FROM THE WALL IN CASE IT IS NECESSARY TO ACCESS THE REAR PANELS.

WARNING: TO AVOID INJURY TO YOURSELF OR OTHERS, WE RECOMMEND THAT YOU HAVE AT LEAST 2 PEOPLE HELP TO SUPPORT THE REAR OF THE GAME WHILE CONNECTING THE FASTENERS.

4. Place the game in its final location and slowly raise the game into its upright position.

5. While 2 people hold the game vertically, open the coin door using the keys taped inside the return slot.
6. Remove the cash box to retrieve the connecting bolts and power cord.

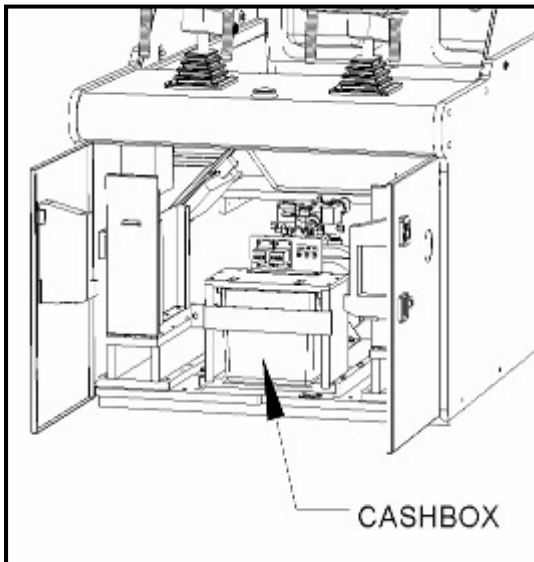

7. Push the upper cabinet fully back and secure the upper cabinet with the (4) mounting bolts and washers supplied.

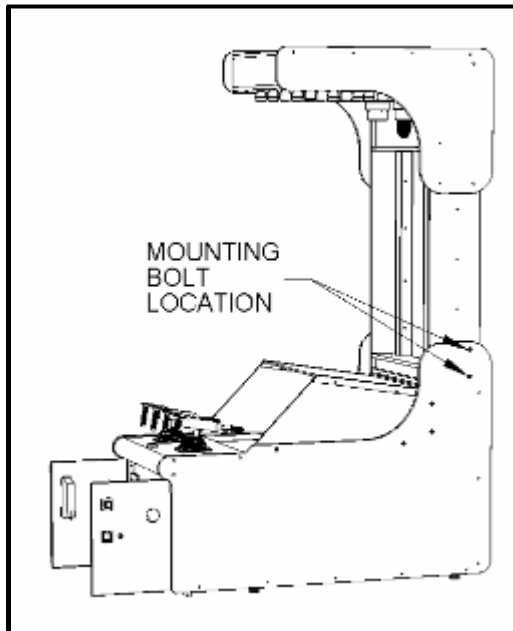

8. Close the doors to be sure they line up evenly and close securely. If either of the doors is lower than the other, raise the mounting foot on the side of the game with the lower door until the doors close evenly.

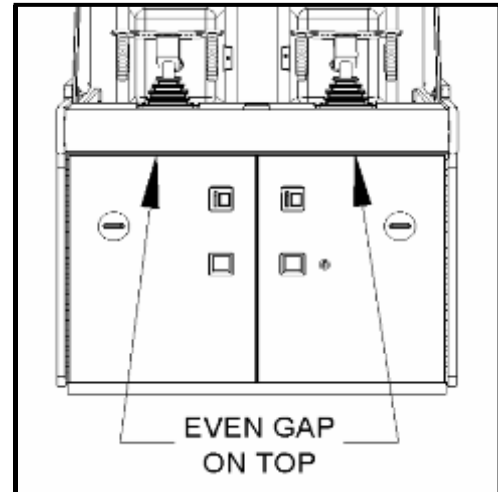

9. With the doors open, slide the seat base under the game until the holes in the base line up with the holes in the bottom of the cabinet.

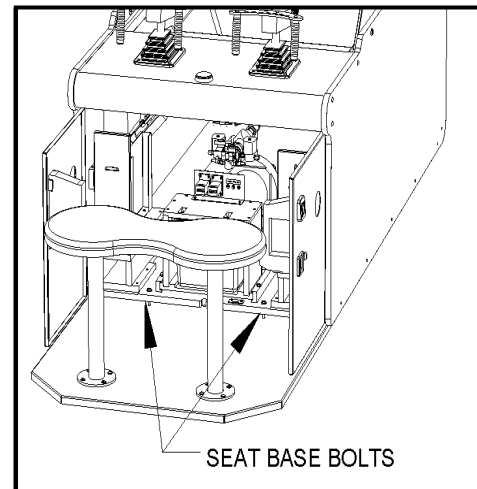

NOTE: JUST SCREW THE BOLTS INTO THE SEAT BASE ENOUGH TO HOLD IN PLACE DO NOT TIGHTEN DOWN OR THE SEAT BASE WILL LIFT UP. THIS FREE-FLOATING DESIGN ALLOWS THE SEAT BASE TO LEVEL TO THE FLOOR INDEPENDENTLY OF THE GAME.

10. Plug the game into a suitable A.C. Receptacle.
11. Turn the game on to be sure it powers up properly.
12. Remove the protective wrapping on the tank screen and set the screen into the tank.
13. Get a bucket with 5 gallons of water in it to fill the game reservoir.

NOTE: THE GAME COMES WITH AN ALCOHOL WATER MIXTURE TO PREVENT FREEZE DAMAGE WHEN SHIPPING IN COLD CLIMATES. THIS FLUID SHOULD BE WASHED OUT WHEN THE GAME IS SET-UP.

14. Fill the game tank with 5 gallons of water.

NOTE: ANY WATER CAN BE USED, HOWEVER USING DISTILLED WATER WILL KEEP YOUR GAME MUCH CLEANER AND SPOT FREE AND EXTEND YOUR WATER CHANGE INTERVALS.

15. Set the game's GAME / DRAIN valve to the drain position.

16. Press the PROGRAM button on the game's programming panel to access the programming options.

17. Press the OPTION button and advance to the DRAIN option.

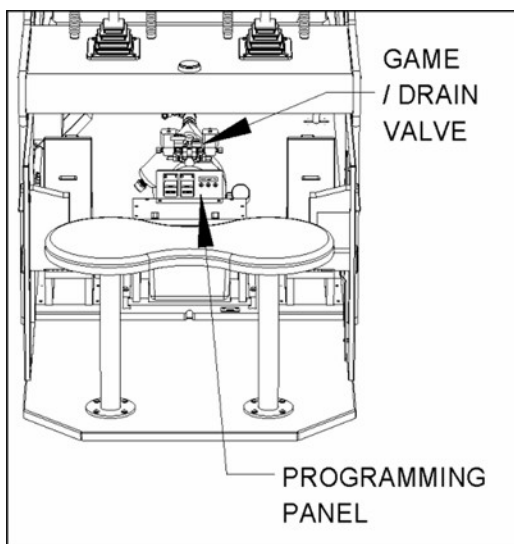

18. Press the VALUE button to turn the pump on and off.

NOTE: THE PUMP IS RUN ON A GROUND FAULT INTERRUPTER CIRCUIT. THIS IS TO PROVIDE A HIGH DEGREE OF SAFETY TO THE CUSTOMER. IF THE PUMP DOES NOT RUN WHEN THE GAME IS STARTED, CHECK THE RESET BUTTON ON THE GROUND FAULT OUTLET ON. THE RESET BUTTON MUST BE DEPRESSED DURING GAME PLAY TO BE ACTIVATED. PUSHING THE RESET BUTTON WHEN THE GAME IS OVER WILL NOT HAVE ANY EFFECT.

19. Hold the drain hose into the 5 gallon pail and press the VALUE button to start the pump.

20. Run the pump until the water comes out of the drain hose clear. TURN PUMP OFF.

21. Turn the GAME / DRAIN valve to the GAME position.

22. Start a 2 player game and check for proper operation of the guns.

NOTE: IT IS NORMAL FOR THE GUNS TO SPUTTER DURING THE FIRST GAME UNTIL ALL OF THE AIR IS PURGED FROM THE HOSES AND LINES.

23. Adjust the programming options as needed.

2. PROGRAMMING

2-1. ENTERING PROGRAMMING MODE:

The programming options are readable only by the game operator for the purpose of customizing the game to suit their location.

The operator will press the "PROGRAMMING" button once to enter the programming mode.

The operator will press the "SELECT" button to scroll through the various options that are on the left-hand display.

The operator will press the "STEP" button to scroll through the various settings for each option that are shown on the right-hand display.

The operator will press the "PROGRAMMING" button once again to EXIT the programming mode and save all of the new values to the games memory.

Below is detailed information for the operation of each of the programming options.

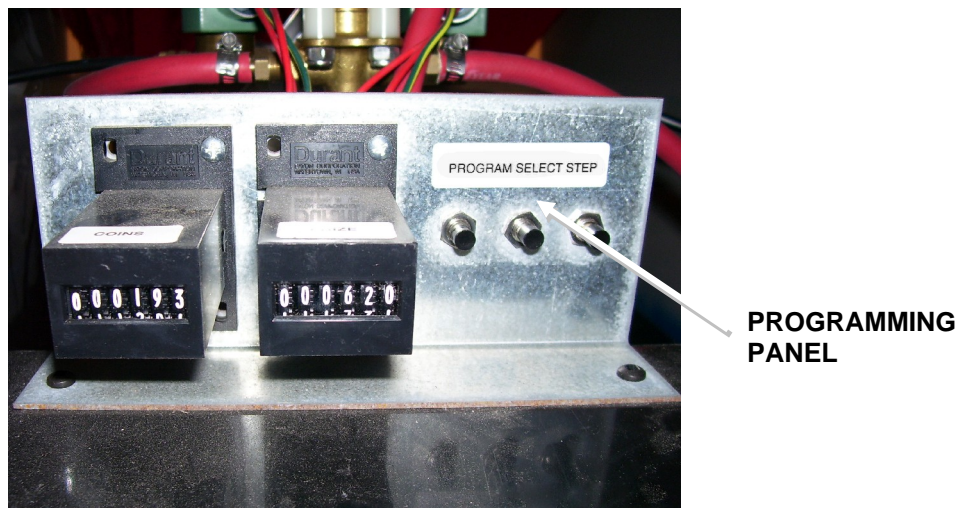

2-2. VOLUME:

This option controls the sound volume from the speaker on the front door of the game. The range for this option is 1-10 (10 being the loudest). The default value for this option is 3.

2-3. COINS PER CREDIT (COIN/CR):

This option determines how many coins are needed to earn a credit. Each credit will automatically start a game. The range for this option is 1-10; the default value for this option is 1.

NOTE: There is no "free play" option for this game. If free play is desired, set the game to 1 coin per credit and install a momentary contact push button to start the game.

2-4. ATTRACT MODE (ATTRACT TIME):

This option determines how often the attract sounds or (player taunting) will be heard from the game. The range for this option is 0-5 (minutes). Setting a 0 shuts the attract mode off. The default value for this option is 5.

2-5. JUST FOR PLAYING TICKETS:

This option determines how many tickets the player gets just for playing the game. The range for this option is 0-10. The default value for this option is "3".

2-6. WINNER TICKETS:

This option determines how many tickets the player gets for winning the game. The range for this option is 0-30. The default value for this option is "5".

2-7. GAME TIME TO WIN:

This option determines how many seconds it takes to win the game when the target is kept depressed. The range for this option is 5-20 seconds. The default value for this option is "12".

2-8. TIME OUT:

This option determines how many seconds of inactivity (target not depressed) are necessary for the game to automatically end. The range for this option is 30, 40, 50, 60, 70, 80 or 90 seconds. The default value for this option is "30". NOTE: If the game auto ends, the JUST FOR PLAYING tickets ONLY will be dispensed and there are no "winners".

2-9. DRAIN WATER:

This option is used as a convenient way to run the pump when setting up, changing water, or draining the game. Pressing the VALUE button will turn the pump on or off.

2-10. RESET: *(Default programming value - reset)*

This option will reset the game to factory default values. The range for this option is 0-1. Setting a "1" will reset the values to factory default. The default value for this option is "0".

2-11. PROGRAMMING OPTIONS:

STANDARD ARCADE OPTIONS				
REGISTER	MIN/MAX	BSR	ACTUAL	DESCRIPTION
Volume	1-10	3	_____	Volume Control
Coins/Credit	1-10	1	_____	Number of Coins per Game
Attract Mode	1-5	3	_____	Minutes Between Bally Music
Default Tickets	0-10	3	_____	Tickets Just for Playing
Winner Tickets	0-30	5	_____	Winning Tickets Per game
Time to Win	5-20	12	_____	Time to Win in Seconds
Time Out	30, 40, 50, 60, 70, 80, 90	30	_____	Time of Inactivity/Auto Win
Drain Water	0-1	On/Off	_____	Pump ON/OFF (Manual)
Reset Defaults	0-1	0	_____	Reset Factory Default Settings

2-12. REPROGRAM LINKING GAMES (ALSO COVERS HOW TO RESET SETTINGS):

(RESETTING THE BOARDS)

1. Unplug all the networking cables running from each board to another. (They are the cables that resemble phone cables)

- Go to the main control board (the board for players 1 and 2). Enter the programming mode by pressing the PROGRAMMING button. (The first black button on programming panel to the left)

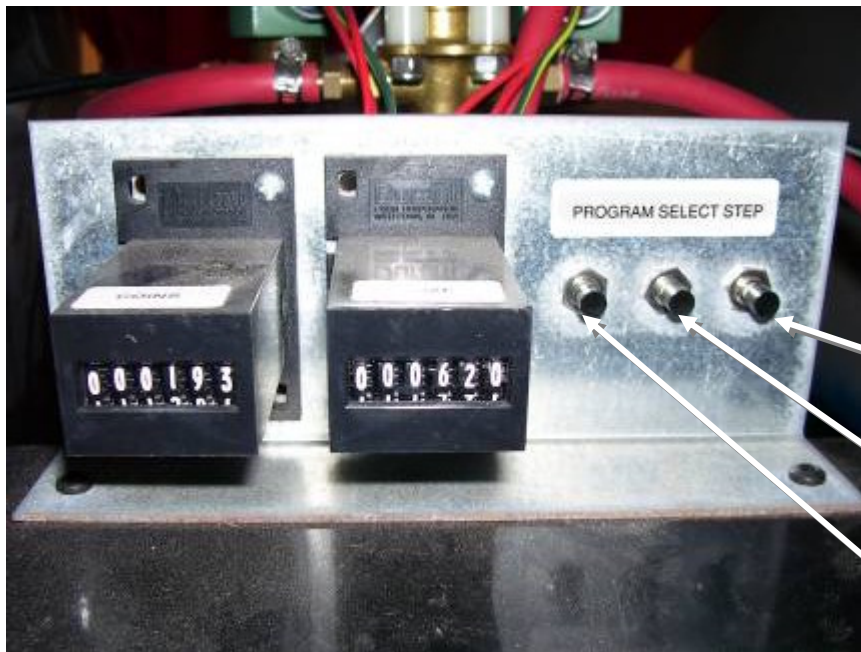

**PROGRAMMING
PANEL**

STEP Button

SELECT Button

PROGRAMMING Button

- After entering the programming mode, press the SELECT button (The center black button on the programming panel) until the first two front displays read "Reset Defaults".
- Once the first two front displays read "Reset Defaults" press the STEP button until the corresponding displays read a 1 at the bottom.
- To lock in the change to the settings press the SELECT button and then to exit the programming mode press the PROGRAM button.
- Proceed to the next control board and follow the exact steps for that board starting at step #2 above, and proceed through to step #5. (Continue in this fashion for the remainder of the boards.)

(REPROGRAMMING THE BOARDS)

- Once all stations have been reset, reconnect all of the phone cables to each board. The cables must be plugged into P11 or P12 phone jacks.

P11 & P12 PHONE JACKS

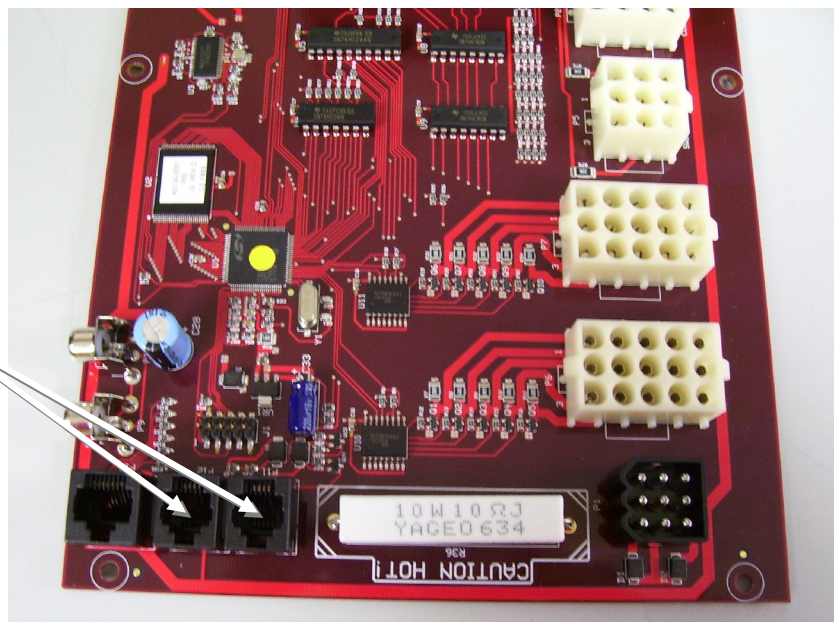

8. Once all the phone cables are plugged back into the proper jacks go back to the board one, which is the main control board (the board for players 1 and 2) and enter the programming mode once again by pressing the PROGRAMMING button on the programming panel. And press the SELECT button (The center button on the programming panel) until the corresponding displays read "Link ID".
9. Once "Link ID" is visible on the corresponding displays (If networked properly) the corresponding display should read a "1" to express that the board has been set to "board 1"
10. Proceed to the next boards control panel, make sure the corresponding displays still read "Link ID" and press the STEP button to set that specific board to show a 2 for board 2. (Do this for the following boards setting the "Link ID" to 3 for board 3 etc. etc. for however many boards your game has, up to 4 boards)
11. Go back to the main control board (the board for players 1 and 2) and press the PROGRAMMING button to get out of the programming mode.
12. Once the game links up and you see the displays go through a brief track mode (the game will light up several ways) you should see the displays list the unit #s 1-8 (for a 8 player game) at the bottom.

NOTE: TO RESET DEFAULTS FOLLOW INSTRUCTIONS STARTING AT #3GO INTO THE PROGRAMMING MODE AND PRESS THE SELECT UNTIL THE FIRST TWO FRONT DISPLAYS READ "RESET DEFAULTS" THEN PRESS THE "STEP" BUTTON.

3. MAINTENANCE AND TROUBLESHOOTING

3-1. Quick Troubleshooting:



WARNING

For your safety and to reduce risk of damage to your game read the Important Safety Information in Chapter 1-2 before attempting any troubleshooting procedure.

TROUBLESHOOTING PHILOSOPHY

When troubleshooting any product, certain general guidelines should be followed.

1. Always check to be sure that you game is turned on. Be sure that all of the fuses in the game are functional and check to see that the AC voltage is in the proper operating range for your game.
2. Check to be sure that all of the game harnessing is plugged in properly and that all of the pins are firmly seated in the connectors. It is always possible that a harness can be damaged by rough shipping or moving.
3. Check game harnessing to be sure that none of the wires have become damaged. Using a handheld multi-meter, check continuity of the wires to make sure they are not broken.
4. Check for obvious damage to any P.C. Boards or electrical components.
5. If you have multiple games or multiple parts on a game, change or exchange the parts and see if the problem goes away or moves to another location. This way you can quickly eliminate certain parts as being the problem with the game.
6. When changing electronic or electrical components, ALWAYS turn off and unplug the game.
7. Check to see that all power supplies are delivering the specified voltages to the P.C. Boards and components as shown in the manual.

For detailed servicing and repair information see the full the full repair section of this manual.

Symptom	Possible Problem	Solution
	Power	Power
Sound Problems -No sound -Low Sound -Intermittent Sound	Low Volume Faulty speaker harnessing Faulty speaker Faulty sound board or sound board harnessing Faulty Main P.C. Board	Check Volume Control and adjust as necessary Check connections and/or repair harnessing Check and/or replace speaker Check connections or Replace Sound Board Check and/or repair or replace Main P.C. Board
Game does not take or add money correctly	Coin switch out of adjustment Coin mech dirty or improperly adjusted Faulty Coin switch Faulty coin switch harness or connector Improperly programmed electronic mech Game improperly programmed Faulty Front Panel Board Faulty Main P.C. Board or component	Re-bend coin switch wire Clean and adjust mech as necessary Check and/or replace switch Check and/or repair harnessing Reprogram or replace electronic mech Check programming options and adjust Repair and/or replace Front Panel Board Repair and/or replace Main P.C. board
Ticket Dispenser not working properly, or no tickets being dispensed	No tickets in the game Tickets jammed in dispenser Ticket dispenser sensor blocked with debris Poor connection on the ticket dispenser Game improperly programmed Faulty ticket dispenser Faulty ticket dispenser harnessing Repair and/or replace Front Panel Board Faulty Main P.C. Board	Refill ticket dispenser and press the reset button Clear ticket jam Clean off sensor Check and/or replace connectors Check ticket programming options Replace dispenser Check and/or repair harnessing Faulty Front Panel Board Replace or repair Main P.C. Board
Game will not start or pump will not run	Game power off Main fuse blown Ground wire broken or loose Faulty coin switch GFI circuit tripped Faulty pump Power Supply problem or failure Faulty P.C. board or component	Check on/off switch and power cord Check and/or replace fuse as necessary Replace or tighten faulty ground wire Check coin switch Start game and push GFI reset button Check and replace pump Check Power Supply output and connections Repair and/or replace main P.C. board
Game stops or is stopped with nothing displayed	The power connector is disconnected. Possible faulty connection or short circuit.	Reconnect the connector securely. Check all circuitry for faulty connections or short circuits.
Water stream crooked or weak	Clogged gun tip Partially clogged filter Kinked hose Low water level or no water	Check and clean gun tip Check filter and clean if necessary Check all hoses Check water level and fill if necessary
Display lights won't move	Faulty target switch Faulty or disconnected harness Faulty Main P.C. board	Check target switch Check and repair harnessing Repair or replace main P.C. board
Water not coming out of gun	Clogged gun tip Kinked hose Low water level or no water Faulty solenoid valve GFI circuit tripped Faulty Pump Faulty Main P.C. board	Clean tip with paper clip Check hoses for kinks Check water level and fill if necessary Check or replace solenoid valve Start game and push GFI reset button Repair or replace pump Repair or replace Main P.C. Board
Programming button and counters	Disconnected programming Panel harness	Check connector Check connector

3-2. Maintenance:

Daily Maintenance:

1. TURN ON GAME POWER SWITCH
2. PHYSICALLY CHECK WATER LEVEL IN WATER TANK. IF THE WATER IS LOW OR BELOW THE FILL LINE FILL THE TANK. MAKE SURE THERE IS A MINIMUM OF 5 GALLONS IN THE TANK AT ALL TIME AND THE WATER IS ABOVE THE FILL LINE. *FOR INSTUCTIONS ON HOW TO FILL THE TANK SEE THE "FILLING THE WATER TANK" SECTION.*
3. CHECK TICKET LEVELS IN TICKET DISPENCERS BEFORE OPENING EACH DAY
4. CLEAN, WIPE DOWN, AND DRY OFF GAME NIGHTLY OR AS NEEDED
5. CHECK ALL LIGHT BULBS FOR WORKING ORDER (THIS INCLUDES TARGET PAN LIGHTS)
6. IT IS RECOMMENDED THAT YOU CLEAN THE WATER FILTER EVERY THREE DAYS OR AS NEEDED DEPENDING ON WATER CONDITION.

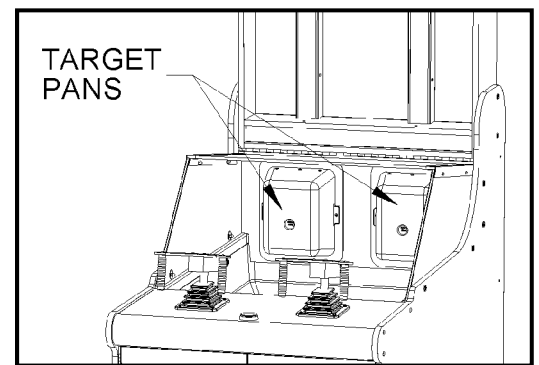

Weekly Maintenance:

1. CHECK THE WATER SYSTEM FOR DIRT AND DEBRIS.
2. IT IS RECOMMENDED THAT YOU CHANGE THE WATER SUPPLY ONCE A WEEK OR AS NEEDED DEPENDING ON WATER CONDITION. REMEMBER TO REMOVE THE FILTER CANISTER AND CLEAN SCREEN EACH TIME WATER IS CHANGED. *FOR INSTUCTIONS ON HOW TO EMPTY OR DRAIN THE WATER SEE THE "CHANGING THE WATER" SECTION.*
3. CHECK PLUMBING SYSTEM FOR LEAKS OR PLUMBING ISSUES.

Miscellaneous Maintenance:

1. CLEAN GUN TIPS OF ANY DEBRIS
NOTE: IF THE WATER GUNS ARE NOT SHOOTING STRONG OR STRAIGHT CLEAN THE GUN TIP. FOR INSTUCTIONS ON HOW TO CLEAN THE GUN PARTS SEE THE "CLEAN GUN PARTS" SECTION.

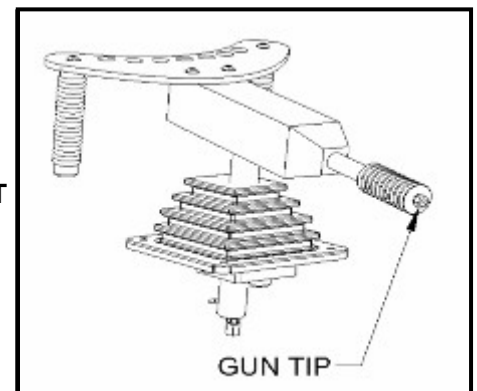

REMOVE TIP AND CLEAN WHEN GONE DOES NOT SHOOT WATER.

3-3. Detailed Troubleshooting and Repair:

3-3-1. Changing the Water:

1. Set the game's GAME / DRAIN valve to the drain position.
2. Press the PROGRAM button on the game's programming panel to access the programming options.
3. Press the OPTION button and advance to the DRAIN option.
4. Press the VALUE button to turn the pump on and off.

NOTE: THE PUMP IS RUN ON A GROUND FAULT INTERRUPTER CIRCUIT. THIS IS TO PROVIDE A HIGH DEGREE OF SAFETY TO THE CUSTOMER. IF THE PUMP DOESN'T RUN WHEN THE GAME IS STARTED, CHECK THE RESET BUTTON ON THE GROUND FAULT OUTLET ON. THE RESET BUTTON MUST BE DEPRESSED DURING GAME PLAY TO BE ACTIVATED. PUSHING THE RESET BUTTON WHEN THE GAME IS OVER WILL NOT HAVE ANY EFFECT.

5. Hold the drain hose into the 5 gallon pail and press the VALUE button to start the pump.
6. Run the pump until ALL of the water empties out of the tank. Turn off the pump
7. Turn the GAME / DRAIN valve to the GAME position when draining of the water is complete.
8. Remove the cash box assembly and slide the pump outside of the game to service and clean the filter assembly.
9. Remove the screen at the bottom of the tank and clean both the tank and the screen. Re-install the screen.
10. Add 5 gallons of water to a bucket and add 1 TBSP Cascade Dishwashing powder. (This will help keep the game clean). DO NOT use too much Cascade or foaming will result. Fill tank to proper level as required.

SUGGESTION: ALTHOUGH ANY WATER CAN BE USED, USE DISTILLED WATER WHENEVER POSSIBLE. DISTILLED WATER HAS ALL OF THE MINERALS REMOVED AND WILL DRASTICALLY EXTEND THE TIME INTERVAL BETWEEN WATER CHANGES.

11. Clean the inside of the glass with a plastic scrub pad to remove dirt and sediment from the glass.

NOTE: IF THE GLASS IS BADLY STAINED, USE C.L.R. MINERAL REMOVAL SPRAY FIRST TO GET RID OF TOUGH MINERAL DEPOSITS.

12. Spray RAIN-X on the inside of the glass to help prevent minerals from forming on the glass.
13. Press the PROGRAM button on the game's programming panel to access the programming options.
14. Press the OPTION button and advance to the DRAIN option.
15. Press the VALUE button to turn the pump on and off.
16. Hold the drain hose into the 5 gallon pail and press the VALUE button to start the pump.
17. Run the pump until the water comes out of both guns in a steady stream. Check game for any leaks and proper water pressure.
18. Turn the GAME / DRAIN valve to the GAME position; put 5 gallons of fresh water in game.

WARNING: BEFORE SLIDING PUMP BACK INTO PLACE, PLAY THE GAME, CHECKING FOR WATER LEAKS, AS THIS WILL CAUSE SEVER DAMAGE TO GAME.

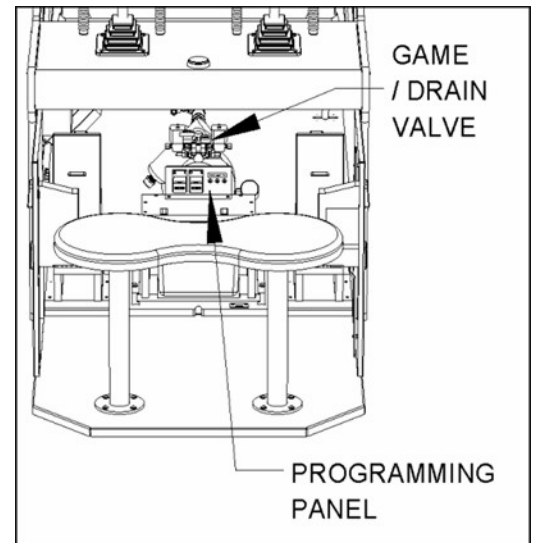

19. SLIDE PUMP ASSEMBLY BACK INTO POSITION AND REINSTALL COIN BOX ASSEMBLY WHEN PUMP SERVICE IS COMPLETED.

3-3-2. Glass Cleaning:

1. Clean the inside of the glass with a plastic scrub pad to remove dirt and sediment from the glass. DO NOT use any steel wool or scotch bright pads as these will damage the plastic side glass panels.

NOTE: IF THE GLASS IS BADLY STAINED, USE C.L.R. MINERAL REMOVAL. SPRAY FIRST TO GET RID OF TOUGH MINERAL DESPOSITS.

2. Spray RAIN-X on the inside of the glass to help prevent minerals from forming on the glass.

3. Clean the outside of the glass with any good commercial glass cleaner.

3-3-3. Draining the Water:

1. Set the game's GAME / DRAIN valve to the drain position.

2. Press the PROGRAM button on the game's programming panel to access the programming options.

3. Press the OPTION button and advance to the DRAIN option.

4. Press the VALUE button to turn the pump on and off.

NOTE: THE PUMP IS RUN ON A GROUND FAULT INTERRUPTER CIRCUIT. THIS IS TO PROVIDE A HIGH DEGREE OF SAFETY TO THE CUSTOMER. IF THE PUMP DOES NOT RUN WHEN THE GAME IS STARTED, CHECK THE RESET BUTTON ON THE GROUND FAULT OUTLET ON. THE RESET BUTTON MUST BE DEPRESSED DURING GAME PLAY TO BE ACTIVATED. PUSHING THE RESET BUTTON WHEN THE GAME IS OVER WILL NOT HAVE ANY EFFECT.

5. Hold the drain hose into the 5 gallon pail and press the VALUE button to start the pump.

6. Run the pump until ALL of the water empties out of the tank. Turn off the pump.

7. Turn the GAME / DRAIN valve to the GAME position.

8. Remove the screen at the bottom of the tank and clean both the tank and the screen. Re-install the screen.

3-3-4. Filling the Water Tank:

1. Add 5 gallons of water to a bucket and add 1 TBSP. Cascade Dishwashing powder. (This will help keep the glass clean). DO NOT use too much Cascade or foaming will result.

SUGGESTION: ALTHOUGH ANY WATER CAN BE USED, USE DISTILLED WATER WHENEVER POSSIBLE. DISTILLED WATER HAS ALL OF THE MINERALS REMOVED AND WILL DRASTICALLY EXTEND THE TIME INTERVAL BETWEEN WATER CHANGES.

2. Clean the inside of the glass with a plastic scrub pad to remove dirt and sediment from the glass.

NOTE: IF THE GLASS IS BADLY STAINED, USE C.L.R. MINERAL REMOVAL SPRAY FIRST TO GET RID OF TOUGH MINERAL DEPOSITS.

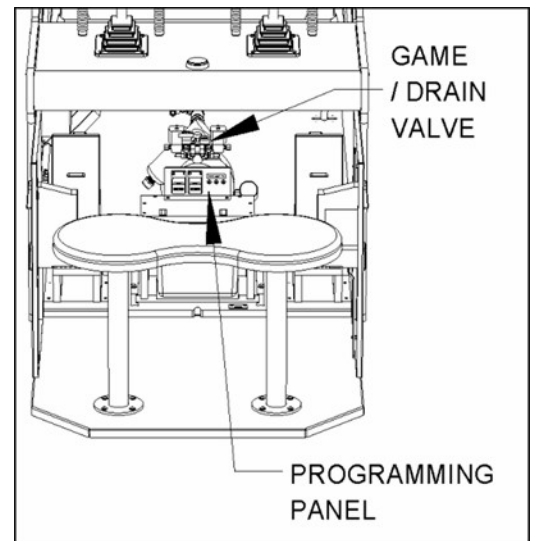

3. Spray RAIN-X on the inside of the glass to help prevent minerals from forming on the glass.
4. Fill the tank with the 5 gallons of water.
5. Set the game's GAME / DRAIN valve to the drain position.
6. Press the PROGRAM button on the game's programming panel to access the programming options.
7. Press the OPTION button and advance to the DRAIN option.
8. Press the VALUE button to turn the pump on and off.
9. Hold the drain hose into the 5 gallon pail and press the VALUE button to start the pump.
10. Run the pump until the water comes out.
11. Turn the GAME / DRAIN valve to the GAME position.
12. Play a couple of 2 player games to remove all of the air from the system.

3-3-5. Water Pump Removal:

1. DRAIN TANK AS DIRECTED ABOVE.
2. Open the front doors of the game and remove the bolts that hold the seat base to the game. (See image to the right)
3. Move the seat assembly out of the way.
4. Remove the cash box and remove the single bolt located in the bottom of the cash box enclosure. (See image below)

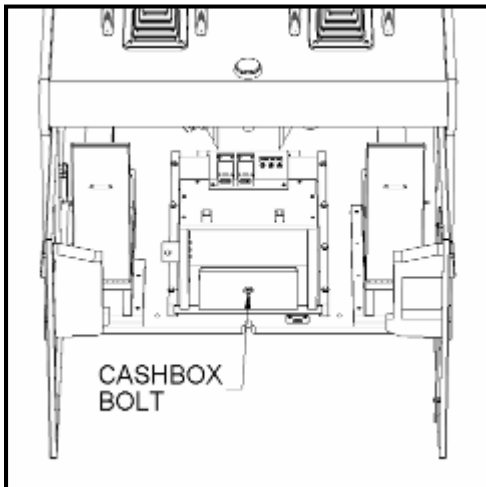
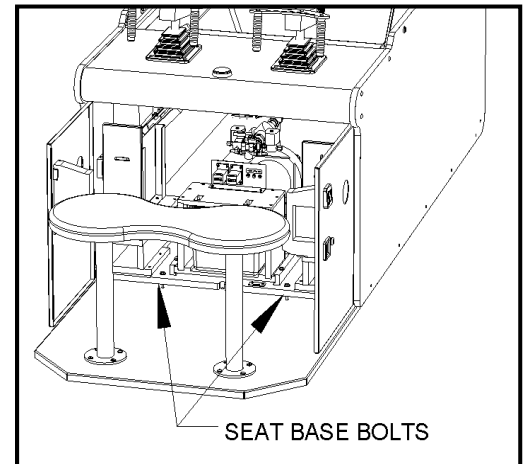

5. Slide the cash box enclosure out of the game and unplug the programming panel connector. Set the cash box enclosure to the side.
6. Carefully slide the pump assembly forward to access the pump. (See image below)

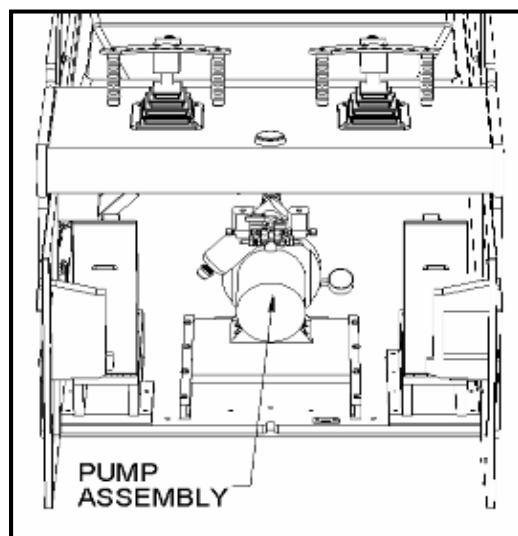

7. Unplug the solenoid harnesses and the A.C. Motor plug from the outlet in the upper left hand side of the cabinet.
(See image to the right)

NOTE: SERVICING OF THE SOLENOID VALVES CAN BE COMPLETED AT THIS STAGE OF REMOVAL. FOR FURTHER SERVICE CONTINUE TO REMOVE THE PUMP ASSEMBLY.

HAVE A SPONGE OR TOWEL AND SMALL BUCKET HANDY TO CATCH ANY DRIPS FROM THE HOSES.

8. Unscrew the small black hoses from the guns at the solenoids.
Wipe up any drips from the hoses.

9. Carefully pull the pump unit out of the game.

10. With a sharp knife, cut the large feed hose and small return hose as close to the pump fittings as possible.

IT IS NECESSARY TO CUT THE HOSES OFF, AS IT IS TOO DIFFICULT TO TRY TO PULL THEM OFF OF THE FITTINGS.

11. Remove the hose clamps and cut the remaining pieces of hose from the pump fittings

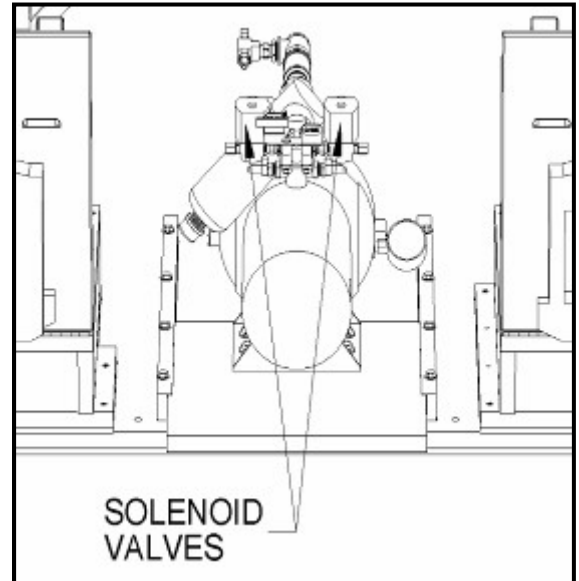

THE PUMP ASSEMBLY CAN NOW BE SERVICED OR REPLACED.

REPLACE ANY NECESSARY COMPONENTS MAKING SURE THAT ALL FITTINGS ARE SEALED WITH TEFLON TAPE.

3-3-6. Water Pump Installation:

1. Connect the feed and return hoses to the pump assembly. Leave the hose clamps loose at this time.

2. Slide the pump assembly back into the unit until it hits the rear stop.

3. Adjust the hoses to be sure that there are no kinks at all in the hoses. If there are any kinks, rotating the hoses will usually remove them.

4. TIGHTEN THE HOSE CLAMPS.

5. Reconnect the A.C. plug making sure that it is routed out of the way (behind ticket bin).

6. Re-install the solenoid harnesses by plugging in the connectors.

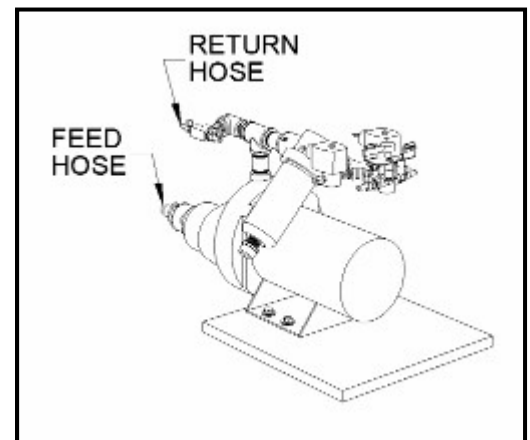

NOTE: THE HARNESS MARKED "161" GOES TO THE LEFT HAND SIDE AND THE HARNESS MARKED "162" GOES TO THE RIGHT HAND SIDE.

7. Re-install the cash box enclosure and reconnect the programming panel harness by plugging in the connector.

8. Re-install the small black hoses from the solenoid valves to the guns.

9. FILL THE WATER TANK AS DIRECTED ABOVE.

10. Re-install the cash box and bolt.

11. Re-install the seat assembly and bolts.

3-3-7. Cleaning Gun Parts:

It is possible after extended periods of time, or if the water you use is very high in mineral content, that you may have to clean deposits or debris from the gun assembly.

1. To clean the gun tip, try cleaning with a paper clip first. If that doesn't work, unscrew the tip to clean. (See image to the right)
2. For larger debris, unscrew the gun assembly from the top of the control panel. Disconnect the spring from underneath. (See image below)

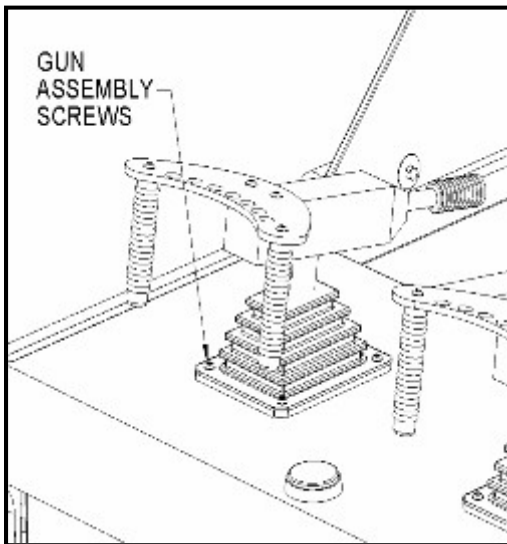
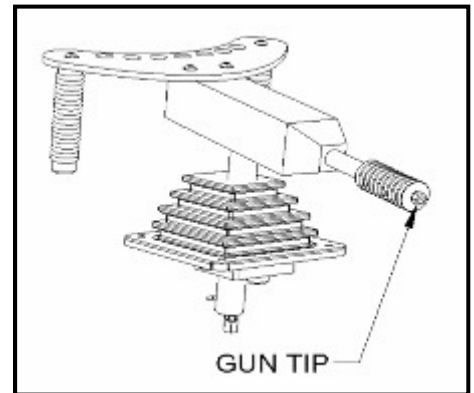

3. Remove the hose and nozzle tip from the gun.
4. Run a coat hanger or thick wire through the gun passages to remove any blockage.
5. With the tip off the gun, re-install the gun and connect the hose.
6. Play a few games to allow any debris to escape the gun body.
7. Re-install the gun tip and check for proper operation.

3-3-8. Target Sensors:

1. Remove the lower rear access door. (See image to the right)
2. Unscrew the target pans from the game. (See image below)

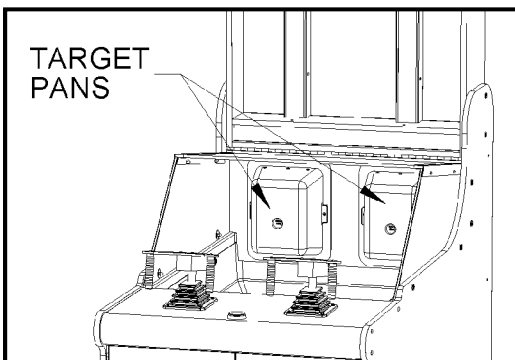
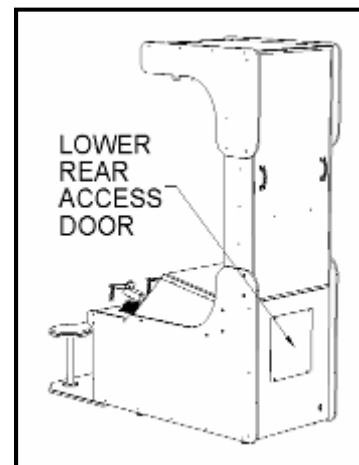

3. Unscrew the magnetic sensor from the clear polycarbonate window. (See image to the right)
4. Unplug the sensor.

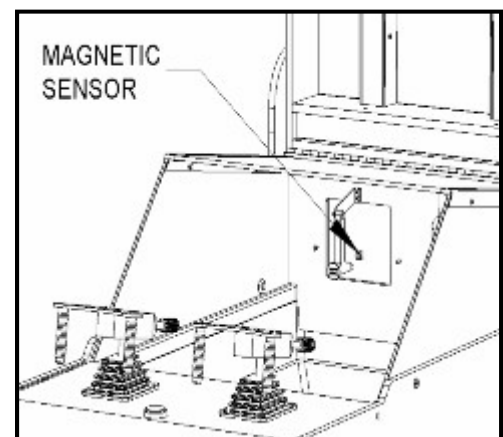

5. Re-install the new sensor using the other sensor as a guide to proper positioning. (See image to the right)
6. Check for proper alignment between the magnetic sensor and the magnet that is located on the target arm.
7. Re-install the target pan.
8. Play a couple of games to check for proper operation.
9. Re-install the lower rear access door.

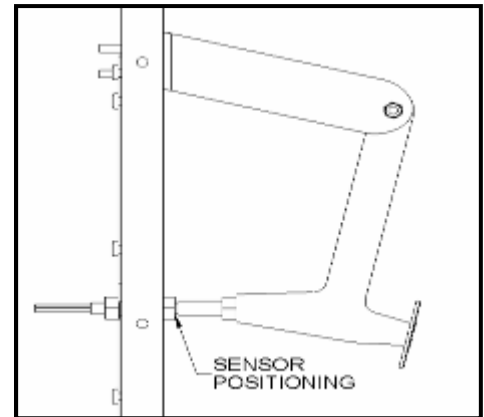

3-3-9. Main P.C. Board Removal and Installation:

ALTHOUGH THE MAIN P.C. BOARD CAN BE REMOVED THROUGH THE FRONT DOOR WITH THE SEAT AND CASH BOX ENCLOSURE IN PLACE, IT IS MUCH EASIER TO DO SO IF THEY ARE REMOVED FIRST. TO REMOVE THEM FOLLOW THE INSTRUCTIONS BELOW.

WARNING: BE SURE TO UNPLUG THE GAME BEFORE SERVICING TO AVOID SERIOUS INJURY OR DAMAGE TO THE GAME.

1. Open the front doors of the game and remove the bolts that hold the seat base to the game.
2. Move the seat assembly out of the way.
3. Remove the cash box and remove the single bolt located in the bottom of the cash box enclosure.
4. Slide the cash box enclosure out of the game and unplug the programming panel connector. Set the cash box enclosure to the side.
5. Unplug all of the connectors from the Main P.C. Board.
(See image to the right)
6. Unscrew the retaining clamp on the board mounting bracket and remove the board.
7. Install a new P.C. Board, making sure that the board engages the slots on the bottom of the mounting bracket.

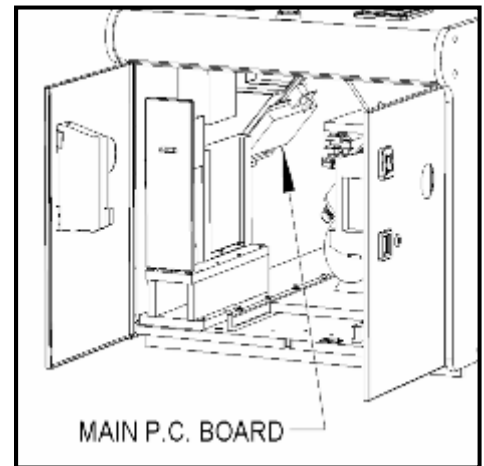

8. Tighten the P.C. Board retaining clamp.

NOTE: BE SURE THE CLAMP IS NOT CONTACTING ANY COMPONENTS ON THE BOARD OR SERIOUS DAMAGE MAY RESULT.

9. Re-install all of the connectors. Be sure they are inserted properly and that all of the connector locks are snapped into place.

NOTE: BEFORE CLOSING THE UNIT YOU WILL NEED TO REPROGRAM THE BOARDS IF THEY WERE LINKED TO OTHER GAMES. SEE THE PROGRAMMING SECTIONS FOR INSTRUCTIONS ON "REPROGRAM LINKING GAMES"

10. Re-install the cash box.
11. Re-install the seat assembly.

3-3-10. Display P.C. Board Removal and Installation:

ALTHOUGH THE CONNECTORS FOR THE DISPLAY P.C. BOARD CAN BE REMOVED THROUGH THE FRONT DOOR WITH THE SEAT AND CASH BOX ENCLOSURE IN PLACE, IT IS MUCH EASIER TO DO SO IF THEY ARE REMOVED FIRST. TO REMOVE THEM FOLLOW THE INSTRUCTIONS BELOW.

WARNING: BE SURE TO UNPLUG THE GAME BEFORE SERVICING TO AVOID SERIOUS INJURY OR DAMAGE TO THE GAME.

1. Open the front doors of the game and remove the bolt that holds the seat base to the game.
2. Move the seat assembly out of the way.
3. Remove the cash box and remove the single bolt located in the bottom of the cash box enclosure. (See image to the right)
4. Slide the cash box enclosure out of the game and unplug the programming panel connector. Set the cash box enclosure to the side.
5. Unplug the Appropriate harness from the Main P.C. Board. If it is the left hand display, unplug connector **P6** from the Main board. If it is the Right hand display, unplug **P7**.

NOTE: WHEN DISCONNECTING THE RIGHT HAND DISPLAY CONNECTOR (P7), BE SURE TO UNPLUG THE SINGLE WIRE FAST-ON CONNECTOR THAT IS RIGHT AT THE CONNECTOR AS WELL.

6. Remove the upper and lower rear access panels to be able to access the display harnessing. (See image to the right)

NOTE: THE DISPLAY HOUSING AND HARNESSING ARE REMOVED AND INSTALLED AS A SUB-ASSEMBLY.

7. Pull the display harness to the rear of the game and up through the cabinet holes.
8. Unbolt the display housing from the rear of the cabinet and pull straight out of the game.
9. Assemble in reverse order.

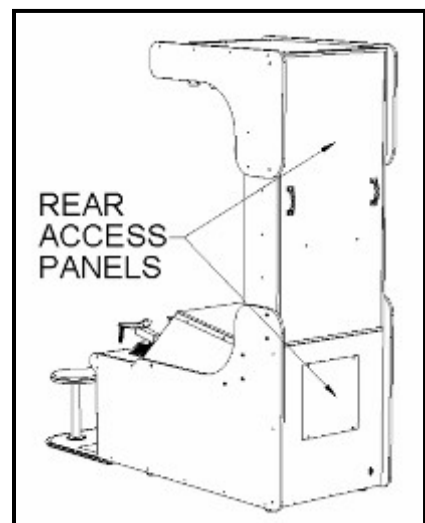
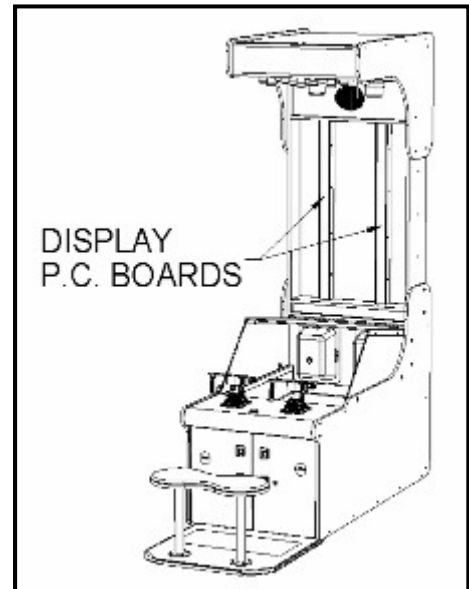

3-3-11. Display P.C. Board Servicing

1. Slide the display filter (Plexiglass cover) out of the housing.
2. Remove the 8 bolts that hold the Display mounting bracket to the Display housing. (See image to the right)
3. Slide the mounting bracket out of the housing.
4. Remove the connectors and defective display P.C. Board.
5. Assemble in reverse order.

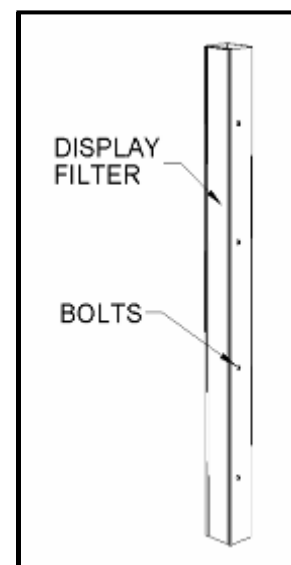

4. PARTS LISTING

MECHANICAL PARTS		ELECTRONIC / ELECTRICAL PARTS	
ARWB1003	TANK WATER STRAINER	ARWB2001-LINK	MAIN P.C. BOARD
ARWB1017	GUN BODY	ARWB2002	MAGNETIC TARGET SENSOR
ARWB1018	GUN HANDLE MOUNT	ARWB2003	TARGET MAGNET
ARWB1019	WATER GUN HANDLE	ARWB2004	MARQUEE LIGHT FLASHER UNIT
ARWB1020	GUN MOUNTING PLATE	ARWB6001	1/2 HP PUMP ONLY
ARWB1021	GUN BOOT BEZEL (STAINLESS)	E0025100	12 VOLT COUNTER
ARWB1022	CASH BOX HASP	E0027150	10 FT. POWER CORD
ARWB1025	TARGET MOUNTING BRACKET	COMPSTYLE	
ARWB1026	OUTER LEFT SIDE GLASS MTG BKT	E0028300	TURBO BULB (FLASHING LIGHTS)
ARWB1027	OUTER RIGHT SIDE GLASS MTG. BKT.	E0030630	BEACON LIGHT BASE
ARWB1029	INSIDE GLASS MOUNTING BRACKET	E0030632	BEACON LIGHT CHROME RING
ARWB3001	WATER GUN SWIVEL BLOCK	E0030635-RED	BEACON LIGHT RED DOME
ARWB3011	BENCH SEAT TOP	E0070012-CLR	LENS BODY (FLASHING LIGHTS)
ARWB3016	TARGET PIVOT SWING	E0070015-CL	CLEAR LENS CAP
ARWB3017	TARGET DISK	E0070016-BL	BLUE LENS CAP DOT
ARWB3020	SIDE WINDOW GLASS (SAR ACRYLIC)	E0070016-RED	RED LENS CAP DOT
ARWB3021	TOP GLASS (TEMPERED)	E0070016-YE	YELLOW LENS CAP DOT
ARWB6002	PRESSURE GAUGE	E0800040	WORKHORSE 6 BALLAST
ARWB6017	BULKHEAD (WATER PAN) DRAIN	E0800041	PL40 FLORESCENT BULB
ARWB9004	FULL PUMP ASSEMBLY	E0800044	BULB RETAINING CLIP
ARWB9013	FLASHER BULB PANEL COMPLETE	E0800070	6" X 9" SPEAKER
CX800085	DISPLAY FILTER (SMOKED GREY)	E0800157	DISPLAY P.C. BOARD
M0006905	GUN CENTERING SPRING	E0800201	200 WATT POWER SUPPLY
M0800035	CASH BOX	E0800310	SOLID STATE RELAY
M0800204	DELTRONICS 1275 TKT DISPENSER	EX800150	P.C. BOARD HOLDER
MX006103	GUN BARREL TIP	E0023880	FUSE, 15 AMPS SLO-BLO
MX006330	GUN BARREL		
MX007203	PAINTED TARGET PAN ASSEMBLY		
GRAPHICS / DECALS			
ARWB7001	SERVICE MANUAL		
ARWB7010	CABINET RIGHT SIDE DECAL SET		
ARWB7011	CABINET LEFT SIDE DECAL SET		
ARWB7012	CONTROL PANEL DECAL		
ARWB7013	MARQUEE DECAL		
ARWB7014	TICKET DISPENSER PLAYER 1 DECAL		
ARWB7015	DISPLAY MIRROR DECAL		
ARWB7016	TICKET DISPENSER PLAYER 2 DECAL		
ARWB7017	LEVER DECAL "DRAIN"		
ARWB7018	LEVER DECAL "GAME"		

Main P.C. Board (Linkable)
Part# ARWB2001-LINK

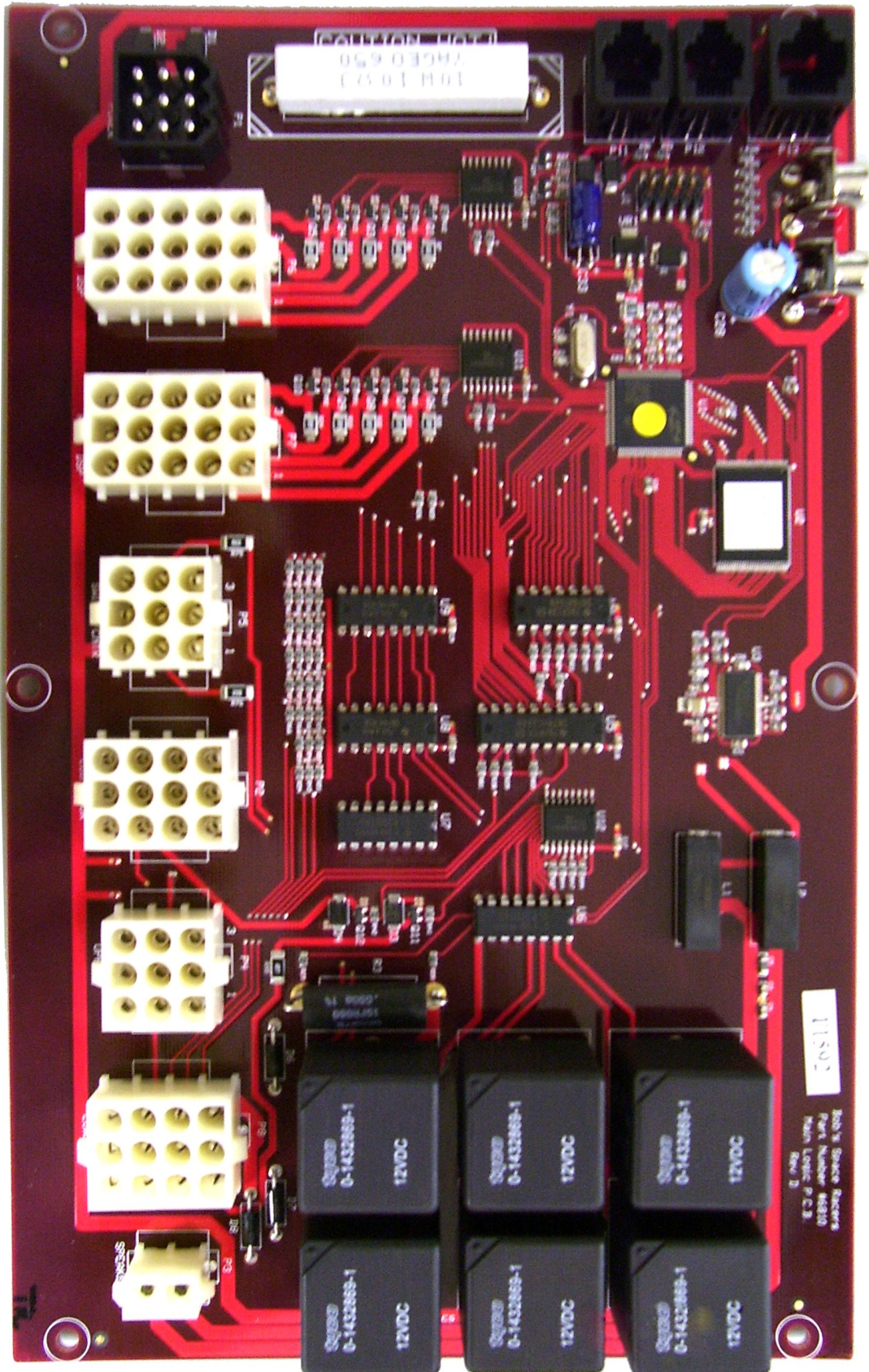

5. SCHEMATICS

Water Blast Wiring Harness

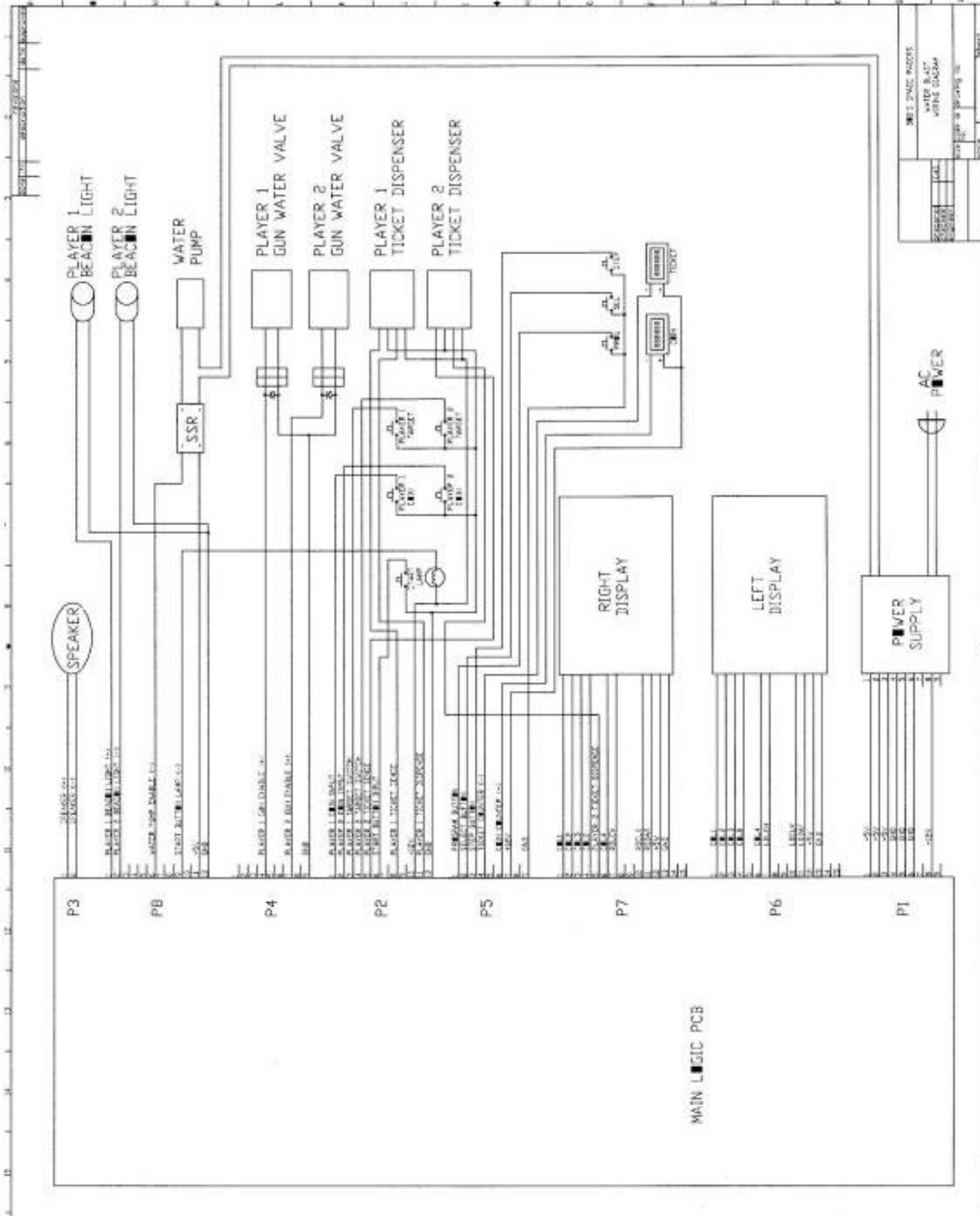

Board Schematic #2

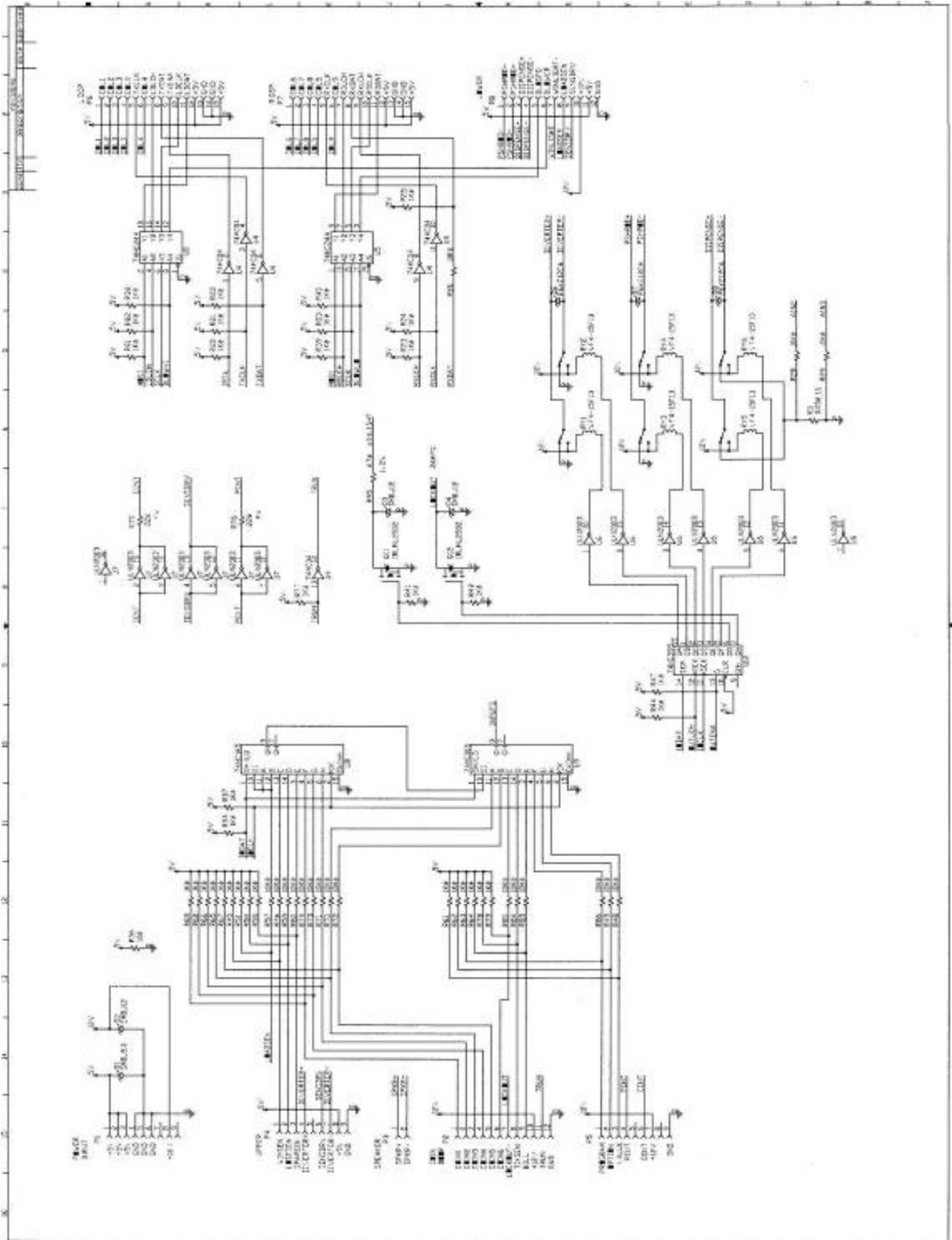

LED Display Schematic

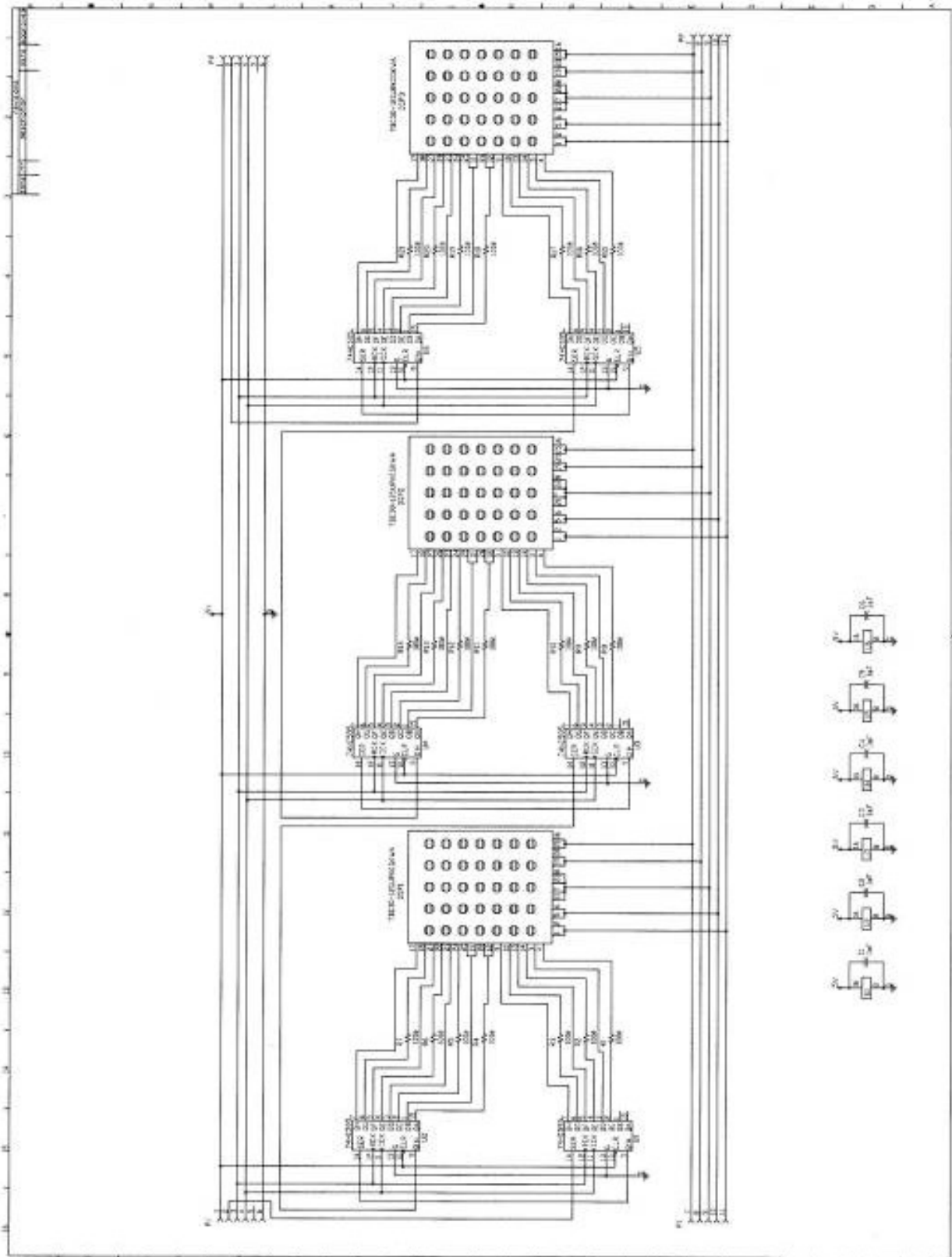

6. WARRANTY

BOB'S SPACE RACERS INC. 90 DAY COIN-OPERATED GAME WARRANTY

1. INCLUDED IN THIS WARRANTY Bob's Space Racers®, Inc. warrants to the original purchaser only that the equipment that is the subject of this sale conforms to its specifications, and is free from defects under normal service for a 90 day period from the original date of deliver. This warranty does not include any damages resulting from occurrences listed in paragraph 2 below. This warranty is not transferable under any circumstance. Any claims under this warranty must be received in writing by Bob's Space Racers®, Inc. within 120 days from date of delivery. Within a reasonable time of such written notification Bob's Space Racers®, Inc. will replace or repair any defective component of the equipment or part thereof which fails for reasons other than normal service, use, or wear. Bob's Space Racers®, Inc. reserves the right to request dated proof of purchase by the end user (original purchaser) at any time. Light bulbs are specifically excluded from this warranty and shall be the sole responsibility of the purchaser. Bob's Space Racers®, Inc., within its sole discretion, makes the final determination as to whether to repair or replace any component and whether any such repair or replacement shall be performed where the equipment is located or at its home facility in Volusia County, Florida, or another facility of its sole choice. Any and all freight charges for the purposes of repair or replacement shall be paid by the original purchaser. All defective parts shall be returned to Bob's Space Racers®, Inc. if requested. Bob's Space Racers®, Inc. does not warrant that the equipment will meet any original purchaser's specific requirements or that the operation of the equipment will be uninterrupted. These remedies are the original purchaser's exclusive remedies for breach of warranty.
2. EXCLUDED BY THIS WARRANTY Bob's Space Racers®, Inc. does not warrant (a) any product, components or parts not manufactured by Bob's Space Racers®, Inc.; (b) damages caused by use of the equipment for purposes other than those for which it was designed; (c) defects caused by failure to provide a suitable installation environment for the equipment; (d) damage caused by unauthorized attachments, modification, or service; (e) damage caused by normal wear and tear or improper power supply; (f) damage caused by accident or disaster such as fires, flood, lightning, and wind; or (g) any other abuse or misuse of the equipment.
3. EXCLUSIVE WARRANTY. THE FORGOING WARRANTY IS EXCLUSIVE AND IN LIEU OF ALL OTHER WARRANTIES OR REMEDIES, WHETHER WRITTEN, ORAL OR IMPLIED. THERE ARE NO WARRANTIES WHICH EXTEND BEYOND THE DESCRIPTION ON THE FACE HEREOF. ANY AND ALL IMPLIED WARRANTIES OF MERCHANTABILITY, FITNESS FOR A PARTICULAR PURPOSE, COURSE OF DEALING OR USAGE OF TRADE ARE HEREBY EXPRESSLY DISCLAIMED AND EXCLUDED.
4. REMEDIES LIMITED. UNDER NO CIRCUMSTANCES, EXCEPT TO THE EXTENT PROHIBITED BY APPLICABLE LAW, SHALL BOB'S SPACE RACERS®, INC. BE LIABLE FOR ANY LOSS OR DAMAGE, DIRECT OR INDIRECT, SPECIAL INCIDENTAL OR CONSEQUENTIAL ARISING OUT OF THE USE OR INABILITY TO USE THIS EQUIPMENT INCLUDING BUT NOT LIMITED TO ANY CLAIM FOR LOSS OR PROFITS, LOSS OF SAVINGS OR REVENUE, LOSS OF USE OF THE EQUIPMENT, OR ANY ASSOCIATED EQUIPMENT, FACILITIES OR SERVICE, DOWNTIME, THE CLAIMS OR COSTS OF THIRD PARTIES INCLUDING CUSTOMERS AND INJURY TO PROPERTY. Some states do not allow limitations on how long an implied warranty lasts or the exclusion or limitation of incidental or consequential damages, so the above limitations or exclusion may not apply to you. This warranty gives you specific legal rights, and you may also have other rights which vary from state to state.
5. NO OTHER WARRANTIES. Unless modified in writing and signed by both parties, this agreement is understood to be the complete and exclusive agreement between the parties, superseding all prior agreements, oral or written, and all other communications between the parties relating to the subject matter of this agreement. No employee or representative of Bob's Space Racers®, Inc. or any other party is authorized to make any other warranty or to assume any other liability in connection with the sale of its equipment.
6. TIME LIMIT FOR CLAIMS. Any claim for breach of warranty or claims under this warranty must be received in writing by Bob's Space Racers®, Inc. within 120 days following delivery of the equipment.
7. FUTURE CHANGES. Bob's Space Racers®, Inc. reserves the right to reserve, change or modify the construction and design of its equipment or any component part or parts thereof without incurring the obligations to make such changes or modifications in present equipment.
8. ALLOCATION OF RISKS. This agreement allocates the risks of equipment failure between Bob's Space Racers®, Inc. and the original purchaser. This allocation is recognized by both parties and is reflected in the price of the goods. THE PURCHASER ACKNOWLEDGES THAT IT HAS READ THIS AGREEMENT, UNDERSTANDS IT, AND IS BOUND BY ITS TERMS.
9. TO OBTAIN WARRANTY SERVICE. The original purchaser must, at his/her own expense, bring or ship the equipment to an authorized location for service. Additionally, the original purchaser must pay all freight, shipping or transportation charges for the return of the equipment from Bob's Space Racers®, Inc. to the original purchaser. Telephone or write:

Bob's Space Racers®, Inc.
427 15th Street
Daytona Beach, FL 32117
Telephone number: 386/677-0761
FAX: 386/677-0794

WHEN CALLING FOR SERVICE

1. When calling for service, please check the service manual first. Many times the answer to your problem has been addressed in this documentation.
2. Please make sure you have the serial number of the game ready when you call.
3. If this is a repeat call, please tell the service technician that you have made a previous call regarding this problem. This way we will be able to retrieve the history on your game allowing us to serve you better and save you time.
4. Please retain proof of purchase for your product. This might be requested for warranty repairs.
5. Please call from the game if possible since we might need you to check certain things on the game while we are on the telephone with you.

IF YOU HAVE ANY QUESTIONS OR COMMENTS, PLEASE CALL OUR SERVICE DEPARTMENT AT

(386) 677-0761

(MONDAY – FRIDAY, 8:30AM – 5:00PM EST, EXCLUDING HOLIDAYS)

(or)

EMAIL QUESTIONS TO: Tech@BobsSpaceRacers.com

(or)

**VISIT THE “CUSTOMER SUPPORT” SECTION ON OUR WEBSITE:
WWW.BOBSSPACERACERS.COM**

WATER BLAST

Fill Level Update (6/13/07)

NOTE: THIS UPDATE WILL ALLOW FOR THE PROPER FILLING LIMIT OF THE WATER BLAST GAME'S WATER TANK.

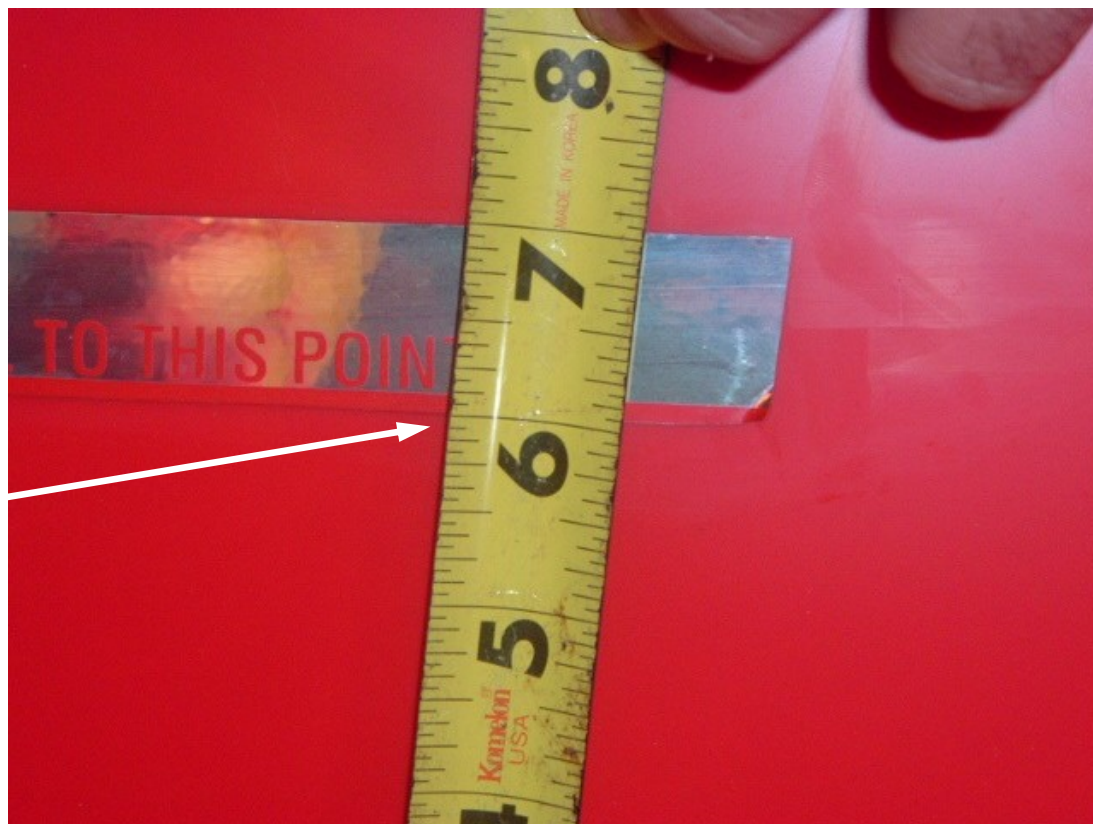

Correct fill distance

- INSTALL DECAL (AS SEEN IN THE ABOVE IMAGE) 6" FROM THE BOTTOM OF TANK.

WATER BLAST

Ventilation Update (6/13/07)

NOTE: THIS UPDATE WILL ALLOW FOR BETTER VENTILATION OF YOUR WATER BLAST GAME.

IMAGE 1



IMAGE 2

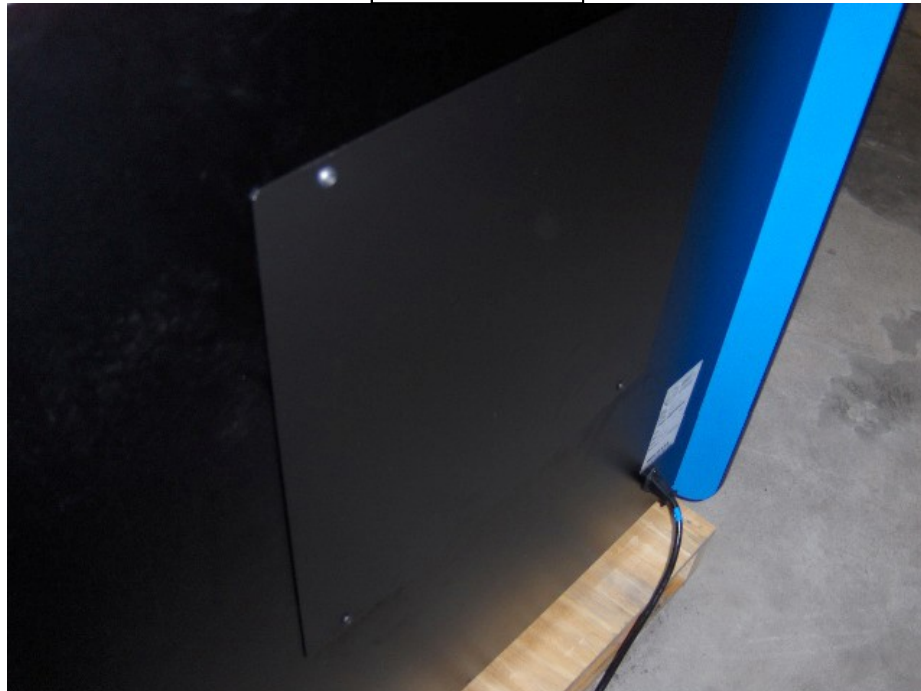

- If You Find That The Rear Metal Access Plate **Is Bolted Directly To The Game** (As Shown In “Image 1” And “Image 2”), Unbolt It And Insert Spacers, Washers, Or Nuts To Separate The Door/Plate From The Game. Be Sure To Evenly Space Each Bolt When Attaching The Rear Access Plate To The Game, So As To Not Bend It. Recommended Spacing Is A $\frac{1}{4}$ " To $\frac{1}{2}$ ". When Finished The Game Should Look Like “Image 3” And “Image 4”.

IMAGE 3



IMAGE 4



WATER BLAST

Water Change & Filter Cleaning Service (6/27/07)

NOTE: THIS UPDATE EXPLAINS HOW TO CHANGE THE WATER OF YOUR WATER BLAST GAME.

Water And Filter Should Be Cleaned Twice A Month, Or Every Two Weeks.

1. Turn off and unplug power to avoid risk of shock.
2. Open the front Coin/Ticket doors.
3. Remove the Coin Drawer. (Image 1)

IMAGE 1

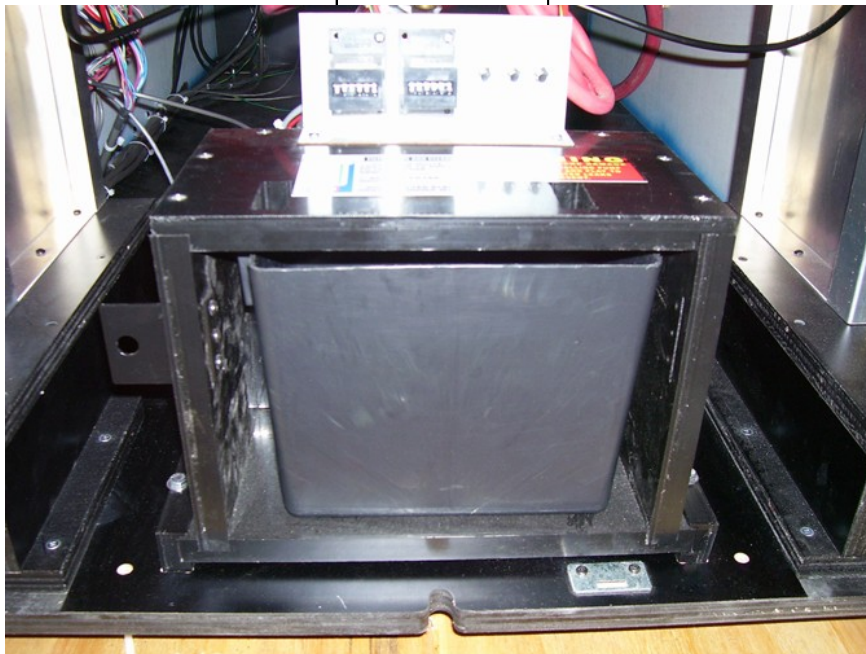

4. Locate and remove the allen bolt from the bottom of the Coin Box. (Image 2)

IMAGE 2



- Slide the Coin Box out of the game. Place it on the left side. (Image 3)

IMAGE 3

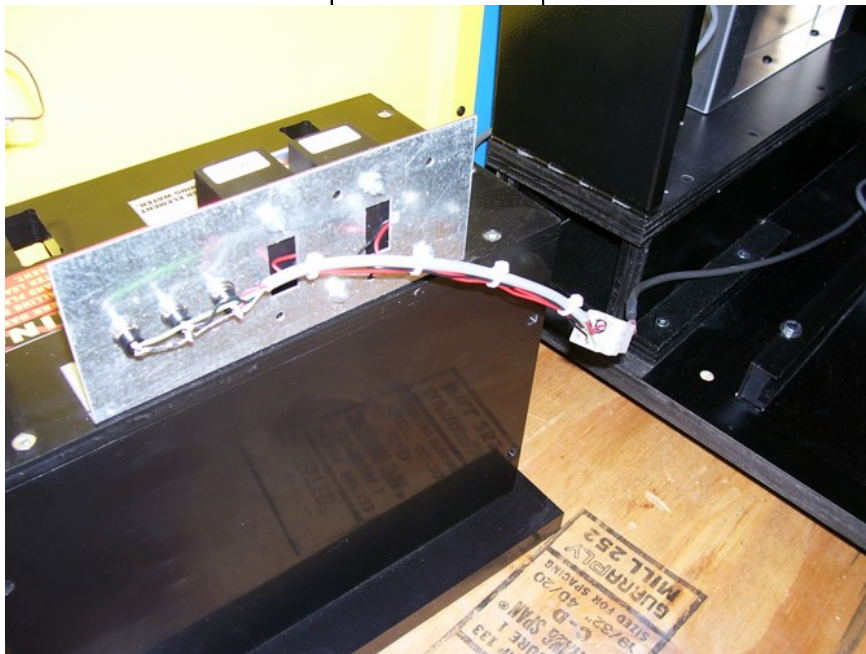

- Slide the Pump Assembly forward. Be careful not to kink any hoses or pull any wires. (Image 4)

IMAGE 4

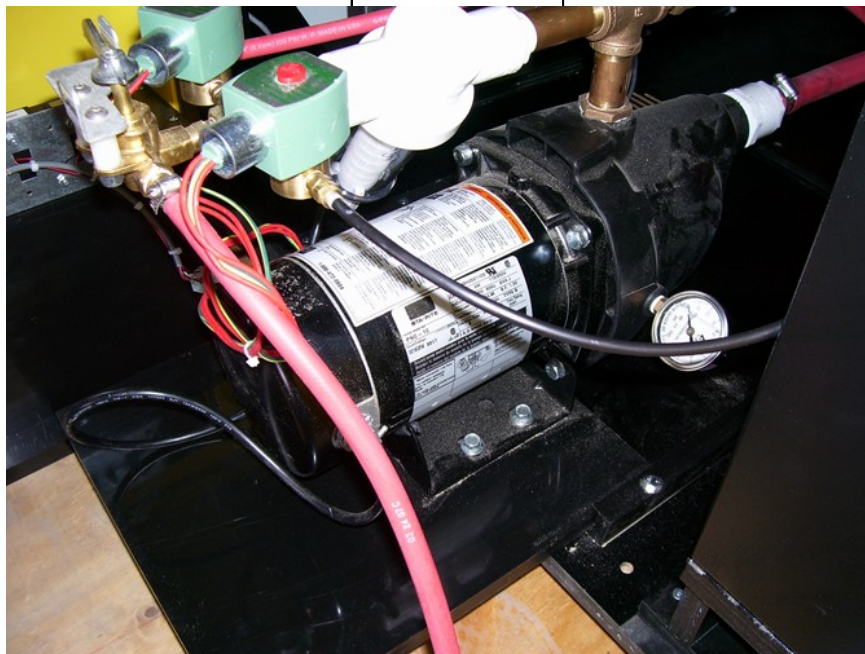

7. Turn the GAME/DRAIN Valve to the DRAIN position. (Image 5)

IMAGE 5



8. Hold the drain hose in a bucket. Using the PROGRAMMING Panel. Press PROGRAM. Press SELECT until DRAIN is displayed. Press STEP. The pump will turn on and start to fill the bucket.
9. Press STEP again to turn pump off. DO NOT RUN THE PUMP DRY.
10. Once the tank is empty, turn the DRAIN/GAME valve to GAME. (Image 6)

IMAGE 6

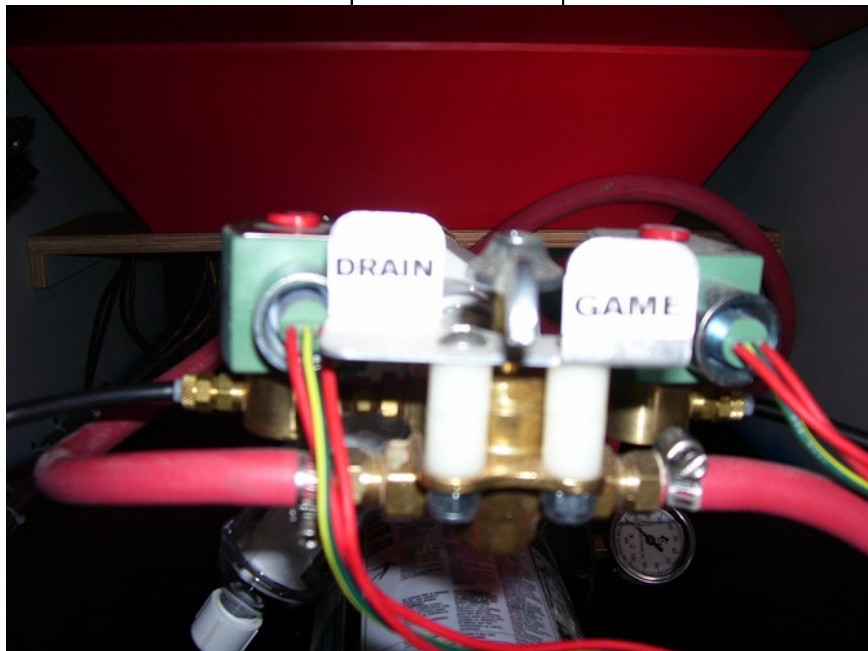

11. Press the PROGRAM button.
12. Unplug the pump from AC power outlet in game.

13. Unscrew the Clear-Vu filter. (Image 7)

IMAGE 7

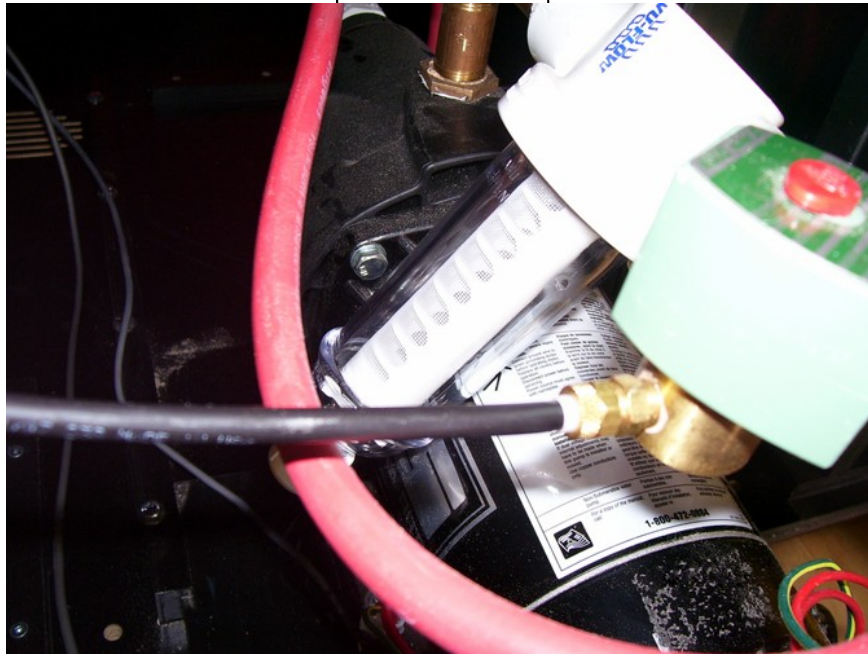

14. Clean the bowl and the filter cartridge using a soft brush and mild detergent. (Image 8)

IMAGE 8



15. Carefully insert the filter cartridge into the base and screw on the bowl. DO NOT OVER TIGHTEN.

16. Plug the pump into AC power outlet in game.

17. Fill tank to the FILL LINE. The water should be 6 inches deep minimum. (Image 9)

IMAGE 9



18. Coin up the game and press PUSH TO START.
19. Play the game a few times to let the pump circulate the water.
20. INSPECT THE PUMP FOR ANY LEAKS before installing in the game.(Image 10)

IMAGE 10

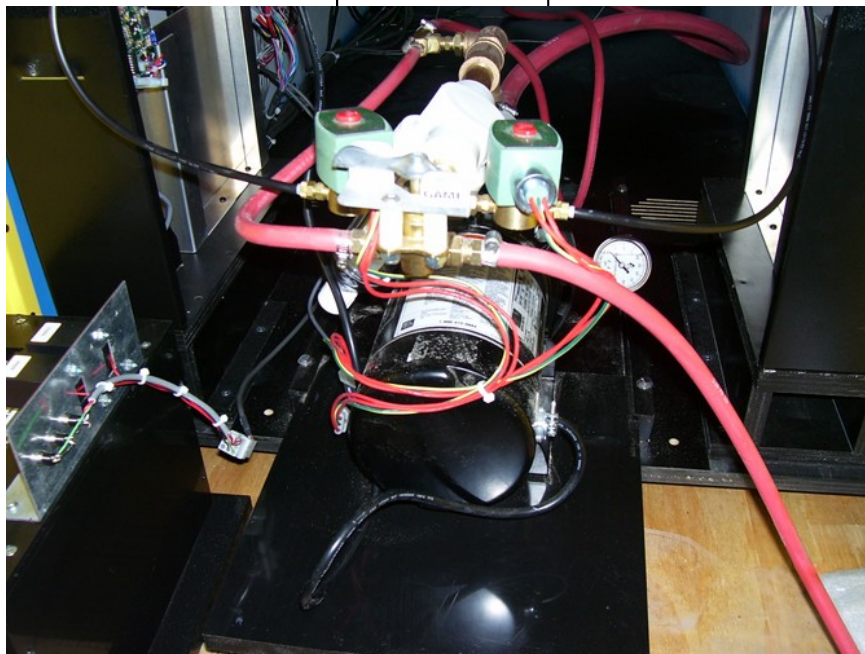

21. Slide Pump Assembly back into the game.
22. Slide the Coin Box Assembly back into the game.

23. Install allen bolt in bottom of Coin Box Assembly.
24. Install Coin Drawer.
25. Inspect the inside of the game for any loose wires or water damage before closing.

IMAGE 11



26. Shut the Coin/Ticket doors and lock them.
27. Re-plug power and turn on. (Play a test game to make sure game is working properly)

IF YOU HAVE ANY QUESTIONS OR COMMENTS, PLEASE CALL OUR SERVICE DEPARTMENT AT

1-386-677-0761

(or)

EMAIL QUESTIONS TO: Tech@BobsSpaceRacers.com

WATER BLAST

OPERATION MANUAL



WARNING

Be sure to read this Operation Manual before using your machine to ensure safe operation.

©2008 Bob's Space Racers Incorporated

427 15th STREET • DAYTONA BEACH • FLORIDA • 32117

PHONE **386-677-0761** FAX **386-677-0794**

BOBSSPACERACERS.COM

NOVEMBER 2008

©2008 BOB'S SPACE RACERS INC.

WATER BLAST™ ARCADE



TABLE OF CONTENTS

1. INTRODUCTION

- 1-1. Overview and Technical Features:
- 1-2. Important Safety Information:

2. PROGRAMMING

- 2-1. Entering Programming Mode:
- 2-2. Volume:
- 2-3. Coins per Credit:
- 2-4. Attract Mode:
- 2-5. Just for Playing Tickets:
- 2-6. Winner Tickets:
- 2-7. Game Time to Win:
- 2-8. Time Out:
- 2-9. Drain Water:
- 2-10. Money:
- 2-11. Reset Defaults:
- 2-12. Programming Options:

3. MAINTENANCE AND TROUBLESHOOTING

- 3-1. Quick Troubleshooting:
- 3-2. Maintenance:
- 3-3. Detailed Troubleshooting and Repair:
 - 3-3-1. Changing the Water:
 - 3-3-2. Glass Cleaning:
 - 3-3-3. Draining the Water Tank:
 - 3-3-4. Filling the Water Tank:
 - 3-3-5. Water Pump Removal:
 - 3-3-6. Water Pump Installation:
 - 3-3-7. Cleaning Gun Parts:
 - 3-3-8. Target Sensors:
 - 3-3-9. Main P.C. Board Removal and Installation:
 - 3-3-10. Display P.C. Board Removal and Installation:
 - 3-3-11. Display P.C. Board Servicing:

4. PARTS LISTINGS

5. SCHEMATICS

6. WARRANTY

1. INTRODUCTION

1-1. Overview and Technical Features:

Thank you for purchasing the new WATER BLAST™ from Bob's Space Racers®. Built on a long tradition of value, the WATER BLAST™ retains all of the great game play you have come to expect from a game from BSR. It has been designed and engineered by taking years of experience in producing industry leading Water games and combining this experience with modern manufacturing technology developed for this application. All of this is brought together to provide the operator and customer with the best possible experience.

FEATURES

FOLDING DESIGN - The new cabinet folds up for easy and fast assembly. The game can be assembled and ready to play in as little as 15 minutes.

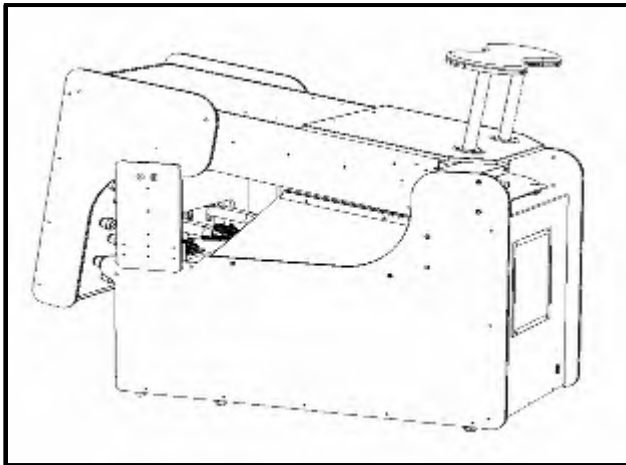

WATER SHIELD - The new water shield has a tempered glass top and scratch resistant acrylic sides for years of service. This design can be washed over and over and still retain its like new appearance.

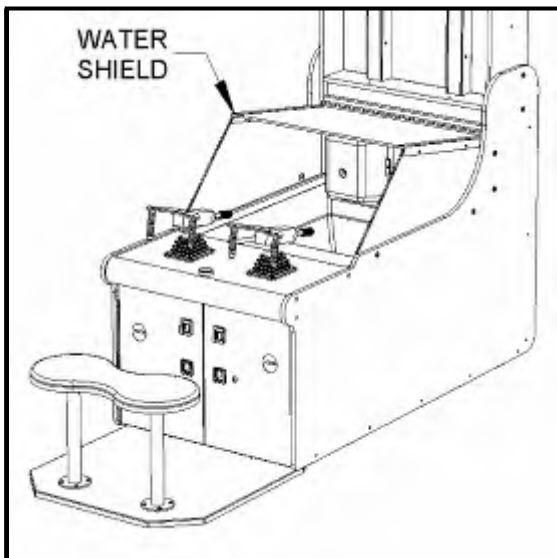

WATER TANK - The new water tank is made from vacuum formed molded plastic with smoothly rounded corners. This tank will look great for years to come and is very easy to clean.

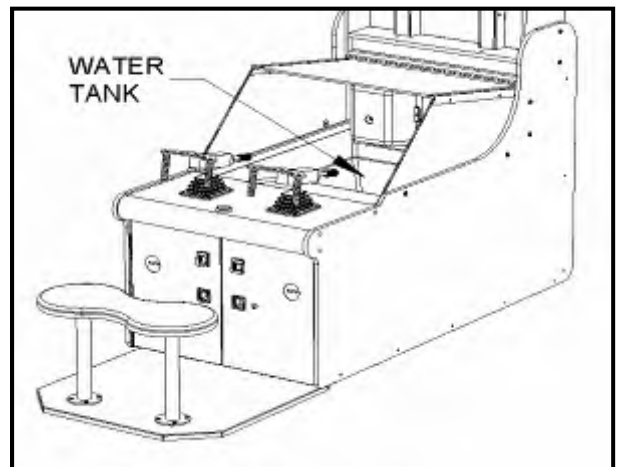

UP FRONT ACCESS - All servicing of the game can be done through the front doors. This eliminates having to move the game away from the wall for access to the pump and electronic components. For example, removing 1 bolt from the cash box enclosure makes it possible to slide the pump unit right out through the front door

WATER PUMP ASSEMBLY - The water pump assembly uses an all plastic impeller and housing to completely eliminate any rusting or corrosion in the water system. This greatly extends the time between water changes. The pump assembly also uses a basket type washable water filter in a clear-view housing to keep the game working properly. The entire pump assembly can be easily removed from the game making bench top servicing possible. *(Picture on next page)*

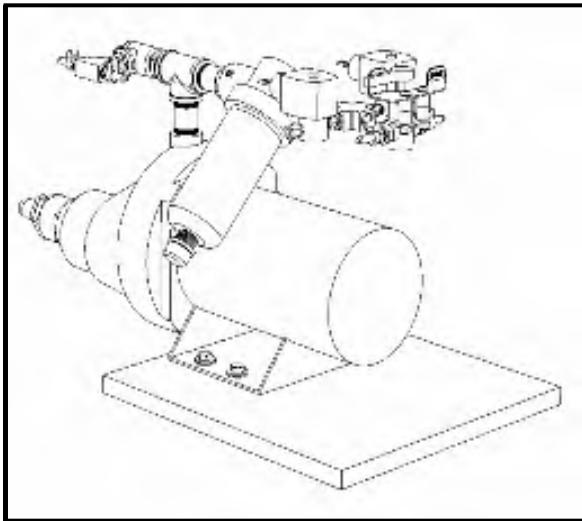

SCORE DISPLAYS - The solid state score displays are replaceable as a sub-assembly making service easier.

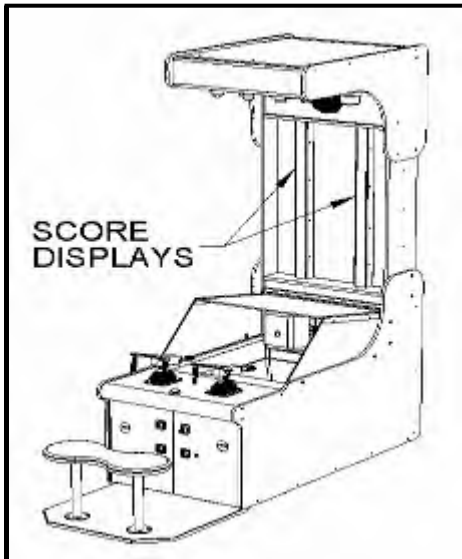

SIMPLE ELECTRONICS - The new design uses only 1 electronic board making troubleshooting far easier than ever.

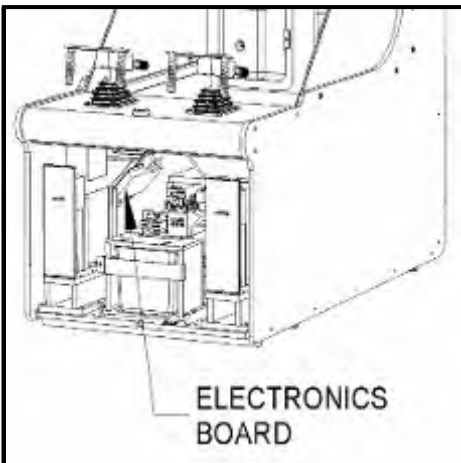

NEW LIGHTING - The game uses florescent lighting throughout greatly extending the time between bulb changes to years rather than months.

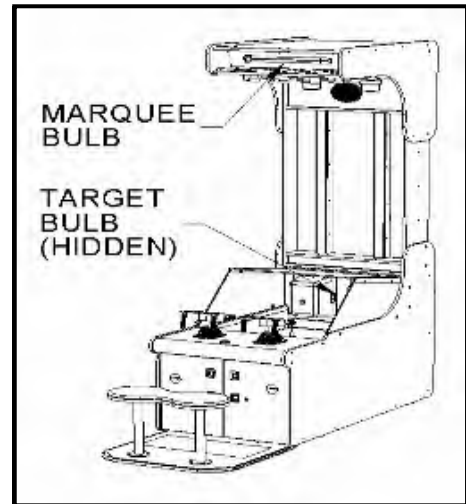

NEW SCORE SENSORS - The game utilizes fully encapsulated magnetic switches for the score sensing, greatly extending the reliability of the game.

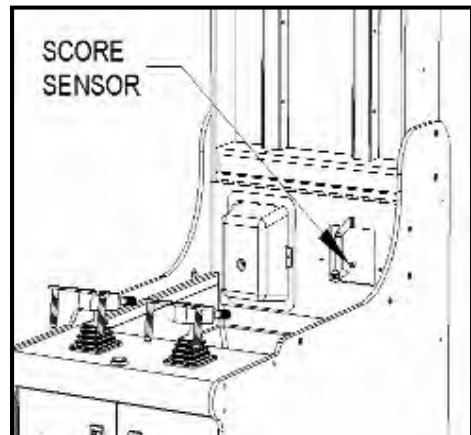

GAME PLAY

The object of the game is to shoot water from the gun into a target "pan" making the display indicator rise to the top of the game to win.

The game can be played by 1 or 2 players. The game is designed to be played in a traditional player versus player RACE or as a SINGLE player game if there is no one available to compete with.

When the game is idle, it will normally say INSERT COIN(S) on each display. Unless it is playing the attract mode.

When a player puts enough money into the game to start, the display on his side will say "GET READY" and the other side will still say INSERT COIN(S). Under the side with get ready, a count down from 15-0 will be visible.

Once both players have inserted enough money to play, the count down will continue and the game will start when the timer runs out OR as soon as the start button is pushed. If one player has started a game and a second player walks up to play and inserts money, the display on his side will flash "WAIT" until the game in progress has ended. At that time, the previous game play scenario will begin.

In a 2 player RACE game, the winning player will win BOTH of the WINNING share of tickets and the JUST FOR PLAYING tickets, while the loser will win only the JUST FOR PLAYING tickets.

For example:

The game is set for 3 tickets JUST FOR PLAYING and 5 tickets for WINNING.

In a single player game, the player wins 8 tickets period once he or she wins.

In a 2 player game, the winner would get the 8 tickets PLUS the 5 win tickets from the loser for a total of 13 tickets. The loser would get the 3 tickets just for playing.

At the end of the game, "WINNER" will flash on the winning side OR when ever the player gets to the top on the single player game type. The beacon light will also rotate when winner is flashing.

1-2. Important Safety Information:

IMPORTANT SAFETY INFORMATION

WARNING: Unplug the game from the AC wall receptacle when servicing this product. Failure to do so could result in serious injury to yourself or others.

Use only a GROUNDED AC receptacle. Failure to do so could result in improper operation or damage to the game and could void your warranty. If you are unsure that your AC receptacle is properly grounded, have a qualified electrician perform this check for you.

Always be sure power to the game is turned off when doing even routine maintenance. Otherwise, moving parts could activate unexpectedly causing injury.

This product is heavy, necessitated by the design. When moving this game, be sure you have adequate help. Use a suitable dolly or hand truck where practical. Use back support when needed.

Depending on the potentially hazardous degrees, the terms of **WARNING**, etc. are used. Be sure to understand the content of the displays before reading the text.



NOTE: ONLY QUALIFIED TECHNICAL PERSONNEL SHOULD WORK ON THIS GAME. FAILING TO COMPLY CAN CAUSE SEVERE INJURY.

SET UP

1. Clear out a location to place the game.
2. Remove all packaging from the game.
3. Remove the seat base from the top of the game by removing the 2 bolts holding it to the back door.

NOTE: DO NOT DISCARD THE BOLTS; YOU WILL NEED THEM TO ATTACH THE SEAT BASE TO THE GAME.

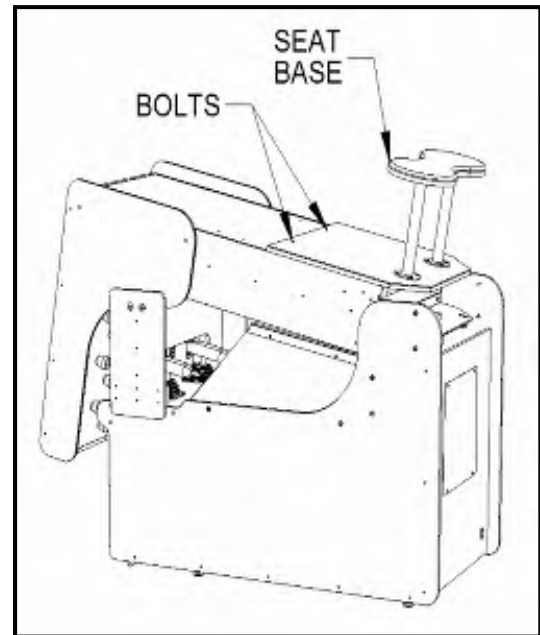

NOTE: ALTHOUGH ALMOST ALL MAINTENANCE IS DONE FROM THE FRONT OF THE GAME, WE WOULD RECOMMEND PLACING THE GAME AT LEAST 12" FROM THE WALL IN CASE IT IS NECESSARY TO ACCESS THE REAR PANELS.

WARNING: TO AVOID INJURY TO YOURSELF OR OTHERS, WE RECOMMEND THAT YOU HAVE AT LEAST 2 PEOPLE HELP TO SUPPORT THE REAR OF THE GAME WHILE CONNECTING THE FASTENERS.

4. Place the game in its final location and slowly raise the game into its upright position.

5. While 2 people hold the game vertically, open the coin door using the keys taped inside the return slot.
6. Remove the cash box to retrieve the connecting bolts and power cord.

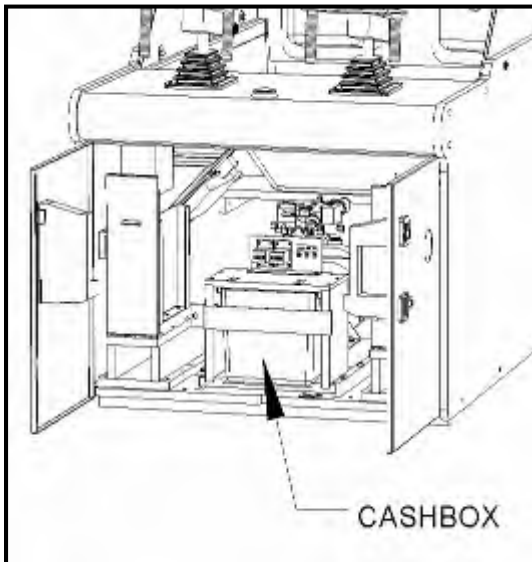

7. Push the upper cabinet fully back and secure the upper cabinet with the (4) mounting bolts and washers supplied.

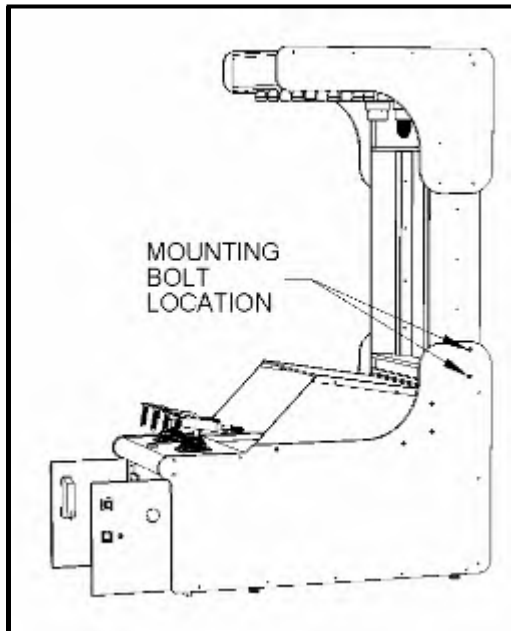

8. Close the doors to be sure they line up evenly and close securely. If either of the doors is lower than the other, raise the mounting foot on the side of the game with the lower door until the doors close evenly.

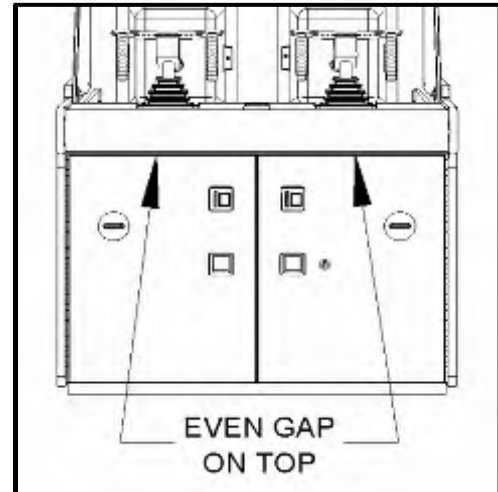

9. With the doors open, slide the seat base under the game until the holes in the base line up with the holes in the bottom of the cabinet.

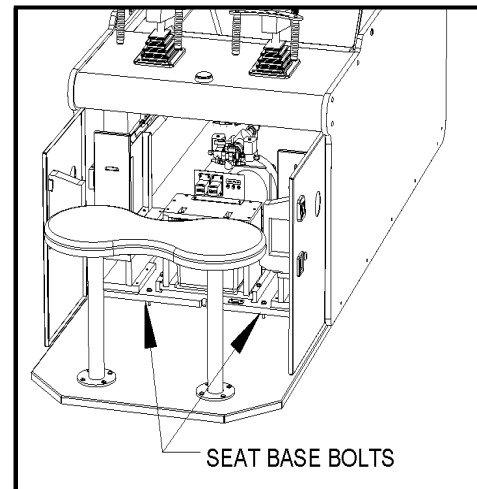

NOTE: JUST SCREW THE BOLTS INTO THE SEAT BASE ENOUGH TO HOLD IN PLACE DO NOT TIGHTEN DOWN OR THE SEAT BASE WILL LIFT UP. THIS FREE-FLOATING DESIGN ALLOWS THE SEAT BASE TO LEVEL TO THE FLOOR INDEPENDENTLY OF THE GAME.

10. Plug the game into a suitable A.C. Receptacle.
11. Turn the game on to be sure it powers up properly.
12. Remove the protective wrapping on the tank screen and set the screen into the tank.
13. Get a bucket with 5 gallons of water in it to fill the game reservoir.

NOTE: THE GAME COMES WITH AN ALCOHOL WATER MIXTURE TO PREVENT FREEZE DAMAGE WHEN SHIPPING IN COLD CLIMATES. THIS FLUID SHOULD BE WASHED OUT WHEN THE GAME IS SET-UP.

14. Fill the game tank with 5 gallons of water.

NOTE: ANY WATER CAN BE USED, HOWEVER USING DISTILLED WATER WILL KEEP YOUR GAME MUCH CLEANER AND SPOT FREE AND EXTEND YOUR WATER CHANGE INTERVALS.

15. Set the game's GAME / DRAIN valve to the drain position.

16. Press the PROGRAM button on the game's programming panel to access the programming options.

17. Press the SELECT button and advance to the DRAIN option.

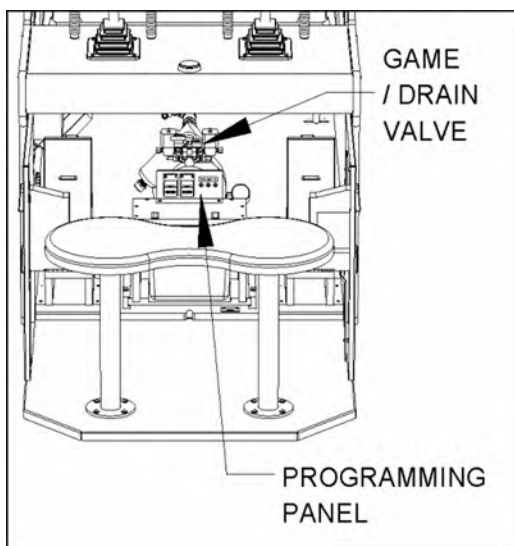

18. Press the VALUE button to turn the pump on and off.

NOTE: THE PUMP IS RUN ON A GROUND FAULT INTERRUPTER CIRCUIT. THIS IS TO PROVIDE A HIGH DEGREE OF SAFETY TO THE CUSTOMER. IF THE PUMP DOES NOT RUN WHEN THE GAME IS STARTED, CHECK THE RESET BUTTON ON THE GROUND FAULT OUTLET ON. THE RESET BUTTON MUST BE DEPRESSED DURING GAME PLAY TO BE ACTIVATED. PUSHING THE RESET BUTTON WHEN THE GAME IS OVER WILL NOT HAVE ANY EFFECT.

19. Hold the drain hose into the 5 gallon pail and press the VALUE button to start the pump.

20. Run the pump until the water comes out of the drain hose clear. TURN PUMP OFF.

21. Turn the GAME / DRAIN valve to the GAME position.

22. Start a 2 player game and check for proper operation of the guns.

NOTE: IT IS NORMAL FOR THE GUNS TO SPUTTER DURING THE FIRST GAME UNTIL ALL OF THE AIR IS PURGED FROM THE HOSES AND LINES.

23. Adjust the programming options as needed.

2. PROGRAMMING

2-1. ENTERING PROGRAMMING MODE:

The programming options are readable only by the game operator for the purpose of customizing the game to suit their location.

The operator will press the "PROGRAMMING" button once to enter the programming mode.

The operator will press the "SELECT" button to scroll through the various options that are on the left-hand display.

The operator will press the "STEP" button to scroll through the various settings for each option that are shown on the right-hand display.

The operator will press the "PROGRAMMING" button once again to EXIT the programming mode and save all of the new values to the games memory.

Below is detailed information for the operation of each of the programming options.

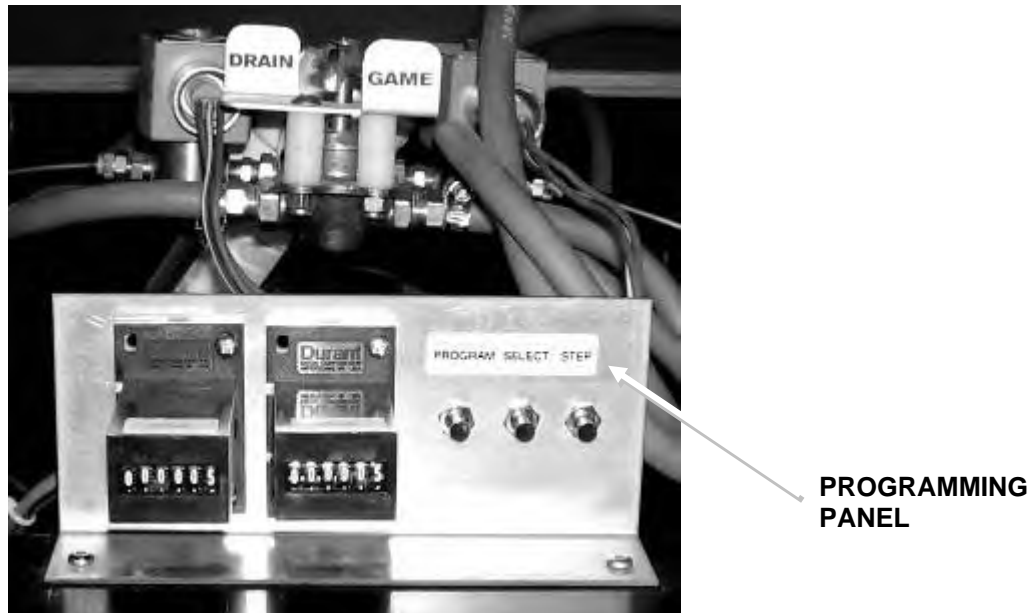

2-2. VOLUME:

This option controls the sound volume from the speaker on the front door of the game. The range for this option is 1-10 (10 being the loudest). The default value for this option is 3.

2-3. COINS PER CREDIT (COIN/CR):

This option determines how many coins are needed to earn a credit. Each credit will automatically start a game. The range for this option is 1-10; the default value for this option is 1.

NOTE: There is no "free play" option for this game. If free play is desired, set the game to 1 coin per credit and install a momentary contact push button to start the game.

2-4. ATTRACT MODE (ATTRACT):

This option determines how often the attract sounds or (player taunting) will be heard from the game. The range for this option is 0-5 (minutes). Setting a 0 shuts the attract mode off. The default value for this option is 5.

2-5. JUST FOR PLAYING TICKETS:

This option determines how many tickets the player gets just for playing the game. The range for this option is 0-10. The default value for this option is "3".

2-6. WINNER TICKETS:

This option determines how many tickets the player gets for winning the game. The range for this option is 0-10. The default value for this option is "5".

2-7. GAME TIME TO WIN:

This option determines how many seconds it takes to win the game when the target is kept depressed. The range for this option is 5-20 seconds. The default value for this option is "12".

2-8. TIME OUT:

This option determines how many seconds of inactivity (target not depressed) are necessary for the game to automatically end. The range for this option is 0, 10 or 20 seconds. Setting a "0" disables the auto end function. The default value for this option is "10". NOTE: If the game auto ends, the JUST FOR PLAYING tickets ONLY will be dispensed and there are no "winners".

2-9. DRAIN WATER:

This option is used as a convenient way to run the pump when setting up, changing water, or draining the game. Pressing the VALUE button will turn the pump on or off.

2-10. MONEY:

This option determines whether the board is set up for Coin Play or for a Card Swipe. The options for this setting are 0 or 1. 0 sets the game up for Coin Play, while 1 sets the game up for a Card Swipe. "0" is the factory default for the Money option.

2-11. RESET: *(Default programming value - reset)*

This option will reset the game to factory default values. The range for this option is 0-1. Setting a "1" will reset the values to factory default. The default value for this option is "0".

2-12. PROGRAMMING OPTIONS:

REGISTER	Min/Max	BSR	DESCRIPTION
Volume	1-10	3	Volume Control
Coins/Credit	1-10	1	Number of Coins per Game
Attract Mode	1-5	3	Minutes Between Bally Music
Default Tickets	0-10	3	Tickets Just for Playing
Winner Tickets	0-30	5	Winning Tickets Per game
Time to Win	5-20	12	Time to Win in Seconds
Time Out	0,10,20	10	Time of Inactivity/Auto Win
Money	0,1	0	Coin play (0) or card swipe play (1)
Drain Water	0-1	On/Off	Pump ON/OFF (Manual)
Reset Defaults	0-1	0	Reset Factory Default Settings

3. MAINTENANCE AND TROUBLESHOOTING

3-1. Quick Troubleshooting:



WARNING

For your safety and to reduce risk of damage to your game read the Important Safety Information in Chapter 1-2 before attempting any troubleshooting procedure.

TROUBLESHOOTING PHILOSOPHY

When troubleshooting any product, certain general guidelines should be followed.

1. Always check to be sure that your game is turned on. Be sure that all of the fuses in the game are functional and check to see that the AC voltage is in the proper operating range for your game.
2. Check to be sure that all of the game harnessing is plugged in properly and that all of the pins are firmly seated in the connectors. It is always possible that a harness can be damaged by rough shipping or moving.
3. Check game harnessing to be sure that none of the wires have become damaged. Using a handheld multi-meter, check continuity of the wires to make sure they are not broken.
4. Check for obvious damage to any P.C. Boards or electrical components.
5. If you have multiple games or multiple parts on a game, change or exchange the parts and see if the problem goes away or moves to another location. This way you can quickly eliminate certain parts as being the problem with the game.
6. When changing electronic or electrical components, ALWAYS turn off and unplug the game.
7. Check to see that all power supplies are delivering the specified voltages to the P.C. Boards and components as shown in the manual.

For detailed servicing and repair information see the full the full repair section of this manual.

Symptom	Possible Problem	Solution
	Power	Power
Sound Problems -No sound -Low Sound -Intermittent Sound	Low Volume Faulty speaker harnessing Faulty speaker Faulty sound board or sound board harnessing Faulty Main P.C. Board	Check Volume Control and adjust as necessary Check connections and/or repair harnessing Check and/or replace speaker Check connections or Replace Sound Board Check and/or repair or replace Main P.C. Board
Game does not take or add money correctly	Coin switch out of adjustment Coin mech dirty or improperly adjusted Faulty Coin switch Faulty coin switch harness or connector Improperly programmed electronic mech Game improperly programmed Faulty Front Panel Board Faulty Main P.C. Board or component	Re-bend coin switch wire Clean and adjust mech as necessary Check and/or replace switch Check and/or repair harnessing Reprogram or replace electronic mech Check programming options and adjust Repair and/or replace Front Panel Board Repair and/or replace Main P.C. board
Ticket Dispenser not working properly, or no tickets being dispensed	No tickets in the game Tickets jammed in dispenser Ticket dispenser sensor blocked with debris Poor connection on the ticket dispenser Game improperly programmed Faulty ticket dispenser Faulty ticket dispenser harnessing Repair and/or replace Front Panel Board Faulty Main P.C. Board	Refill ticket dispenser and press the reset button Clear ticket jam Clean off sensor Check and/or replace connectors Check ticket programming options Replace dispenser Check and/or repair harnessing Faulty Front Panel Board Replace or repair Main P.C. Board
Game will not start or pump will not run	Game power off Main fuse blown Ground wire broken or loose Faulty coin switch GFI circuit tripped Faulty pump Power Supply problem or failure Faulty P.C. board or component	Check on/off switch and power cord Check and/or replace fuse as necessary Replace or tighten faulty ground wire Check coin switch Start game and push GFI reset button Check and replace pump Check Power Supply output and connections Repair and/or replace main P.C. board
Game stops or is stopped with nothing displayed	The power connector is disconnected. Possible faulty connection or short circuit.	Reconnect the connector securely. Check all circuitry for faulty connections or short circuits.
Water stream crooked or weak	Clogged gun nozzle Partially clogged filter Kinked hose Low water level or no water	Check and clean gun nozzle Check filter and clean if necessary Check all hoses Check water level and fill if necessary
Display lights won't move	Faulty target switch Faulty or disconnected harness Faulty Main P.C. board	Check target switch Check and repair harnessing Repair or replace main P.C. board
Water not coming out of gun	Clogged gun nozzle Kinked hose Low water level or no water Faulty solenoid valve GFI circuit tripped Faulty Pump Faulty Main P.C. board	Clean nozzle with paper clip Check hoses for kinks Check water level and fill if necessary Check or replace solenoid valve Start game and push GFI reset button Repair or replace pump Repair or replace Main P.C. Board
Programming button and counters	Disconnected programming Panel harness	Check connector Check connector

3-2. Maintenance:

Daily Maintenance:

1. TURN ON GAME POWER SWITCH
2. PHYSICALLY CHECK WATER LEVEL IN WATER TANK. IF THE WATER IS LOW OR BELOW THE FILL LINE FILL THE TANK. MAKE SURE THERE IS A MINIMUM OF 5 GALLONS IN THE TANK AT ALL TIMES AND THE WATER IS ABOVE THE FILL LINE. *FOR INSTUCTIONS ON HOW TO FILL THE TANK SEE THE "FILLING THE WATER TANK" SECTION.*
3. CHECK TICKET LEVELS IN TICKET DISPENCERS BEFORE OPENING EACH DAY
4. CLEAN, WIPE DOWN, AND DRY OFF GAME NIGHTLY OR AS NEEDED
5. CHECK ALL LIGHT BULBS FOR WORKING ORDER (THIS INCLUDES TARGET PAN LIGHTS)
6. IT IS RECOMMENDED THAT YOU CLEAN THE WATER FILTER EVERY THREE DAYS OR AS NEEDED DEPENDING ON WATER CONDITIONS.

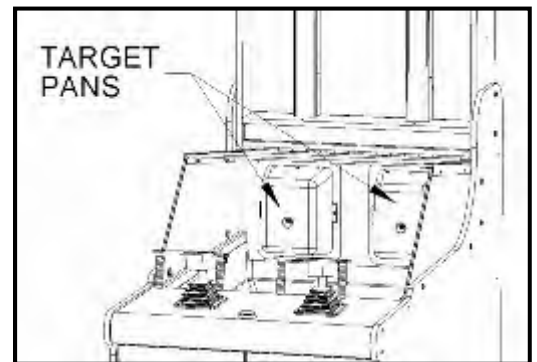

Weekly Maintenance:

1. CHECK THE WATER SYSTEM FOR DIRT AND DEBRIS.
2. IT IS RECOMMENDED THAT YOU CHANGE THE WATER SUPPLY ONCE A WEEK OR AS NEEDED DEPENDING ON WATER CONDITION. REMEMBER TO REMOVE THE FILTER CANISTER AND CLEAN SCREEN EACH TIME WATER IS CHANGED. *FOR INSTUCTIONS ON HOW TO EMPTY OR DRAIN THE WATER SEE THE "CHANGING THE WATER" SECTION.*
3. CHECK PLUMBING SYSTEM FOR LEAKS OR PLUMBING ISSUES.

Miscellaneous Maintenance:

1. CLEAN GUN TIPS OF ANY DEBRIS
NOTE: IF THE WATER GUNS ARE NOT SHOOTING STRONG OR STRAIGHT CLEAN THE GUN TIP. FOR INSTUCTIONS ON HOW TO CLEAN THE GUN PARTS SEE THE "CLEAN GUN PARTS" SECTION.

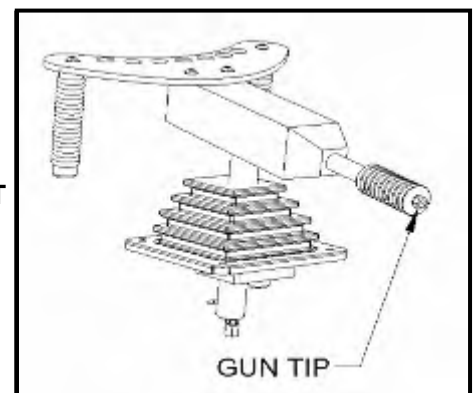

REMOVE TIP AND CLEAN WHEN ONE DOES NOT SHOOT WATER.

3-3. Detailed Troubleshooting and Repair:

3-3-1. Changing the Water:

1. Set the game's GAME / DRAIN valve to the drain position.
2. Press the PROGRAM button on the game's programming panel to access the programming options.
3. Press the; SELECT button and advance to the DRAIN option.
4. Press the VALUE button to turn the pump on and off.

NOTE: THE PUMP IS RUN ON A GROUND FAULT INTERRUPTER CIRCUIT. THIS IS TO PROVIDE A HIGH DEGREE OF SAFETY TO THE CUSTOMER. IF THE PUMP DOESN'T RUN WHEN THE GAME IS STARTED, CHECK THE RESET BUTTON ON THE GROUND FAULT OUTLET ON. THE RESET BUTTON MUST BE DEPRESSED DURING GAME PLAY TO BE ACTIVATED. PUSHING THE RESET BUTTON WHEN THE GAME IS OVER WILL NOT HAVE ANY EFFECT.

5. Hold the drain hose into the 5 gallon pail and press the VALUE button to start the pump.
6. Run the pump until ALL of the water empties out of the tank. Turn off the pump
7. Turn the GAME / DRAIN valve to the GAME position.
8. Remove the screen at the bottom of the tank and clean both the tank and the screen. Re-install the screen.
9. Add 5 gallons of water to a bucket and add 1 TBSP Cascade Dishwashing powder. (This will help keep the glass clean). DO NOT use too much Cascade or foaming will result.

SUGGESTION: ALTHOUGH ANY WATER CAN BE USED, USE DISTILLED WATER WHENEVER POSSIBLE. DISTILLED WATER HAS ALL OF THE MINERALS REMOVED AND WILL DRASTICALLY EXTEND THE TIME INTERVAL BETWEEN WATER CHANGES.

10. Clean the inside of the glass with a plastic scrub pad to remove dirt and sediment from the glass.

NOTE: IF THE GLASS IS BADLY STAINED, USE C.L.R. MINERAL REMOVAL SPRAY FIRST TO GET RID OF TOUGH MINERAL DEPOSITS.

11. Spray RAIN-X on the inside of the glass to help prevent minerals from forming on the glass.
12. Fill the tank with the 5 gallons of water.
13. Set the game's GAME / DRAIN valve to the DRAIN position.
14. Press the PROGRAM button on the game's programming panel to access the programming options.
15. Press the SELECT button and advance to the DRAIN option.
16. Press the VALUE button to turn the pump on and off.
17. Hold the drain hose into the 5 gallon pail and press the VALUE button to start the pump.
18. Run the pump until the water comes out.
19. Turn the GAME / DRAIN valve to the GAME position; put 5 gallons of fresh water in game.

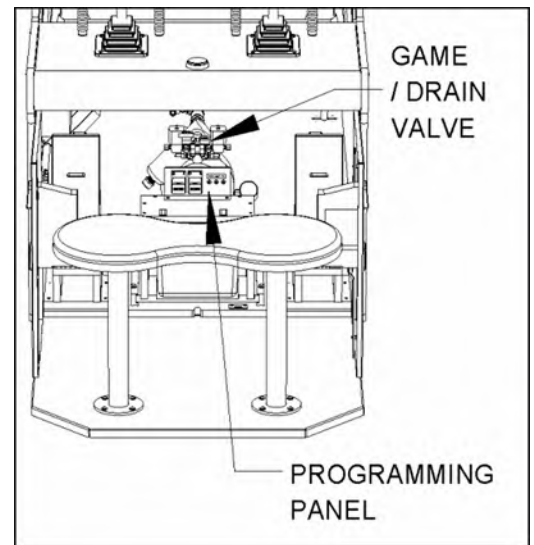

WARNING: BEFORE SLIDING PUMP INTO PLACE, PLAY THE GAME, CHECKING FOR WATER LEAKS, AS THIS WILL CAUSE SEVER DAMAGE TO GAME.

3-3-2. Glass Cleaning:

1. Clean the inside of the glass with a plastic scrub pad to remove dirt and sediment from the glass. DO NOT use any steel wool or scotch bright pads as these will damage the plastic side glass panels.

NOTE: IF THE GLASS IS BADLY STAINED, USE C.L.R. MINERAL REMOVAL. SPRAY FIRST TO GET RID OF TOUGH MINERAL DESPOSITS.

2. Spray RAIN-X on the inside of the glass to help prevent minerals from forming on the glass.

3. Clean the outside of the glass with any good commercial glass cleaner.

3-3-3. Draining the Water:

1. Set the game's GAME / DRAIN valve to the drain position.

2. Press the PROGRAM button on the game's programming panel to access the programming options.

3. Press the SELECT button and advance to the DRAIN option.

4. Press the VALUE button to turn the pump on and off.

NOTE: THE PUMP IS RUN ON A GROUND FAULT INTERRUPTER CIRCUIT. THIS IS TO PROVIDE A HIGH DEGREE OF SAFETY TO THE CUSTOMER. IF THE PUMP DOES NOT RUN WHEN THE GAME IS STARTED, CHECK THE RESET BUTTON ON THE GROUND FAULT OUTLET ON. THE RESET BUTTON MUST BE DEPRESSED DURING GAME PLAY TO BE ACTIVATED. PUSHING THE RESET BUTTON WHEN THE GAME IS OVER WILL NOT HAVE ANY EFFECT.

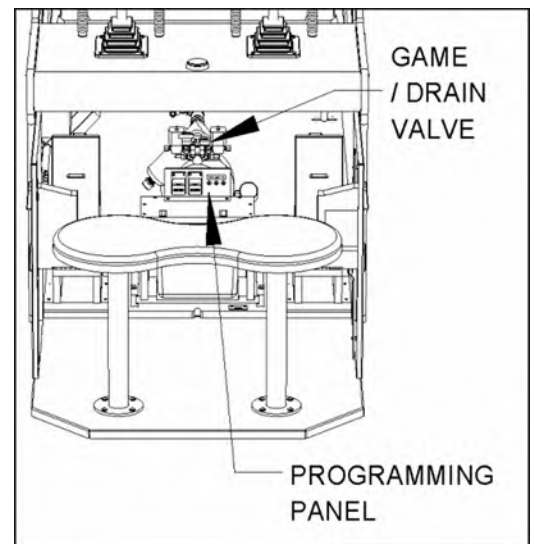

5. Hold the drain hose into the 5 gallon pail and press the VALUE button to start the pump.

6. Run the pump until ALL of the water empties out of the tank. Turn off the pump.

7. Turn the GAME / DRAIN valve to the GAME position.

8. Remove the screen at the bottom of the tank and clean both the tank and the screen. Re-install the screen.

3-3-4. Filling the Water Tank:

1. Add 5 gallons of water to a bucket and add 1 TBSP. Cascade Dishwashing powder. (This will help keep the glass clean). DO NOT use too much Cascade or foaming will result.

SUGGESTION: ALTHOUGH ANY WATER CAN BE USED, USE DISTILLED WATER WHENEVER POSSIBLE. DISTILLED WATER HAS ALL OF THE MINERALS REMOVED AND WILL DRASTICALLY EXTEND THE TIME INTERVAL BETWEEN WATER CHANGES.

2. Clean the inside of the glass with a plastic scrub pad to remove dirt and sediment from the glass.

NOTE: IF THE GLASS IS BADLY STAINED, USE C.L.R. MINERAL REMOVAL SPRAY FIRST TO GET RID OF TOUGH MINERAL DEPOSITS.

3. Spray RAIN-X on the inside of the glass to help prevent minerals from forming on the glass.
4. Fill the tank with the 5 gallons of water.
5. Set the game's GAME / DRAIN valve to the drain position.
6. Press the PROGRAM button on the game's programming panel to access the programming options.
7. Press the SELECT button and advance to the DRAIN option.
8. Press the VALUE button to turn the pump on and off.
9. Hold the drain hose into the 5 gallon pail and press the VALUE button to start the pump.
10. Run the pump until the water comes out.
11. Turn the GAME / DRAIN valve to the GAME position.
12. Play a couple of 2 player games to remove all of the air from the system.

3-3-5. Water Pump Removal:

1. DRAIN TANK AS DIRECTED ABOVE.
2. Open the front doors of the game and remove the bolts that hold the seat base to the game. (See image to the right)
3. Move the seat assembly out of the way.
4. Remove the cash box and remove the single bolt located in the bottom of the cash box enclosure. (See image below)

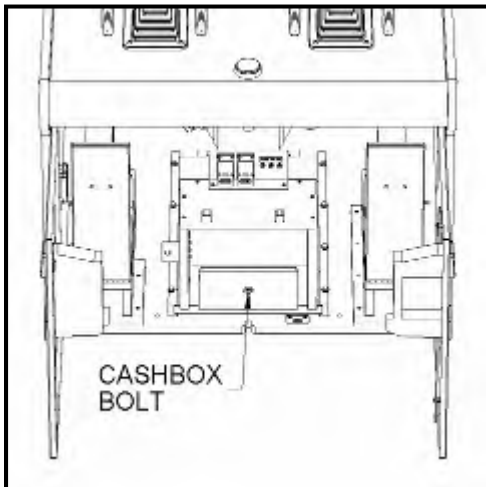
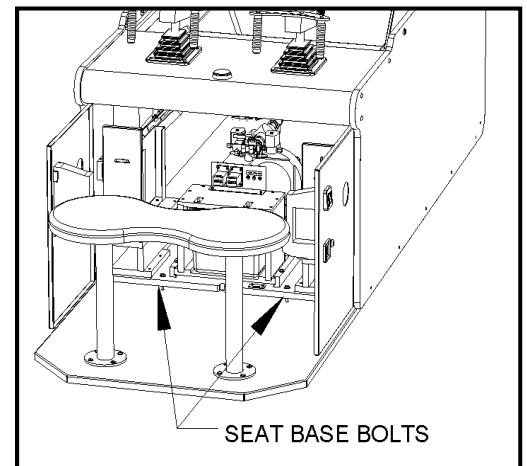

5. Slide the cash box enclosure out of the game and unplug the programming panel connector. Set the cash box enclosure to the side.
6. Carefully slide the pump assembly forward to access the pump. (See image below)

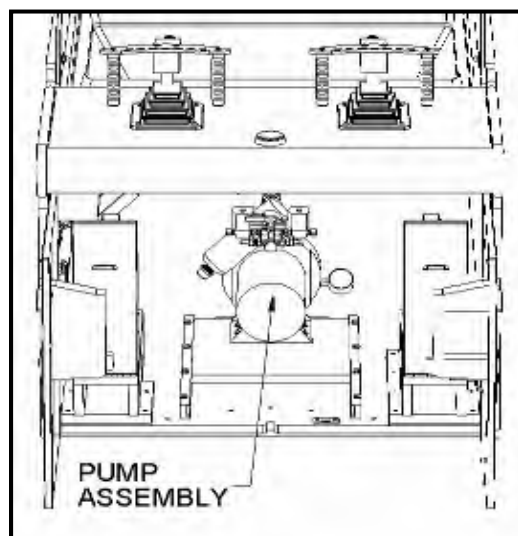

7. Unplug the solenoid harnesses and the A.C. Motor plug from the outlet in the upper left hand side of the cabinet.
(See image to the right)

NOTE: SERVICING OF THE SOLENOID VALVES CAN BE COMPLETED AT THIS STAGE OF REMOVAL. FOR FURTHER SERVICE, CONTINUE TO REMOVE THE PUMP ASSEMBLY.

HAVE A SPONGE OR TOWEL AND SMALL BUCKET HANDY TO CATCH ANY DRIPS FROM THE HOSES.

8. Unscrew the small black hoses from the guns at the solenoids.
Wipe up any drips from the hoses.

9. Carefully pull the pump unit out of the game.

10. With a sharp knife, cut the large feed hose and small return hose as close to the pump fittings as possible.

IT IS NECESSARY TO CUT THE HOSES OFF, AS IT IS TOO DIFFICULT TO TRY TO PULL THEM OFF OF THE FITTINGS.

11. Remove the hose clamps and cut the remaining pieces of hose from the pump fittings

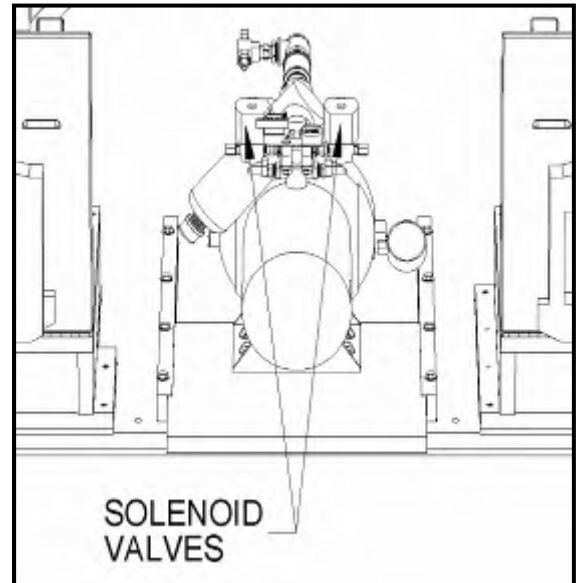

THE PUMP ASSEMBLY CAN NOW BE SERVICED OR REPLACED.

REPLACE ANY NECESSARY COMPONENTS MAKING SURE THAT ALL FITTINGS ARE SEALED WITH TEFLON TAPE.

3-3-6. Water Pump Installation:

1. Connect the feed and return hoses to the pump assembly. Leave the hose clamps loose at this time.

2. Slide the pump assembly back into the unit until it hits the rear stop.

3. Adjust the hoses to be sure that there are no kinks at all in the hoses.
If there are any kinks, rotating the hoses will usually remove them.

4. TIGHTEN THE HOSE CLAMPS.

5. Reconnect the A.C. plug making sure that it is routed out of the way
(behind ticket bin).

6. Re-install the solenoid harnesses by plugging in the connectors.

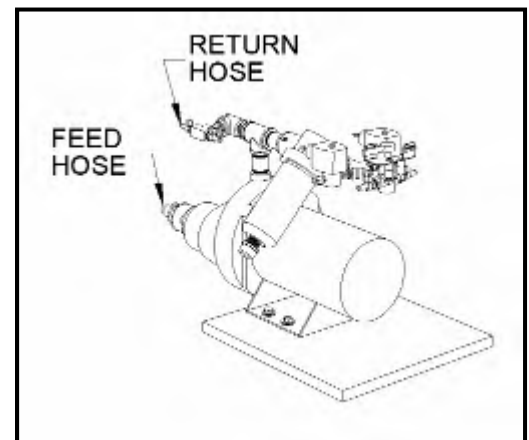

NOTE: THE HARNESS MARKED "161" GOES TO THE LEFT HAND SIDE AND THE HARNESS MARKED "162" GOES TO THE RIGHT HAND SIDE.

7. Re-install the cash box enclosure and reconnect the programming panel harness by plugging in the connector.

8. Re-install the small black hoses from the solenoid valves to the guns.

9. FILL THE WATER TANK AS DIRECTED ABOVE.

10. Re-install the cash box and bolt.

11. Re-install the seat assembly and bolts.

3-3-7. Cleaning Gun Parts:

It is possible after extended periods of time, or if the water you use is very high in mineral content that you may have to clean deposits or debris from the gun assembly.

1. To clean the gun tip, try cleaning with a paper clip first. If that doesn't work, unscrew the tip to clean. (See image to the right)
2. For larger debris, unscrew the gun assembly from the top of the control panel. Disconnect the spring from underneath. (See image below)

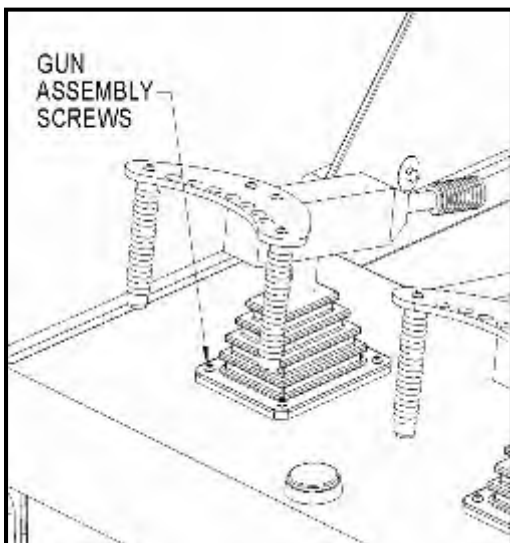
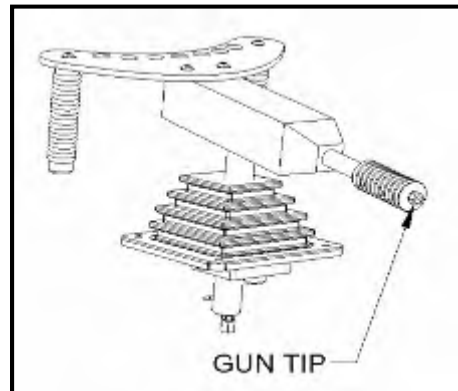

3. Remove the hose and nozzle tip from the gun.
4. Run a coat hanger or thick wire through the gun passages to remove any blockage.
5. With the tip off the gun, re-install the gun and connect the hose.
6. Play a few games to allow any debris to escape the gun body.
7. Re-install the gun tip and check for proper operation.

3-3-8. Target Sensors:

1. Remove the lower rear access door. (See image to the right)
2. Unscrew the target pans from the game. (See image below)

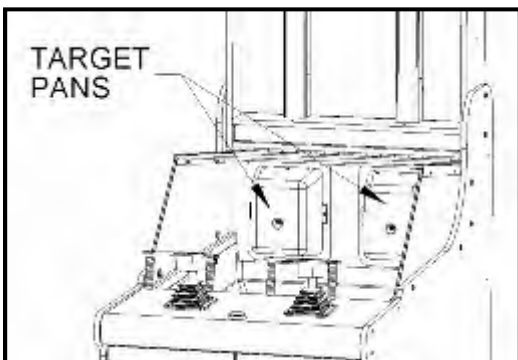
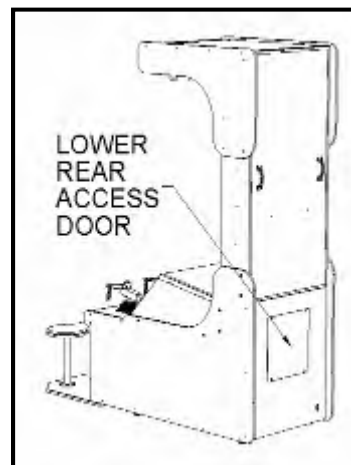

3. Unscrew the magnetic sensor from the clear polycarbonate window. (See image to the right)
4. Unplug the sensor.

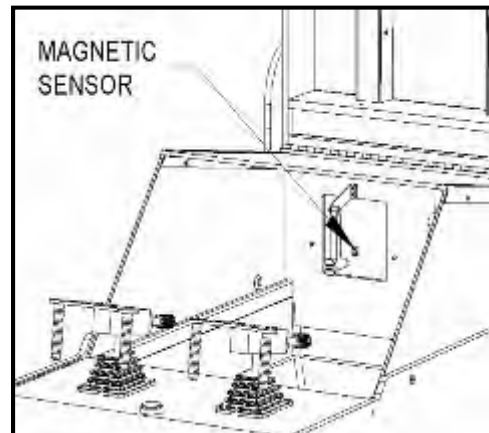

5. Re-install the new sensor using the other sensor as a guide to proper positioning. (See image to the right)
6. Check for proper alignment between the magnetic sensor and the magnet that is located on the target arm.
7. Re-install the target pan.
8. Play a couple of games to check for proper operation.
9. Re-install the lower rear access door.

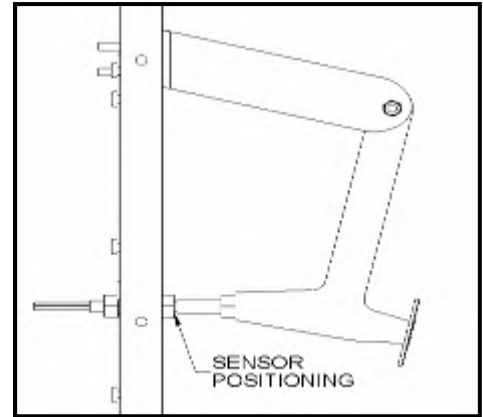

3-3-9. Main P.C. Board Removal and Installation:

ALTHOUGH THE MAIN P.C. BOARD CAN BE REMOVED THROUGH THE FRONT DOOR WITH THE SEAT AND CASH BOX ENCLOSURE IN PLACE, IT IS MUCH EASIER TO DO SO IF THEY ARE REMOVED FIRST. TO REMOVE THEM FOLLOW THE INSTRUCTIONS BELOW.

WARNING: BE SURE TO UNPLUG THE GAME BEFORE SERVICING TO AVOID SERIOUS INJURY OR DAMAGE TO THE GAME.

1. Open the front doors of the game and remove the bolts that hold the seat base to the game.
2. Move the seat assembly out of the way.
3. Remove the cash box and remove the single bolt located in the bottom of the cash box enclosure.
4. Slide the cash box enclosure out of the game and unplug the programming panel connector. Set the cash box enclosure to the side.
5. Unplug all of the connectors from the Main P.C. Board.
(See image to the right)

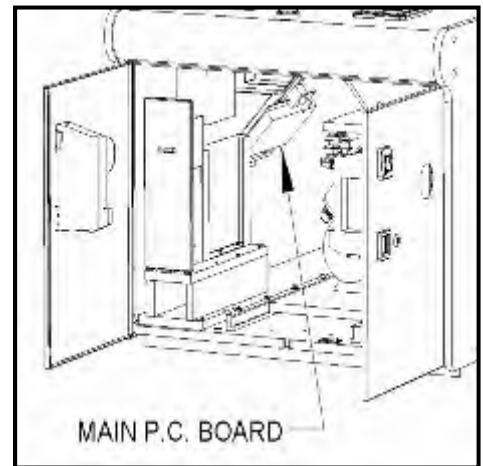

6. Unscrew the retaining clamp on the board mounting bracket and remove the board.
7. Install a new P.C. Board, making sure that the board engages the slots on the bottom of the mounting bracket.
8. Tighten the P.C. Board retaining clamp.

NOTE: BE SURE THE CLAMP IS NOT CONTACTING ANY COMPONENTS ON THE BOARD OR SERIOUS DAMAGE MAY RESULT.

9. Re-install all of the connectors. Be sure they are inserted properly and that all of the connector locks are snapped into place.
10. Re-install the cash box.
11. Re-install the seat assembly.

3-3-10. Display P.C. Board Removal and Installation:

ALTHOUGH THE CONNECTORS FOR THE DISPLAY P.C. BOARD CAN BE REMOVED THROUGH THE FRONT DOOR WITH THE SEAT AND CASH BOX ENCLOSURE IN PLACE, IT IS MUCH EASIER TO DO SO IF THEY ARE REMOVED FIRST. TO REMOVE THEM FOLLOW THE INSTRUCTIONS BELOW.

WARNING: BE SURE TO UNPLUG THE GAME BEFORE SERVICING TO AVOID SERIOUS INJURY OR DAMAGE TO THE GAME.

1. Open the front doors of the game and remove the bolt that holds the seat base to the game.
2. Move the seat assembly out of the way.
3. Remove the cash box and remove the single bolt located in the bottom of the cash box enclosure. (See image to the right)
4. Slide the cash box enclosure out of the game and unplug the programming panel connector. Set the cash box enclosure to the side.
5. Unplug the Appropriate harness from the Main P.C. Board. If it is the left hand display, unplug connector **P6** from the Main board. If it is the Right hand display, unplug **P7**.

NOTE: WHEN DISCONNECTING THE RIGHT HAND DISPLAY CONNECTOR (P7), BE SURE TO UNPLUG THE SINGLE WIRE FAST-ON CONNECTOR THAT IS RIGHT AT THE CONNECTOR AS WELL.

6. Remove the upper and lower rear access panels to be able to access the display harnessing. (See image to the right)

NOTE: THE DISPLAY HOUSING AND HARNESSING ARE REMOVED AND INSTALLED AS A SUB-ASSEMBLY.

7. Pull the display harness to the rear of the game and up through the cabinet holes.
8. Unbolt the display housing from the rear of the cabinet and pull straight out of the game.
9. Assemble in reverse order.

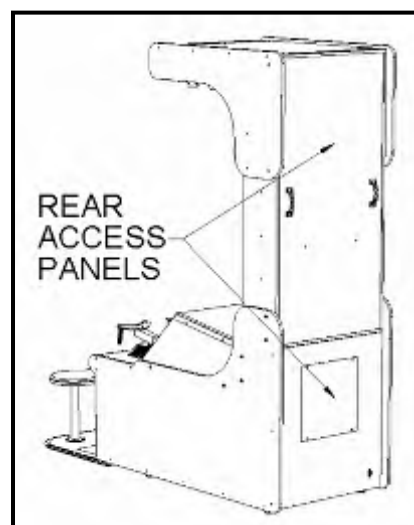
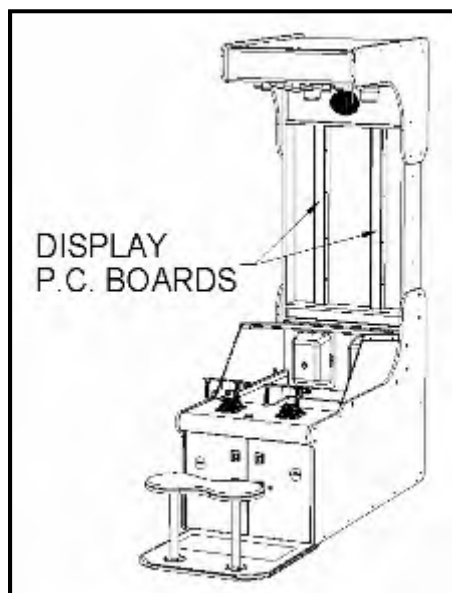

3-3-11. Display P.C. Board Servicing

1. Slide the display filter out of the housing.
2. Remove the 8 bolts that hold the Display mounting bracket to the Display housing. (See image to the right)
3. Slide the mounting bracket out of the housing.
4. Remove the connectors and defective display P.C. Board.
5. Assemble in reverse order.

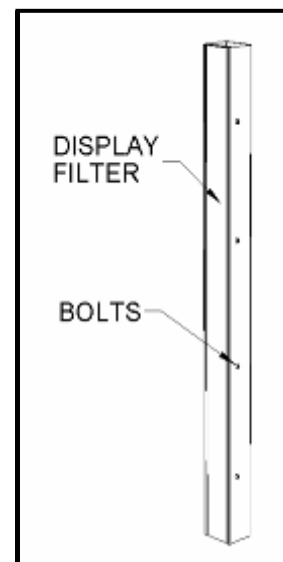

4. PARTS LISTING

MECHANICAL PARTS		ELECTRONIC / ELECTRICAL PARTS	
ARWB1003	TANK WATER STRAINER	ARWB2001	MAIN P.C. BOARD
ARWB1017	GUN BODY	ARWB2002	MAGNETIC TARGET SENSOR
ARWB1018	GUN HANDLE MOUNT	ARWB2003	TARGET MAGNET
ARWB1019	WATER GUN HANDLE	ARWB2004	MARQUEE LIGHT FLASHER
ARWB1020	GUN MOUNTING PLATE	UNIT	
ARWB1021	GUN BOOT BEZEL (STAINLESS)	ARWB6001	1/2 HP PUMP ONLY
ARWB1022	CASH BOX HASP	E0025100	12 VOLT COUNTER
ARWB1025	TARGET MOUNTING BRACKET	E0027150	10 FT. POWER CORD
ARWB1026	OUTER LEFT SIDE GLASS MTG BKT	COMPSTYLE	
ARWB1027	OUTER RIGHT SIDE GLASS MTG. BKT.	E0028300	TURBO BULB (FLASHING LIGHTS)
ARWB1029	INSIDE GLASS MOUNTING BRACKET	E0030630	BEACON LIGHT BASE
ARWB3001	WATER GUN SWIVEL BLOCK	E0030632	BEACON LIGHT CHROME RING
ARWB3011	BENCH SEAT TOP	E0030635-RED	BEACON LIGHT RED DOME
ARWB3016	TARGET PIVOT SWING	E0070012-CLR	LENS BODY (FLASHING LIGHTS)
ARWB3017	TARGET DISK	E0070015-CL	CLEAR LENS CAP
ARWB3020	SIDE WINDOW GLASS (SAR ACRYLIC)	E0070016-BL	BLUE LENS CAP DOT
ARWB3021	TOP GLASS (TEMPERED)	E0070016-RED	RED LENS CAP DOT
ARWB6002	PRESSURE GAUGE	E0070016-YE	YELLOW LENS CAP DOT
ARWB6017	BULKHEAD (WATER PAN) DRAIN	E0800040	WORKHORSE 6 BALLAST
ARWB9004	FULL PUMP ASSEMBLY	E0800041	PL40 FLORESCENT BULB
ARWB9013	FLASHER BULB PANEL COMPLETE	E0800044	BULB RETAINING CLIP
CX800085	DISPLAY FILTER (SMOKED GREY)	E0800070	6" X 9" SPEAKER
M0006905	GUN CENTERING SPRING	E0800157	DISPLAY P.C. BOARD
M0800035	CASH BOX	E0800201	200 WATT POWER SUPPLY
M0800204	DELTRONICS 1275 TKT DISPENSER	E0800310	SOLID STATE RELAY
MX006103	GUN BARREL TIP	EX800150	P.C. BOARD HOLDER
MX006330	GUN BARREL	E0023880	FUSE, 15 AMPS SLO-BLO
MX007203	PAINTED TARGET PAN ASSEMBLY		
	GRAPHICS / DECALS		
ARWB7001	SERVICE MANUAL		
ARWB7010	CABINET RIGHT SIDE DECAL SET		
ARWB7011	CABINET LEFT SIDE DECAL SET		
ARWB7012	CONTROL PANEL DECAL		
ARWB7013	MARQUEE DECAL		
ARWB7014	TICKET DISPENSER PLAYER 1 DECAL		
ARWB7015	DISPLAY MIRROR DECAL		
ARWB7016	TICKET DISPENSER PLAYER 2 DECAL		
ARWB7017	LEVER DECAL "DRAIN"		
ARWB7018	LEVER DECAL "GAME"		

Board Schematic #1

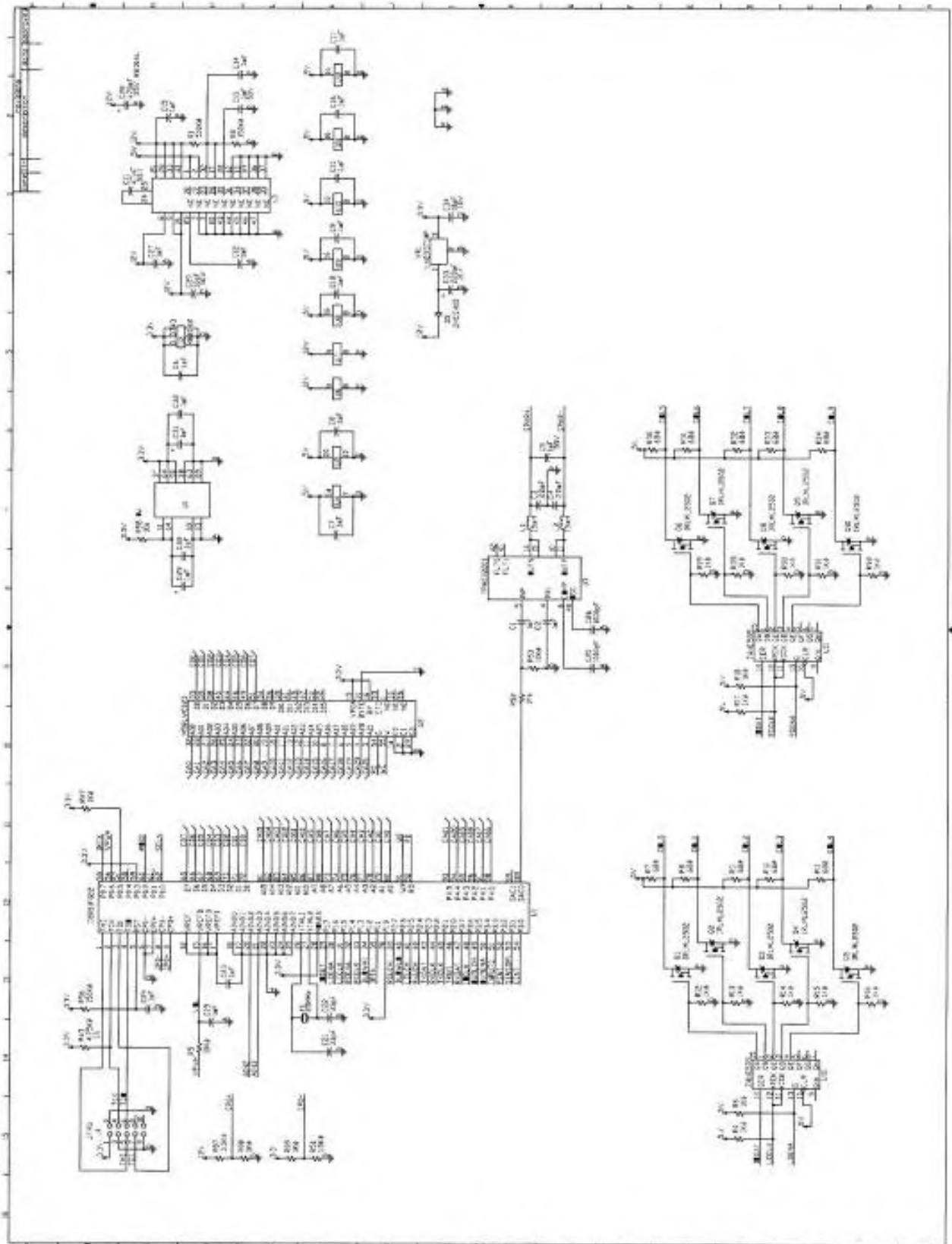

Board Schematic #2

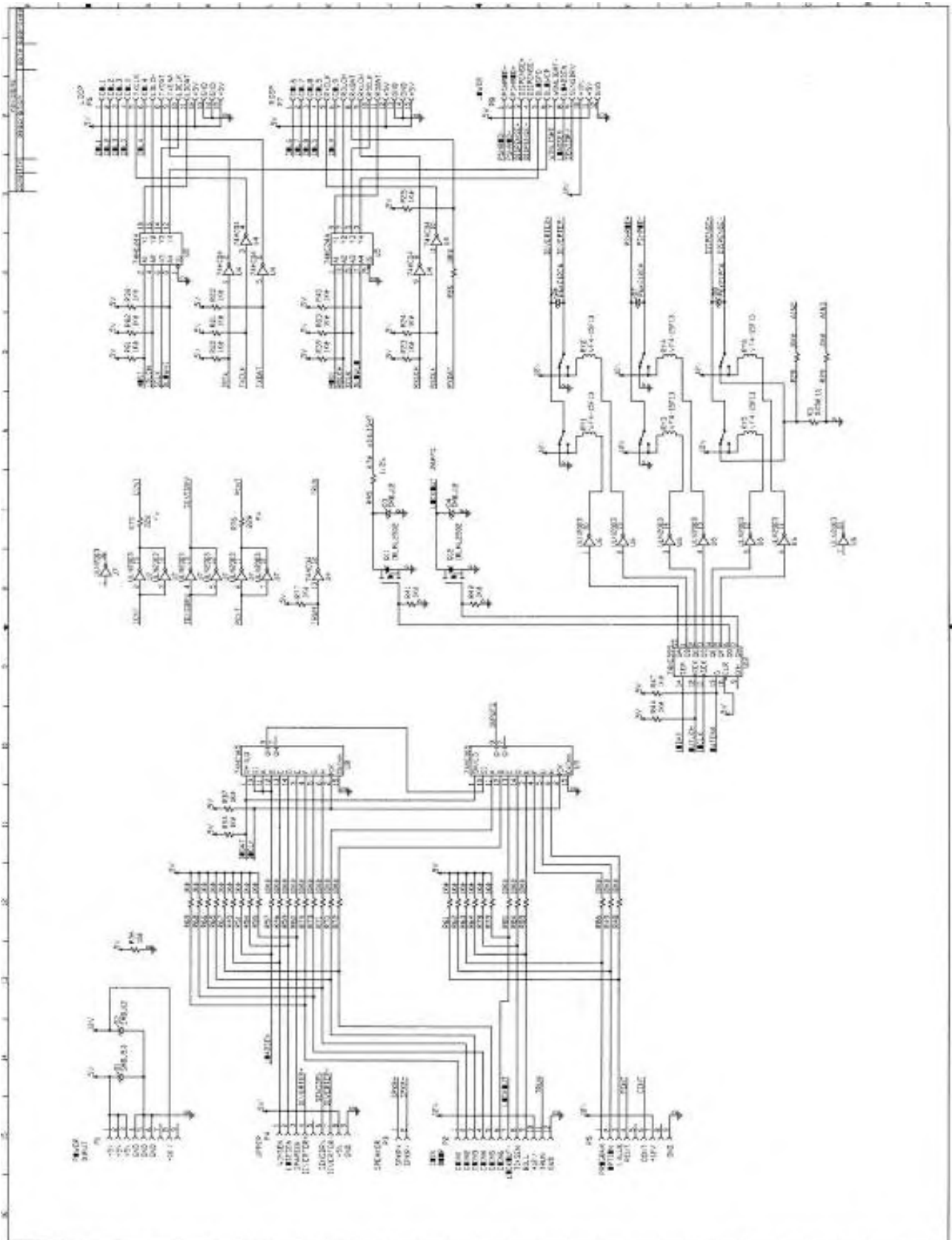

LED Display Schematic

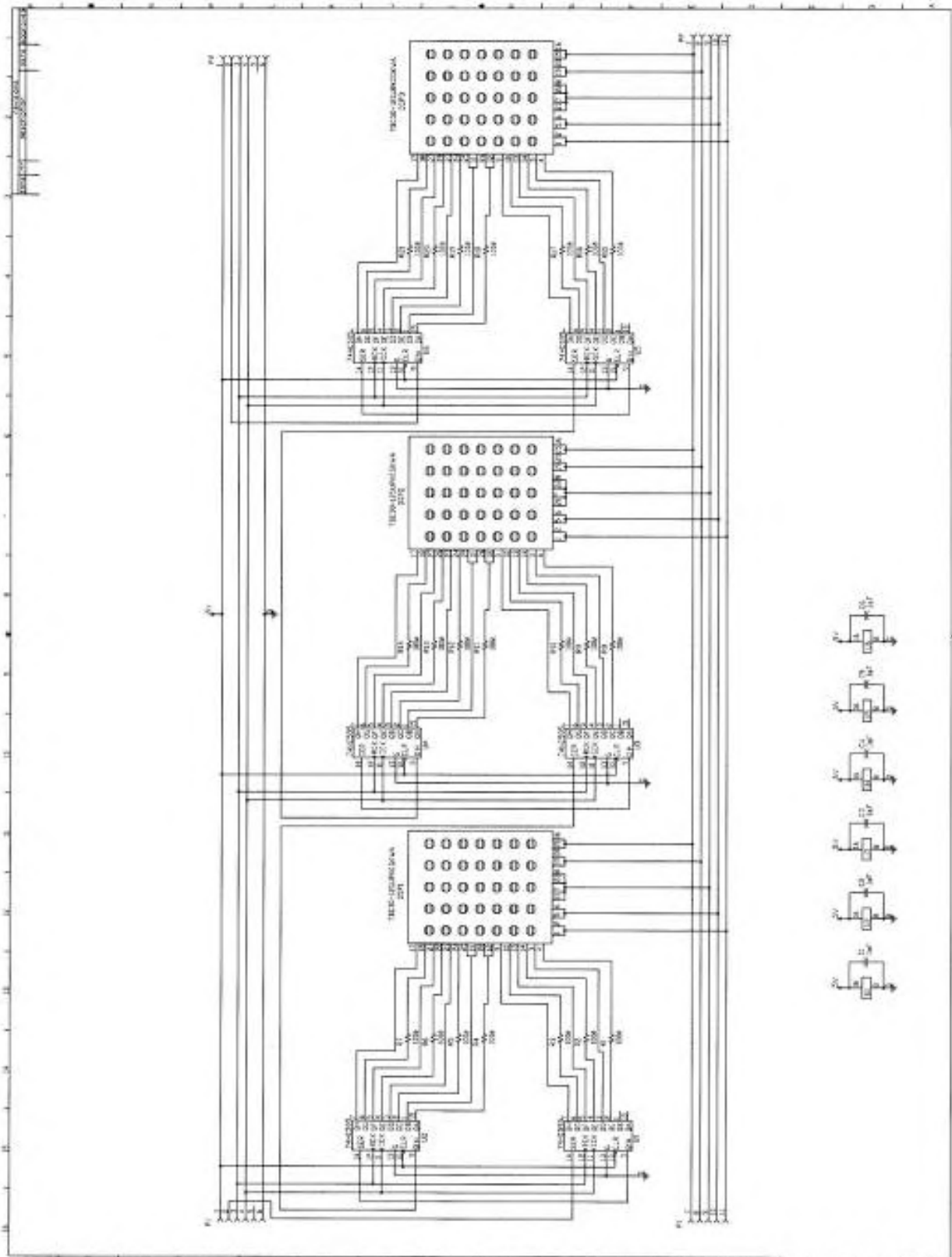

6. WARRANTY

BOB'S SPACE RACERS INC. 90 DAY COIN-OPERATED GAME WARRANTY

1. INCLUDED IN THIS WARRANTY Bob's Space Racers®, Inc. warrants to the original purchaser only that the equipment that is the subject of this sale conforms to its specifications, and is free from defects under normal service for a 90 day period from the original date of deliver. This warranty does not include any damages resulting from occurrences listed in paragraph 2 below. This warranty is not transferable under any circumstance. Any claims under this warranty must be received in writing by Bob's Space Racers®, Inc. within 120 days from date of delivery. Within a reasonable time of such written notification Bob's Space Racers®, Inc. will replace or repair any defective component of the equipment or part thereof which fails for reasons other than normal service, use, or wear. Bob's Space Racers®, Inc. reserves the right to request dated proof of purchase by the end user (original purchaser) at any time. Light bulbs are specifically excluded from this warranty and shall be the sole responsibility of the purchaser. Bob's Space Racers®, Inc., within its sole discretion, makes the final determination as to whether to repair or replace any component and whether any such repair or replacement shall be performed where the equipment is located or at its home facility in Volusia County, Florida, or another facility of its sole choice. Any and all freight charges for the purposes of repair or replacement shall be paid by the original purchaser. All defective parts shall be returned to Bob's Space Racers®, Inc. if requested. Bob's Space Racers®, Inc. does not warrant that the equipment will meet any original purchaser's specific requirements or that the operation of the equipment will be uninterrupted. These remedies are the original purchaser's exclusive remedies for breach of warranty.

2. EXCLUDED BY THIS WARRANTY Bob's Space Racers®, Inc. does not warrant (a) any product, components or parts not manufactured by Bob's Space Racers®, Inc.; (b) damages caused by use of the equipment for purposes other than those for which it was designed; (c) defects caused by failure to provide a suitable installation environment for the equipment; (d) damage caused by unauthorized attachments, modification, or service; (e) damage caused by normal wear and tear or improper power supply; (f) damage caused by accident or disaster such as fires, flood, lightning, and wind; or (g) any other abuse or misuse of the equipment.

3. EXCLUSIVE WARRANTY. THE FORGOING WARRANTY IS EXCLUSIVE AND IN LIEU OF ALL OTHER WARRANTIES OR REMEDIES, WHETHER WRITTEN, ORAL OR IMPLIED. THERE ARE NO WARRANTIES WHICH EXTEND BEYOND THE DESCRIPTION ON THE FACE HEREOF. ANY AND ALL IMPLIED WARRANTIES OF MERCHANTABILITY, FITNESS FOR A PARTICULAR PURPOSE, COURSE OF DEALING OR USAGE OF TRADE ARE HEREBY EXPRESSLY DISCLAIMED AND EXCLUDED.

4. REMEDIES LIMITED. UNDER NO CIRCUMSTANCES, EXCEPT TO THE EXTENT PROHIBITED BY APPLICABLE LAW, SHALL BOB'S SPACE RACERS®, INC. BE LIABLE FOR ANY LOSS OR DAMAGE, DIRECT OR INDIRECT, SPECIAL INCIDENTAL OR CONSEQUENTIAL ARISING OUT OF THE USE OR INABILITY TO USE THIS EQUIPMENT INCLUDING BUT NOT LIMITED TO ANY CLAIM FOR LOSS OR PROFITS, LOSS OF SAVINGS OR REVENUE, LOSS OF USE OF THE EQUIPMENT, OR ANY ASSOCIATED EQUIPMENT, FACILITIES OR SERVICE, DOWNTIME, THE CLAIMS OR COSTS OF THIRD PARTIES INCLUDING CUSTOMERS AND INJURY TO PROPERTY. Some states do not allow limitations on how long an implied warranty lasts or the exclusion or limitation of incidental or consequential damages, so the above limitations or exclusion may not apply to you. This warranty gives you specific legal rights, and you may also have other rights which vary from state to state.

5. NO OTHER WARRANTIES. Unless modified in writing and signed by both parties, this agreement is understood to be the complete and exclusive agreement between the parties, superseding all prior agreements, oral or written, and all other communications between the parties relating to the subject matter of this agreement. No employee or representative of Bob's Space Racers®, Inc. or any other party is authorized to make any other warranty or to assume any other liability in connection with the sale of its equipment.

6. TIME LIMIT FOR CLAIMS. Any claim for breach of warranty or claims under this warranty must be received in writing by Bob's Space Racers®, Inc. within 120 days following delivery of the equipment.

7. FUTURE CHANGES. Bob's Space Racers®, Inc. reserves the right to reserve, change or modify the construction and design of its equipment or any component part or parts thereof without incurring the obligations to make such changes or modifications in present equipment.

8. ALLOCATION OF RISKS. This agreement allocates the risks of equipment failure between Bob's Space Racers®, Inc. and the original purchaser. This allocation is recognized by both parties and is reflected in the price of the goods. THE PURCHASER ACKNOWLEDGES THAT IT HAS READ THIS AGREEMENT, UNDERSTANDS IT, AND IS BOUND BY ITS TERMS.

9. TO OBTAIN WARRANTY SERVICE. The original purchaser must, at his/her own expense, bring or ship the equipment to an authorized location for service. Additionally, the original purchaser must pay all freight, shipping or transportation charges for the return of the equipment from Bob's Space Racers®, Inc. to the original purchaser. Telephone or write:

Bob's Space Racers®, Inc.
427 15th Street
Daytona Beach, FL 32117
Telephone number: 386/677-0761
FAX: 386/677-0794

WHEN CALLING FOR SERVICE

1. When calling for service, please check the service manual first. Many times the answer to your problem has been addressed in this documentation.
2. Please make sure you have the serial number of the game ready when you call.
3. If this is a repeat call, please tell the service technician that you have made a previous call regarding this problem. This way we will be able to retrieve the history on your game allowing us to serve you better and save you time.
4. Please retain proof of purchase for your product. This might be requested for warranty repairs.
5. Please call from the game if possible since we might need you to check certain things on the game while we are on the telephone with you.

IF YOU HAVE ANY QUESTIONS OR COMMENTS, PLEASE CALL OUR SERVICE DEPARTMENT AT

(386) 677-0761

(MONDAY – FRIDAY, 8:30AM – 5:00PM EST, EXCLUDING HOLIDAYS)

(or)

EMAIL QUESTIONS TO: Tech@BobsSpaceRacers.com

(or)

**VISIT THE “CUSTOMER SUPPORT” SECTION ON OUR WEBSITE:
WWW.BOBSSPACERACERS.COM**

WATER BLAST

Fill Level Update (6/13/07)

NOTE: THIS UPDATE WILL ALLOW FOR THE PROPER FILLING LIMIT OF THE WATER BLAST GAME'S WATER TANK.

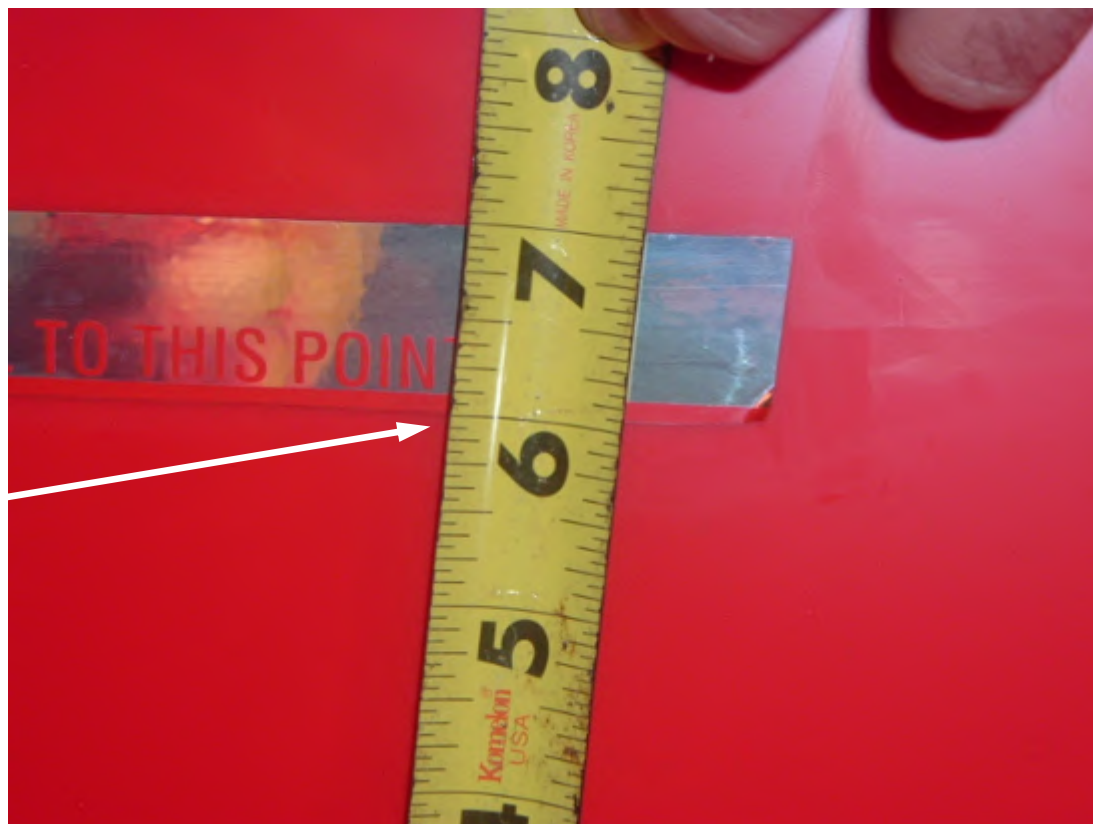

Correct fill distance

- INSTALL DECAL (AS SEEN IN THE ABOVE IMAGE) 6" FROM THE BOTTOM OF TANK.

WATER BLAST

Ventilation Update (6/13/07)

NOTE: THIS UPDATE WILL ALLOW FOR BETTER VENTILATION OF YOUR WATER BLAST GAME.

IMAGE 1



IMAGE 2



- If You Find That The Rear Metal Access Plate **Is** Bolted Directly To The Game (As Shown In “Image 1” And “Image 2”), Unbolt It And Insert Spacers, Washers, Or Nuts To Separate The Door/Plate From The Game. Be Sure To Evenly Space Each Bolt When Attaching the Rear Access Plate to the Game, So As To Not Bend It. Recommended Spacing Is a $\frac{1}{4}$ ” To $\frac{1}{2}$ ”. When Finished The Game Should Look Like “Image 3” And “Image 4”.

IMAGE 3



IMAGE 4

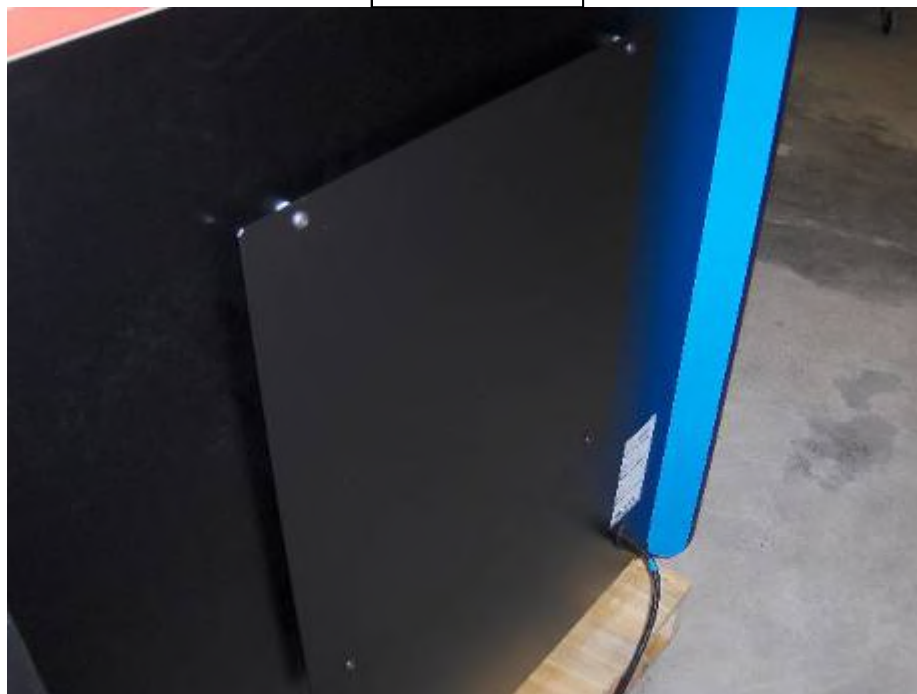

WATER BLAST

Water Change & Filter Cleaning Service (6/27/07)

NOTE: THIS UPDATE EXPLAINS HOW TO CHANGE THE WATER OF YOUR WATER BLAST GAME.

Water And Filter Should Be Cleaned Twice A Month, Or Every Two Weeks.

1. Turn off and unplug power to avoid risk of shock.
2. Open the front Coin/Ticket doors.
3. Remove the Coin Drawer. (Image 1)

IMAGE 1

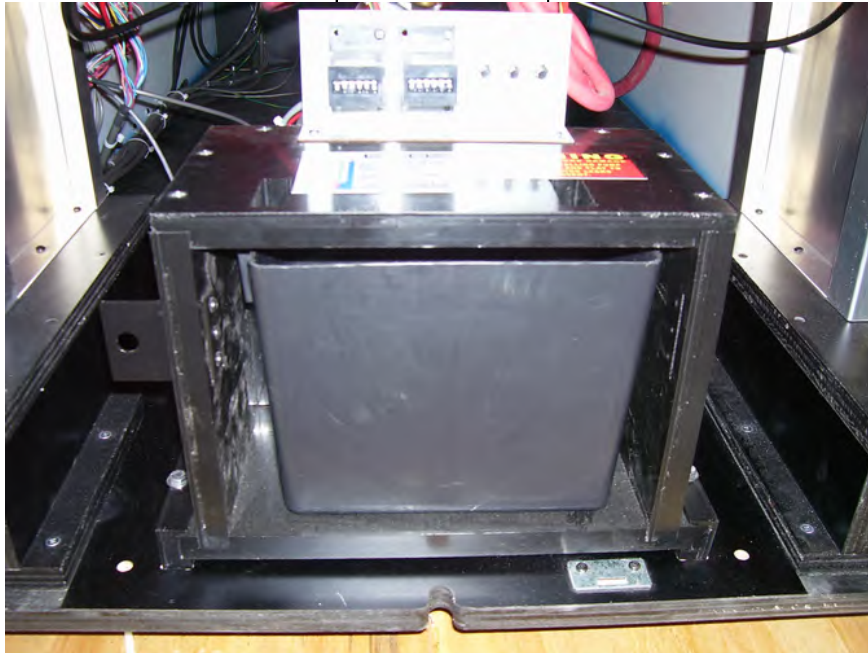

4. Locate and remove the Allen bolt from the bottom of the Coin Box. (Image 2)

IMAGE 2



5. Slide the Coin Box out of the game. Place it on the left side. (Image 3)

IMAGE 3



6. Slide the Pump Assembly forward. Be careful not to kink any hoses or pull any wires. (Image 4)

IMAGE 4

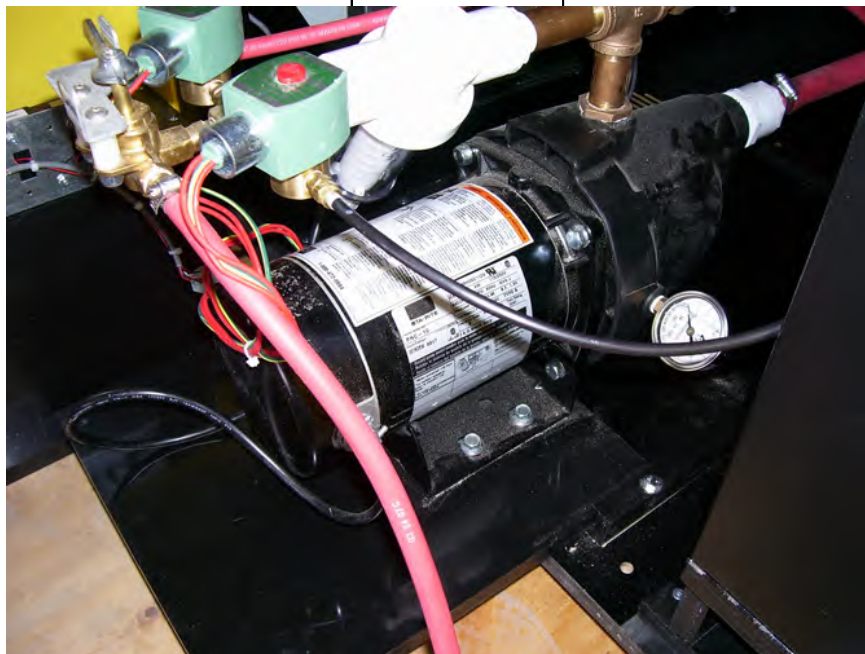

7. Turn the GAME/DRAIN Valve to the DRAIN position. (Image 5)

IMAGE 5



8. Hold the drain hose in a bucket. Using the PROGRAMMING Panel. Press PROGRAM. Press SELECT until DRAIN is displayed. Press STEP. The pump will turn on and start to fill the bucket.
9. Press STEP again to turn pump off. DO NOT RUN THE PUMP DRY.
10. Once the tank is empty, turn the DRAIN/GAME valve to GAME. (Image 6)

IMAGE 6

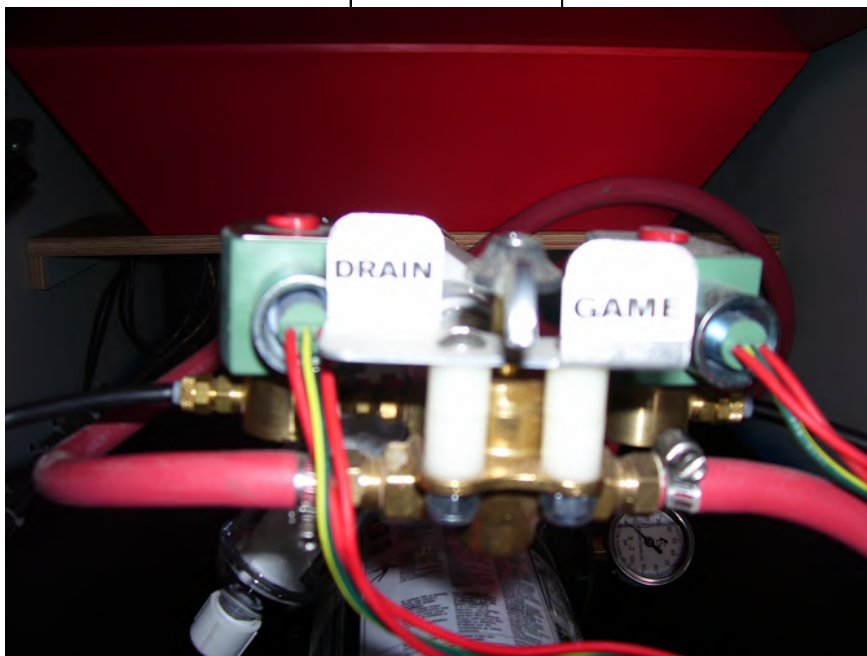

11. Press the PROGRAM button.
12. Unplug the pump from AC power outlet in game.

13. Unscrew the Clear-Vu filter. (Image 7)

IMAGE 7



14. Clean the bowl and the filter cartridge using a soft brush and mild detergent. (Image 8)

IMAGE 8



15. Carefully insert the filter cartridge into the base and screw on the bowl. DO NOT OVER TIGHTEN.

16. Plug the pump into AC power outlet in game.

17. Fill tank to the FILL LINE. The water should be 6 inches deep minimum. (Image 9)

IMAGE 9



18. Coin up the game and press PUSH TO START.
19. Play the game a few times to let the pump circulate the water.
20. INSPECT THE PUMP FOR ANY LEAKS before installing in the game.(Image 10)

IMAGE 10

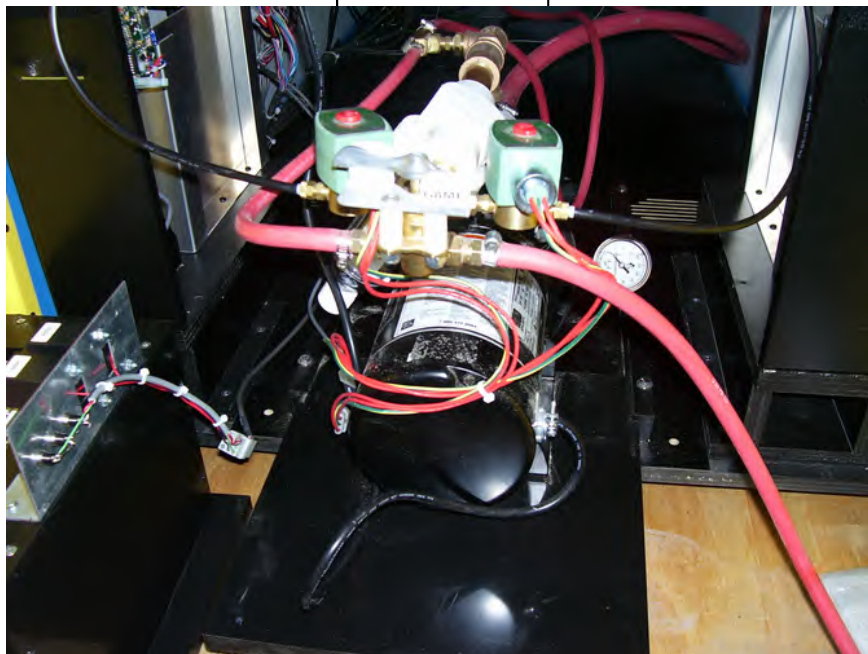

21. Slide Pump Assembly back into the game.
22. Slide the Coin Box Assembly back into the game.

23. Install Allen bolt in bottom of Coin Box Assembly.
24. Install Coin Drawer.
25. Inspect the inside of the game for any loose wires or water damage before closing.

IMAGE 11

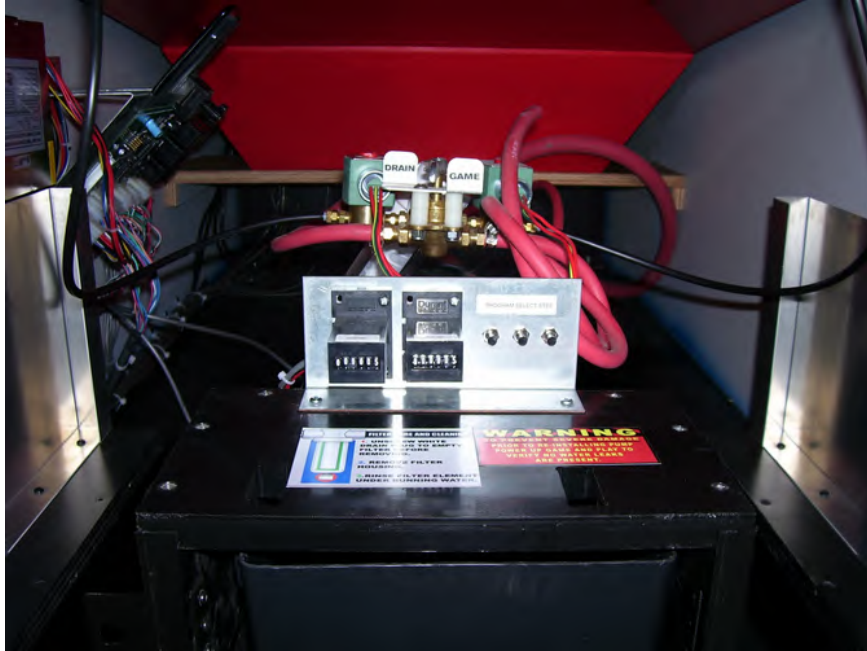

26. Shut the Coin/Ticket doors and lock them.
27. Re-plug power and turn on. (Play a test game to make sure game is working properly)

IF YOU HAVE ANY QUESTIONS OR COMMENTS, PLEASE CALL OUR SERVICE DEPARTMENT AT

1-386-677-0761

(or)

EMAIL QUESTIONS TO: **Tech@BobsSpaceRacers.com**