

SLAP HAPPY

Operation Manual



WARNING

Be sure to read this Operation Manual before use.

Bromley Incorporated
420 Crossen Avenue
ELK Grove Village IL 60007
847-427-0639

Before using the product, be sure to read the follow:**To maintain the safety:**

To ensure the safe usage of the product, be sure to read the following before using the product. The following instructions are intended for the users, operators and the personnel in charge of the operation of the product. After carefully reading and sufficiently understanding the warning display and cautions, handle the product appropriately. Be sure to keep this operation manual nearby the product or elsewhere convenient for referring to it when necessary.

Herein, explanations which require special attention are in sign of warning. Depending on the potentially hazardous degrees, the terms of NOTICE, WARNING CAUTION, etc. are used. Be sure to understand the content of the displays before reading the text.

**WARNING**

Disregarding this text could result in serious injury.

**Caution**

Disregarding this text could result in damage to the machine.

**Notice**

An advisory text to hint or help understanding.

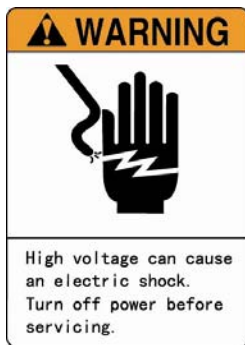
**High Voltage Warning:**

High voltage can cause an electric shock.

Turn off power before servicing.

**No Touching Warning:**

This part may cause an electric shock or the surface is overheating. Do not touch this part.

**High Temperature Warning:**

This part may be caused by scalding if somebody inadvertently does something.

—  **WARNING** —

Non-technical personnel who do not have technical knowledge and Expertise should refrain from performing such work that this manual requires the location's maintenance man or a serviceman to carry out, or work which is not explained in this manual. Failing to comply with this instruction can cause a severe accident such as electric shock.

CONTENTS

1.	Specifications.....	5
2.	Package Contents.....	6
3.	Installation, Fix and Transport.....	7
4.	Connecting the power cord and grounding.....	10
5.	Game description.....	11
6.	Switch.....	12
7.	Adjustment.....	13
8.	Maintenance and inspections.....	17
9.	Troubleshooting.....	19
10.	Overall Construction.....	20

I/O chart

Wiring Diagram

DEFINITION OF LOCATION'S MAINTENANCE MAN AND SERVICEMAN**WARNING**

Non-technical personnel who do not have technical knowledge and expertise should refrain from performing such work that this manual requires the location's maintenance man or a serviceman to carry out, or work which is not explained in this manual. Failing to comply with this instruction can cause a severe accident such as electric shock.

Ensure that parts replacement, servicing & inspections, and troubleshooting are performed by the locations maintenance man or the serviceman. It is instructed herein that particularly hazardous work should be performed by the serviceman who has technical expertise and knowledge.

General Description

- ✧ When you see the number you want, tap the button to freeze it.
- ✧ You have 8 seconds. ...Good luck!

1. Specifications



Specifications

1 Rated power supply:	AC110V 50/60Hz
2 Power Consumption:	Min power consumption 80W Max power consumption 110W
3 Dimensions:	(L)43.31 × (W)27.95 × (H)89.17 (inch)
4 Weight:	NW: 269 pounds GW: 337 pounds
5 Environment Condition:	Temperature(indoor):-10F~+40F Humidity: ≤90% Atmospheric pressure:86Pa~106Pa



Notice





Game parameters are subject change without notice.

2. Package contents

3.1 Body Assembly: 1 unit

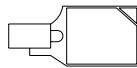
- Make sure that all the parts shown below are included in product package.
- If any parts are missing, contact your distributor.

3.2 Accessories

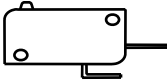
No	Part No.	Name	Specification	Illustration	Q'ty	Note
1	T107-716-000	Operation	ENGLISH		1	
2	T107-401-000	Key	GU071 #1		7	
3	T107-413-000	Bulb	12V3W		2	
4	T107-815-000	Power wire	15A/110V 70.87 inches		1	
5	T107-415-000	Lamp	110V/20W		1	
6	T107-416-000	Fuse	3A/110V Φ0.20*0.79 inches		2	
8	T107-417-000	Micro SW	3A 125/250V		2	



Notice

Game parameters are subject change without notice.

3. Installation and transport



WARNING

This product is an indoor game machine. Do not install it outside.

Even indoors, Avoid installing in places mentioned below.

- Places subject to rain or water leakage, or places subject to high humidity in the proximity of an indoor swimming pool and or shower, etc.
- Places subject to direct sunlight, or places subject to high temperatures in the proximity of heating units, etc.
- Places filled with inflammable gas or vicinity of highly inflammable/volatile chemicals or hazardous matter.
- Dusty places.
- The machine must be sited on level ground which is firm and free from holes etc. The surface the ride stands on should not be slippery.
- Places subject to any type of violent impact.
- Vicinity of anti-disaster facilities such as fire exits and fire extinguishers.



LIMITATIONS OF USAGE REQUIREMENTS

- Be sure to check the Electrical Specifications. Ensure that this product is compatible with the location's power supply, voltage and frequency requirement. A plate describing Electrical Specifications is attached to the product. Non-compliance with the Electrical Specifications can cause a fire and electric shock.
- Putting many loads on one electrical outlet can cause generation of heat and a fire resulting from overload.



Location to avoid installing

Warning:

Do not leave the machine on a slope, otherwise the machine may topple or cause unforeseen accidents.

Play zone

Space for Operation and Maintenance

This machine requires space for playing the game (play zone) and for maintenance (maintenance zone) as shown below. Be sure to leave enough space when installing the machine.

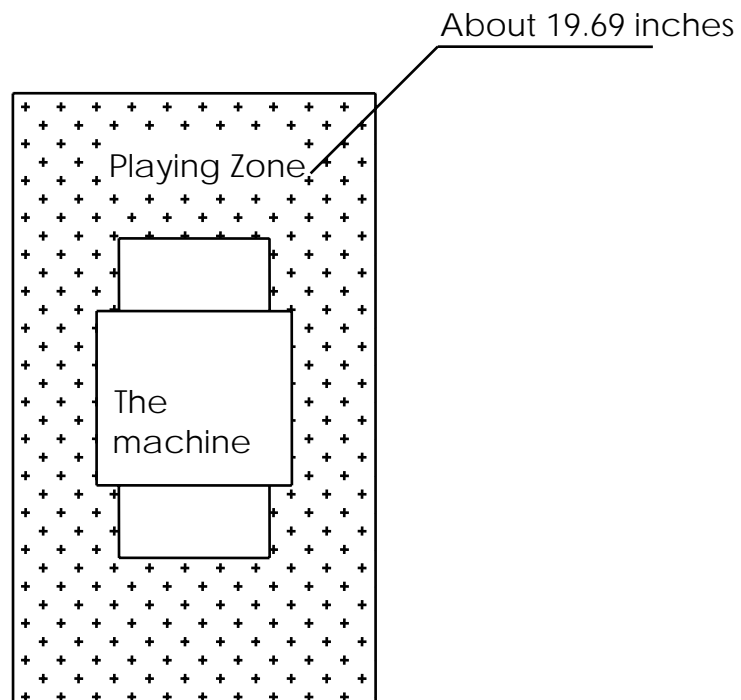



Moving and transport

Notice:

- Be careful not to damage the machine during transport.
- Do not give a shock to the molded parts. These parts are fragile.
- Be careful not to give a shock to the machine when bringing it down from a higher level.
- Unplug game before moving.
- Do not lay game on side during transport.

1. When moving a short distance, you need one person on each side of the machine. Tilt the machine about 30 degree to let the castors touch the ground and move.

2. When moving a far distance. It would be suggested to wrap and package the game.

NOTE: BE CAREFUL OF THE MARQUEE. IT IS FRAGILE.

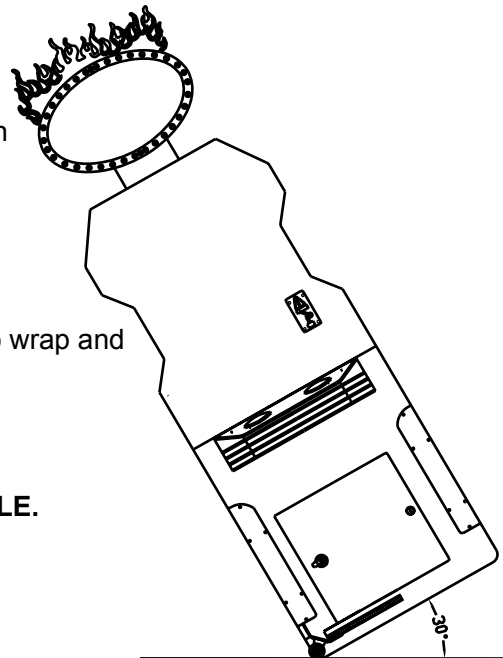

4. Connecting the power cord and grounding



The connection:

Insert the plug of power cord into the power socket of the machine.

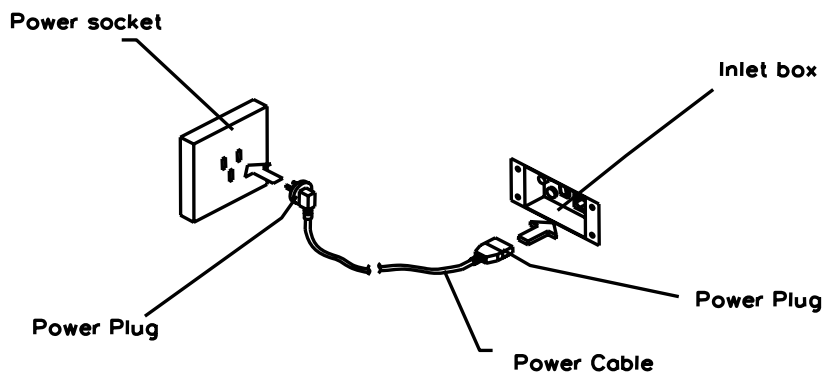

Warning:

- ★ Do not put heavy items on power cord.

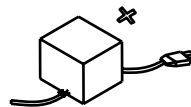

- ★ Do not touch the power plug with a wet hand.

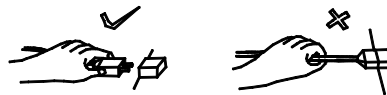

- ★ Do not draw or twist the cord.
- ★ Do not place the cord near a heat source.
- ★ Do not place the cord where the player can easily touch or kick.



- ★ Run this machine with the correct power configuration.

5. Game description



The instruction of how to play

When you see the number you want, tap the button to freeze it.

You have 8 seconds.... GOOD LUCK!



1. LED: Display the score.
2. LED: Display the spare time.
3. LED: Display the spare credit.
4. Button: Hit the button the change the score.
5. The instruction of how to play.

6. Switches

The Main board:

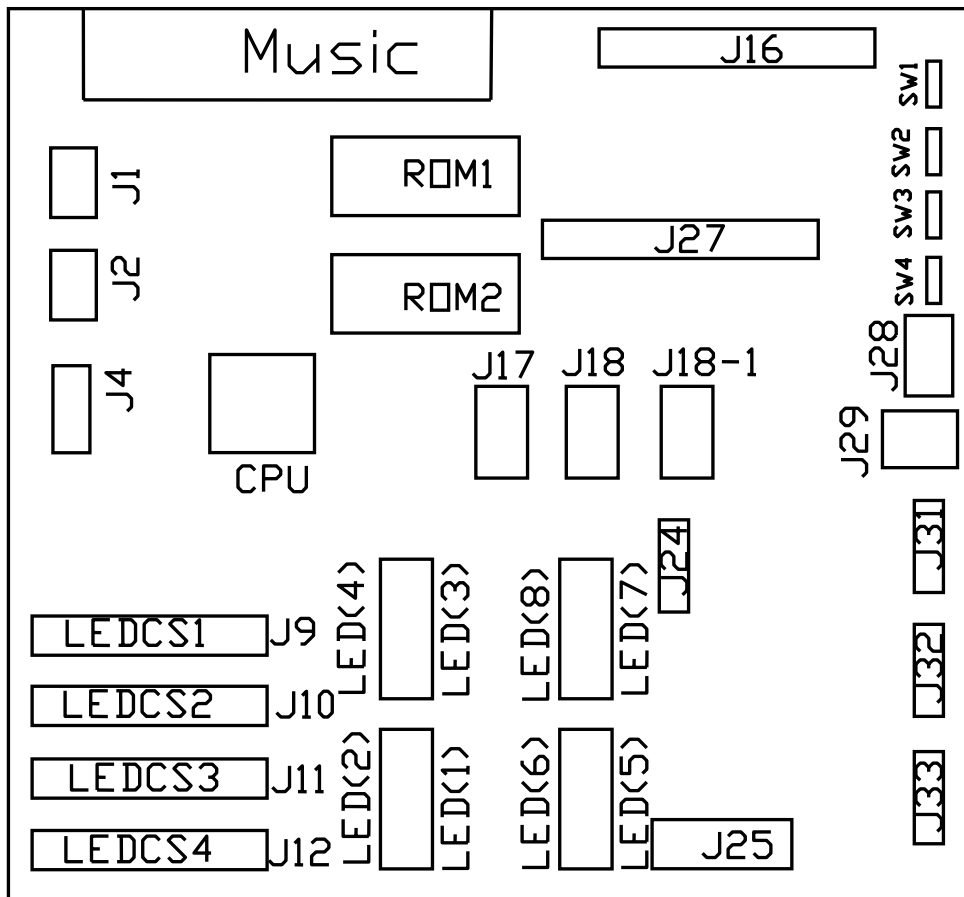

The DIP SW Locations

Game parameters are controlled by a dip switch banks labeled SW. Each bank eight switches where in the SW1-2 for example refers to bank 2 switch position 1.

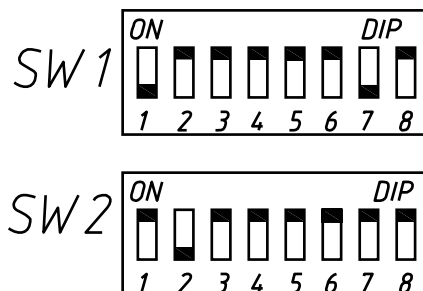

Note: Game parameters are subject change without notice.

7. Adjustment

1. Coin per game:

This switch is used for the coin Mech, adjusting it to setting how many coins in one game. There have 4 options. It is controlled by SW11~SW12.

Coin per game	Options	SW11	SW12	Note
SW11~SW12	0	On	On	Free plays
	1	OFF	ON	1coin/credit
	2	on	off	2coins/credit
	3	Off	Off	3coins/credit

2. Ticket Payout:

Adjust the group of tickets out. There are 4 options for user to select. It is controlled by SW13~SW14.

Group	Options	SW13	SW14	Note
SW13~ SW14	1	ON	ON	Group 1
	2	Off	On	Group 2
	3	On	Off	Group 3
	4	Off	Off	Group 4

Score	Group 1	Group 2	Group 3	Group 4
50~99	3tickets	3tickets	4tickets	6tickets
100~199	4tickets	4tickets	6tickets	8tickets
200~299	5tickets	5tickets	10tickets	14tickets
300~399	10tickets	6tickets	15tickets	20tickets
400~749	25tickets	12tickets	35tickets	50tickets
750~899	50tickets	25tickets	75tickets	100tickets
900~999	100tickets	50tickets	150tickets	200tickets

3. Continue shoot:

Adjust the mode of shooting. There are 2 option for user to select. It is controlled by SW15.

Mode	Options	SW15	Note
SW16	Yes	ON	
	no	off	

4. Playing Time:

Adjust the game time. There are 4 options for user to select. It is controlled by SW16~SW17.

Playing Time	Options	SW16	SW17	Note
SW16~ SW17	8s	On	On	
	10s	Off	On	
	12s	ON	OFF	
	16s	Off	Off	

5. Attract Music:

Adjust ON or OFF the attract music. There are 2 options for user to select. It is controlled by SW18.

Attract Music	Options	SW18	Note
SW18	1	ON	
	2	Off	

6. Average Ticket per game.

Payout	Content	SW21	SW22	SW23	SW24	SW25	Note
SW21~ SW25	5	on	on	on	on	on	
	6	off	on	on	on	on	
	7	on	off	on	on	on	
	8	off	off	on	on	on	
	9	on	on	off	on	on	
	10	OFF	ON	OFF	ON	ON	
	11	on	off	off	on	on	
	12	off	off	off	on	on	
	13	on	on	on	off	on	
	14	off	on	on	off	on	
	15	on	off	on	off	on	
	16	off	off	on	off	on	
	17	on	on	off	off	on	
	18	off	on	off	off	on	
	19	on	off	off	off	on	
	20	off	off	off	off	on	
	21	on	on	on	on	on	
	22	off	on	on	on	off	

7. Fault display



When starting the game machine or entering the test condition, the related contents show as the below information.

INPUT	Content	INPUT	Content
J26-1	1#Coin1	J26-9	2#TicketReset
J26-2	1#Coin2	J26-10	2#TicketSignal
J26-3	1#Ticket Reset	J26-11	2#StopButton
J26-4	1#Ticket Signal	J26-12	
J26-5	1#StopButton	J26-13	
J26-6		J26-14	
J26-7	2#Coin1	J26-15	
J26-8	2#Coin2	J26-16	



The following form represents that the related output in the list should be checked when any devices of the machine couldn't work.

OUTPUT	Content	OUTPUT	Conent
J31-1	1#Coin amount	J33-17	MarqueeLamp1
J31-2	1#Ticket amount	J33-18	MarqueeLamp2
J31-3	1#Button Lamp	J33-19	MarqueeLamp3
J31-4	1#Ticket Drive	J33-20	MarqueeLamp4
J31-5	1#Arrow Lamp1	J33-21	MarqueeLamp5
J31-6	1#Arrow Lamp2	J33-22	MarqueeLamp6
J31-7	1#Arrow Lamp3	J33-23	MarqueeLamp7
J31-8		J33-24	MarqueeLamp8
J32-9	2#Coin amount	J25-25	1# 2# Lighting1
J32-10	2#Tcket amount	J25-26	1# 2# Lighting2
J32-11	2#Button Lamp	J25-27	1# 2# Lighting3
J32-12	2#Ticket Drive	J25-28	1# 2# Lighting4
J32-13	2#Arrow Lamp1	J25-29	1# 2# Lighting5
J32-14	2#Arrow Lamp2	J25-30	1# 2# Lighting6
J32-15	2#Arrow Lamp3	J25-31	Top lamp
J32-16		J25-32	Underside lamp

Display			
1# Side		2# Side	
Coin	LED<2>3-4	Coin	LED<4>3-4
Time	LED<2>5	Time	LED<4>5
High Score	LED<2>6-8	High Score	LED<4>6-8
Small Score	LED<1>6-8	Small Score	LED<3>6-8
Time Lamp	LED<5>	Time Lamp1	LED<7>
LED lamp	LED<6>	Time Lamp2	LED<8>

8. Maintenance and inspections



Safety checks

Check the points listed before operating the machine. These checks are necessary for safe machine operation.

1. Is there sufficient play zone around the machine?



HANDLING PRECAUTIONS

When installing or inspecting the machine, be very careful of the following points and pay attention to ensure that the player can enjoy the game safely.

Non-compliance with the following points or inappropriate handling running counter to the cautionary matters herein stated can cause personal injury or damage to the machine.

NOTICE:

- Before performing work, be sure to turn power off. Performing the work without turning power off can cause an electric shock or short circuit. In the case work should be performed in the status of power on, this manual always states to that effect.
- To avoid electric shock or short circuit, do not plug in or unplug quickly.
- Do not expose Power Cords and Earth Wires are susceptible to damage.
- Damaged cords and wires can cause electric shock or short circuit.
- When or after installing the product, do not unnecessarily pull the power cord. If damaged, the power cord can cause a fire or electric shock.
- In case the power cord is damaged, ask for replacement through where the product was purchased from or the office herein stated. Using the cord as is damaged can cause fire, electric shock or leakage.
- Be sure to perform grounding appropriately. In appropriate grounding can cause an electric shock.
- Be sure to use fuses meeting specified rating. Using fuses exceeding can cause an electric shock.

OPERATION WARNING

- Should a problem occur, switch OFF the power immediately and stop operating the machine. Then unplug the power cord the service outlet. Operating the machine without correcting the problem may cause a fire or accident.
- Dust accumulated on the power plug may cause a fire. Check the plug regularly and remove any dust.
- Insert the power plug securely into the service outlet. Poor contact may cause overheating, resulting in fire or burns.
- Before operating the machine, always check that the machine has been installed according to the instructions and procedures in this Operation Manual. Failure to install correctly may result in a fire, electric shock, injury, or equipment malfunction.
- The warning labels describe important safety precautions. Observe the points below.
- To make sure that the warning labels attached to the machine are easily legible, install the machine in a well-lit location, and keep the labels clean at all times. Also make sure that the labels are not behind other game machines.
- Do not remove to alter the warning labels.
- Always turn off the power first to protect other personnel from electric shock, accidents and injury, and to prevent damage to electrical circuits.
- If a fault occurs, first check that all the connectors are firmly connected.
- Contact your distributor if none of the cases below applies to the problem, or if the action listed does not appear to resolve the problem.
- To avoid injury resulting from down, and electric shock due to spilled drinks, instruct the player not to place heavy items or drinks on the product.

**Notice**

To avoid injury and trouble, be sure to constantly give careful attention to the behavior and manner of the visitors and players.

Replace the Light belt and Button lamp

Remove the acrylic board under the control panel. Unplug the screws shown in the picture.

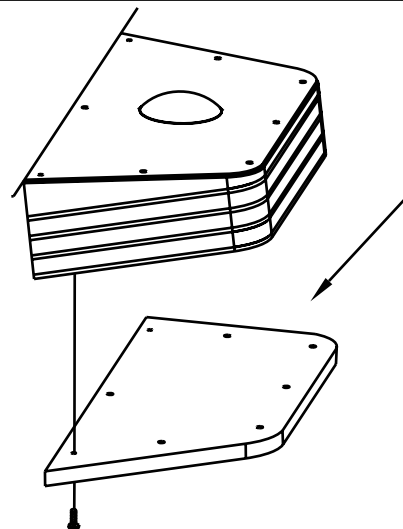

9. Troubleshooting

Malfunction	Cause	Settlement
The machine can't open.	<ol style="list-style-type: none"> 1. No power or wrong voltage 2. Plug is poor contacted 3. The electric circuit was short 	<ol style="list-style-type: none"> 1. Power on. Check the voltage. 2. Plug on again. 3. Check the electric circuit.
The whole game does not run	I/O board adjust wrong	Check the I/O chart
Lamp can't light on	The lamp was burning out or was open circuit.	Replace a new lamp or check the circuit.
The machine control failure	The circuit was break down or the control parts were failure	Check the circuit or the control parts and maintain them.
No sound is emitted.	Sound volume adjustment is not appropriate.	Adjust sound volume.

10. Overall construction

10.1 Game components

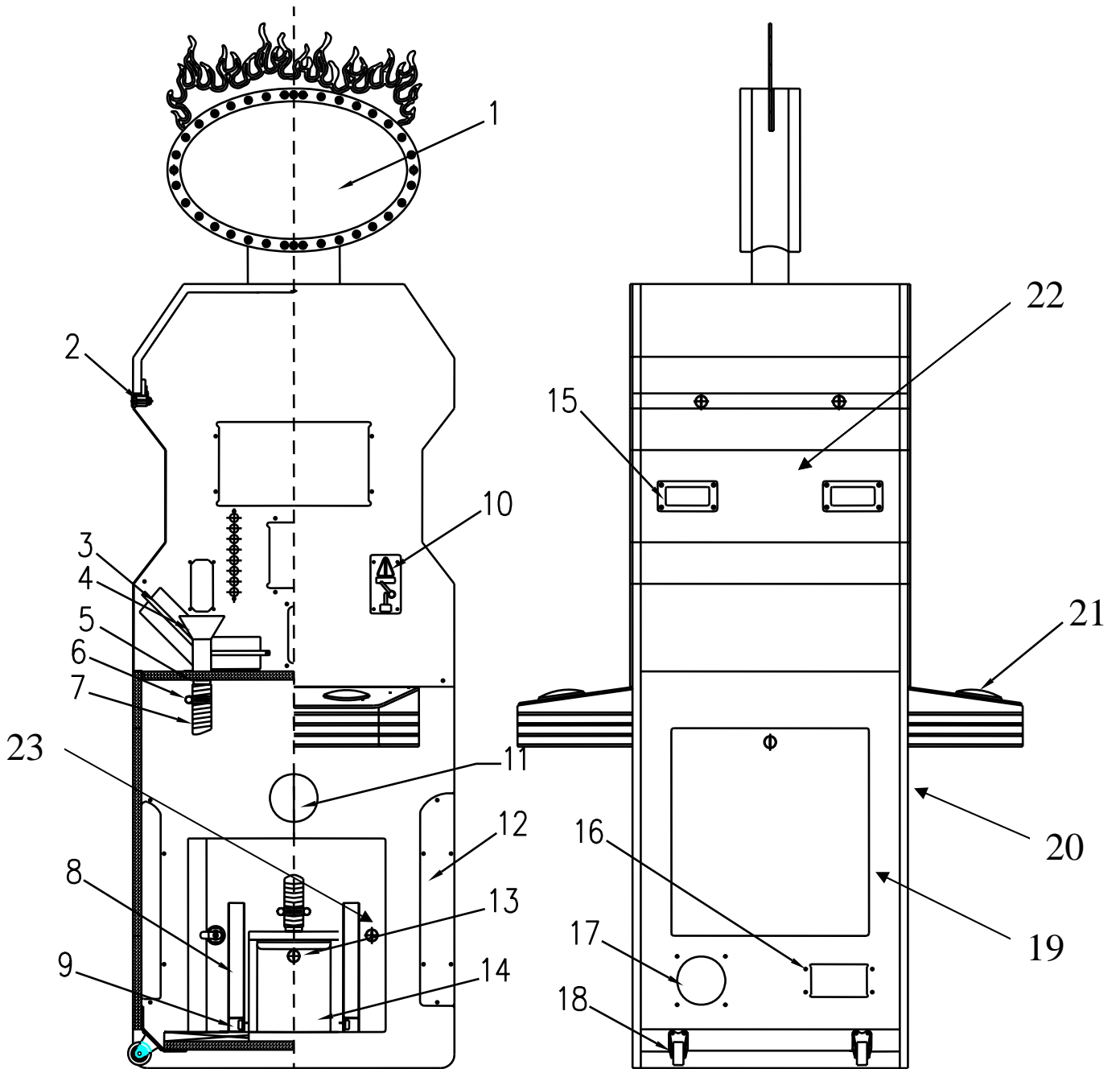

Parts list:

Item	Part NO.	Code	Content	Q'ty	Specification	Note
1	T107-001-000	YJSK2-01-00A	Marquee assemble	1	Assy.	
2	T107-401-000		Lock	5	171	
3	T107-101-000	YJSK2-00-04	Light belt holder A	8	Stainless steel	
4	T107-102-000	YJSK2-00-03A	Coin Chute	2	Q235	
5	T107-103-000	YJSK2-00-05	Base(Coin Chute)	2	Q235	
6	T107-402-000		Buckle	4	φ 1.38- φ 1.65inches	
7	T107-403-000	YJSK2-00-06A	Coin Channel	2	φ 1.67inches	
8	T107-404-000	YJSK2-00-08	Ticket Bin	2	Q235	
9	T107-104-000	YJSK2-00-09	SW Holder	2	Q235	
10	T107-405-000		Coin Mech	2	TW-100	
11	T107-105-000		Speaker Net	2		
12	T107-601-000	YJSK2-00-13A	Lamp belt rack	4	δ =1.5	
13	T107-406-000		Cash Box Lock	1	2222	
14	T107-106-000	YJSK2-00-10A	Cash Box	2	Q235	
15	T107-602-000		Handle	2	Latex (black)	
16	T107-107-000		Wire Box	1		
17	T107-407-000		Fans	1	SUNON-DP200A	
18	T107-408-000		Castor	2		
19	T107-002-000		Cabinet	1	Assy.	
20	T107-108-000		Ticket cover	2	Q235	
21	T107-003-000		Control Panel Assemble	2		
22	T107-109-000		Service door	1	Q235	
23	T107-603-000		Indicator cover	2	ABS	

10.2 Control Panel Assemble

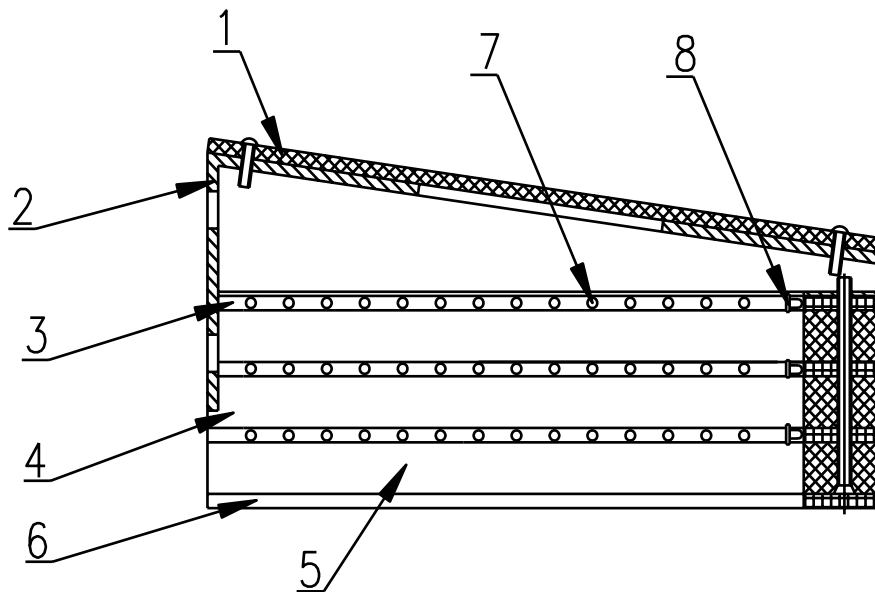

Parts list:

Item	Part NO.	Code	Content	Q'ty	Specification	Note
1	T107-604-000	YJSK2-02-01A	Control Panel PC	2	PC($\delta =5$)	
2	T107-110-000	YJSK2-02-02A	Fixation Frame	2	Q235	
3	T107-605-000	YJSK2-02-03	Green Plastic	2		
4	T107-501-000	YJSK2-02-04M	Wooden piece-1	2	$\delta =18$	
5	T107-502-000	YJSK2-02-05M	Wooden piece-2	2	$\delta =18$	
6	T107-606-000	YJSK2-02-06	Blue Plastic	2		
7	T107-801-000		Lamp board 1	4	YJSK-45LED.PCB	
8	T107-802-000		Lamp board 2	2	YJSK-72LED.PCB	

10.3 Marquee Assemble

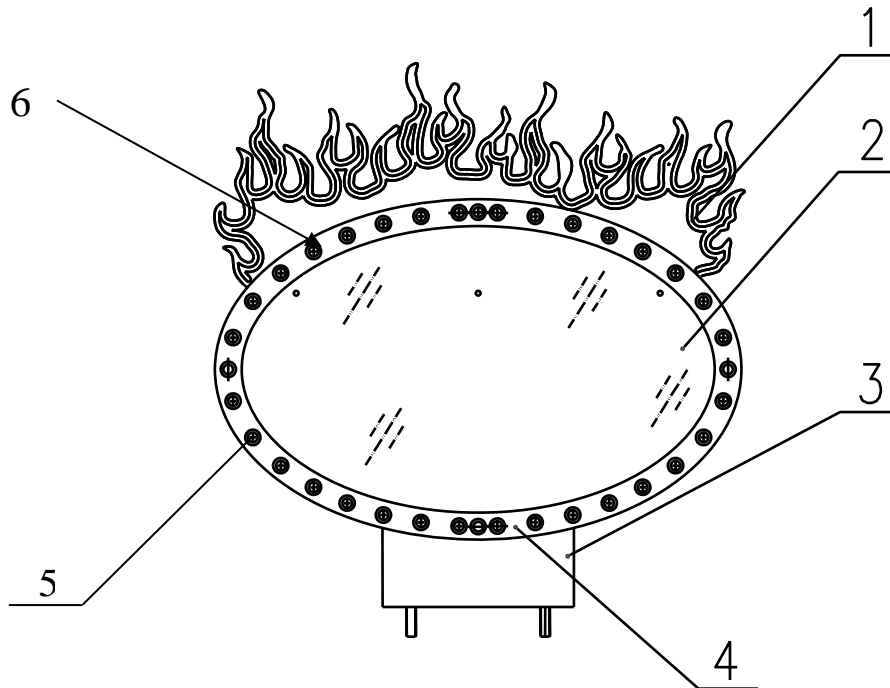

Parts list:

Item	Part NO.	Code	Content	Q'ty	Specification	Note
1	T107-607-000	YJSK2.01-01A	Flambeau	1	plastic ($\delta = 10$)	
2	T107-608-000	YJSK2-01-02A	Graphic Plastic	2	plastic ($\delta = 4$)	
3	T107-111-000	YJSK2-01-03A	Marquee bracket	1	Q235($\delta = 2$)	
4	T107-112-000	LJF.02-06	Marquee Frame	2	White ABS	
5	T107-801-000		Marquee light board	4	YJSK-LEDDXac.PCI	
6	T107-802-000		Marquee light board	4	YJSK-LEDDXbd.PCI	

10.4 Electric Part:

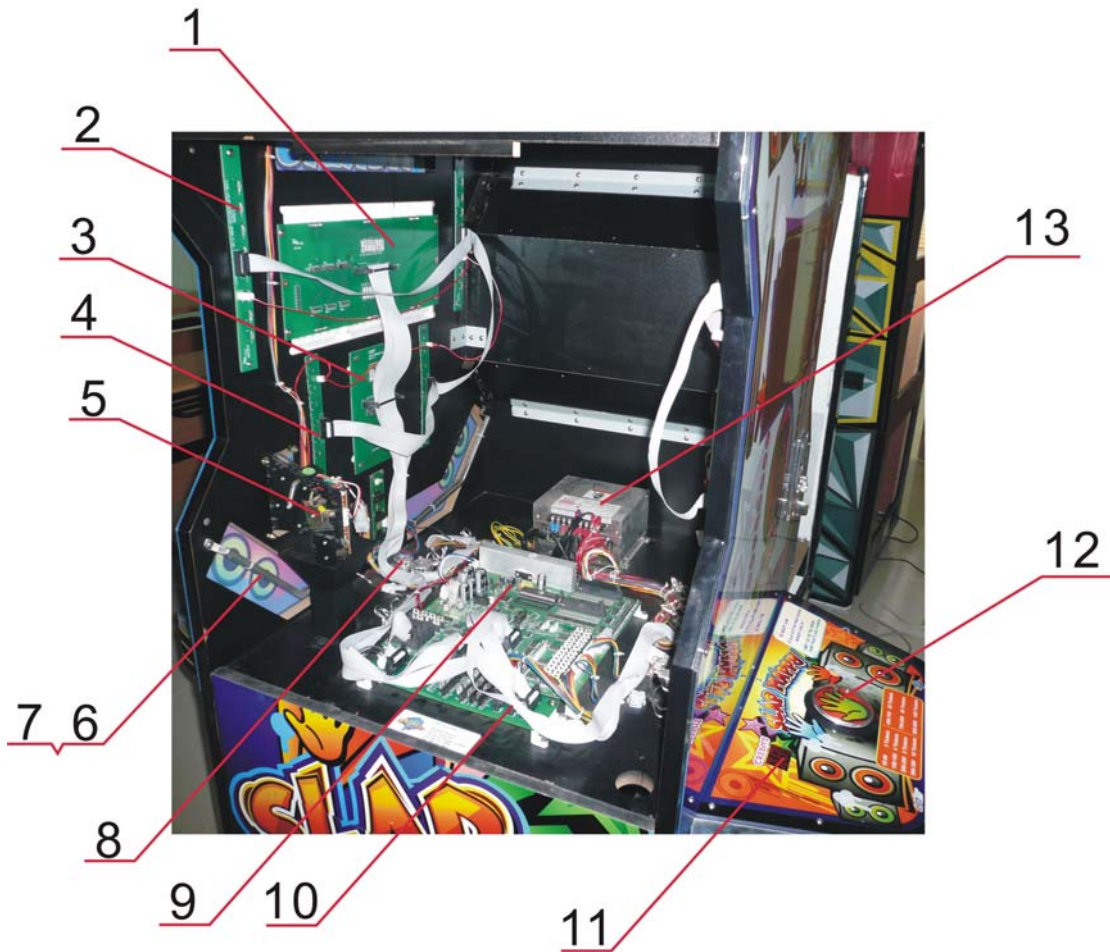

Parts list:

No.	Part NO.	Code	Content	Q'ty	Specification	Note
1	T107-803-000		LED board(Score displays)	2	LED50B3RG.PCB	
2	T107-804-000		LED board	4	YJSK-16LED.PCB	
3	T107-805-000		LED board(Time displays)	2	YJSK.LED50B1.PCB	
4	T107-806-000		Lamp board	4	LED-YJSK.PCB	
5	T107-405-000		Coin mech.	2	TW-100	
6	T107-807-000		Light belt	4	L=9.45inches DC12V	
7	T107-101-000	YJSK2-00-04	Light belt holder	4		
8	T107-409-000		Lamp Control	4	LM12-250	
9	T107-808-000		Main Board	1	V9	
10	T107-809-000		Driver Board	1	YJSK.LED50QD.PCB	
11	T107-810-000		LED board(Credit displays)	2	YJSK.LED08B2.PCB	
12	T107-410-000		Button	2	Assy.	
13	T107-411-000		Power box	1	EPM-S250D12+28	

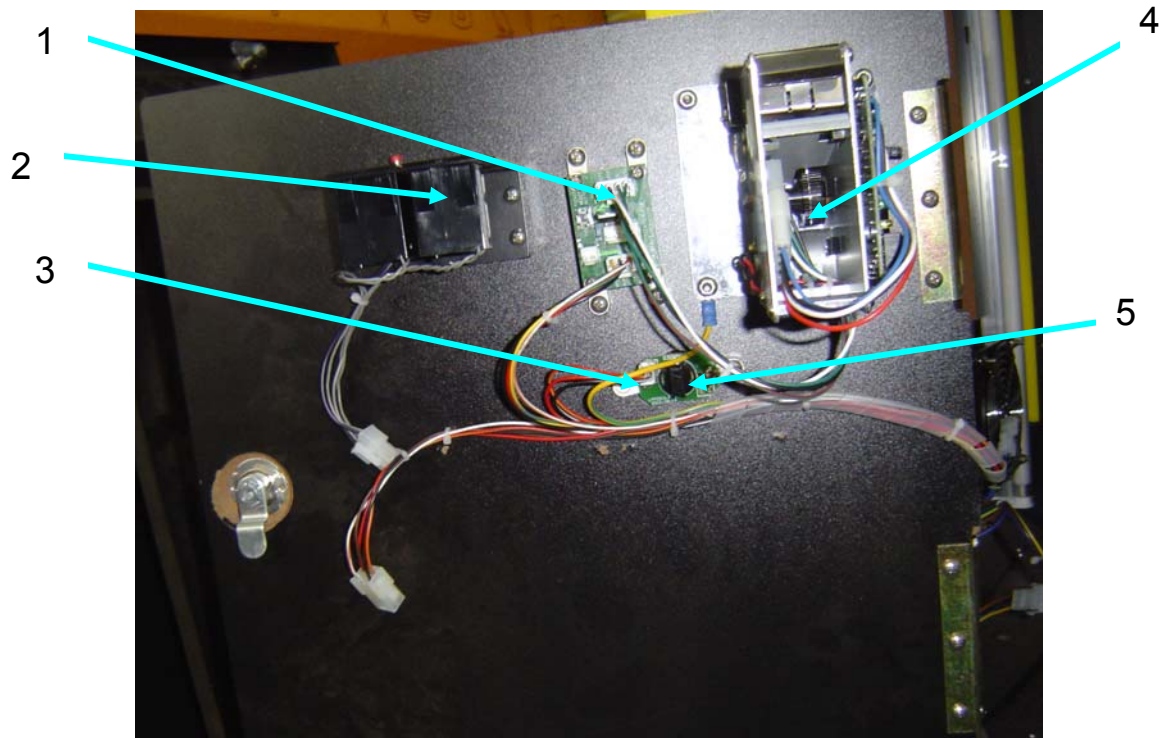



Part list:

No.	Part NO.	Code	Content	Q'ty	Specification	Note
1	T107-811-000		Ticket Board	2	Tick-CH.PCB	
2	T107-113-000		Counter Assy.	2		
3	T107-812-000		LED lamp(ticket indicate)	2	LMP001.PCB	
4	T107-412-000		Ticket Assy	2	TD963CR	
5	T107-413-000		LED lamp	2	DC12V white	

10.5 Game decal:



No.	Part NO.	Code	Content	Q'ty	Specification	Note
1	T107-801-000		Marquee Lamp board-1	4	YJSK-LEDDXac.PCB	
2	T107-701-000	YJSK2-HM-06A	Marquee decal	2	21.50X13.78(δ 3 Plastic)	
3	T107-802-000		Marquee Lamp board-2	4	YJSK-LEDDXbd.PCB	
4	T107-813-000		Marquee Lamp board-3	1	LED48-NC.PCB	
5	T107-609-000	YJSK2-00-01A	Main panel PC	2		
6	T107-702-000	YJSK2-HM-02A	Main panel decal	2	27.95X34.65(δ 5 Plastic)	
7	T107-703-000	YJSK2-HM-15A	Starboard decal	1	12.20X9.45 inches	
8	T107-704-000	YJSK2-HM-05A	Button decal	4	2.95X2.95 inches	
9	T107-705-000	YJSK2-HM-01A	Nearside decal	1	12.20X9.45 inches	
10	T107-706-000	YJSK2-HM-04A	Console decal	2	21.77X10.08(δ5PC)	
11	T107-707-000	YJSK2-HM-03A	Score decal	2	6.89X9.25(δ0.2PVC)	
12	T107-708-000	YJSK2-HM-18A	R-lamp Plastic	2	Clarity Plastic(yellow)	
13	T107-814-000		Lamp belt	4		
14	T107-114-000	YJSK2-00-11A	Protect board 1	2	Stainless steel (δ =1)	
15	T107-709-000	YJSK2-HM-16A	Front door decal	2	12.20X9.45 inches	
16	T107-414-000		Speaker	2	4" 8Ω 10W	
17	T107-710-000	YJSK2-HM-09	Ticket decal	2	2.36X0.79 inches	
18	T107-711-000	YJSK2-HM-17A	L-lamp Plastic	2	Clarity Plastic(yellow)	
19	T107-115-000	YJSK2-00-12A	Protect board 2	1	Stainless steel (δ =1)	
	T107-711-000	YJSK2-HM-10	Coin counter decal	1		
20	T107-712-000	YJSK2-HM-11	Ticket counter decal	1		
21	T107-713-000	YJSK2-HM-12	Ticket reset decal	1		
22	T107-714-000	YJSK2-HM-08	High voltage decal	1		
23	T107-715-000	YJSK2-HM-07	Service decal	1	