



PLACE SERIAL NUMBER LABEL HERE



# FACTORY CONTACT INFORMATION



BAY TEK GAMES INC.  
Pulaski Industrial Park  
1077 East. Glenbrook Drive  
Pulaski, WI 54162 USA

## JOIN OUR SERVICE FIRST NETWORK!

This free service is intended to keep you up to date on the latest game information, early notification of parts specials, pertinent technical bulletins, updates on retro fit parts, software upgrades, and much more.

Log on to: [www.baytekgames.com/parts](http://www.baytekgames.com/parts)  
then click on the Parts N' Service tab, or scan the QR code to the right with your Smart-phone to jump straight to this game's parts page!



### SALES

P: 920.822.3951  
F: 920.822.8936  
E: [sales@baytekgames.com](mailto:sales@baytekgames.com)

### PARTS

P: 920.822.3951 X 1101  
F: 920.822.1496  
E: [parts@baytekgames.com](mailto:parts@baytekgames.com)

### SERVICE

P: 920.822.3951 X 1102  
F: 920.822.1496  
E: [service@baytekgames.com](mailto:service@baytekgames.com)

MON - FRI  
8 AM - 5 PM C.S.T.

All games are proudly manufactured at our factory in Pulaski, Wisconsin, USA

# TABLE OF CONTENTS

FACTORY CONTACT INFORMATION .....	2
WELCOME TO: Sink It .....	4
HOW TO PLAY .....	5
SPECIFICATIONS .....	6
SAFETY PRECAUTIONS .....	6
QUICK SETUP GUIDE .....	7
DIP SWITCH SETTINGS .....	8
MAIN MENU FUNCTIONS .....	9
CLEAR CREDITS .....	9
GAME SETUP .....	10
TICKET PATTERNS .....	11
DIAGNOSTICS MENU .....	12
MACHINE SETUP .....	13
REPORTS .....	14
SOFTWARE UPDATE .....	15
MAINBOARD PINOUT .....	16
MINIGEN PINOUT .....	17-19
WIRING DIAGRAMS .....	20-24
TROUBLESHOOTING GUIDE .....	25-32
POWER SUPPLY DIAGNOSTICS .....	33
BILL ACCEPTOR DIAGNOSTICS .....	34
HOW TO: ACCESS MAINBOARD .....	35
HOW TO: REMOVE BALL SENSOR .....	35
HOW TO: REMOVE CUP ASSEMBLY .....	36
HOW TO: ACCESS CAMERA/ LIGHT .....	36
PARTS LISTS .....	37-2
MAINTENANCE LOG .....	43
TECHNICAL SUPPORT .....	44
WARRANTY .....	45

# WELCOME TO: Sink It!

**Congratulations on your Sink It™ purchase!**

A family-friendly twist on our original Beer Pong Master game, Sink It is the perfect addition to any ticket redemption game room.

The fun ball-tossing action and competitive nature of Sink It will have players lining up!

Please take a moment to read through this manual and be sure to contact our factory if you have any questions or would like some more information.

Thank you for your purchase! Your business is important to us and we hope you enjoy this game as much as we do!

*Your Friends at Bay Tek Games*



## GAME INSPECTION

Inspect the game for any damaged, loose, or missing parts.

If damage is found, please contact your freight carrier first.

Then, contact Bay Tek Games' Service Department at 920.822.3951 or e-mail them at [service@baytekgames.com](mailto:service@baytekgames.com) for further assistance.

# HOW TO PLAY

Toss or bounce the balls into the targets in attempt to hit all 10 and turn off the blue lights inside!



The fewer shots you take, the more tickets you win!















# GAME SPECIFICATIONS

WEIGHT	
NET WEIGHT	475 LBS.
SHIP WEIGHT	525 LBS.
DIMENSIONS	
WIDTH	30"
DEPTH	71"
HEIGHT	77"
OPERATING TEMPERATURE	
FAHRENHEIT	80-100
CELSIUS	26.7-37.8

POWER REQUIREMENTS			
INPUT VOLTAGE RANGE	100 to 120 VAC	/	220 to 240 VAC
INPUT FREQUENCY RANGE	50 HZ	/	60 HZ
MAX START UP CURRENT		OPERATING CURRENT	
1 AMPS @ 115 VAC		1.5 AMPS @ 115 VAC	
0.5 AMPS @ 230 VAC		.75 AMPS @ 230 VAC	

# SAFETY PRECAUTIONS

 <b>NOTICE</b> 	
Modifications to the mechanical, electrical and structural components of this game may void its compliance certifications.	
This appliance is not suitable for installation in an area where a water jet could be used.	
 <b>DANGER</b> 	
DO NOT perform repairs or maintenance on this game with the power ON. Unplug the unit from the wall outlet or shut off the power strip located inside the cabinet.	
 <b>WARNING</b> 	
Use of flammable substances can cause sever burns or serious injury. Always use NON-FLAMMABLE solvents for cleaning. DO NOT use gasoline kerosene or thinners.	
 <b>CAUTION</b> 	
Lifting heavy objects can cause back, neck or other injuries. Be sure adequate lifting and moving devices are available when unloading, unpacking and moving this game.	
 <b>ATTENTION</b> 	
Be sure the electrical power matches the game requirements. See the serial number located on the back of the game cabinet. Always plug into a grounded circuit. If the supply cord is damaged, it must be replaced by an approved cord or assembly provided by the manufacturer.	
 <b>IN CASE OF EMERGENCY</b> 	
UNPLUG THE POWER CORD. The power cord must be accessible at all times in case of an emergency.	

# QUICK SET UP GUIDE

Place the game near its final location. Open the storage compartment by unlocking the front metal and sliding the bounce platform forward.



Ensure the balls didn't bounce out of the trough during transport.

No more than **20 balls** should be in the machine at a time for proper function

Sink It uses **38-40 mm** ping pong balls



Plug the power cord (located in the storage compartment) into the game and a standard 110v outlet, then switch the power strip inside the front door to the on position.



**The game may require a camera calibration after shipping. See page 15 for instructions.**

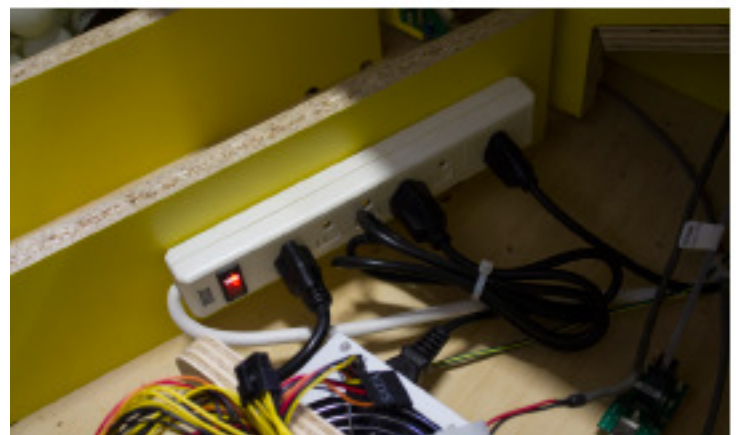

# DIP SWITCH SETTINGS

The dip switch bank is located on the minigen board under the bouncing platform; open the front door, then slide the platform towards you.

\*factory default settings are highlighted below

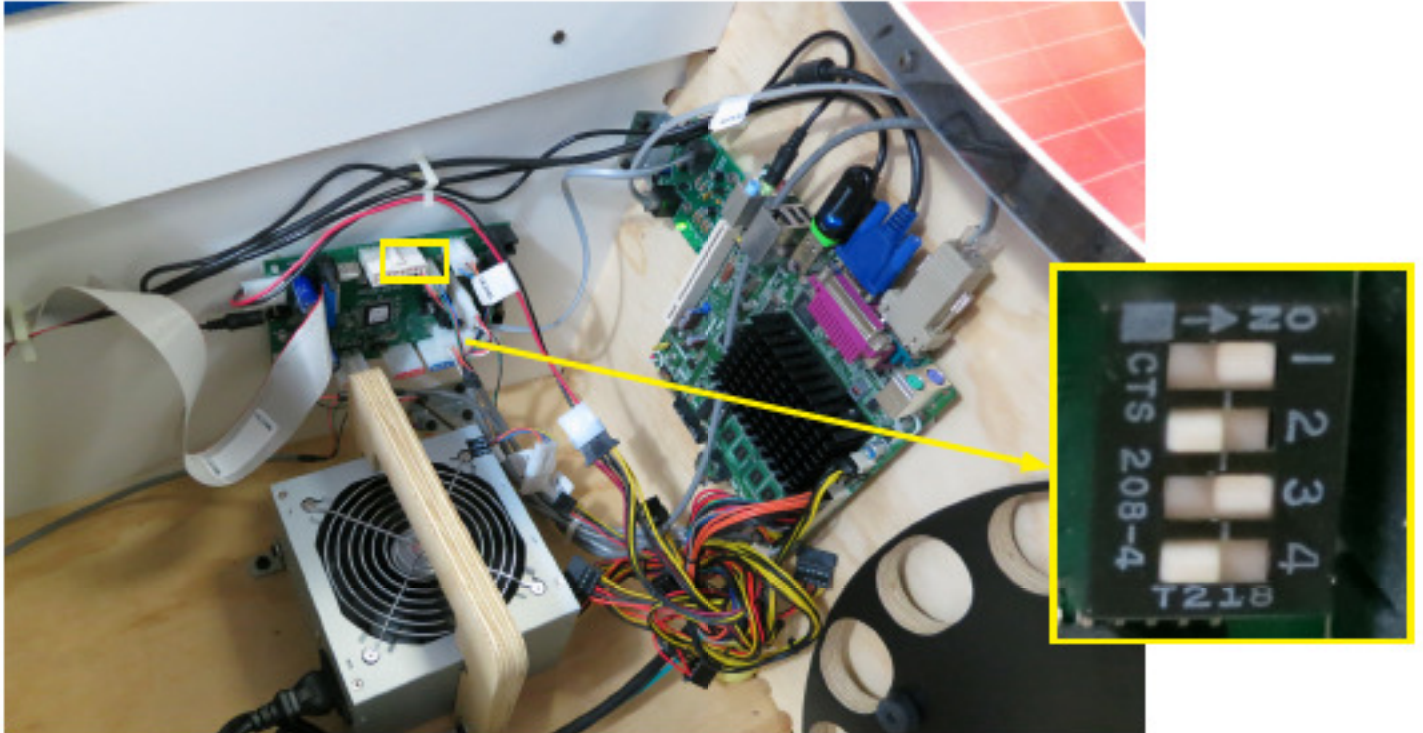

SWITCH	DESCRIPTION	OFF	ON
1	Enable Tickets		
2	New Jersey compliance		
3	Do Not Adjust		
4	Do Not Adjust		

## MAIN MENU

Press the **MENU BUTTON** inside the front door to enter the main menu.

Scroll through the options by pressing the **MENU BUTTON** and make your selection with the **MENU SELECT** button.

The blue and red player buttons also scroll through the menus.



### ***SINK IT Main Menu***

***Clear Credits & Tickets***

***Start Test Game after exit***

***Game Setup***

***Diagnostics Menu***

***Location Name and Advertising***

***Machine Setup***

***Reports***

***Software Update***

***Exit Menu***

***PC Software Version = 2.05.4***

***Minigen Software Version = 2.07***

***Camera Software Version = 1.23a***

### CLEAR CREDITS & TICKETS

Press MENU/SELECT when Clear Credits is highlighted to reset the available credits and tickets owed to 0.

### START TEST GAME AFTER EXIT

Selecting this option will start a test game after exiting the menu.

### CLEAR HIGH SCORES

Selecting this option will start clear the high scores screen.

# GAME SETUP

## **SINK IT Game Setup**

**Coins/Credits per Play** **4**  
**DBA \$1 Additional Games** **0 Games**  
**DBA \$5 Additional Games** **0 Games**  
**DBA \$10 Additional Games** **0 Games**  
**DBA \$20 Additional Games** **0 Games**  
**Credit Card Charge Games/Swipe** **Off**  
  
**Credit Add Games/Swipe** **0 Games**  
**Game Time** **60 Sec**  
**Balls per Game** **30 Balls**  
**Extra Last Ball Delay** **After 10 Sec**  
**Ticket Payout Pattern** **5**  
**# CUPS 0-3 4-6 7-9 All 10**  
**TICKETS 10 14 20 32 + balls left**  
**Divide Ticket Payout by 2** **Off**  
**Exit Menu**

SETTINGS OPTIONS & FACTORY DEFAULTS									
Credits per Play	0	1	2	3	4	5	6	7	8
DBA Additional Games	Gives additional games for \$ bill denominations (default is 0-off)								
CC Charge Games/Swipe	OFF					ON			
CC Add Games/Swipe	0	1	2	3	4	5	6	7	8
Game Time (seconds)	30	60	90	120	150	180			
Balls Per Game	10	20	30	40	50	60			
Extra Last Ball Delay (seconds)	never		10	15	20	25	30		
Ticket Patterns	see next page								
Divide Tickets by 2	OFF					ON (pays out 1 paper ticket per 2 tickets won)			

# TICKET PATTERNS

PATTERN	AVERAGE TICKETS PER GAME	NUMBER OF CUPS HIT			
		0-3	4-6	7-9	10
		TICKETS			
1	2-3	1	2	3	5
2	6-10	4	6	10	18 (+1 per remaining ball)
3	10-13	8	10	16	24 (+1 per remaining ball)
4	14-16	8	12	16	30 (+1 per remaining ball)
5	17-20	10	14	20	32 (+1 per remaining ball)
6	21-26	14	20	26	38 (+1 per remaining ball)
7	27-30	20	26	32	38 (+1 per remaining ball)
8	31-35	20	28	40	64 (+1 per remaining ball)
9	36-40	24	34	44	60 (+1 per remaining ball)
10	41-45	28	38	48	60 (+1 per remaining ball)
11	55-60	42	54	66	80 (+1 per remaining ball)
12	61-65	50	60	70	90 (+1 per remaining ball)
13	70-75	56	68	80	100 (+1 per remaining ball)
14	RAFFLE	0	0	0	1
FIXED TICKET PAYOUTS					
15		1			
16		2			
17		3			
18		4			
19		6			
20		8			
21		10			
22		15			
23		20			
24		25			
25		30			
26		50			

# DIAGNOSTICS MENU

## ***SINK IT Diagnostics Menu***

<b>Cup 1 target</b>	<b>OFF</b>	<b>Blue Button</b>	<b>OFF</b>
<b>Cup 2 target</b>	<b>OFF</b>	<b>Red Button</b>	<b>OFF</b>
<b>Cup 3 target</b>	<b>OFF</b>	<b>Coin Input</b>	<b>OFF</b>
<b>Cup 4 target</b>	<b>OFF</b>	<b>DBA Input</b>	<b>OFF</b>
<b>Cup 5 target</b>	<b>OFF</b>	<b>Ball Trough</b>	<b>OFF</b>
<b>Cup 6 target</b>	<b>OFF</b>	<b>Ball Release</b>	<b>OFF</b>
<b>Cup 7 target</b>	<b>OFF</b>	<b>Low Ticket</b>	<b>OFF</b>
<b>Cup 8 target</b>	<b>OFF</b>		
<b>Cup 9 target</b>	<b>OFF</b>		
<b>Cup 10 target</b>	<b>OFF</b>		
<b>Cheat Detect</b>	<b>OFF</b>		

**Dispense Ticket**  
**Ball Motor**  
**New background**  
**Camera Calibrate**  
**Exit Menu**

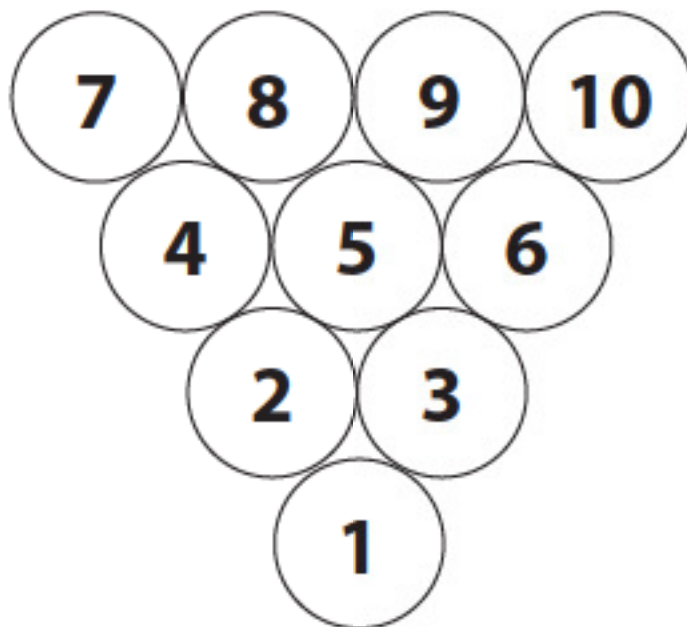
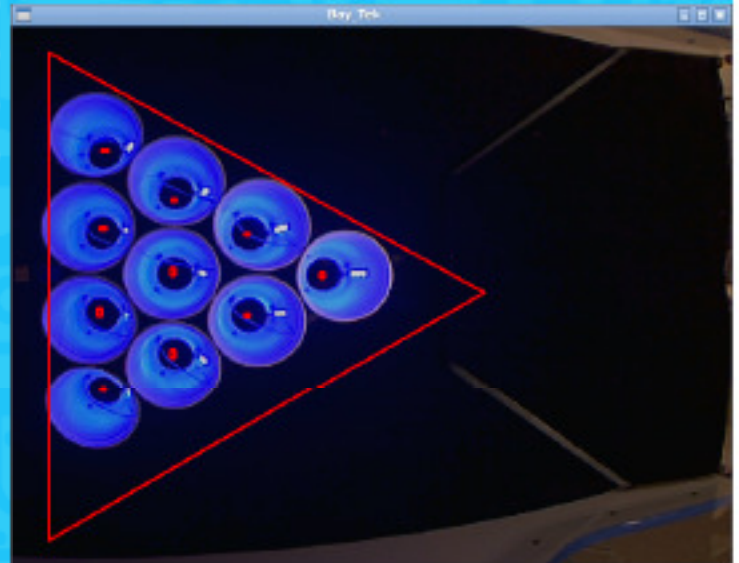

# MACHINE SETUP

## **SINK IT Machine Setup**

<b>Game Volume</b>	<b>5</b>
<b>Attract Volume</b>	<b>5</b>
<b>Attract Timing</b>	<b>1 min</b>
<b>Next Player Start Timeout</b>	<b>2 min</b>
<b>Timed Game Countdown Delay</b>	<b>15 sec</b>
<b>Cheat Detect Ends Game</b>	<b>3 warnings</b>
<b>Mech. Counter Advance</b>	<b>per Credit</b>
<b>Head 2 Head Machine ID</b>	<b>Off</b>
<b>H2H-Reg Game Select Delay</b>	<b>15 sec</b>
<b>H2H-Wait time 2nd Player</b>	<b>15 sec</b>
<b>H2H-Winner Extra Tickets</b>	<b>5</b>
<b>Demo Mode</b>	<b>Regular Play</b>
<b>Set Date/Time</b>	
<b>Exit Menu</b>	

### SETTINGS OPTIONS & FACTORY DEFAULTS

Game Volume	0	1	2	3	4	5	6	7	8	9	10	11	12
Attract Volume	0	1	2	3	4	5	6	7	8	9	10	11	12
Attract Timing	off		30 sec		1 min		5 min		10 min		15 min		
Next Player Start Timeout	off	30 sec		1 min		2 min		3 min		5 min			
Timed Game Countdown Delay	off	5 sec		10 sec		15 sec		20 sec		25 sec		30 sec	
Cheat Detect End Game	off	never end for cheat detection						1 warning		2 warnings		3 warnings	
Head to Head Machine ID	off					left (Player 1)				right (Player 2)			
H2H- Reg Game Select Delay	5 sec		10 sec		15 sec		20 sec		25 sec		30 sec		
H2H- Wait time 2nd Player	5 sec		10 sec		15 sec		20 sec		25 sec		30 sec		
H2H- Winner Extra Tickets	0	1	2	3	4	5	6	7	8	9	10		

# REPORTS MENU

## **SINK IT Report Menu**

**Earnings Report**  
**Tickets/Payout Report**  
**Exit Menu**

These reports will help you to determine the earnings, payout and overall number of plays generated by your Beer Pong game.

### **SINK IT Earnings Report** **Bay Tek Games 12-20-2013**

	<b>Percent Total</b>	<b>Number of Credits</b>	<b>Income</b>
<b>Bill Acceptor</b>	<b>0%</b>	<b>0</b>	<b>\$ 0.00</b>
<b>Credit Card</b>	<b>0%</b>	<b>0</b>	<b>\$ 0.00</b>
<b>Coins</b>	<b>0%</b>	<b>0</b>	<b>\$ 0.00</b>
<b>-----</b>			
<b>Total</b>		<b>0</b>	<b>\$ 0.00</b>
<b>0 Total Games Played</b>			

**Clear All Earnings Stats Press 3x**  
**Exit Menu**

### **SINK IT Ticket/Payout Rpt** **Bay Tek Games 12-20-2013**

<b>Cups Made</b>	<b>Balls Remaining</b>	<b>Tickets</b>	<b>Num Games</b>
<b>0-3</b>		<b>10</b>	<b>0</b>
<b>4-6</b>		<b>14</b>	<b>0</b>
<b>7-9</b>		<b>20</b>	<b>0</b>
<b>10</b>	<b>0-9</b>	<b>32-41</b>	<b>0</b>
<b>10</b>	<b>10-19</b>	<b>42-51</b>	<b>0</b>
<b>10</b>	<b>20+</b>	<b>52</b>	<b>0</b>
<b>-----</b>			
<b>TOTAL Tickets/Games</b>		<b>0</b>	<b>0</b>
<b>AVG Tickets/Game</b>		<b>0</b>	
<b>PAYOUT Percentage</b>		<b>0%</b>	

**Clear Ticket/Payout Stats Press 3x**  
**Exit Menu**

## SOFTWARE UPDATE

### ***SINK IT Software Upgrade***

***Update saving all settings Press 3x***

***Update to new rev settings***

***Restore previous version***

***Restart updated game***

***Reset Factory Settings***

***Exit Menu***

### ***NEW SW UPDATE VERSIONS:***

***PC Software Version = None***  
***Camera Software Version = None***

### ***CURRENT SW VERSIONS:***

***PC Software Version = 2.05.4***  
***Camera Software Version = 1.23a***

### ***BACKED UP SW VERSIONS:***

***PC Software Version = None***  
***Camera Software Version = None***



# MAINBOARD PINOUT GUIDE

Pin Type	Purpose	Ref	Pin #
LOWSIDE #1, w diode		J22	1
LOWSIDE #2, w diode		J22	2
LOWSIDE #3		J22	3
LOWSIDE #4		J22	4
LOWSIDE #5		J22	5
LOWSIDE #6		J22	6
LOWSIDE #7		J22	7
LOWSIDE #8		J22	8
LOWSIDE #9		J22	9
+12 Volts		J22	11
+12 Volts		J22	12
+12 Volts		J22	13
+12 Volts		J22	14
+12 Volts		J22	15
+12 Volts		J22	16

HIGHSIDE	Mechanical Count #1 Game	J25	1
HIGHSIDE	Mechanical Count #2 Ticket	J25	2
PX10	Service Button #1	J25	3
PX11	Service Button #2	J25	4
Ground	Ground for Service Buttons	J25	5
Ground	Ground for Mechanical Count #1 & # 2	J25	6
+12 Volts	Coin Door Power	J8	1
PA05	Coin Input	J8	2
Ground	Coin Ground	J8	3

=Low Side Driver			
=High Side Driver			
= TTL Input/Output			
= LED Constant Current Drive			
= 12 Volts			
= Ground			

Pin Type	Purpose	Ref	Pin #
Ground		J24	1
Ground		J24	2
+12 Volts		J24	3
+12 Volts		J24	4
PB7	Ball Dispense Sen-	J24	5
LOWSIDE #12	Select Red Light	J24	6
PX29	Ball Trough Sensor	J24	7
HIGHSIDE #10	Scroll Blue Light	J24	8
HIGHSIDE #11	Ball Release Dis-	J24	9
3.3V		J24	10

PX37	Ticket Notch #1	J5	1
Ground	Ground for Ticket	J5	2
PB18	Ticket Motor #1	J5	3
+12 Volts	Power for Ticket Dis-	J5	4

PB16	Low Ticket Switch	J9	1
Ground	Ground for Low Tick-	J9	2
PB17	Coin/DBA Lockout	J9	3
+12 Volts		J9	4

PA08	DBA Input	J8	1
+12 Volts		J8	2
Ground		J8	3
Ground		J8	4

# MAINBOARD PINOUT GUIDE

Pin Type	Purpose	Ref	Pin #
PB19		J21	1
PX39		J21	2
PX00		J21	3
PX01		J21	4
PB20		J21	5
PX02		J21	6
PB21		J21	7
PB22		J21	8
PB23		J21	9
PB24	Credit Card Reader Input	J21	10
Ground		J21	11
Ground		J21	12
Ground		J21	13
Ground		J21	14
+12 Volts		J21	15
+12 Volts		J21	16
+12 Volts		J21	17
+12 Volts		J21	18
PB25	Select Switch	J21	19
PB26	Game Start Switch	J21	20

Driver 1		J12	1
Driver 2		J12	2
+12 Volts		J12	3
Driver 3		J12	4
Driver 4		J12	5
+12 Volts		J12	6

Driver 5		J11	1
Driver 6		J11	2
+12 Volts		J11	3
Driver 7		J11	4
Driver 8		J11	5
+12 Volts		J11	6

Driver 9		J13	1
Driver 10		J13	2
+12 Volts		J13	3
Driver 11		J13	4
Driver 12		J13	5
+12 Volts		J13	6

Driver 13		J14	1
Driver 14		J14	2
+12 Volts		J14	3
Driver 15		J14	4
Driver 16		J14	5
+12 Volts		J14	6

=Low Side Driver
=High Side Driver
= TTL Input/Output
= LED Constant Current Drive
= 12 Volts
= Ground

Pin Type	Purpose	Ref	Pin #
+12 Volts		J29	1
+12 Volts		J29	2
+12 Volts		J29	3
PA21		J29	4
PA23		J29	5
PA22		J29	6
PA25		J29	7
PA24		J29	8
PA27		J29	9
PA26		J29	10
PC0		J29	11
PA28		J29	12
PX20		J29	13
PC1	Cup 1 Lights	J29	14
PX21	Cup 2 Lights	J29	15
PB0	Cup 3 Lights	J29	16
PX22	Cup 4 Lights	J29	17
PB1	Cup 5 Lights	J29	18
PX24	Cup 6 Lights	J29	19
PX23	Cup 7 Lights	J29	20
PX26	Cup 8 Lights	J29	21
PX25	Cup 9 Lights	J29	22
PX28	Cup 10 Lights	J29	23
Ground		J29	24
Ground		J29	25
Ground		J29	26

# MINIGEN PINOUT (AANEWGEN1-PJ/RBN)

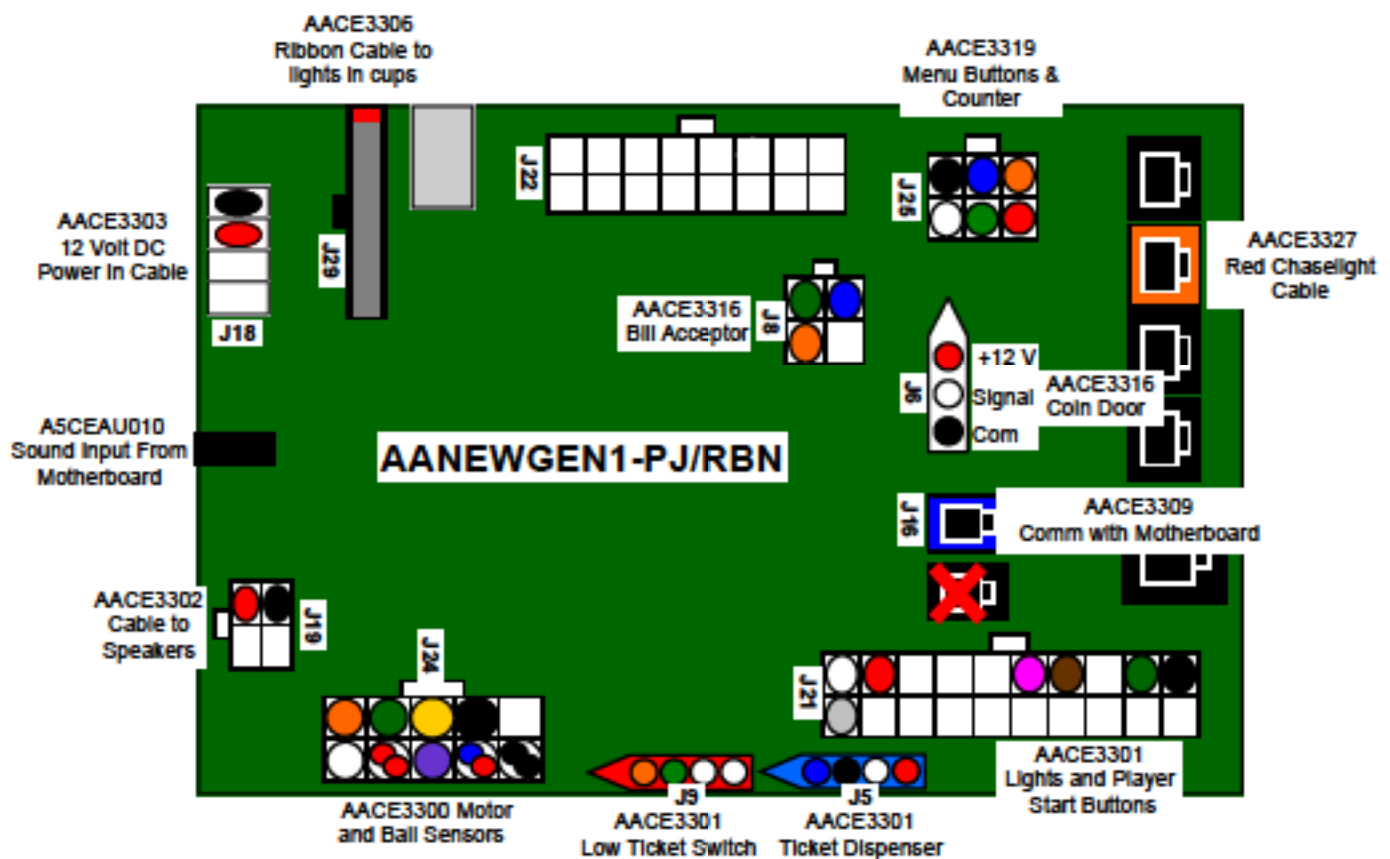

# WIRING DIAGRAMS

## COIN MECH, MENU BUTTON & COUNTERS

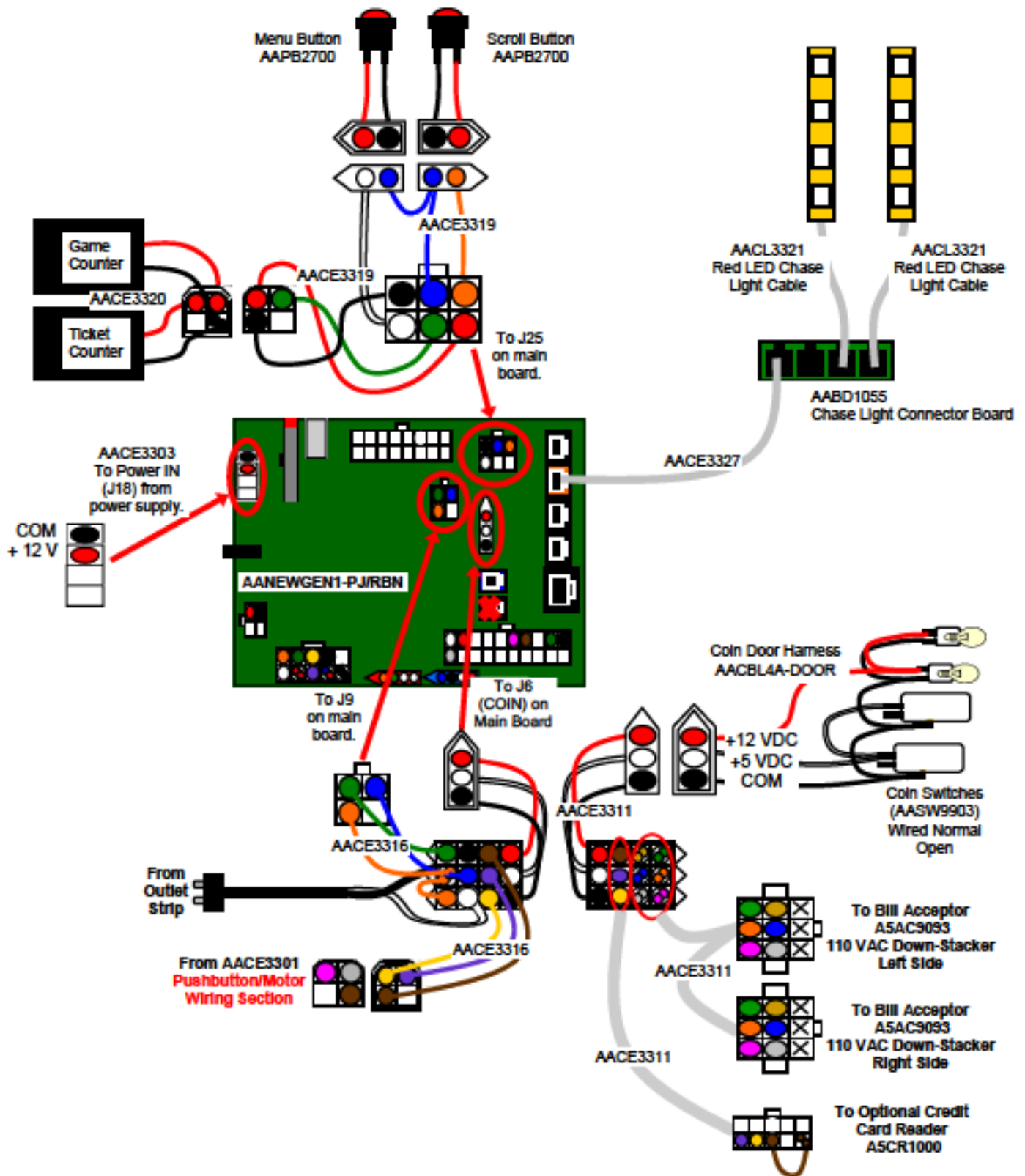

# WIRING DIAGRAMS

## PLAYER BUTTON, MOTOR & SENSORS

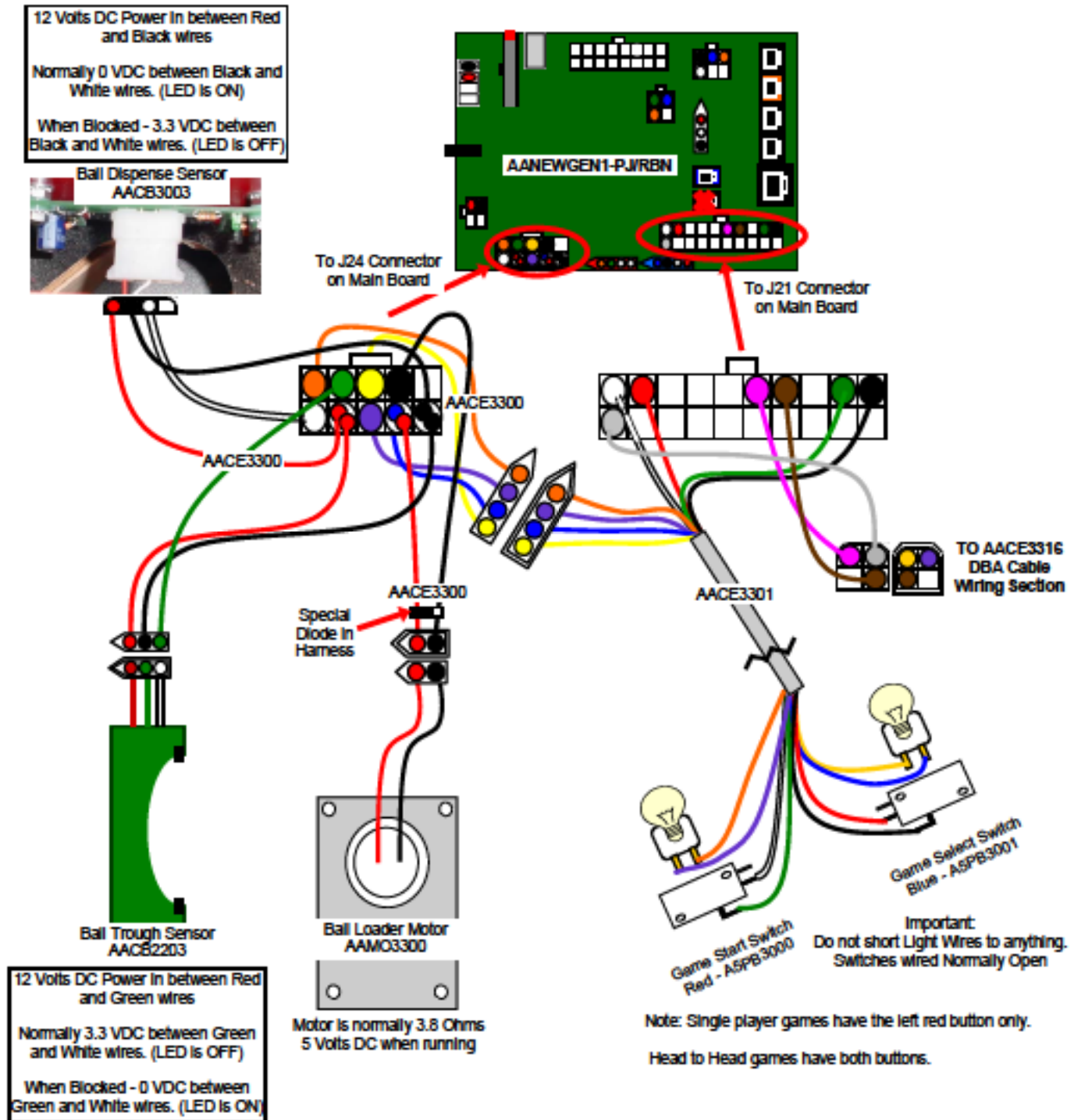

# WIRING DIAGRAMS

## MOTHERBOARD COMMUNICATION

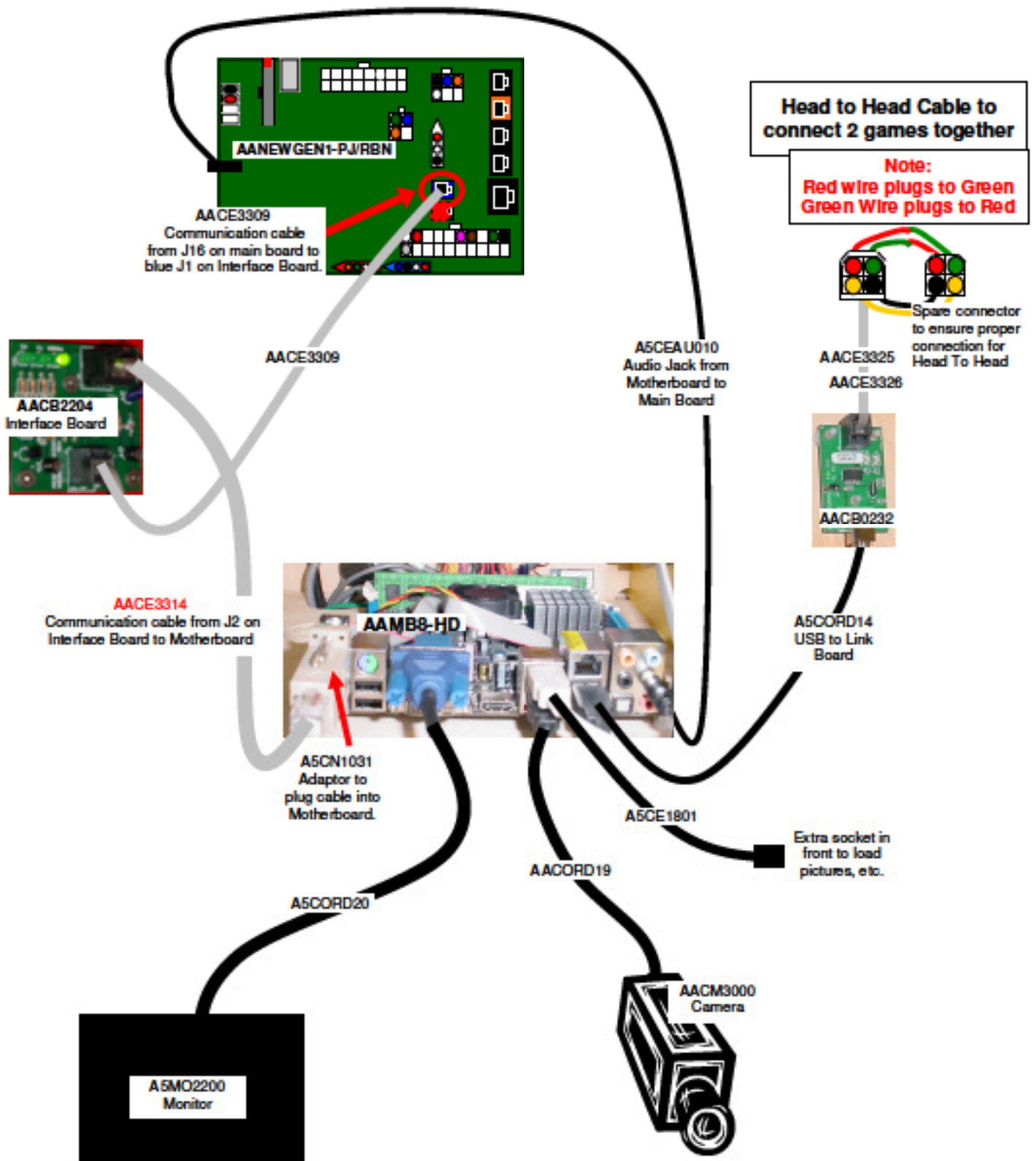

# WIRING DIAGRAMS

## CUP LIGHTS, TICKET DISPENSER & SPEAKER

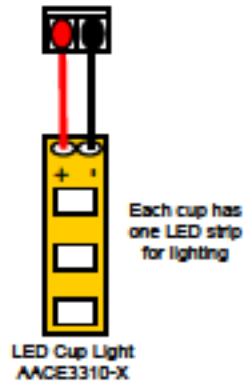
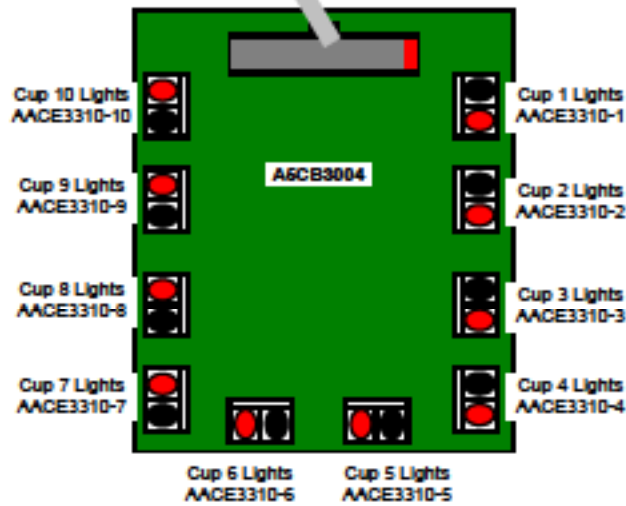
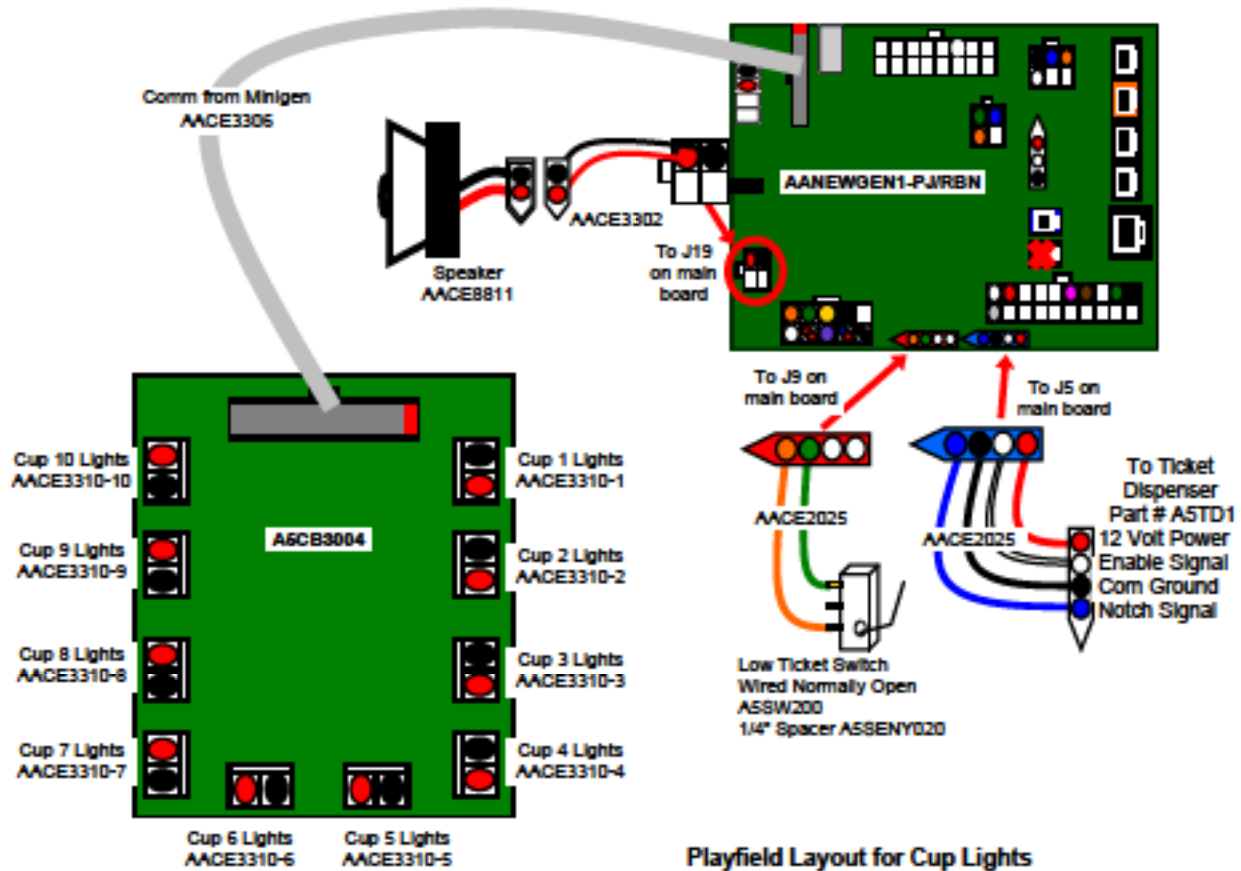

Playfield Layout for Cup Lights

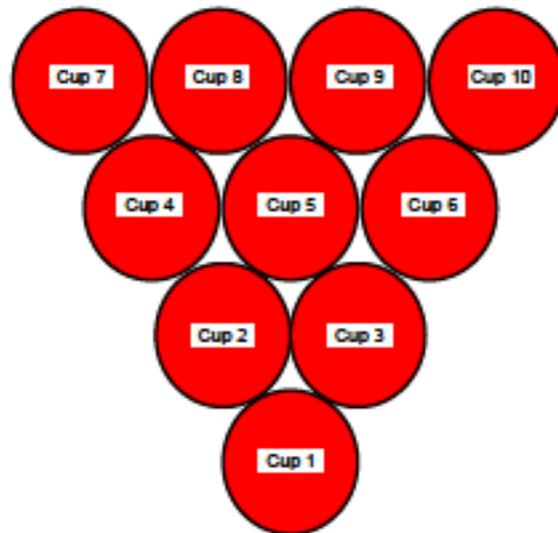

# WIRING DIAGRAMS

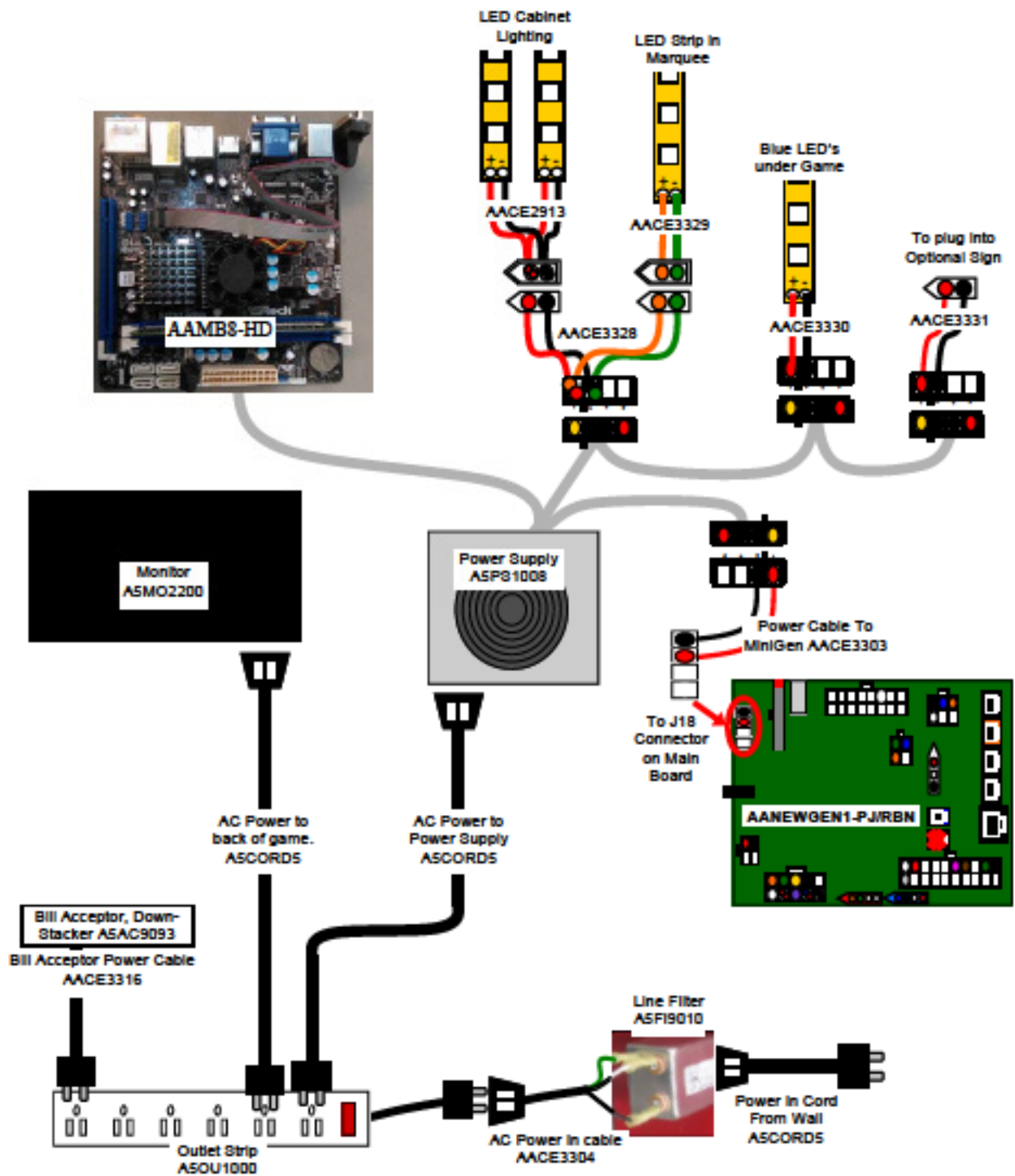

## A/C IN & POWER SUPPLY



# TROUBLESHOOTING GUIDE

## Troubleshooting Strategy

Use common sense and a systematic method of troubleshooting to determine the exact problem, probable cause and remedy. Use the process of elimination to find the faulty component. Always check for the simple and obvious causes first such as unplugged, loose or broken wires and bad sensors, bent, pinched, stuck or jammed components.

Troubleshooting Chart		
Problem	Probable Cause	Remedy
<p>No power to the game. No lights on at all.</p>	<p>Unplugged. Circuit breaker tripped. Line Filter Faulty. Power strip faulty. Faulty cable/power supply.</p>	<p>Check wall outlet. Reset power strip breaker switch or building circuit breaker. Replace Line Filter (Part # A5FI9010) Change plug position, replace if needed. See Power Supply diagnostic below.</p>
<p>Bill Acceptor on. But everything else off.  (Power Supply not ON)</p>	<p>Power supply unplugged. Rocker Switch.  Power supply shutting down because of 12 V overload.  Faulty power supply.</p>	<p>Insure unit is plugged into power strip. Make sure rocker switch is set ON.   See power supply diagnostics to isolate bad component. A bad motor or 12 volt short would cause this. See Power Supply Diagnostic below.</p>
<p>Dollar Bill Acceptor not functioning.  Ensure Bill Acceptor is set to "Always Enable"  <b>Important : Only 110 Volt AC DBA is to be installed.</b>  Enter Diagnostic Menu to see if DBA input flashes ON quickly when bill is inserted.</p> 	<p>Look for "Check Minigen Comm" error on screen. Check for power to Bill Acceptor. Dirt or debris in acceptor slot.  Pinched, broken, or disconnected wiring.  Bill acceptor problem. Part # A5AC9093 110 VAC Downstacker</p>	<p>Refer to "Check Minigen Comm" error diagnostic section. Acceptor should cycle stacker at game power up. If not, check cable connections. Refer to "How to Clean Bill Acceptor" Or clean with bill reader cleaning card. (A5CC9000) Check wiring from bill acceptor to Mini Gen Board. (AACE3316, AACE3311) Repair or replace wiring harness. Check J9 connector on Main Board Make sure wires are secure in connectors. Refer to troubleshooting section of dollar bill acceptor manual included with this game or the diagnostics label of the back of the unit.</p>
<p>Meters does not work. Game/Credit meter has option in menu to click as each coin is inserted or click as each game is started. Ticket meter will click as tickets come out of game and notch is "seen" by dispenser.</p>	<p>Ensure correct number of tickets are being dispensed. Disconnected, loose or broken wires.  Faulty counter.</p>	<p>Check ticket values. Refer to Tickets not dispensing troubleshooting section. Check connections and reseal J25 on Minigen board. Cables # AACE3319 and AACE3320 Replace counter. AACE3320</p>

# TROUBLESHOOTING GUIDE

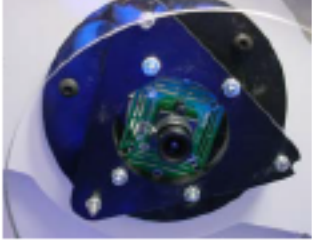
Problem	Probable Cause	Remedy
<b>Scoring Incorrectly</b> 	<p>All scoring is registered with a camera in top of cabinet.</p> <p>It is OK if camera is mounted on angle.</p> <p>Enter Diagnostic Menu to see "live" view of camera</p>	<p>If no camera picture in Diagnostic Menu: Check:</p> <p>Camera (Part # AACM1300)            Cable (Part # AACORD19)            USB connection at motherboard            Replace motherboard. (Part # AAMB8-HD)</p>

## How to Calibrate Camera

- 1.) Enter Diagnostic Menu to see "live" view of camera.
- Verify all cups are within triangle pattern shown on monitor.
  - Verify squares are aligned with the holes in bottom of cups.
  - All cup targets should read "OFF" when camera is aligned.

To fix any problems:

- Step # 1: Scroll down and select "New background"  
 Step #2: Scroll down and select "Camera Calibration".  
 This will reset the image.



**Note: When camera is properly calibrated, the red dots will be in center of black holes in bottom of cups as shown.**

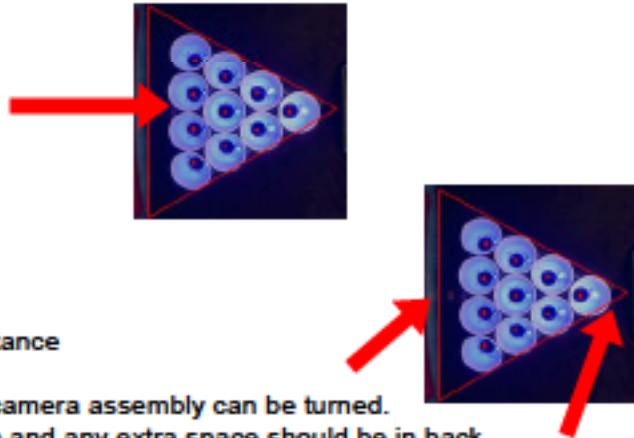

If problem still exists:

- Ensure camera is secure in game.
- Ensure cup assembly is positioned correctly.
- Check connections from camera to motherboard.

The camera is installed in it's housing to ensure correct distance and alignment with the cup assembly.







If camera itself had been misadjusted, then the screws on camera assembly can be turned.

Notice red triangle overlay should be very close to front cup and any extra space should be in back.



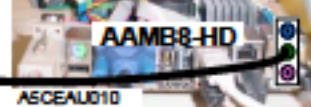

- 2.) Toss balls into each cup and verify that the corresponding "Cup target" flashes to ON in the diagnostic screen.

<b>Cup Lights not working</b>	All Cup light stay ON or stay OFF.	Make sure balls are scoring. Playfield Aux Board faulty. (A5CB3004) Cable to Minigen faulty. (AACE3306) Faulty Minigen board. (AANEWGEN1-PJ/RBN)
	Individual cup lights not working	Faulty LED light strip inside cup. (AACE3310-X) Playfield Aux Board faulty. (A5CB3004)







# TROUBLESHOOTING GUIDE

Problem	Probable Cause	Remedy
<p>Game not coining up.</p> <p>Note: If game is equipped with 2 Bill Acceptors, they both share the signal line to Mini Gen Board to Connector J9</p> <p>Enter Diagnostic Menu to see if Coin input goes to ON quickly when coin is inserted.</p> 	<p>Look for "Check Minigen Comm" error on screen.</p> <p>Ensure game makes sound when coin switch is triggered.</p> <p>Game set to large amount of credits per game.</p>	<p>Refer to "Check Minigen Comm" error diagnostic section.</p> <p>Check coin switches—both should be wired normally open. If one switch is "closed" the other will not work either.</p> <p>Check wiring to Mini Gen Board. (AACBL4A-DOOR, AACE3316, AACE3311)</p> <p>Check Game Setup Menu. Ensure Coins/ Credits per Game is set. Default = 4.</p>
<p>No Sound</p> <p>Motherboard creates sound, AACB1800 board amplifies it.</p>   	<p>Volume set to zero in menu.</p> <p>Disconnected, loose or broken wires.</p> <p>Determine if MiniGen board is good.</p> <p>Faulty speaker.</p>	<p>Enter Machine Setup Menu and verify: Game Volume &amp; Attract Volume is not zero</p> <p>Check connections and reseat audio cable from motherboard to MiniGen board. Cables # AACE8811, AACE3302, and A5CEAU010.</p> <p>Unplug audio jack cable (A5CEAU010) from motherboard, plug into MP3 player and see if music is amplified and comes out of speaker.</p> <p>If Yes - then motherboard is faulty.</p> <p>If No - then Minigen may be faulty.</p> <p>Replace speaker. AACE8811</p>
<p>Check Minigen Comm Error</p> <p>Game does not coin up but credit meter clicks.</p> 	<p>Main Board and wiring to coin switch OK.</p> <p>Check green LED's on Serial Interface board.</p> <p>Is "Power" solid ON?</p> <p>Is "TX" &amp; "RX" blinking very fast?</p> 	<p>If "Power" is not solid ON</p> <p>Ensure AACE3309 cable is plugged into blue "IN" socket on main board. (J16)</p> <p>Replace if needed.</p> <p>Replace Serial Interface board. (AACB2204)</p> 
		<p>If "TX" &amp; "RX" are not blinking very fast</p> <p>Communication to Motherboard faulty.</p> <p>Check AACE3314 to motherboard.</p> <p>Check or replace adaptor (A5CN1031)</p> 





# TROUBLESHOOTING GUIDE

Problem	Probable Cause	Remedy
<b>Balls not releasing</b>	- There are many factors that could contribute to the balls not releasing. Please browse through the following sections: - Not enough balls in game - Ball jam - Error on screen - Faulty Motor - Ball release sensor blocked/bad - Ball trough sensor blocked/bad	
<b>Not enough balls in game</b>	Add balls (Part # A5BA3001) 38-40 mm ball size	Game should have 20 balls in it.  Too many is bad - they may block a sensor
<b>Ball jam</b>	Too many balls in game.	Game should have only 20 balls in it. If balls stack up and block sensor boards, it will not release balls.
	Ball release sensor causing motor to pause.  	If ball release sensor is blocked, it will stop motor until the blockage is cleared.  Ball Jam message will appear on screen: 
	Physical blockage in game.	Inspect ball path and ensure no debris is blocking balls.
<b>Error on screen</b> 	If game detects a ball blocking the ball release sensor, it will power off motor to avoid damage to motor.	Remove jam from sensor. Refer to "Ball Release Sensor Blocked/Bad" section.
<b>Faulty Motor</b> 	Check for blocked Ball Release sensor.	Unplug Ball Release sensor to see if motor starts working again.
	Disconnected, loose or broken wires.	Check connections from motor to Minigen board. (Cable # AACE3300, AAMO3300)
	Faulty motor.	Check for 3.8 Ohms across motor leads. Check for 5 Volts DC when running. Replace motor. (Part # AAMO3300)
	Faulty Minigen Board	If 0 volts when motor should be running, Minigen board may be bad. (Part # AANEWGEN1-PJ/RBN)

# TROUBLESHOOTING GUIDE

Problem	Probable Cause	Remedy
<p><b>Balls not releasing</b> - There are many factors that could contribute to the balls not releasing. Please browse through the following sections:</p> <ul style="list-style-type: none"> <li>- <b>Not enough balls in game</b></li> <li>- <b>Ball jam</b></li> <li>- <b>Error on screen</b></li> <li>- <b>Faulty Motor</b></li> <li>- <b>Ball release sensor blocked/bad</b></li> <li>- <b>Ball trough sensor blocked/bad</b></li> </ul>		
<p><b>Ball release sensor blocked/bad</b></p> 	<p>Too many balls in game blocking sensor, software will stop motor to prevent damage "Ball Jam—See Attendant" will show on screen</p> <p>Check voltage with DC Multi-meter</p>  <p>Disconnected, loose or broken wires.</p> <p>Enter Diagnostic Menu to see if game recognizes sensor.</p> <p>Faulty sensor.</p>	<p>Game should have only 20 balls, if there are too many balls, they will back up and block sensor, turning off motor.</p> <p>Check power: 12 Volts DC Power In between Red and Black wire Normally 0 VDC between Black and White wires. (LED is ON) When Blocked - 3.3 VDC between Black and White wires. (LED is OFF)</p> <p>Check connections from sensor to Minigen board. Cable # (AACE3300)</p> <p>Ball Release should go to ON when sensor is blocked. </p> <p>Replace sensor. (Part # AACB3003)</p>
<p><b>Ball trough sensor blocked/bad</b></p> 	<p>If ball trough sensor does not see balls played, game will not release more balls.</p> <p>Check voltage with DC Multi-meter</p>  <p>Disconnected, loose or broken wires.</p> <p>Enter Diagnostic Menu to see if game recognizes sensor.</p> <p>Faulty sensor.</p>	<p>Ensure ball trough is clear and not blocked with debris.</p> <p>Check power: 12 Volts DC Power In between Red and Green wire. Normally 3.3 VDC between Green and White wires. (LED is OFF) When Blocked - 0 VDC between Green and White wires. (LED is ON)</p> <p>Check connections from sensor to Minigen board. Cable # (AACE3300)</p> <p>Ball Trough should go to ON when sensor is blocked. </p> <p>Replace sensor. (Part # AACB2203)</p>









# TROUBLESHOOTING GUIDE

Problem	Probable Cause	Remedy
<p><b>Not counting balls</b></p> 	<p>Any balls missing the cups will be counted by the Ball Trough Sensor</p> <p>Check voltage with DC Multi-meter</p> <p>Disconnected, loose or broken wires.</p> <p>Enter Diagnostic Menu to see if game recognizes sensor.</p> <p>Faulty sensor.</p>	<p>Ensure ball trough is clear and not blocked with debris.</p> <p>Check power: 12 Volts DC Power In between Red and Green wire. Normally 3.3 VDC between Green and White wires. (LED is OFF) When Blocked - 0 VDC between Green and White wires. (LED is ON)</p> <p>Check connections from sensor to Minigen board. Cable # (AACE3300)</p> <p>Ball Trough should go to ON when sensor is blocked.</p>  <p>Replace sensor. (Part # AACB2203)</p>
<p><b>Counting too many balls</b></p>	<p>Ball Trough Sensor is "seeing" too many balls pass through.</p>	<p>Test with finger to ensure LED goes ON.</p> <p>If LED is dim all the time, sensor is bad.</p> <p>Replace sensor. (Part # AACB2203)</p>
<p><b>Buttons do not work.</b></p>  <p>Note: Single player games have the red button only. Head to Head games have both buttons.</p>	<p>Button stuck, sticky or broken.</p> <p>Disconnected, loose or broken wires.</p> <p>Enter Diagnostic Menu to see if game recognizes button.</p> <p>Faulty button.</p>	<p>Clean top of button, ensure it springs back when pushed down. Look for broken tab on bottom of switch.</p> <p>Check connections from switch to Minigen board. (Cable # AACE3301)</p> <p>Button should go to ON when button is pushed.</p>  <p>Replace button. A5PB3000 for Red. A5PB3001 for Blue.</p>
<p><b>Button lights do not work.</b></p>  <p>Note: Single player games have the red button only. Head to Head games have both buttons.</p>	<p>Light bulb itself burned out.</p> <p>Disconnected, loose or broken wires.</p> <p>Faulty button.</p>	<p>Check for 12 Volts DC across lights: Purple and Orange for Red Light Blue and Yellow for Blue Light</p> <p>Check connections from switch to Minigen board. (Cable # AACE3301)</p> <p>Replace button. A5PB3000 for Red. A5PB3001 for Blue.</p>

# TROUBLESHOOTING GUIDE

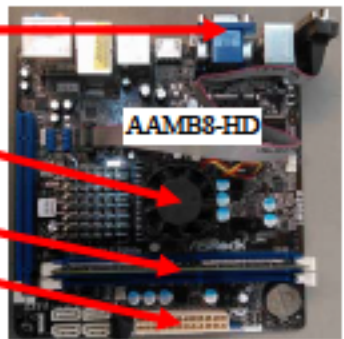
<p>Tickets do not dispense or Wrong amount dispensed.</p> <p>Make sure Dip # 1 ON on Minigen</p> <p>Check for the correct amount of tickets showing on Monitor</p>	<p>Tickets on monitor does not match tickets coming out of game.</p>	<p>Opto Sensor on ticket dispenser dirty.</p> <p>Faulty ticket dispenser.</p> <p>Notch on tickets cut too shallow.</p> <p>Faulty cable. Disconnected, loose or broken wires.</p> <p>Faulty Main Board.</p>	<p>Blow dust from sensor and clean with isopropyl alcohol.</p> <p>Replace with working dispenser to isolate the problem. (A5TD1)</p> <p>Flip tickets and load upside-down to have large cut notch toward opto sensor.</p> <p>Check connectors from ticket dispensers to MiniGen board. Check for continuity. Cables AACE2025</p> <p>Replace MiniGen board(AANEWGEN1-PJ/RBN)</p>
	<p>Tickets on monitor does match tickets coming out of game.</p>	<p>Settings in Menu are incorrect.</p> <p>Camera not seeing ball correctly.</p>	<p>Enter Menu and check certain areas: Divide Tickets By 2 Ticket Patterns H2H-Winner extra tickets</p> <p>Refer to "Ball Scores incorrectly" section.</p>
<p>Low Tickets message on monitor</p>	<p>Tickets are empty in ticket tray</p> <p>Faulty cable. Disconnected, loose or broken wires.</p> <p>Faulty low ticket switch.</p> <p>Faulty MiniGen Board</p>	<p>Load tickets into tray. Ensure tickets hold down micro switch wire.</p> <p>Check connectors from low ticket switches to MiniGen board. Check for continuity. (AACE2025)</p> <p>Inspect switch and replace if needed. (AASW200)</p> <p>Replace Minigen Board. (AANEWGEN1-PJ/RBN)</p>	
<p>Head to Head Linking Issues</p> 	<p>Games are linked using a USB cable from the motherboard to a Link Board (part # AACB0232) A cable (AACE3325) will then be connected to the next game. It will connect to cable # AACE3326 from other game.</p> <p>Ensure Machine ID is set to different values: One game must be set to "Left" Other game must be set to "Right"</p> <p>Two LED's will flash when communication is established.</p> <p>If not flashing when connected, problem may be: - USB cable to Link Board (part # A5CORD14) - Link Board (part # AACB0232) - Comm cable to other game (AACE3225 or AACE3326)</p> <p>If flashing when connected, then the problem is in these menu selections of either game.</p> <div data-bbox="1015 1407 1502 1764" style="background-color: #e0f0ff; padding: 5px;"> <p><b>SINK IT Machine Setup</b></p> <p>Game Volume 5              Attract Volume 5              Attract Timing 1 min              Next Player Start Timeout 2 min              Timed Game Countdown Delay 15 sec              Cheat Detect Ends Game 3 warnings              Mech. Counter Advance per Credit</p> <p><b>Head 2 Head Machine ID</b> Off              H2H-Reg Game Select Delay 15 sec              H2H-Wait time 2nd Player 15 sec              H2H-Winner Extra Tickets 5              Demo Mode Regular Play              Set Date/Time              Exit Menu</p> </div>		

# TROUBLESHOOTING GUIDE

Problem	Probable Cause	Remedy
<p><b>Monitor not working.</b></p> <p>Power down, wait 10 seconds and power up again.</p>	<p>Monitor says "NO SIGNAL" for 5 seconds after power-up. Then dark.</p>	<p>Monitor VGA cable unplugged. </p> <p>Fan on motherboard not turning </p> <p>Faulty or loose RAM </p> <p>Large power connector unplugged on motherboard </p> <p>Faulty power supply - Refer to Power Supply/Motherboard diagnostic section</p> <p>Faulty motherboard - Replace faulty board. (AAMB8-HD) </p>
<p>Monitor has nothing at all on power up.</p>	<p>Power cable unplugged from monitor.</p> <p>Faulty monitor.</p>	<p>Ensure power is plugged into back of monitor, down to power strip.</p> <p>Replace monitor. (A5MO2200)</p>
<p>Error on screen at power up.</p> <p>Re-Boot game to see if problem still exists.</p>	<p>Display shows "Puppy Video Wizard" or "Xorg"</p> <p>Display shows "Kernel panic – unable to mount root"</p> <p>Display shows "ASROCK Setup Utility Menu"</p>  <p>Display shows "Ubuntu—Check drive for errors"</p>	<p>Game is not recognizing monitor. Ensure VGA cable is secure to I/O board. Replace monitor. (A5MO2200)</p> <p>Faulty or loose RAM, faulty software, faulty motherboard</p> <p>No SATA drive in motherboard. Check for power connector </p> <p>Plug in keyboard and press the "F" key. It will check drive for errors and start game</p>
<p><b>Monitor problems</b></p> <p>Blurry Monitor</p> <p>Too bright, or dim.</p> 	<p>Open back door of cabinet. Monitor will swing out on door. Menu buttons are located on bottom right edge of monitor, partially hidden by clear plexi of monitor.</p> <p>Press the far left button (Auto) to select Auto Adjustment. This may take a few seconds.</p> <p>Verify that the screen looks good and image is centered.</p>	

# POWER SUPPLY DIAGNOSTICS

- 1.) Verify AC power to game. Check power strip in front door.

The rocker switch should be illuminated.



- 3.) Check connection to power supply.
- 4.) Ensure Power Supply switch is set to 115V (or 230V)  
(Some model power supplies may not have this)
- 5.) Ensure Power switch is on.



- 6.) Ensure fan is turning.
  - If power supply fan is turning and there is no 12 Volt out, then replace power supply. (A5PS1008)
  - If power supply fan is not turning, then continue to "Verify Power to Motherboard"

## Verify Power to Motherboard

The motherboard will turn on power supply.

If your game has no 12 volts, it may be the motherboard not turning on.

In addition - there may be a 12 volt short somewhere else in cabinet that is not allowing the power supply to turn on.

## Minimize load on power supply and isolate short

Unplug all outputs from power supply except for motherboard.

This will have power supply, motherboard, and monitor left plugged in.

If power supply, motherboard, and monitor now turn on:

Plug in one component at a time to power supply to locate short.

If power supply still does not power on, then continue to steps 1,2, and 3.

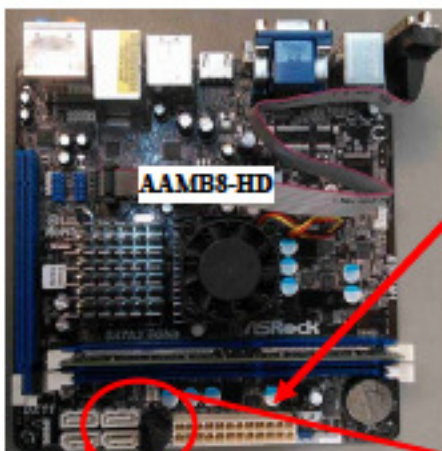

- 1 - Check single connection from power supply.

- 2 - Verify these pins are covered by connector with a single capacitor.

If the connector is missing, continue to step 3 to jump the pins under this connector.

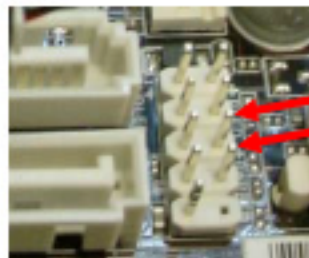
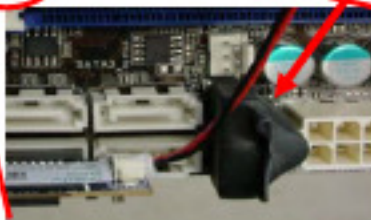

- 3 - Motherboard "Jump Start"

As a last resort, you may start motherboard by quickly touching these 2 pins at the same time, then quickly release

Motherboard may turn ON and boot normally.

If power supply still does not power on, replace power supply (A5PS1008), replace motherboard. (AAMB8-HD)

# BILL ACCEPTOR DIAGNOSTICS

**Note:** There are many different models and brands of Bill Acceptors that are used on redemption games. Your Bill Acceptor may differ from the unit shown. A "Downstacker" should be used for clearance issues. Standard DBA is MEI # AE2431-D5E Part # A5AC9093

Determine if Bill Acceptor has power:

Turn game ON—The bill acceptor should make noise as stacker cycles and green lights on outside bezel should flash.

If NO power:

Use meter to measure 110 AC voltage at cable going into Bill Acceptor from power strip.

If power is OK:

Clean Bill Acceptor path to make sure there is nothing jamming unit. Check dipswitch settings on side of acceptor.

**Make sure switch # 8 is OFF for Always Enable**



## ERROR CODES

Count the number of flashes on front bezel of Bill Acceptor and follow chart for repair.

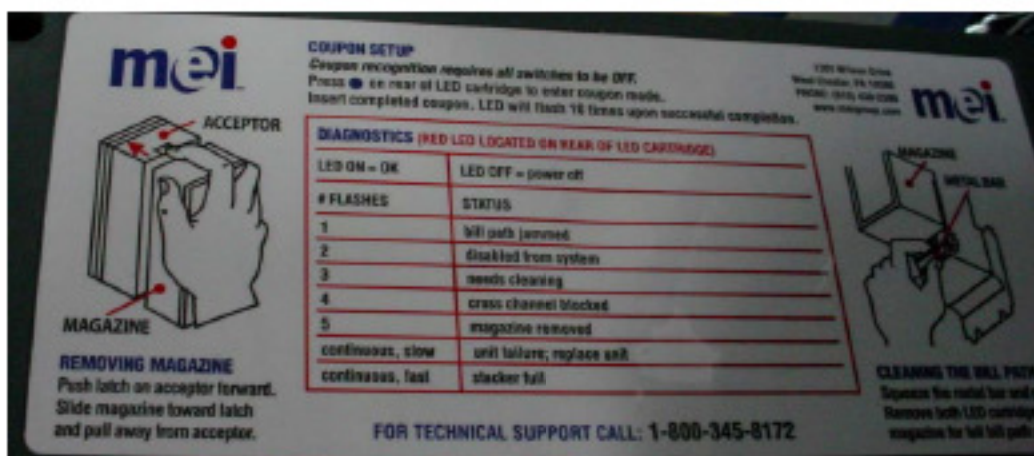

## HOW TO: ACCESS MAINBOARD/ MOTOR/ BALL SENSOR



Unlock 2 top locks and flip open front panel.



Slide "Bounce Pad" out toward front of game.



Motherboard, Power Supply, Minigen board and Communication board are now accessible.

### To Remove Motor:

Remove 4 screws from center of wood wheel.

Motor can now be unscrewed and removed from game.



### To Remove Ball Trough Sensor:

Remove 2 screws from brackets on both sides of the cabinet and remove carpeted wood platform.



Remove screws from brackets holding vertical wood that sensor is mounted to.

Lift wood out of cabinet, unplug sensor, and remove sensor.



## HOW TO: REMOVE CUP ASSEMBLY

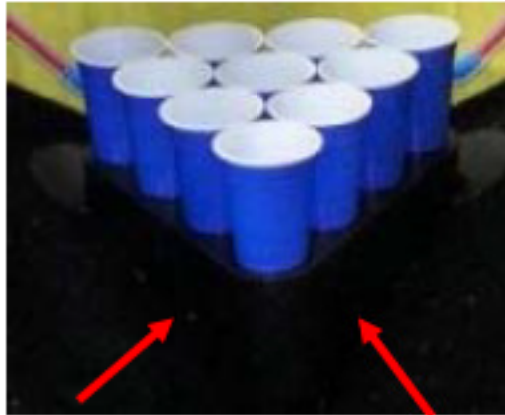

Remove 2 screws holding cup platform in place.

## HOW TO: ACCESS CAMERA/ AC LIGHT

Remove 3 screws holding wood support in place.

Slide plexi toward front of cabinet and remove from game.



### **Note on linking two Sink It Games:**

Two Sink It games can be linked for Head To Head play.

The conversion kit is part # AAKIT-SI

The marquee sign is part # AASIGN-SI

Games are linked using a USB cable from the motherboard to a Link Board (part # AACB0232) and then a cable out to a similar cable from the next game.

Menu selections must also be changed to designate games.



# PARTS LIST

PART #	DESCRIPTION	PART #	DESCRIPTION
A5PL0097	Plate, replaces the bill acceptor	A5PL3050	Plug, Push In, Round, 1" Hole
A5BA3001	Ball, White, Ping Pong Ball, 40 mm	A5PL9991	Plate, Ticket Option, Blue
AABA3001-P40	Pre-packaged bag of 40 balls	A5OU1000	Outlet Strip AC
A5CA1002	Wheel Casters	A5PB3000	Pushbutton, Start, Red
A5VF2002	Con Box, Black Plastic	A5PB3001	Pushbutton, Select, Blue
A5CE1801	Cable, USB, 3 foot to Front of game	AAPB2700	Pushbutton, Menu buttons
A5CEAU010	Cable, Audio Stereo	AACE2025	Cable, Ticket Dispenser
A5CN1031	Adapter (RJ45) for Motherboard	AACE3300	Cable, Minigen to Sensors & Ball Motor
AACORD19	Camera Cable	AACE3301	Cable, Main Door, Buttons
A5CORD20	Cable, 10' SVGA Monitor Cable	AACE3302	Cable, Volume/Speakers
A5CORD5	AC Power Cord	AACE3303	Cable, Minigen Power In Cable from PS
AACU3001-10	Cup, Solo, Blue 18 Oz, 10 Cups w/ holes	AACE3304	Cable, Line Filter Cable
AACU3010	Playfield Cup Assy	AACE3306	Cable, Ribbon from Minigen to AUX Board
A5DE3050	Marquee Back Plexi	AACE3309	Cable, Minigen to Interface Comm
A5DE3050-1	Marquee Front Plexi	AACE3310-1	Cable, Playfield Cup Light
AADE3050	Marquee Faceplate Assy	AACE3311	Cable, Dual DBA Cable
A5DE3051	Decal, Bounce Pad	AACE3314	Cable, Interface to Motherboard Comm
A5DE3052	Decal, Back Wall	AACE3316	Cable, DBA Cable
A5DE3053	Decal, Front Cabinet Decal	AACE3318	Cable, Grounding Wire
A5DE3054-1	Decal, Right Side Front	AACE3319	Cable, Jumper to Counters/Menu Buttons
A5DE3054-2	Decal, Right Side Middle	AACE3320	Counter Assembly
A5DE3055-3	Decal, Right Side Top Seam	AACE3321	Cable, Chase Light, Rail
A5DE3055-1	Decal, Left Side Front	AACE3327	Cable, Minigen to Chase Light Jumper BD
A5DE3055-2	Decal, Left Side Middle	AACE3328	Cable, 12V to Marquee Lighting
A5DE3055-3	Decal, Left Side Top Seam	AACE3329	Cable, LED Strip in Marquee
A5DE3057	Decal, Control Panel, Left Side	AACE3330	Cable, Blue LED's under game
A5DE3058-1	Decal, Control Panel, Right Side	AACE3331	Cable, 12V to optional Sign
A5DE3059	Decal, Tickets Here Decal	AACBL4A-DOOR	Cable, Coin Mech
A5DE3060	Decal Set, Ticket Pattern Set		
		A5SW200	Low Ticket Switch
A5FI9010	Line Filter , Power In	W5TM4002	13/16" Blue T-Moulding, 55' per game
A5HU1200	Hub on Ball Loader Motor	A5TR2003	5/16" Chrome Trim, 2.87" on Marquee
A5LK2001	A05 Lock and keys	AACE8811	Speaker Assy.
A5LK5001	B44 Lock and keys	AABD1055	Chase Light Connector Board
A5LK5002	C15 Lock and keys	A5TD1	Ticket Dispenser
A5MO2200	Monitor, 22 Inch	AAMO3300	Motor, Ball Loader
A5ME3000	Metal Support Marquee	A5AC9093	Dollar Bill Acceptor, Down Stacker, 110AC
A5ME3001	Metal Motor Plate	AACB2203	Ball Trough Sensor
A5ME3005	Metal Rails, 6 per game	AACB2204	Interface/Communication Board
A5ME3010	Metal, Coin Door Stop	AACB3003	Ball Release Sensor
A5ME3017	Window Rails, 2 per game	A5CB3004	AUX Board for Lights in Cups
A5ME2035	Metal, Ticket Tray	AAMB8-HD	Motherboard
A5HO1003	Holder for LED Strips	AANEWGEN1-PJ/RBN	Minigen Board
A5FI9010	Line Filter , Power In		
	Head to Head Version Parts	AACM3000	Camera for Beer Pong
A5CORD14	Com cable to Link Board (2 player)	A5PS1008	Power Supply Ultra LS350W
AACE3325	Cable, Comm Linking, Game # 1		Head to Head Version Parts
AACE3326	Cable, Comm Linking, Game # 2	A5DE3058-2	Control Panel (Head to Head Version)
A5VF3050	Vacuum Form, Marquee	A5DE3061	Inside Marquee (Head to Head Version)
AACE3050	12 V Power Cable to Marquee LED's	A5DE3062	Outside Marquee (Head to Head Version)
AACE3051	Cable, Blue LED's in Marquee	A5DE3064	Left Bounce Guard (Head to Head Version)
AACE3052	Cable, White LED's in Marquee	A5DE3065	Right Bounce Guard(Head to Head V.)
		AACB0232	Converter Board (Head to Head Version)

# PARTS PICTURES

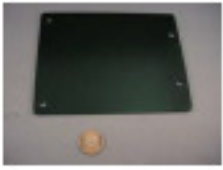

**A5PL9097**



**A5BA3001**



**A5CA1002**



**A5VF2002**



**A5CE1801**



**A5CN1031**



**A5CEAU010**



**A5CORD11**



**A5CORD23**



**A5CORD5**

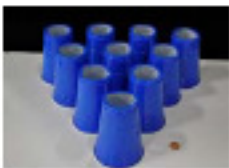

**AACU3001-10**



**A5FI9010**



**A5HU1200**



**A5OU1000**



**A5LI0001**



**A5LK2000**



**A5LK5001**



**A5PB3000**



**A5PB3001**



**A5PS1008**



**A5CN1031**



**A5CN3001**



**A5ME3001**



**A5ME3011**



**A5ME3012**

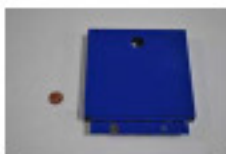

**A5ME3014**



**AACU3010**

# PARTS PICTURES

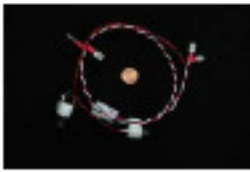

**AACBL4A-DOOR**



**A5LI0001**



**AACE8811**



**AAPB2700**



**AALIHL110**



**AAMO3300**



**AACE3300**



**AACE3301**



**AACE3302**



**AACE3303**



**AACE3304**



**AACE3306**



**AACE3307**



**AACE3309**



**AACE3310-X**



**AACE3311**



**AACE3316**



**AACE3318**



**AACE3319**



**AACE3320**



**AACE3327**



**AACE3328**



**AACE3329**



**AACE3330**



**AACE33331**



**AACB0232**

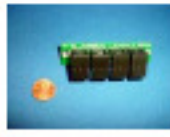

**AABD1055**



**A5CB3004**



**AACB2204**



**AACB2203**



**AACB3003**



**AAMB8-HD**



**AANEWGEN1-PJ/RBN**



**A5CM3000**

# PARTS PICTURES



A5DE3050



A5DE3050-1



A5DE3051



A5DE3052



A5DE3053



A5DE30054-1

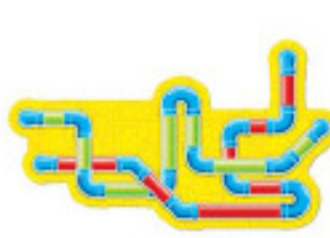

A5DE3054-2



A5DE3054-3



A5DE3055-1

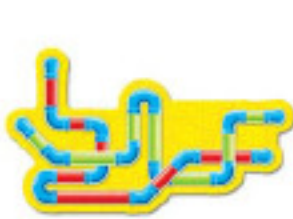

A5DE3055-2



A5DE3055-3



A5DE3057



A5DE3058-1



A5DE3058-2



A5DE3059



A5DE3060



A5DE3061



A5DE6062



A5DE3064



A5DE3065

# DECAL ID- SINGLE GAME



DECAL DIAGRAM



**PART #s NOT VISIBLE:**  
 ASDE3055-1\_SIDE FRONT LEFT  
 ASDE3055-2\_SIDE MIDDLE LEFT  
 ASDE3055-3\_SEAM DECAL LEFT  
 ASDE3060\_TICKET PATTERN SET

# DECAL ID- SHOOTOUT (DOUBLE)



DECAL DIAGRAM

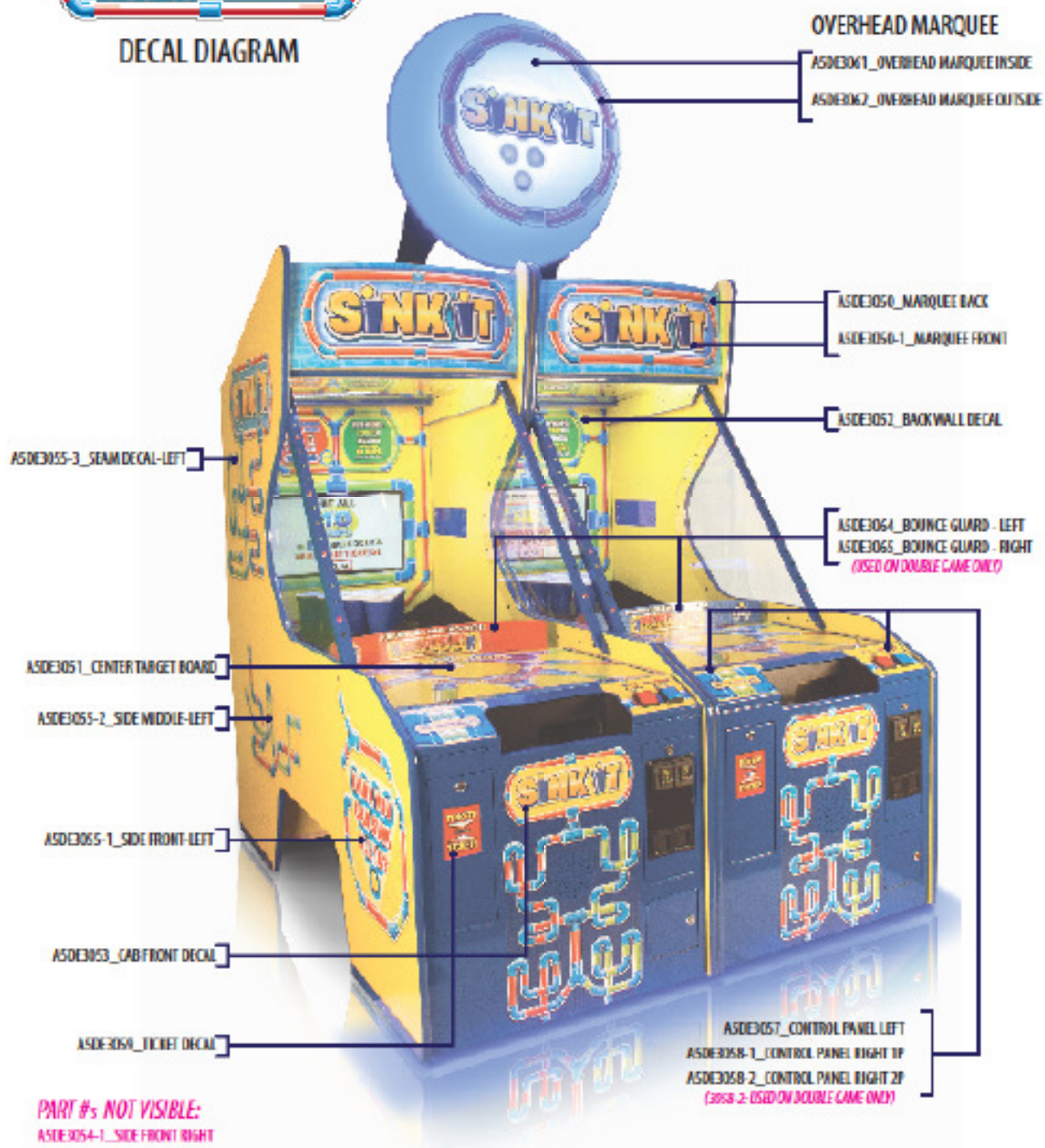

**PART #s NOT VISIBLE:**  
 ASDE3054-1\_SIDE FRONT RIGHT  
 ASDE3054-2\_SIDE MIDDLE RIGHT  
 ASDE3054-3\_SEAM DECAL RIGHT  
 ASDE3060\_TICKET PATTERN SET



# TECHNICAL SUPPORT

Excellent customer service is very important to Bay Tek Games!

We know that keeping your games in great operating condition is important to your business. When you need us, we are here to help. You can call us for free technical assistance, and you can count on us to have parts on-hand to support your game. We offer options that fit your needs.

## Electronics / Circuit Boards - Repair Options

**Repair & Return** – If you have Circuit Board issues with your Bay Tek game, you can send the board to us and we'll repair it right away. Most items sent to us are repaired and returned to you within two days. This option is your best value as we offer this fast turn-around service at the most reasonable price.

**Advance Replacement** – If you have Circuit Board issues with your Bay Tek game, but you don't have time to send in your board in for repair, give us a call and ask for an Advance Replacement. We'll send you a replacement board that same day (pending availability). When you get your new board, just repackage the defective board in the same box and send it back to us. We make it easy by including a UPS Return Shipping label for you to put on the box (not available for international shipments). This is your best option when you need to get your game up and running as quickly as possible!

**Spare Parts** – Take matters into your own hands and purchase new spare Circuit Boards for your Bay Tek games. Many of our games share the same main-board electronics. This means you can buy one set of spare electronics to support many of your Bay Tek games. Spare boards allow you to get your game up and running the quickest and provide you a valuable troubleshooting option. Call our technicians to get recommendations for what you should keep on hand for spare parts!

## Technical Support:

"You" are the best tool for troubleshooting! Your abilities to understand the game and your skills to repair the game are invaluable to us! If you need help, you know you can call us. It's not easy to diagnose a game remotely by phone, but our technicians do a great job. They'll need your help to perform some troubleshooting steps and convey to them exactly what's happening with your game.

## Returns, Credits, & Fees:

**NOTICE!** ALL ITEMS being sent to Bay Tek Games for repair or return, etc. require prior Return Authorization! Bay Tek Games will provide a Product Return Form with an authorizing Ticket Number for each item to be returned. Please be certain to include this document with all shipments!

**Late Fees and Non-Return Fees** - Advance Replacement and Warranty Replacement items require the defective items to be returned by Bay Tek games promptly to avoid Late Fees. We expect items to be returned with 10 working days. Late fees are invoiced monthly. Late fees are non-refundable under any circumstance! Any item not returned within 90 days will be invoiced in full as a replacement part.

**Bench Fees** - Bench fees will apply for each electronic item returned to Bay Tek Games (this includes unused Advance Replacement items). This charge covers our cost to inspect, evaluate and retest each item. Please note that returned items that do not pass our tests will be charged accordingly as replacement items or advance replacements.

**Restocking Fees** - Unused items returned for credit will be credited minus a restocking fee. Items must be returned within 30 days of purchase in order to qualify for any credit amount. No shipping charges will be credited.

# WARRANTY

Bay Tek Games warrants to the original purchaser that all component parts will be free of defects in workmanship and materials for a period of 6 months from the date of purchase. An additional 3 month warranty extension can be obtained by filling out and submitting the Warranty Registration for each machine. Warranty Registration cards may be found as shipped with each machine or online at our website. These must be filled out and submitted to Bay Tek Games within 30 days of purchase to be valid.

For any game/machine we manufacture that is within its warranty period, with notification to our Parts & Service Department, Bay Tek Games will, without charge, repair or replace defective component parts. It is the owner's responsibility to diagnose, remove and replace any faulty component part at their own expense & peril. As needed, at no charge, Bay Tek Games can provide reasonable telephone technical support during our normal business hours.

All claims of defective parts are subject to review upon our inspection of the faulty item. This warranty does not apply in the event of any misuse or abuse to the product, or as a result of any unauthorized repairs or alterations. The warranty does not apply if any serial number decal is altered, replaced or removed from its original position.

To process warranty replacement claims, customers may be charged for the replacement item at the time of shipment and later credited the same amount when the faulty item is returned and has passed our inspection. Bay Tek Games will provide the customer a pre-paid return shipping label which is sent along with the replacement item. The customer is responsible for properly packaging and shipping the faulty item back to Bay Tek Games.

	<b>ATTENTION</b>	
<p>In order to maintain the safety &amp; compliance certifications of this game, <b>ONLY</b> approved parts may be used. For approved replacement parts, refer to the parts list in this manual.</p>		

Should you need your game serviced, determine the serial number from the decal placed on the front of this manual, or locate it on the back of the game. Then contact our Service Department at: 920.822.3951 or e-mail: [service@baytekgames.com](mailto:service@baytekgames.com)

# NON-WARRANTY

Options and estimated charges will be provided to you for your approval.

Please remember that any items being sent to Bay Tek Games must include prior return authorization from our Parts & Service Department.

This approval will include a Product Return Form which is required to be included with any incoming shipments. Repaired parts will be shipped back using the same method in which they were received.

Repairs are warranted for 30 days from the date of return shipment.