

OPERATORS MANUAL

SHOOTING MANIA

V.M100US



PLEASE NOTE:

Read this manual **BEFORE** operating the machine.
Keep this manual for your reference.
Go to www.LAIgames.com click on Support to register your
games and receive future updates.



LAI Games

Correspondence regarding this machine should be addressed to your closest LAI Games office, or LAI Games Distributor.
For contact details, refer to the back page of this manual.

© LAI Games

Copyright Notice:

Authorization is hereby provided to you to copy this manual in its entirety provided such copies are used for non-commercial purposes and solely for use with LAI Games products. This authorization is specifically conditioned to include all legends, copyright, proprietary and other notices which appear herein are unaltered on any and all copies you make.

LAI Games

sales@laigames.com www.laigames.com

LAI Games Note

Dear Customer,

Keep up to date with new software updates or Service Bulletins for this game.

Check our website at www.laigames.com and click on Support, where you will find links to all the Bulletins and Software updates to keep your game in top working order.

Thanks,



Table of Contents

SAFETY PRECAUTIONS	5
MACHINE INSTALLATION AND INSPECTION	6
INTRODUCTION	7
DESCRIPTION	7
PACKAGING	7
CONTENTS	7
SPECIFICATIONS	7
DIMENSIONS	7
GAMEPLAY AND MODES	8
OBJECTIVE	8
HOW TO PLAY	8
ATTRACT MODE	9
PLAY MODES	9
OPERATION	9
OPERATOR MENU GUIDE	9
HARDWARE TEST	10
SYSTEM SETTINGS	10
BOOKKEEPING	11
ERRORS	11
SECTION A: SERVICE INSTRUCTIONS	12
LOCATING AND ACCESSING PARTS	12
REPLACING THE TICKET DISPENSER	16
REPLACING THE COIN ACCEPTOR	16
REPLACING THE LED TUBES	17
REPLACE A LIGHT TUBE	17
REPLACING THE LIGHT BOX	18
REPLACING THE MONITOR LED	18
REPLACING BUTTONS	19
REPLACING SPEAKERS	19
REPLACING THE MONITOR	20
REPLACING THE SCREEN CONTROL PANEL	20
MAINTENANCE	21
EXTERIOR	21
INTERIOR	21
WIRING DIAGRAMS	21

SAFETY PRECAUTIONS

The following safety precautions and advisories are used throughout this manual and are defined as follows.

* WARNING! *

Disregarding this text could result in **serious injury**.

* CAUTION! *

Disregarding this text could result in damage to the machine.

* NOTE! *

Is an advisory text to hint or help understand.



BE SURE TO READ THE FOLLOWING

* WARNING! *

Always turn **OFF** Mains AC power and unplug the game before opening or replacing any parts.

Always grasp the plug, not the line cord, when unplugging the game from an electrical outlet.

Always connect the Game Cabinet to a grounded electrical outlet with a securely connected ground line.

Always ensure the machine is at least 30cm from the wall and other machines.

Always ensure that at least two people move the machine to avoid accidents.

Do Not install the Game Cabinet outdoors or in areas of high humidity, sunlight exposure, direct water contact, dust, high heat or extreme cold.

Do Not install the Game Cabinet in areas that would present an obstacle in case of an emergency, i.e. near fire equipment or emergency exits.

Do Not obstruct the ventilation holes.

Do Not place any flammable objects close to the power cord.

* CAUTION! *

Always use a Digital Multimeter, logic tester or oscilloscope for testing integrated circuit (IC) logic PC boards. The use of a continuity tester is not permitted.

Do Not connect or disconnect any of the integrated circuit (IC) logic PC boards while the power is **ON**.

Do Not use any fuse that does not meet the specified rating.

Do Not Subject the game cabinet to extreme temperature variations. Reliability of electrical components deteriorates rapidly over 60 °C.

MACHINE INSTALLATION AND INSPECTION

When installing and inspecting *Shooting Mania*, be very careful of the following points and pay attention to ensure that the players can enjoy the game safely.

- Do not disassemble, change and modify the machine without authorization.
- Make sure to operate the machine as instructed by this manual. Inappropriate handling of the machine can cause damage to the machine.
- Make sure that the warning labels are clean and easy to read. If the labels are too dirty to be clearly read, please replace or clean them.
- Be sure to turn the power **OFF** before working on the machine.

*** WARNING! ***

Always Turn **OFF** mains power before removing safety covers and refit all safety covers when work is completed.

- Make sure the power cord is not exposed on the surface (floor, ground, etc.) where people walk.
- Check that the rubber glide feet levelers are set correctly on the floor so that the game cabinet is level and stable.
- Always make complete connections for the integrated circuit (IC) logic PC Boards and other connectors. Insufficient insertion can damage the electrical components.

*** CAUTION! ***

Before Switching the machine on be sure to check that it has been set on the correct voltage for your area!

Refer To the mains voltage adjustment section of this manual. Machines are normally shipped on 220V AC unless otherwise specified.

- Only qualified personnel should inspect or test the integrated circuit (IC) logic PC Boards.
- If any integrated circuit (IC) logic PC Boards should need servicing, please contact the nearest LAI Games Distributor. (Refer to the back page of this manual)

INTRODUCTION

Congratulations on your purchase of *Shooting Mania* by LAI Games. We hope you take the time to read this manual and learn about the many features and user-friendly adjustments that can be made to fine-tune the game for maximum earning potential.

DESCRIPTION

Shooting Mania is a carnival style, one to three player video game where each player has control over three static guns. The guns are all aimed at ropes with toys suspended from them, and move slowly from one side of the screen to the other. Each toy has an associated ticket value. When a player breaks a rope, they collect the dropped toy and its tickets. Players have a limited number of bullets to shoot and each rope will take a different number of bullets to break, so they must tactically decide which rope to shoot, and with which of their three guns.

PACKAGING

CONTENTS

- Shooting Mania Cabinet
- Operator Manual
- 2 x coin door key
- Allen key 3mm
- Allen key 4mm
- 3 x Sign board holder
- Sign board (PVC)
- Sign board

SPECIFICATIONS

DIMENSIONS

- Weight: 170kg (375lb)
- Height: 2189mm (86")
- Width: 1474mm (58")
- Length: 960mm (38")

LOCATION REQUIREMENTS

- Ambient temperature: 5C - 40C
- Ambient humidity: Low
- Ambient U.V. radiation: Very low
- Vibrations level: Low

GAMEPLAY AND MODES

OBJECTIVE

Use the three guns in your section to shoot bullets and break as many ropes as you can with the bullets you have. When you break a rope, you collect the toy and win the ticket value associated with that toy.

HOW TO PLAY

1. Insert credit to get bullets.
2. Press any of the three shoot buttons in your section to shoot a gun (sections are defined by color). The left button, will shoot the left gun, center button for center gun, right button for right gun.
3. Shoot the ropes of toys as they move across the screen. Some ropes are harder to break than others.
4. Break ropes to collect toys to win tickets.
5. The game is over when you run out of bullets.



GOLDEN BULLET

Breaking a rope and collecting a toy that has the golden bullet icon will grant the player extra bullets, as well as powering up the strength of their shots for a limited time.



COLLECTION BONUS

Each player section has a collection of toys to complete, visible at the top of their section of the screen. When a collection is completed, the player wins a bonus amount of tickets.



ATTRACT MODE

Shooting Mania always displays the gameplay screen, allowing players to insert a credit and play the game at any time.

PLAY MODES

COIN PLAY

Coin Play mode is entered by inserting a credit into one of three available player sections, then following the instructions in the “How to Play” section of this manual.

FREE PLAY

Free Play mode can be turned on by entering the operator menu, navigating to system settings, game settings, and turning the Free Play setting to *on*.

OPERATION

Press the Settings button on the service box to enter the operator menu. Please note that the operator menu cannot be accessed while a game is in progress or tickers are dispensing.

OPERATOR MENU GUIDE

- **MAIN MENU**
 - **HARDWARE TEST**
 - **I/O TEST**
 - **LAMP TEST**
 - **SOUND TEST**
 - **PAYOUT TEST**
 - **SCREEN TEST**
 - **SYSTEM SETTINGS**
 - **TOTAL DATA**
 - **GAME SETTING**
 - **TIME SETTING**
 - **PASSWORD SETTING**
 - **SYSTEM RESET**
 - **BOOKKEEPING**
 - **PERIODIC DATE**
 - **DAILY DATA**
 - **MONTHLY DATA**

HARDWARE TEST

I/O TEST

Use this menu to check the functionality of all the I/O on the cabinet, as well as the coin acceptor.

LAMP TEST

Use this menu to test if the cabinets lighting is functioning correctly.

SOUND TEST

Use this menu to test if the cabinet's speakers are functioning correctly.

PAYOUT TEST

Use this menu to test that the ticket dispenser is functioning correctly.

SCREEN TEST

Use this menu to ensure that the cabinets monitor is functioning correctly.

SYSTEM SETTINGS

To enter the System Settings menu, enter the system password – the default password is 00000000.

TOTAL DATA

This menu provides operational data.

GAME SETTINGS

The right hand side of the screen displays all the toys and their current associated ticket values.

- **Free Play** (Default: Off, Adjustable: On/Off)
Enable or disable free play mode.
- **Prize Display** (Default: Tickets, Adjustable: Tickets/Points)
Set if the game should use the terminology tickets or points.
- **Coin Rate** (Default: 1, Adjustable: 1-3)
Set the numbers of coins per credit.
- **Tickets Per Credit** (Default: 30, Adjustable: 10-100)
Set the average number of tickets to pay out per credit.
- **Bullets Per Credit** (Default: 10, Adjustable: 1-50)
Set the number of bullets the player is given per credit inserted.
- **Coupons** (Default: Off, Adjustable: On/Off)
Set the prize type to display as coupons.
- **Mercy Ticket** (Default: Off, Adjustable: Off,1-5)
Set the number of tickets that pays out when a player runs out of bullets.
- **Limited Time for Shooting** (Default: Off, Adjustable: Off, 20-30 seconds)
Limit the amount of time a player has to use their bullets.
- **Game Volume** (Default: 4, Adjustable: 0-8)
Adjust the volume of the game.
- **Demo Volume** (Default: 4, Adjustable: 0-8)
Adjust the volume of the game during demo mode.

TIME SETTING

This menu can be used to change the system time.

PASSWORD SETTING

This menu can be used to set the system password.

SYSTEM RESET

This menu can be used to restore the system back to default settings

BOOKKEEPING

PERIODIC DATA

This menu can be used to check the current and previous values for total coin in, total ticket out, mercy tickets, etc.







DAILY DATA

This menu can be used to check information about the current day's gameplays.

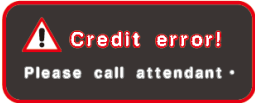
MONTHLY DATA

This menu can be used to check information about the current month's gameplays.

ERRORS

Error Icon	Cause
	An error occurred in the memory of the main Board. To fix this error, restart the cabinet.
	Check the functionality and wiring of the connection between the cabinet and the control panel.
	The system has reached the maximum amount of data it can store. Enter the operator menu, go to system settings and perform a system reset. You must reapply your game settings.
	Check the coin acceptor and ensure that no coins or other objects have become stuck. Once the coin acceptor has been cleared, press the Troubleshooting button to clear the error.
	Check the ticket dispenser and ensure that no tickets or other objects have become stuck. Once the ticket dispenser has been cleared, press the Troubleshooting button to clear the error.
	The game has run out of tickets. Reload the ticket dispensers, then press the Troubleshooting button to clear the error.

SECTION A: SERVICE INSTRUCTIONS

NOTE
Be sure to read the following carefully before servicing the machine.

LOCATING AND ACCESSING PARTS

The following pictures identify the location of the main serviceable items.

CABINET FRONT

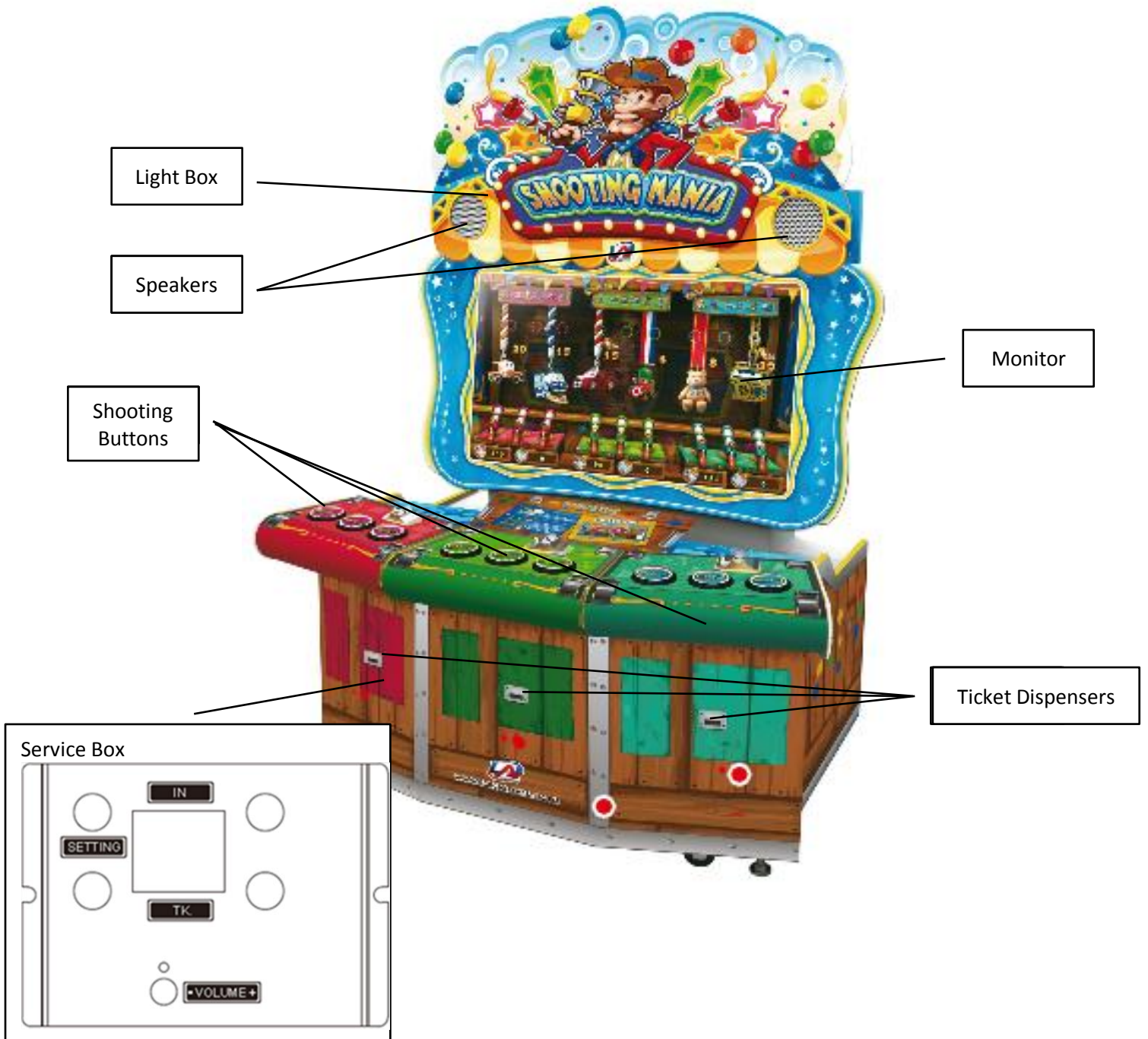

I/O BOARD

Power Supply : 12V 8.5A Providing power supply for IO board.
 12V 2.1A Providing power supply for AMP.

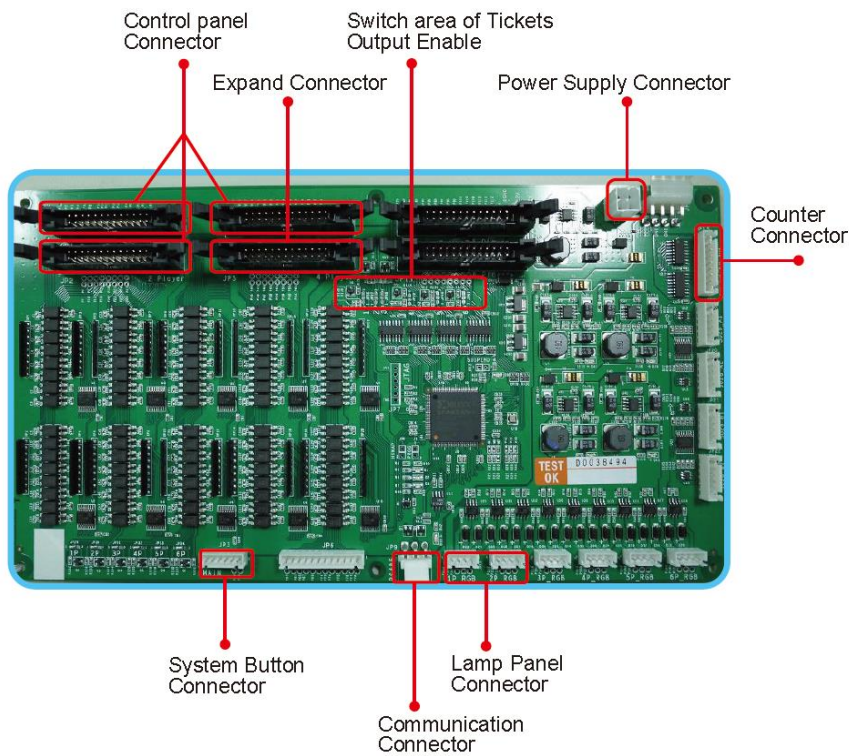

CONTROL PANEL CONNECTOR

The number order on the circuit board connector

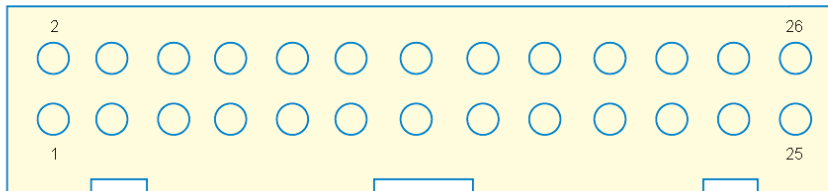

The location definition of circuit board connector (JP1, JP 2, JP 3)

2	4	6	8	10	12	14	16	18	20	22	24	26
		Shoot button 2		Controlling Hopper turn counter clockwise	Hopper feedback	Controlling Hopper turn clockwise	Lamp of the shoot button 1	+12V	+12V	GND	GND	GND
1	3	5	7	9	11	13	15	17	19	21	23	25
		Shoot button 1	Message for inserting coin	Troubleshooting button	Ticket feedback	Ticket control	Lamp of the shoot button 2	+12V	+12V	+5V	GND	GND

The location definition of the Expand Connector (JP5)

2	4	6	8	10	12	14	16	18	20	22	24	26
		2P Shoot button 3		3P Lamp of the shoot button 3	2P Shoot button 3		1P Lamp of the shoot button 3	+12V	+12V	GND	GND	GND
1	3	5	7	9	11	13	15	17	19	21	23	25
		1P Shoot button 3					2P Lamp of the shoot button 3	+12V	+12V	+5V	GND	GND

POWER SUPPLY CONNECTOR (JP35)

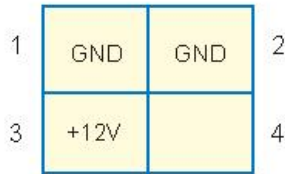

COUNTER CONNECTOR (JP15)

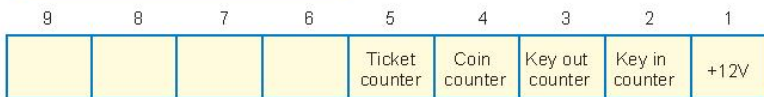

COMMUNICATION CONNECTOR (JP9)

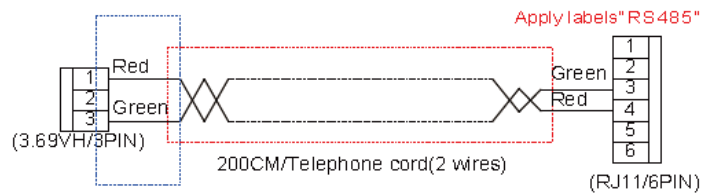
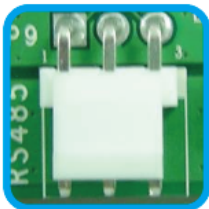

SYSTEM BUTTON CONNECTOR (JP3)

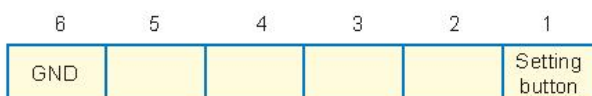

LIGHT STRIP LOCATIONS

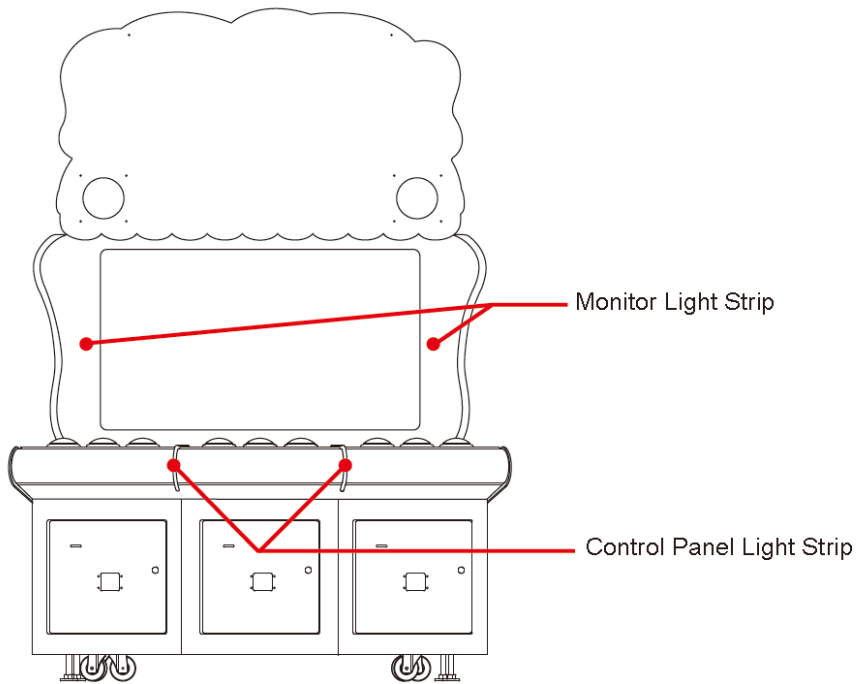

LAMP PANEL CONNECTOR (JP23, JP26)

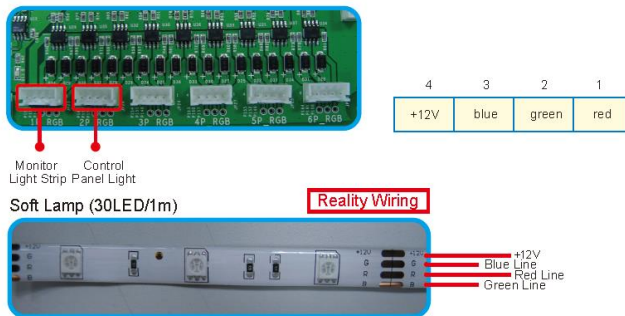

E2100 CONSOLE



REPLACING THE TICKET DISPENSER

1. Open the maintenance door.
2. Remove the four M4 screws and remove all connectors.
3. Remove the ticket dispenser.
4. Insert the new ticket dispenser and replace the four M4 screws.

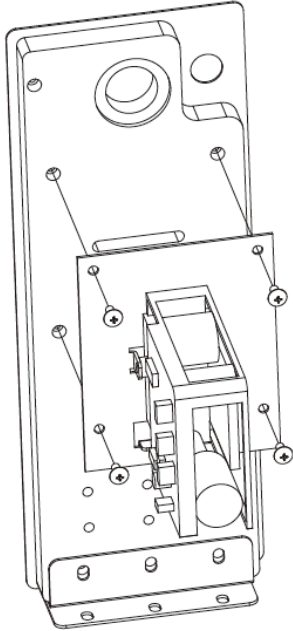

REPLACING THE COIN ACCEPTOR

1. Remove panel and all connectors.
2. Loosen the two M4 cross-headed screws.
3. Replace the coin acceptor and reassemble.

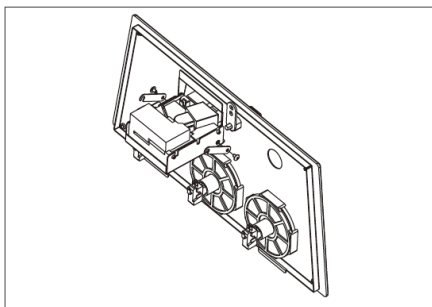
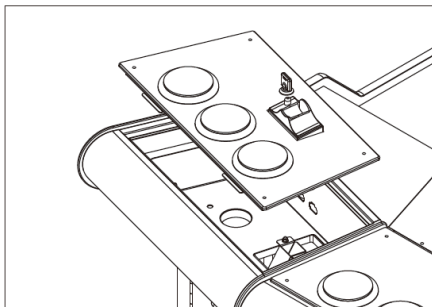

*** WARNING ***

Always turn **OFF** mains power and unplug the game, before replacing any lamps.
Always replace the lamps with the same or equivalent size, wattage and voltage.

REPLACING THE LED TUBES

1. Remove the panel and all connectors.
2. Loosen the two M4 screw nuts.
3. Replace the LED tube and reassemble.

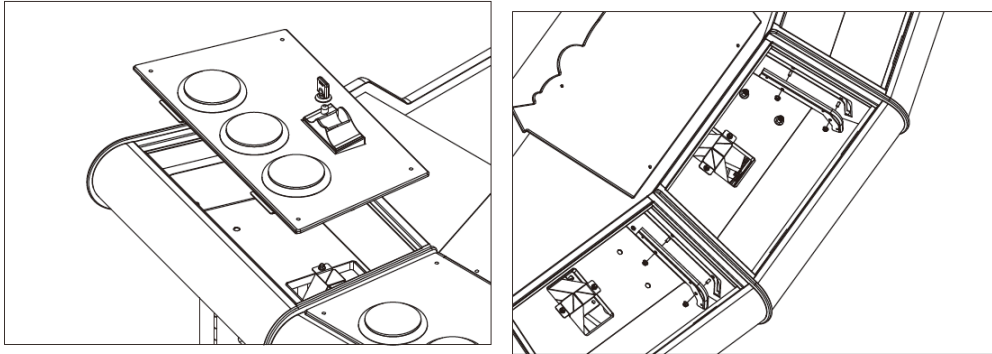

REPLACE A LIGHT TUBE

1. Remove all six M4 hexagon screws and remove the acrylic.
2. Replace light tube and reassemble.

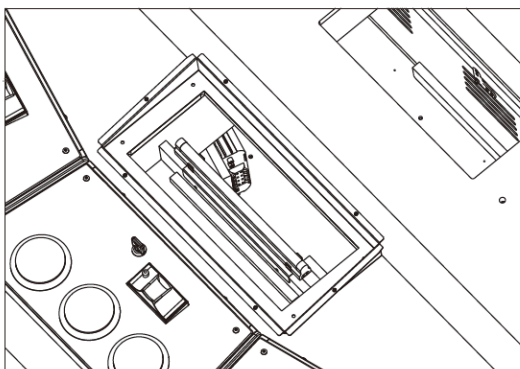
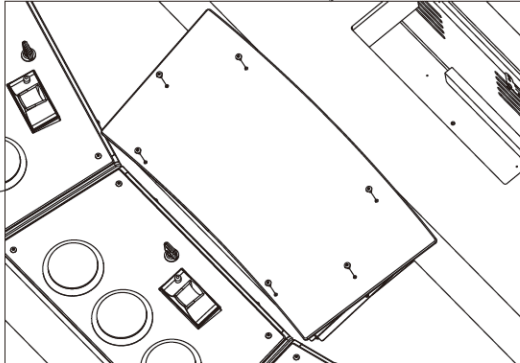

REPLACING THE LIGHT BOX

1. Remove the 10 M4 hexagon screws, then remove the PVC.
2. Remove the five M4 cross-headed screws and remove the acrylic cover.
3. Replace the light tube and reassemble.

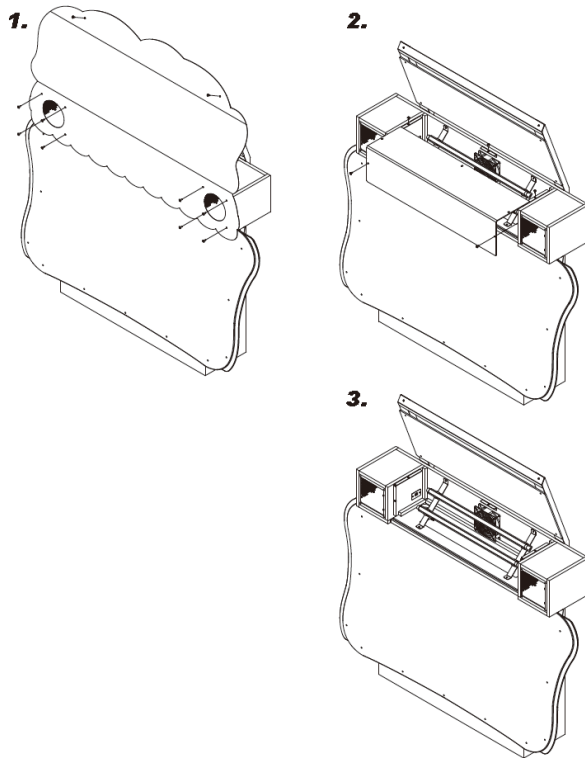

REPLACING THE MONITOR LED

1. Remove the three M4 hexagon screws and the three M4 screw nuts.
2. Replace the LED tube and reassemble.

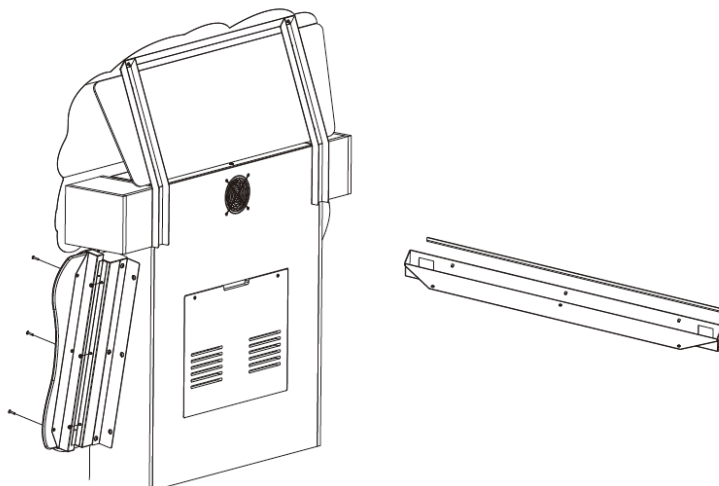

REPLACING BUTTONS

1. Remove panel and all connectors.
2. Remove the faulty button.
3. Replace with new button and reassemble.

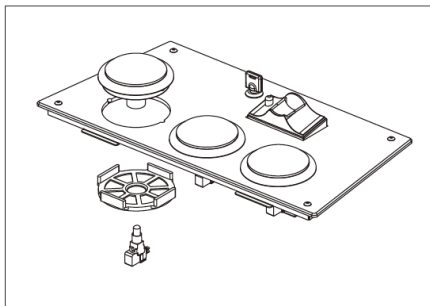
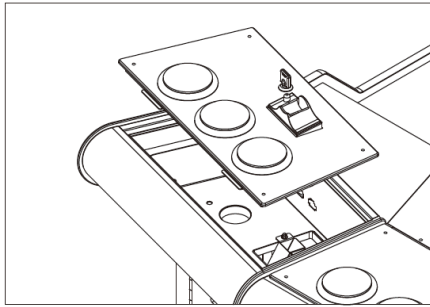

REPLACING SPEAKERS

1. Remove the 10 M4 hexagon screws and remove PVC.
2. Remove the four M4 cross-headed screws and remove the speaker cover and speaker set.
3. Remove the four M4 cross-headed screws, replace the speaker and reassemble.

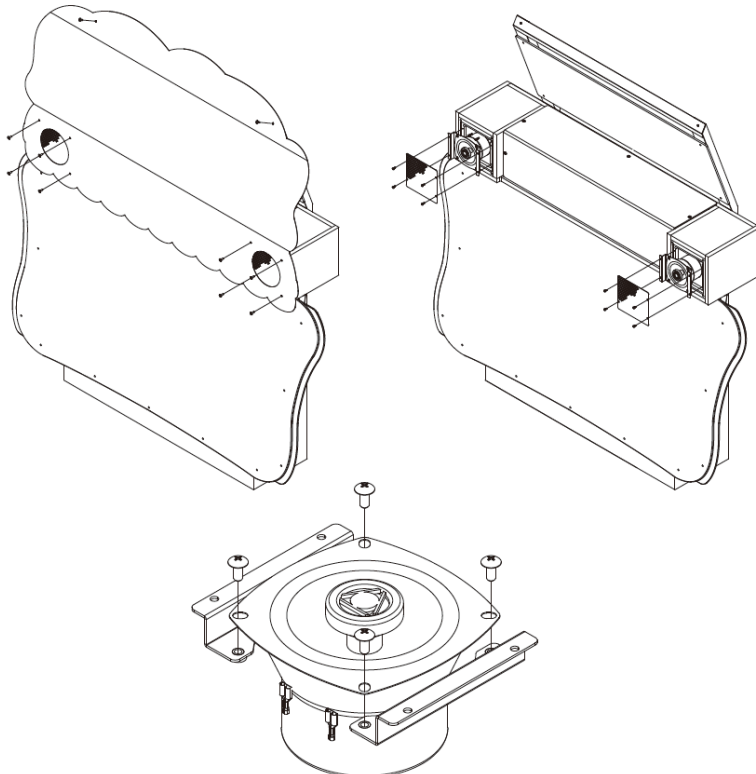

REPLACING THE MONITOR

1. Remove the two M4 screws, then remove the maintenance door and connector.
2. Remove the eight M3 cross-headed screws, then remove the monitor power board and control panel.
3. Remove the sixteen M4 hexagon screws, then remove the acrylic cover.
4. Remove the eight M4 cross-headed screws, replace the monitor, and reassemble.

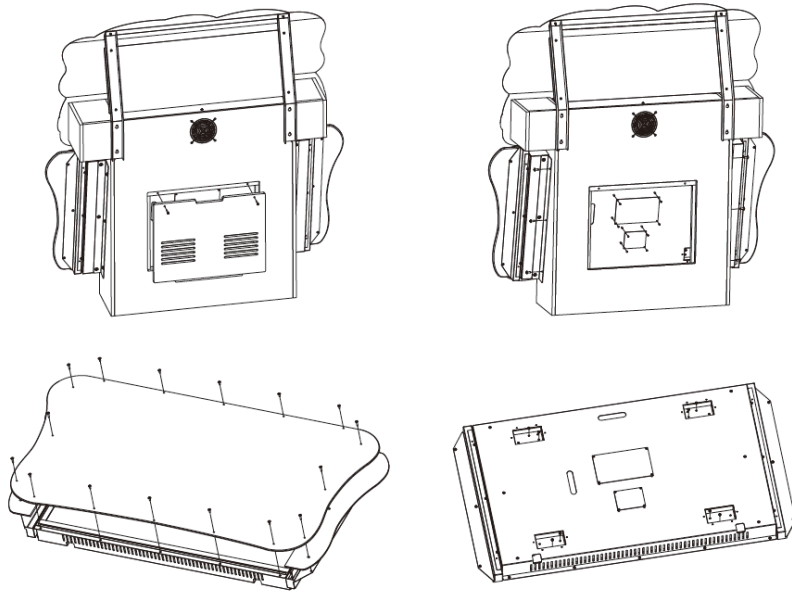

REPLACING THE SCREEN CONTROL PANEL

1. Remove the two M4 screws, then remove the maintenance door.
2. Replace the monitor control panel and reassemble.

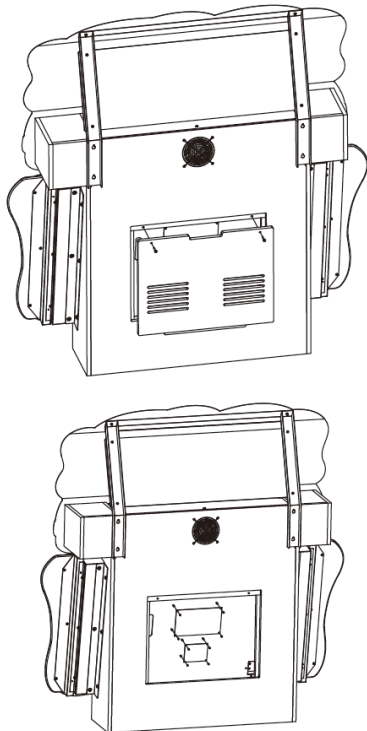

MAINTENANCE

EXTERIOR

- Regularly dust and clean the external cabinet areas as required, using a soft water-damp cloth and mild soap.
- Check for blown bulbs and replace as required. Check all LED strips are functioning and repair as required.
- Check the monitor image is clear.
- Wipe the monitor clean with a soft damp cloth.

INTERIOR

- Regularly dust and vacuum the interior of the cabinet, taking care to remove any objects that may have fallen.
- Check and tighten all fixing hardware and fasteners as required.

*** WARNING! ***

Always turn OFF mains power and unplug the game before cleaning the interior of the machine.

WIRING DIAGRAMS

(next page)

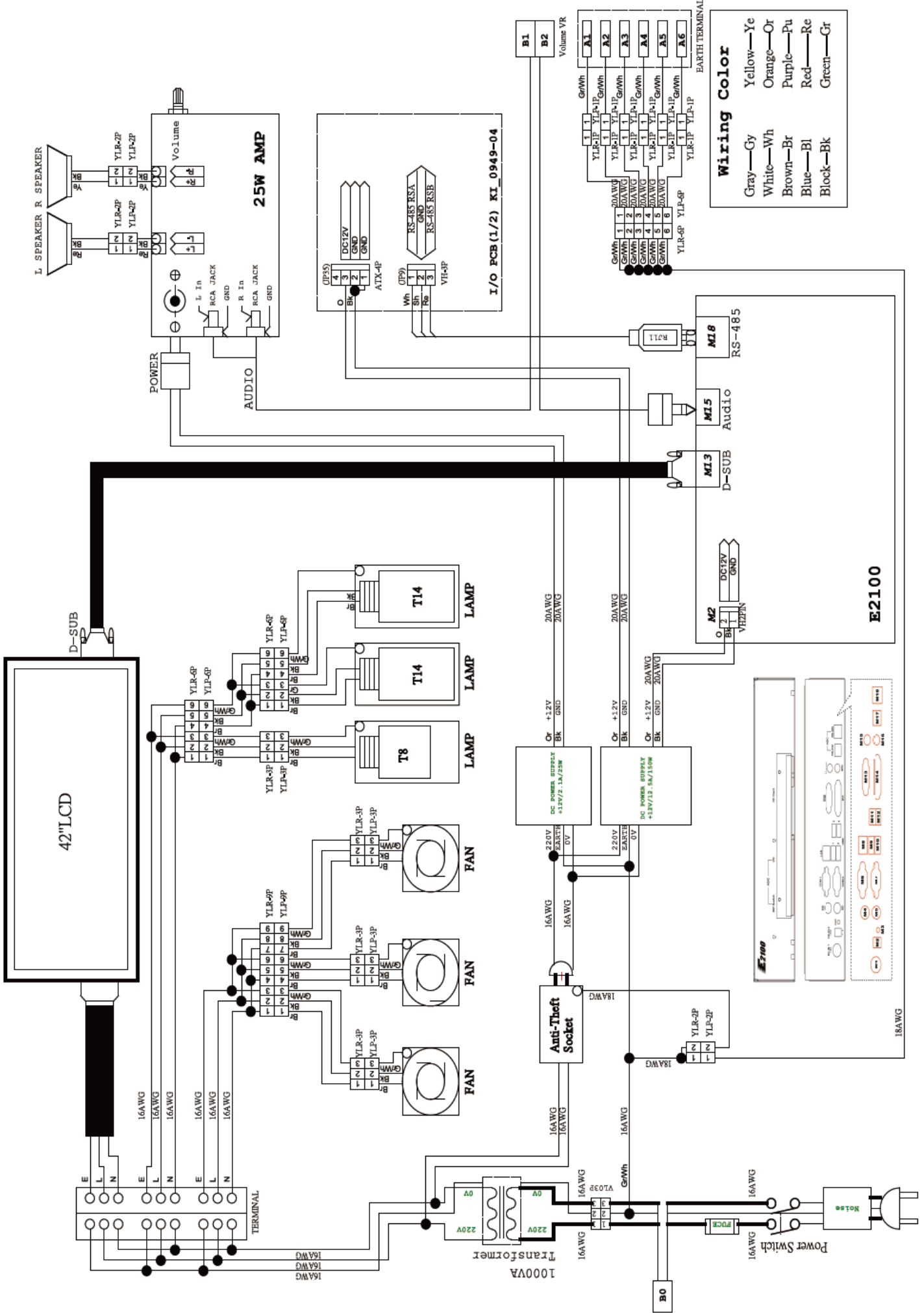

Wiring Color

Gray	→	Gy
White	→	Wh
Brown	→	Br
Blue	→	Bl
Black	→	Bk
Yellow	→	Ye
Orange	→	Or
Purple	→	Pu
Red	→	Re
Green	→	Gr

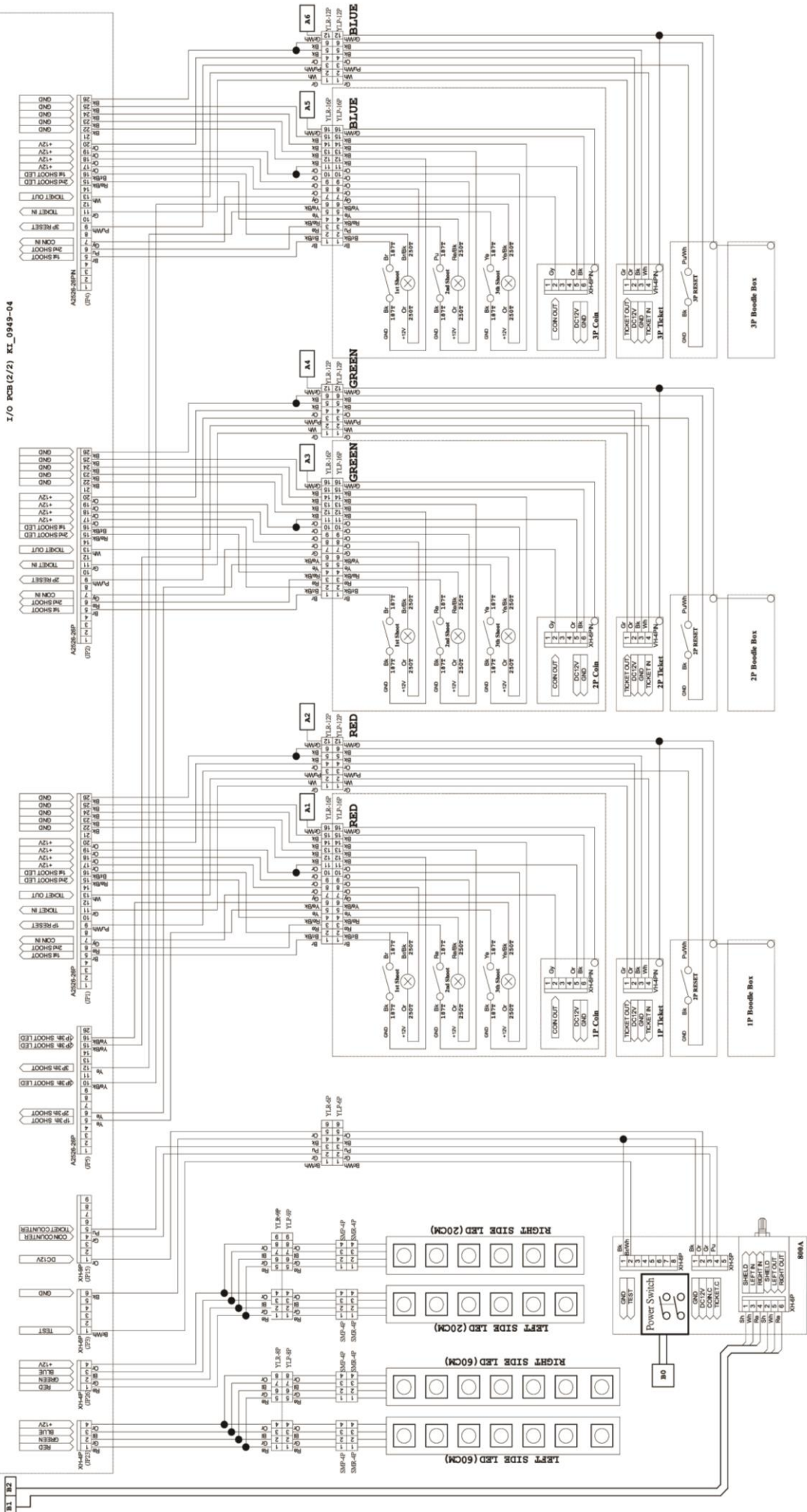

Disclaimer

OPERATOR WILL TAKE NOTE

By accepting delivery of and placing this hardware and licensed software into operation, the Operator represents and warrants that it will only operate the hardware and licensed software provided by LAI Games in compliance with the regulatory requirements of the country, state, and/or municipality in which the hardware and licensed software are used and/or operated. LAI Games has provided this hardware and licensed the software **only** for legitimate and legal use, and any use of the hardware and licensed software in a manner that violates any laws of the country, state, and/or municipality in which the hardware and licensed software are used and/or operated is wholly unauthorized and shall be at Operator's sole and complete risk.

Operator assumes any and all risk and liability for any civil or criminal legal claims or causes of action arising from the unauthorized use and/or operation of the provided hardware and licensed software, such improper and unauthorized use specifically including, but not limited to:

- (a) Operating or allowing the operation of the hardware and licensed software in a manner that violates the laws and regulations of the country, state, and/or municipality in which the hardware and licensed software are used or operated;
- (b) Assembling or causing the assembly of the hardware in a manner not authorized by or disclosed in this manual;
- (c) Any tampering with, changes to, or modifications of the licensed software that occur after the software leaves LAI Games' factory that is not made by authorized LAI Games personnel and that is directly or indirectly caused by Operator; and
- (d) Any tampering with the computer chip/electronic programmable read only memory (EPROM) by or on behalf of Operator that directly or indirectly causes the tamper-indicating holographic seal on the computer chip/EPROM to be broken or damaged in any way.

LAI Games shall have no liability related to such improper and unauthorized use and/or operation of the hardware and licensed software, and Operator shall indemnify, defend, and hold LAI Games harmless for any claim or cause of action brought against LAI Games arising from Operator's or Operator's representative's improper and unauthorized use and/or operation of the hardware and licensed software.

Any improper and unauthorized use shall completely and totally void any and all warranties, both express and implied, of the hardware and licensed software provided by LAI Games.

WARRANTY

LAI Games warrants its manufactured products for a period of 3 months inclusive of parts and labor from the date of sale.

LAI Games exclusive obligation is to repair any item with any defects as a result of faulty workmanship or materials, providing the defective item or items of equipment are returned to the LAI Games distributor from which the machine was purchased.

LAI Games shall have no obligation to make repairs necessitated by negligence or interference to any component by any unauthorized personal. This will automatically void any existing warranty.

IF MAKING A WARRANTY CLAIM:

- (a) A Copy of the sales invoice must accompany the claim.
- (b) To and from Transport and freight costs are not covered by the warranty.
- (c) Warranty is not transferable with the sale of a machine from one owner to another.





INTERNATIONAL SALES & SERVICE

Sales/Enquiries: sales@laigames.com
Tech. Support: support@mleisure.co.id
Website: www.laigames.com

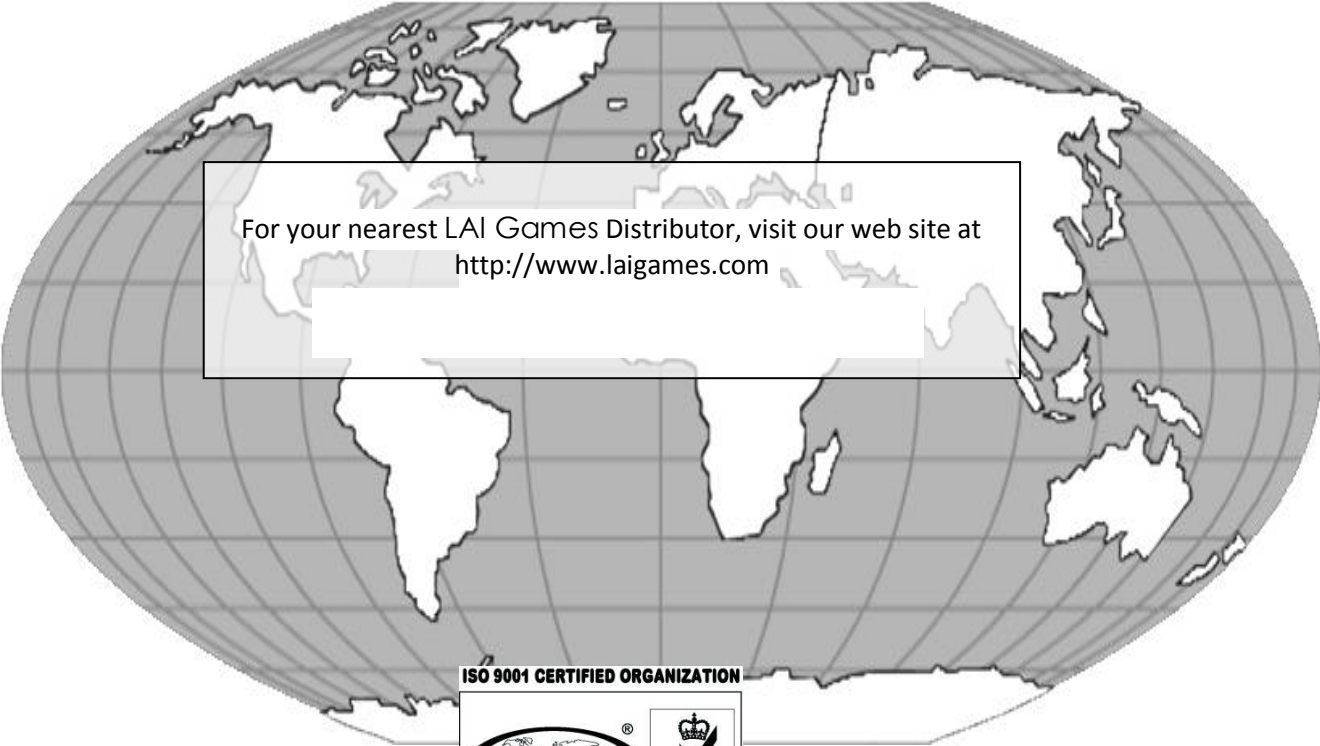
A stylized world map in white outlines is centered on a grey grid background representing a globe.

For your nearest LAI Games Distributor, visit our web site at
<http://www.laigames.com>

ISO 9001 CERTIFIED ORGANIZATION



ISO 9001: 2008 Cert No. 17460