



Table of Content

Safety	4
Setup	5
Control Panel	
- Access	6
- Game Mode display	
- Switches during attract mode	
- Programming Mode and Options	7
Payout Zones	9
Audits and Error Codes	10
Test Modes	11
Playfield Drive Assembly	12
Score Switches	13
Service Access	14
Power Supply Specifications	15
General Illumination	16
Goalie Motor Replacement / Sensor	17
PCB Part locations and part number	18
Spare Part list	19
Warranty	20

SAFETY AND WARNINGS BEFORE YOU BEGIN

WARNING: WHEN INSTALLING THIS GAME, A GROUNDED A.C. RECEPTACLE MUST BE USED. FAILURE TO DO SO COULD RESULT IN INJURY TO YOURSELF OR OTHERS. FAILURE TO USE A GROUNDED RECEPTACLE COULD ALSO CAUSE IMPROPER GAME OPERATION, OR DAMAGE TO THE ELECTRONICS.

NOTE: THIS GAME IS INTENDED FOR INDOOR USE ONLY.

DO NOT DEFEAT OR REMOVE THE GROUNDING PRONG ON THE POWER CORD FOR THE SAME REASON AS GIVEN ABOVE. USING AN IMPROPERLY GROUNDED GAME COULD VOID YOUR WARRANTY.

HAVE A QUALIFIED ELECTRICIAN CHECK YOUR A.C. RECEPTACLE TO BE SURE THE GROUND IS FUNCTIONING PROPERLY.

THIS GAME IS DESIGNED TO DISSIPATE STATIC ELECTRICITY THROUGH THE GROUNDING PLANE OF THE GAME. IF THE A.C. GROUND DOES NOT WORK, THE GAME COULD DISCHARGE STATIC ELECTRICITY THROUGH THE GAME CIRCUITRY, WHICH COULD CAUSE DAMAGE.

THE POWER SUPPLY IS NOT VOLTAGE ADJUSTABLE. TO OPERATE THE GAME AT VOLTAGES OTHER THAN THOSE IT WAS DESIGNED FOR. PLEASE CONTACT OUR SERVICE DEPARTMENT FOR VOLTAGE CONVERSION INFORMATION.

WARNING

DO NOT remove any of the components on the main board (e.g. compact flash and eproms) while the game is powered on. This may cause permanent damage to the parts and the main board. Removing any main board component part while powered on will void the warranty.

ALWAYS REMOVE POWER TO THE GAME, BEFORE ATTEMPTING ANY SERVICE, UNLESS NEEDED FOR SPECIFIC TESTING. FAILURE TO OBSERVE THIS PRECAUTION COULD RESULT IN SERIOUS INJURY TO YOURSELF OR OTHERS.

THIS GAME IS NOT SUITABLE FOR INSTALLATION IN AN AREA WHERE A WATER JET COULD BE USED.

This appliance is not intended for use by persons (including children) with reduced physical, sensory or mental capabilities, or lack of experience and knowledge, unless they have been given supervision or instruction concerning use of the appliance by a person responsible for their safety. Children should be supervised to ensure that they do not play with the appliance

AC Power Information

The games main fuse is accessed through the back of the game at the power mod. Above the power cord is a small panel that contains the main fuse. The value of the fuse for 120 volt users

SETUP

Lift the back panel up and secure with two bolts and washers located in the parts package in your cashbox. Open the upper back door and install two bolts and washers inside at the bottom. The diagram shows the backing removed for clarity.

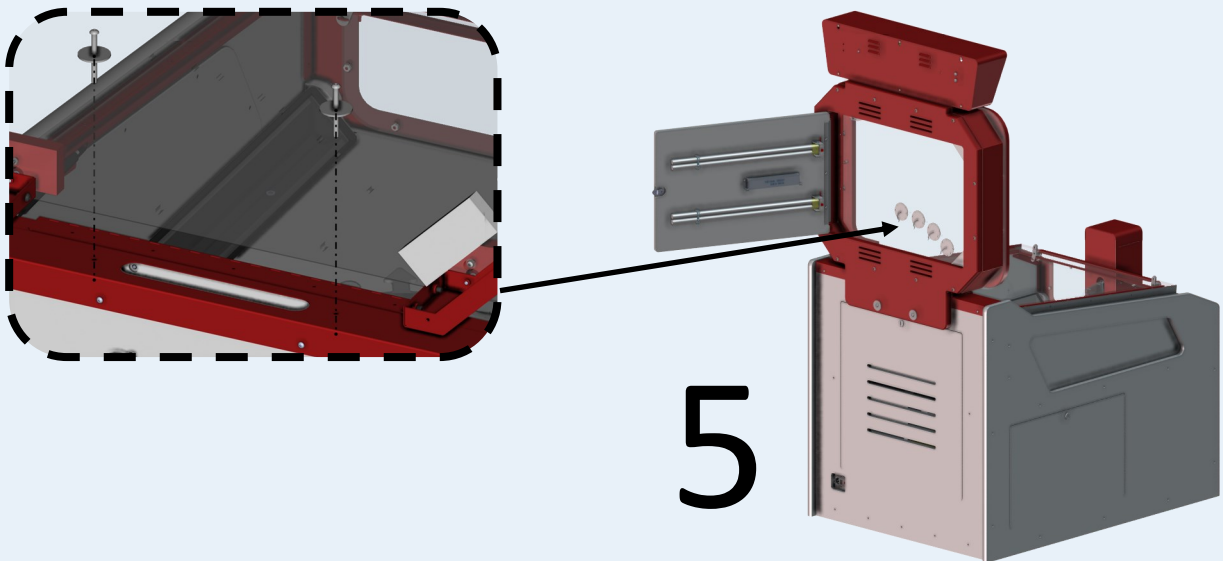
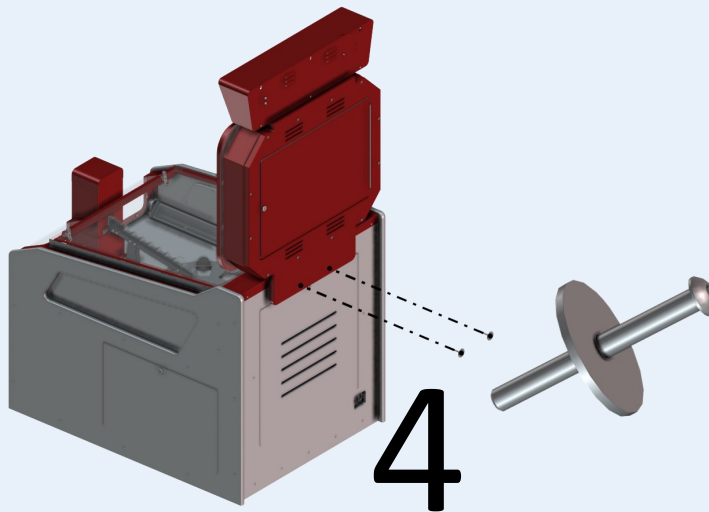
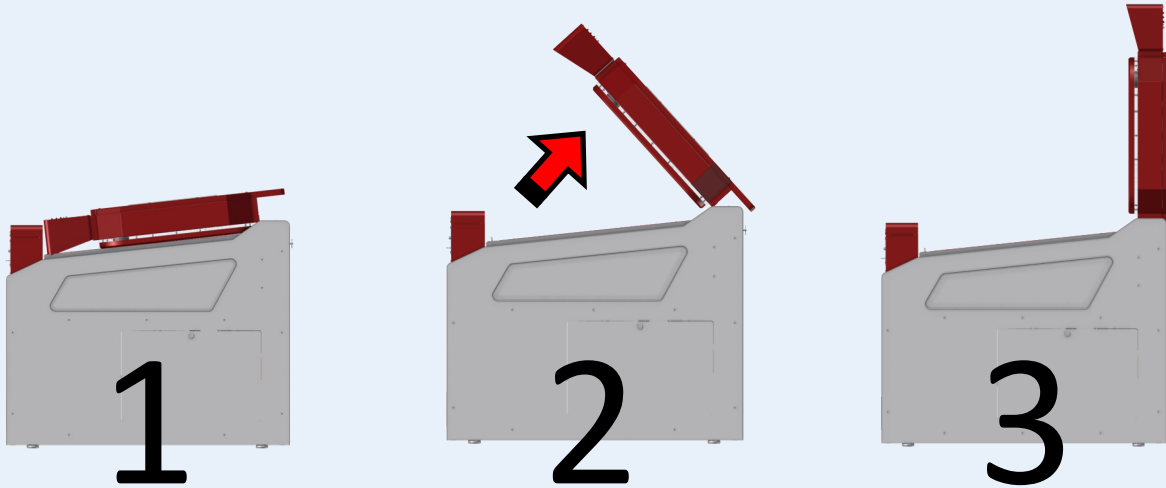

Control Panel Access

The control panel is located through the front access door. It has a display, control switches, main AC power switch, volume control, and meters.

The Main AC power switch must be in 1 position to power on. To increase the volume, turn the volume knob clockwise. To decrease the volume, turn the knob counter-clockwise.

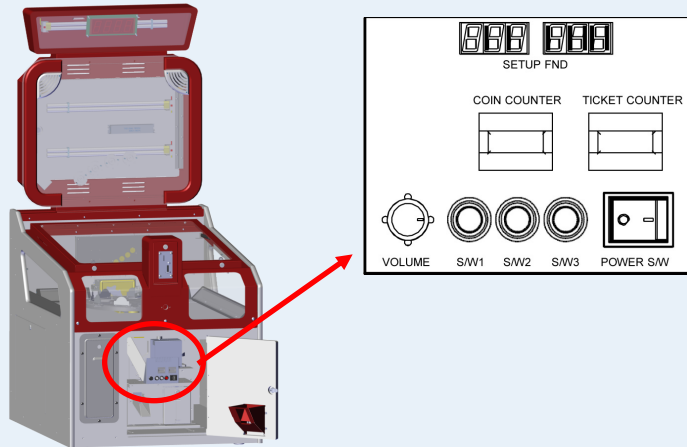

Control Panel - Game Mode - Display

The control panel which is located through the front access door will display what tickets are owed if tickets run out. You will need to press the ticket reset button located below the ticket dispenser to finish dispensing tickets.

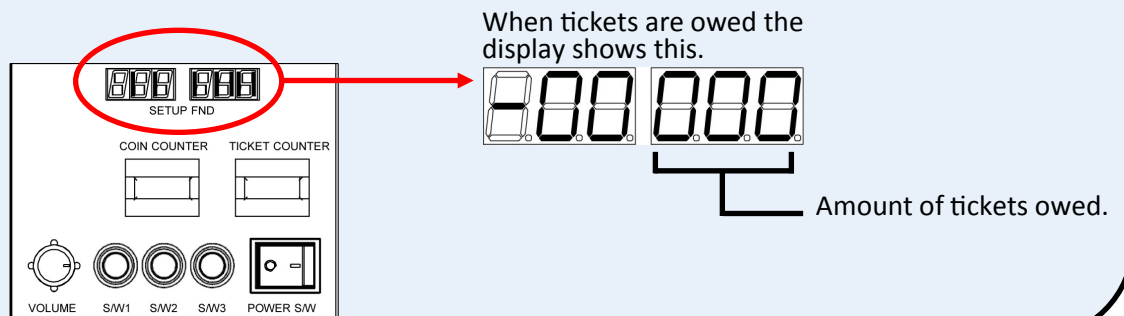

Control Panel - Switches During Attract Mode

Pressing the switch labeled "SW1" will enter setup and audit mode.

Holding the switch labeled "SW2" during power up will cause the game to do a factory reset.

Pressing the switch labeled "SW3" will give a credit as though a coin had been dropped in play.

Holding the switch labeled "SW3" during power up will enter test mode.

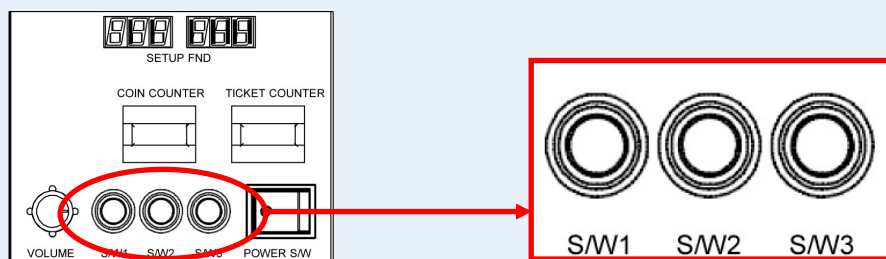

Control Panel - Programming Mode

When you press SW1 during the attract mode the game will leave game mode and enter programming and audit mode. The game will stop the rotation of the playfield and display "rEAR" on the control panel. The upper display will show "Cset" to indicate it is in programming and audit mode.

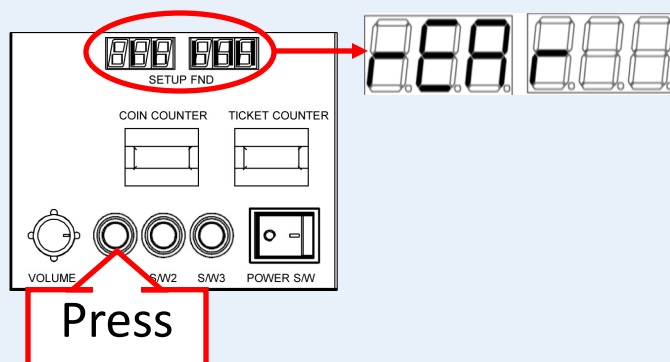

If you press the switch labeled "sw2" you will enter into programming mode. Here you can change the various options of the game.

If you press the switch labeled "sw3" you will enter audit mode. Here you can review various statistics of your game.

Adjusting Program Options

The control panel display will show the option number on the left display while showing the value of that option on the right display. The button labeled "SW2" will advance through the various options. Use the button "SW3" to increment the value stored for that option displayed. Once you have cycled through all the options the game will display "rEAR" again. Press the button "SW1" to save your settings.

- | | | |
|--|--|--|
| | | Option 1: "Jackpot start value" Starting point for how many tickets a player can win if they hit the jackpot. |
| | | Option 2: "Jackpot limit" This limits the amount the jackpot can reach. The maximum value is 999. |
| | | Option 3: "Mercy Ticket" The game will dispense up to 9 tickets in addition to whatever the coin scores. A value of 0 will disable this option. |
| | | Option 4: "Jackpot Increment" The jackpot will advance by this value for every coin in until the jackpot is won. It will reset to "jackpot start value" when won. |
| | | Option 5: "Disabled" This option should be left on 1. |
| | | Option 6: "Defense Tickets" See "Payout Zone" chart for location of Zone A on playfield. If the coin lands in zone A it will pay out this value in tickets. |
| | | Option 7: "Playfield Speed" This value sets the rotation speed of playfield. |
| | | Option 8: "Goalie Speed" During normal play this value determines how fast the goalie will travel back and fourth. |

** Continued on next page **

Adjusting Program Options (continued)

 **Option 9:** "Penalty Goalie speed" When the player spells "GOAL" and attempts a penalty kick for the jackpot the goalie will change to this speed.

 **Option 10:** "Penalty Kick Fail" Game will pay out this value in tickets instead of the jackpot when a player misses the goal during the penalty kick attempt.

 **Option 11:** "G value" The game will dispense this value in tickets when the player scores a goal and lights the letter G. See "Payout Zone" chart for location of Zone C on playfield.

 **Option 12:** "O value" The game will dispense this value in tickets when the player scores a goal and lights the letter O. See "Payout Zone" chart for location of Zone C on playfield.

 **Option 13:** "A value" The game will dispense this value in tickets when the player scores a goal and lights the letter A. See "Payout Zone" chart for location of Zone C on playfield.

 **Option 14:** "L value" The game will dispense this value in tickets when the player scores a goal and lights the letter L. See "Payout Zone" chart for location of Zone C on playfield.

 **Option 15:** "Goalie block Score" See "Payout Zone" chart for location of Zone B on playfield. If the coin lands in zone B it will pay out this value in tickets.

 **Option 16:** "DEMO SOUND" Setting this to 0 will disable attract audio. Setting this to 1 will enable it.

 **Option 17:** "Penalty Kick arrow alignment" This option is to adjust where the arrow lines up when in Penalty Kick mode.

 **Option 18:** "Hopper Payout" Game will payout these many coins when the swipe line is grounded.

 **Option 19:** "Save" Save setup and return to game mode.

PAYOUT ZONES

Zone A value is set in option b-6. Defense players' graphics are included.





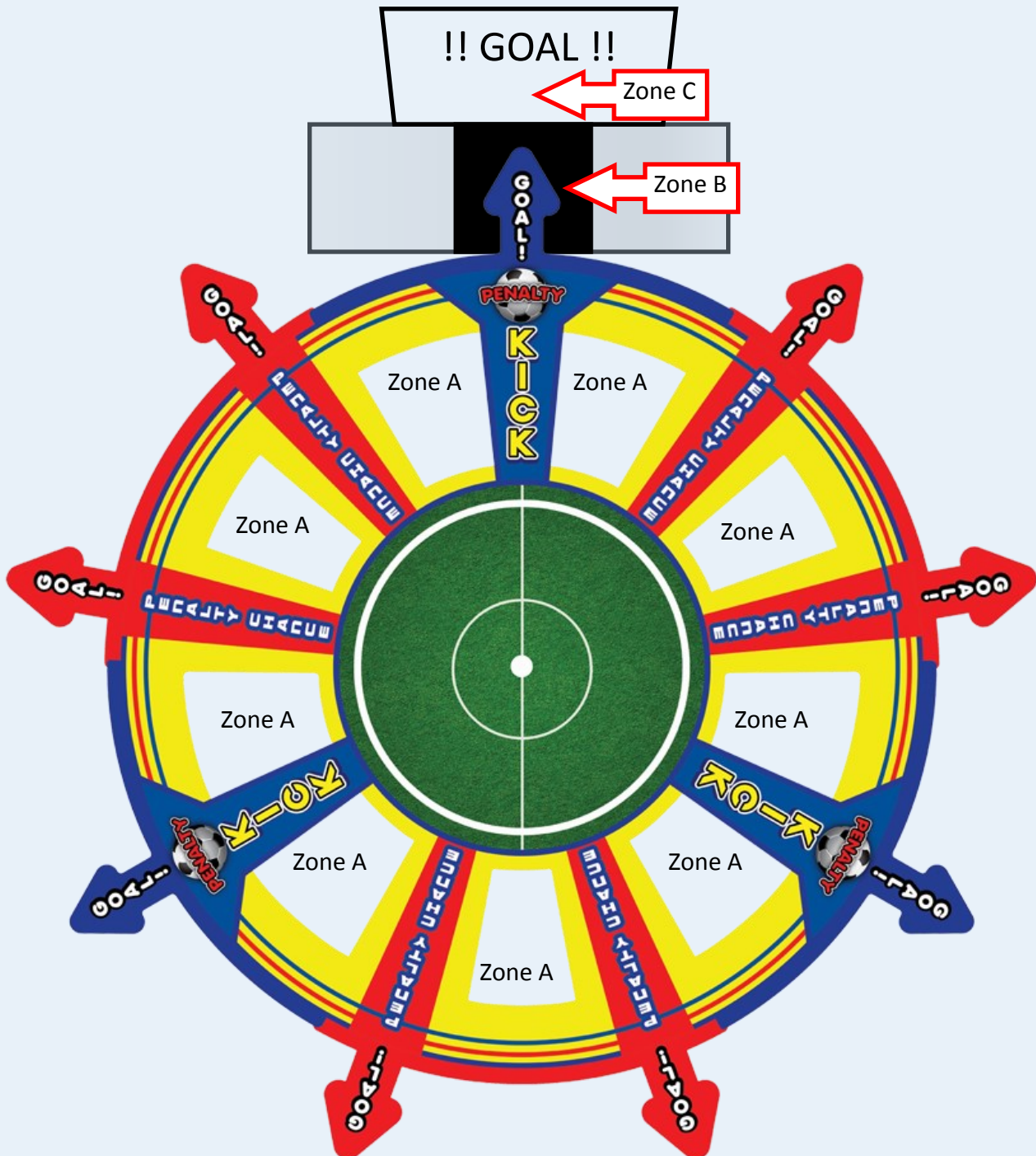

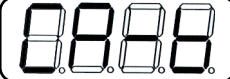

Zone B value is set in option b-A.

Zone C values are set in options F-1, F-2, F-3, and F-4. Each time a player scores a goal, the game will light which letter it is on and give that many tickets away for that letter.

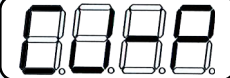

Audits

To enter the Audit mode, you must first press the button labeled "SW1" from game mode. The display will show "rEAR" as described in section "Control Panel - Programming Mode". Now press the button labeled "SW3" to enter Audit mode. Using the button labeled "SW2" you can cycle through the different audits and view their values. To clear the current audit's value press the button labeled "SW3". Press the button "SW1" at the "Exit Audit Mode" to exit audit screen and return to "Setup Mode".

	Accumulated Tickets		Total count of no goal
	Accumulated Jackpot Tickets		Total count in defense area
	Total Dispensed Tickets		Exit audit mode
	Total Coin Income		
	Total Jackpot Count		
	Total count of goal in goalie		

Error Codes

If the game encounters a critical error it will not be in game mode but display one of these errors. Once the error is corrected it might be necessary to power cycle the game.

 Playfield Motor Error :

 Goal Keeper Motor Error:

 Ticket Error:

 Hopper Error:





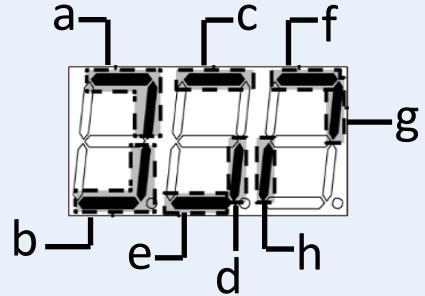
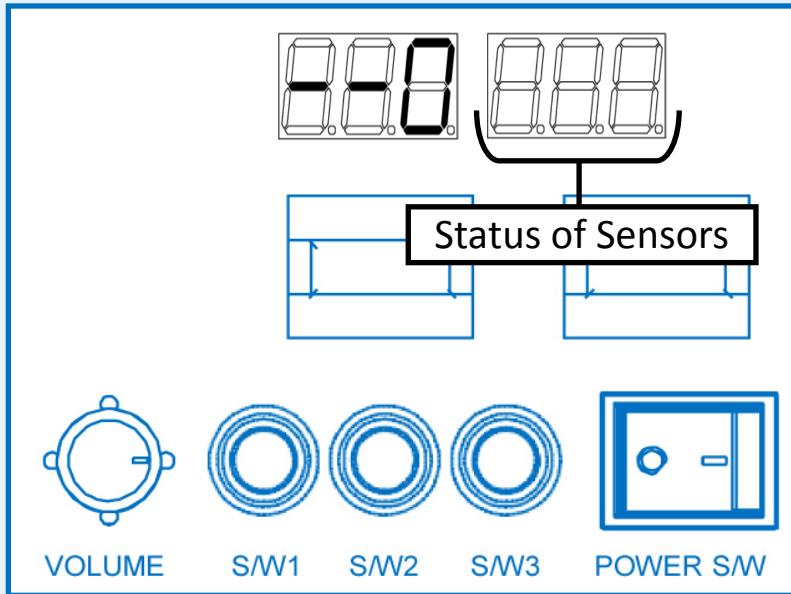



Test Mode

To test the various functions of the game you will need to enter the Test mode. To enter this mode, the game must be off. Press and hold the button labeled "SW3". Now switch the power of the game to on. The Jackpot display will show "C--0". The Control panel display will show the status of the sensors. See below for explanation.



- a. Goal Sensor
- b. No Goal Sensor
- c. Coin Sensor
- d. Ticket Sensor
- e. Ticket Empty Lamp
- f. Playfield Home Sensor
- g. Playfield Motor Position sensor
- h. Goal keep Motor sensor

Push the button labeled "SW1" to select the test you wish to perform. The bonus display will show C followed by the test number shown below. At anytime you can press the button labeled "SW2" to play a game sound.

-  Pressing the button labeled "SW3" when this is displayed in the control panel display will exit back to game mode. The bonus display will show "C0-0".
-  Pressing the switch labeled "SW3" will turn on all the displays when this is shown in the control panel display. The bonus display will show "C1-0"
-  Pressing the switch labeled "SW3" will turn on the ticket dispenser motor when this is shown in the control panel display. The bonus display will show "C2-0"
-  Pressing the switch labeled "SW3" will turn on the ticket empty lamp when this is shown in the control panel display. The bonus display will show "C3-0"
-  Pressing the switch labeled "SW3" will advance the coin meter when this is shown in the control panel display. The bonus display will show "C4-0"
-  Pressing the switch labeled "SW3" will advance the ticket meter when this is shown in the control panel display. The bonus display will show "C5-0"
-  Pressing the switch labeled "SW3" will turn on the goalie motor when this is shown in the control panel display. The bonus display will show "C6-0"
-  Pressing the switch labeled "SW3" will turn on the playfield motor when this is shown in the control panel display. The bonus display will show "C7-0"

Playfield Drive Assembly

Remove the playfield deck by removing the four mounting screws shown. You do not have to remove the coin chute in order to remove the upper playfield deck.

The playfield sensor tells the main board where the wheel is at all times. As the motor turns the playfield, the large encoder wheel spins pulsing the bottom section of the sensor. When the player spells "SCORE" the game uses the top part of the sensor to position the wheel correctly for the player to take their penalty shot. When servicing this assembly, you might be necessary to adjust the software alignment position. See option 17 in programming to set this value.

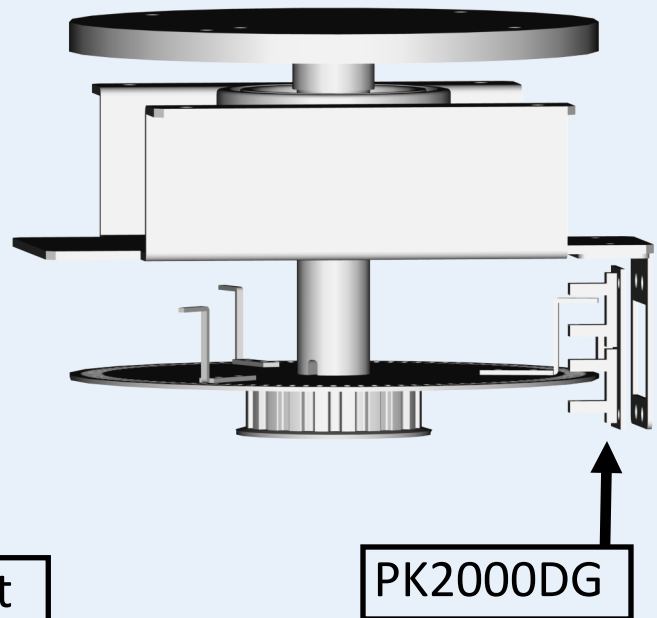
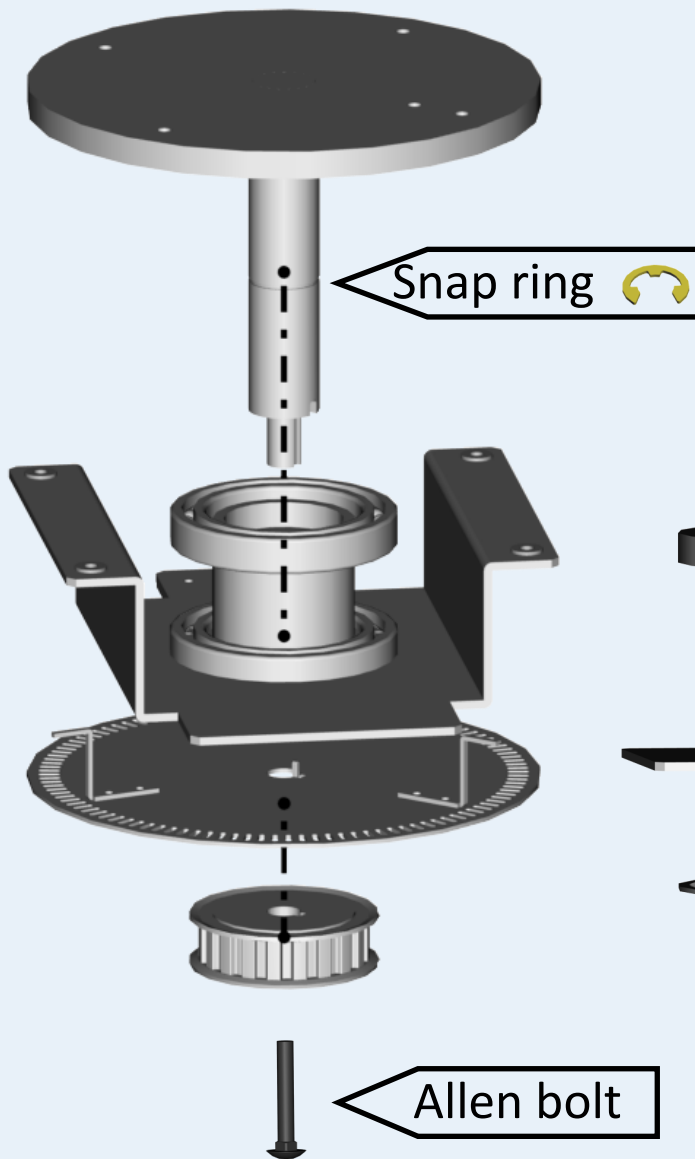
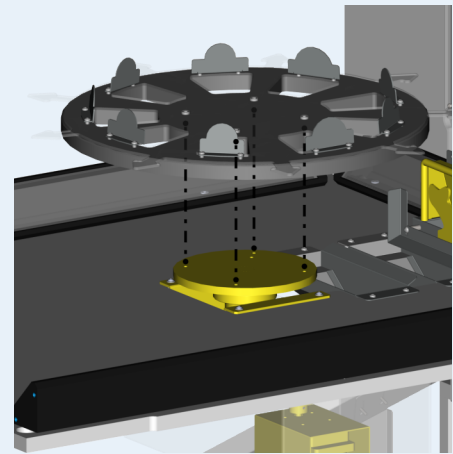
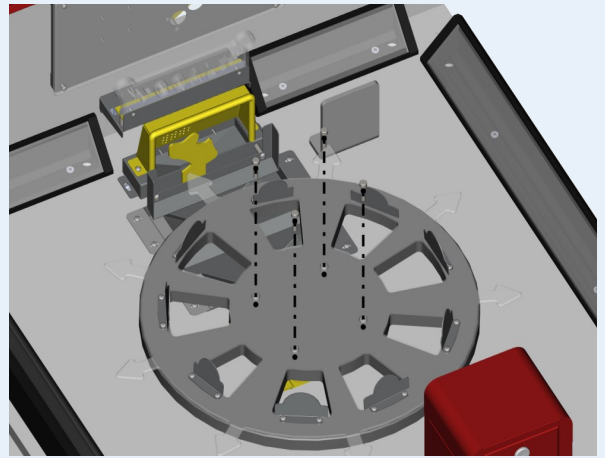

Score Switches

Located underneath the playfield are the switches that register the score zone the coins fall into. The switches are part number PK2000AE and two are needed for each zone. Below shows how they are mounted. They are accessed through the side service doors.

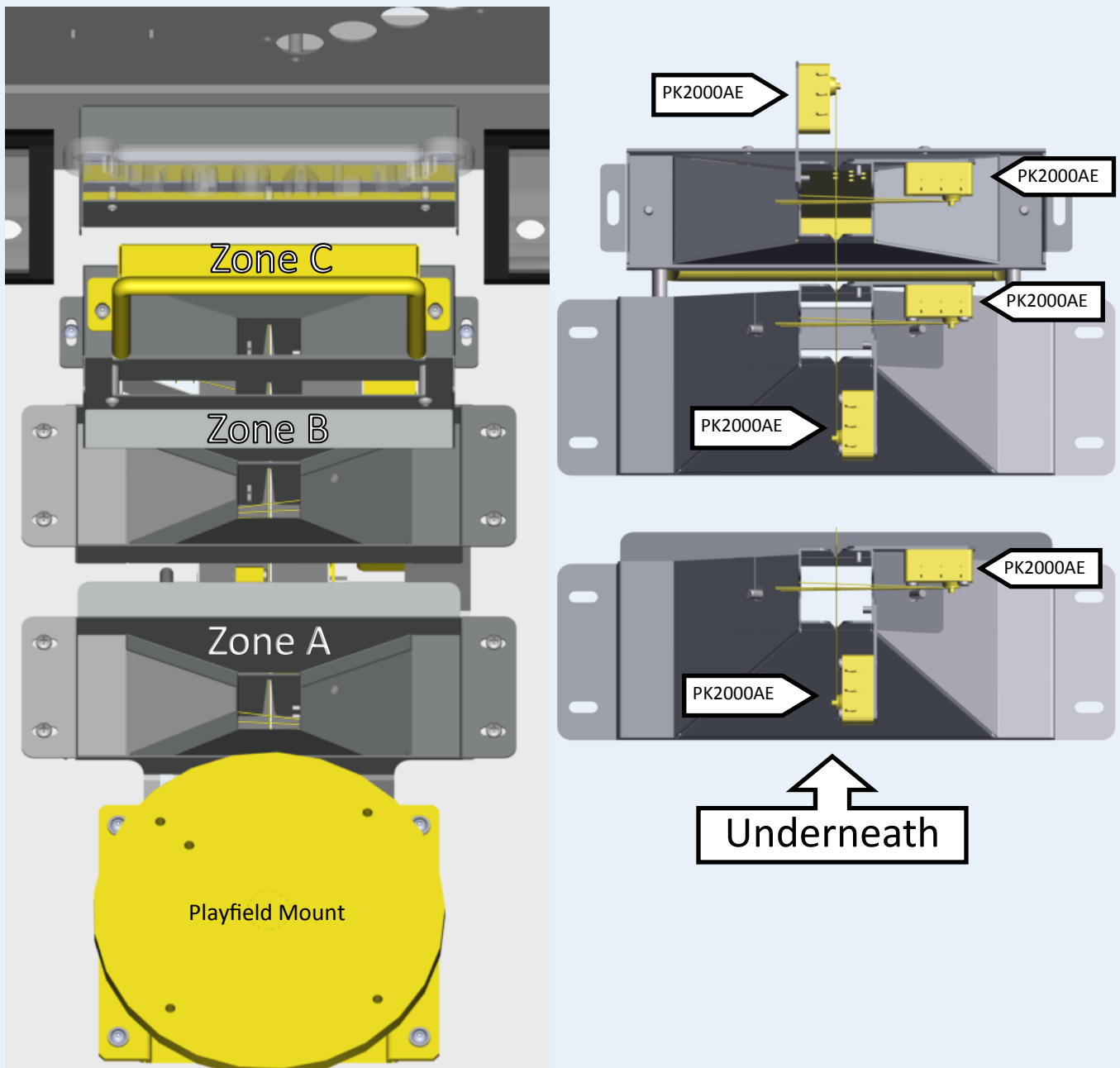

Service Access

Located on the right side of the cabinet through it's service access door is the main power supply. On the left side you will find through the service access door the main circuit board. Finger guards are installed around the playfield gear assembly and goalie assembly. To service these two areas remove the finger guards. From the back service door you can access the goalie assembly and displays.

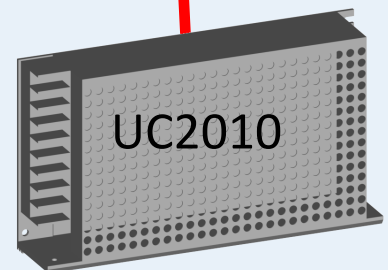
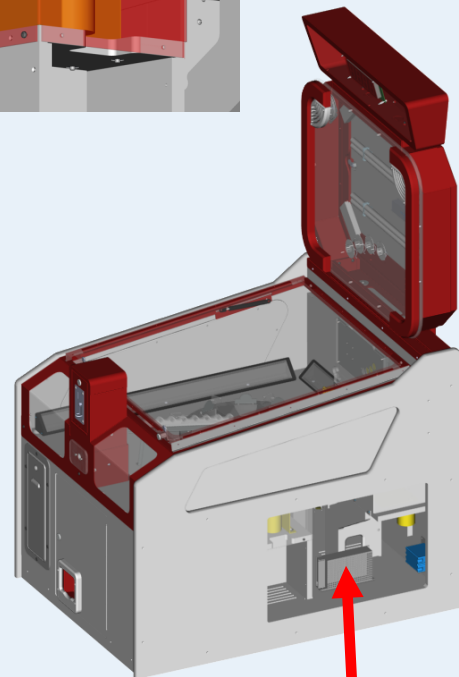
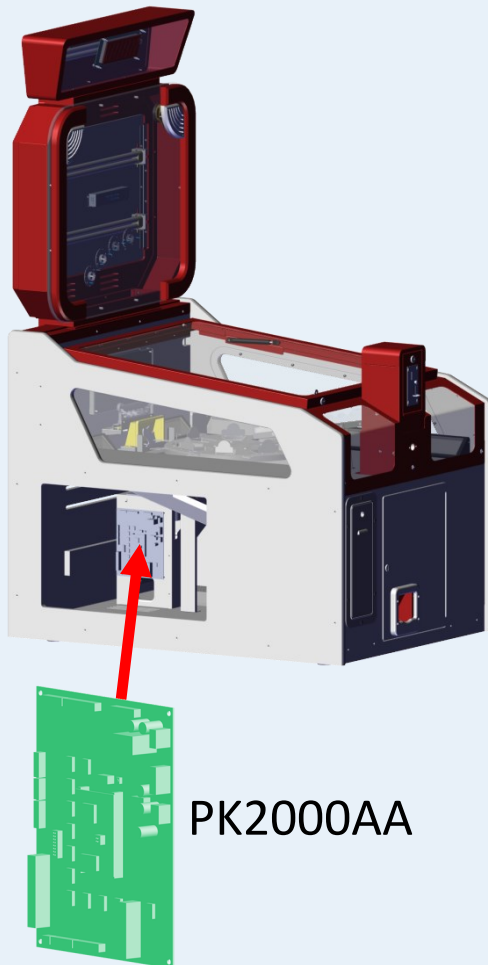
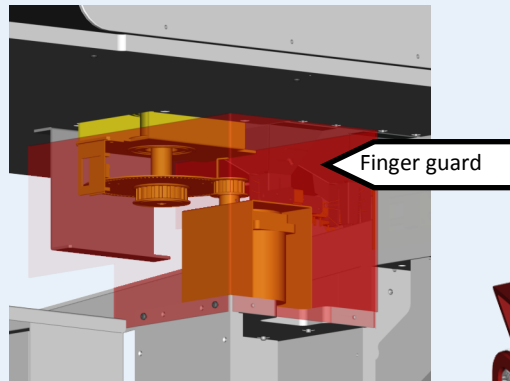
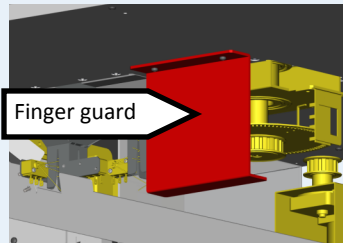

Power supply - UC2010 ; Set input voltage before use!!

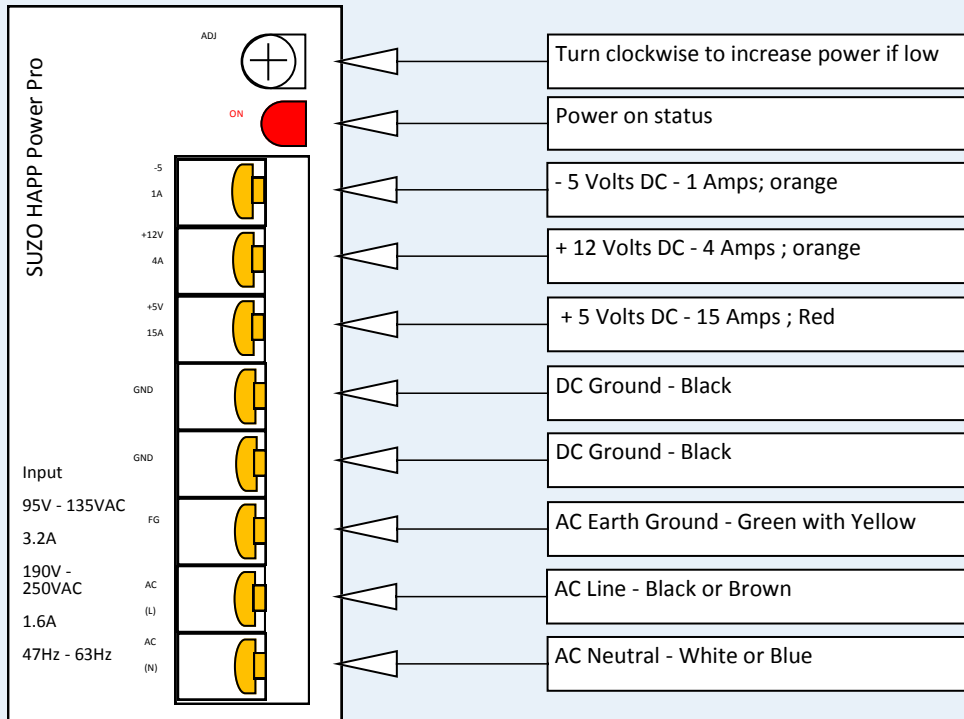

Checking DC Voltages

Volt test with the volt meter set to DC voltage. The +5 output can be adjusted by turning the adjustment screw of the power supply. Adjust to as close to +5 as possible. The voltage range can be plus or minus 5%. +12 and -5 increases as +5 is increased.

Positive Probe:
Connect to

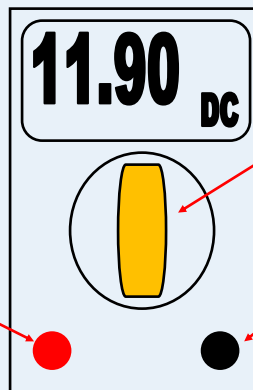

Turn to DC
voltage

Ground Probe:
Connect to

General Illumination

Attached to the upper back door are two PLL 40watt bulbs that provide general lighting. There is a single PLL 40 watt bulb mounted to the back of the upper marquee panel. To replace a bulb remove the plastic clip first and then push the red button to eject the bulb from the holder. Insert the replacement bulb back into the socket until a click is heard. Be sure to replace the bulb clip or the bulb can fall out.

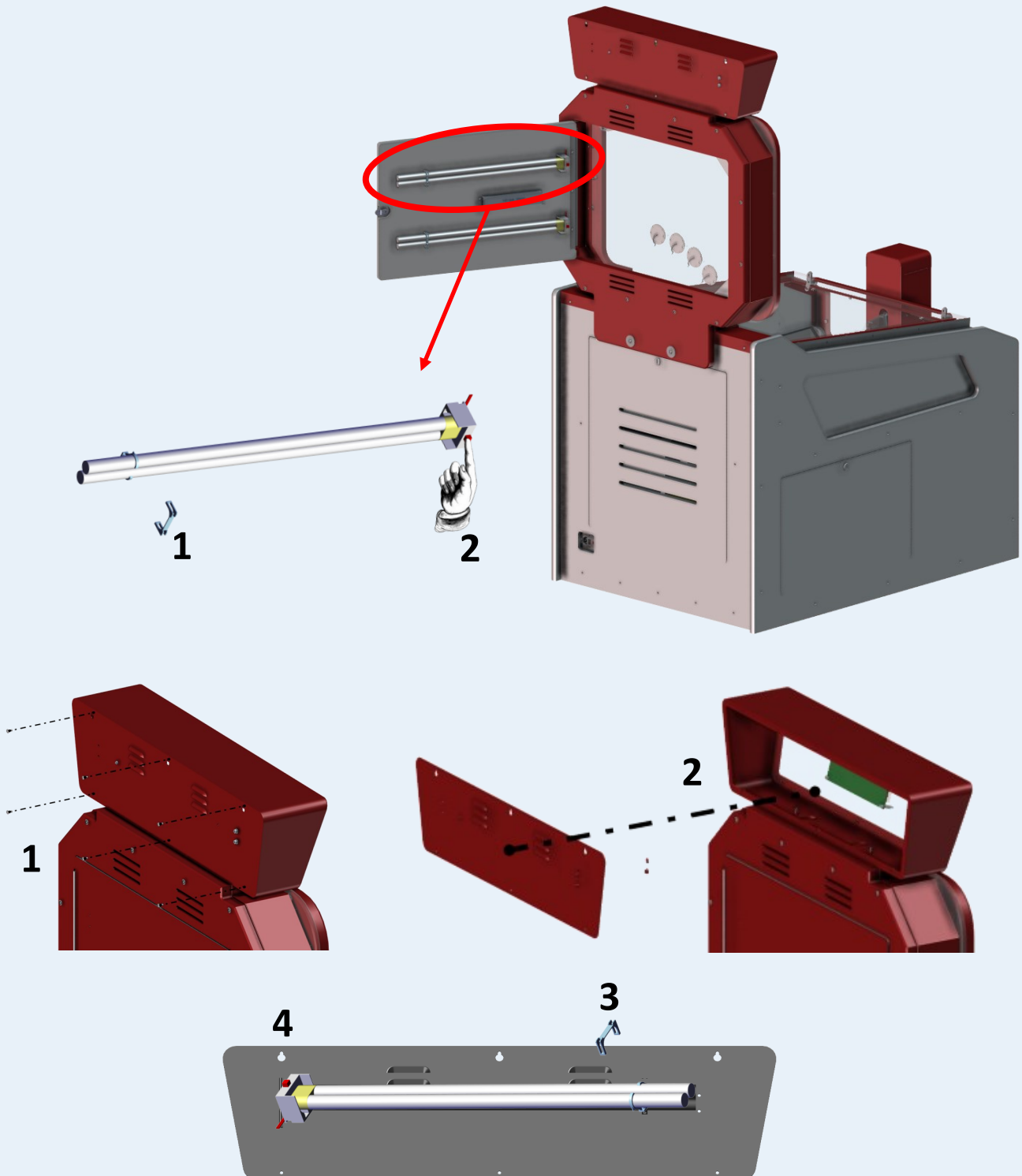

Goalie Motor replacement

To replace the goalie motor assembly open the back access door. Remove the snap ring that attaches the control arm to the motor assembly. Swing arm out of the way. Remove the screw holding the cam and lift up. Under the cam there are four mounting screws that hold the gearbox to the goalie mount plate. Remove the screws and the motor assembly can be removed. Replace in reverse.

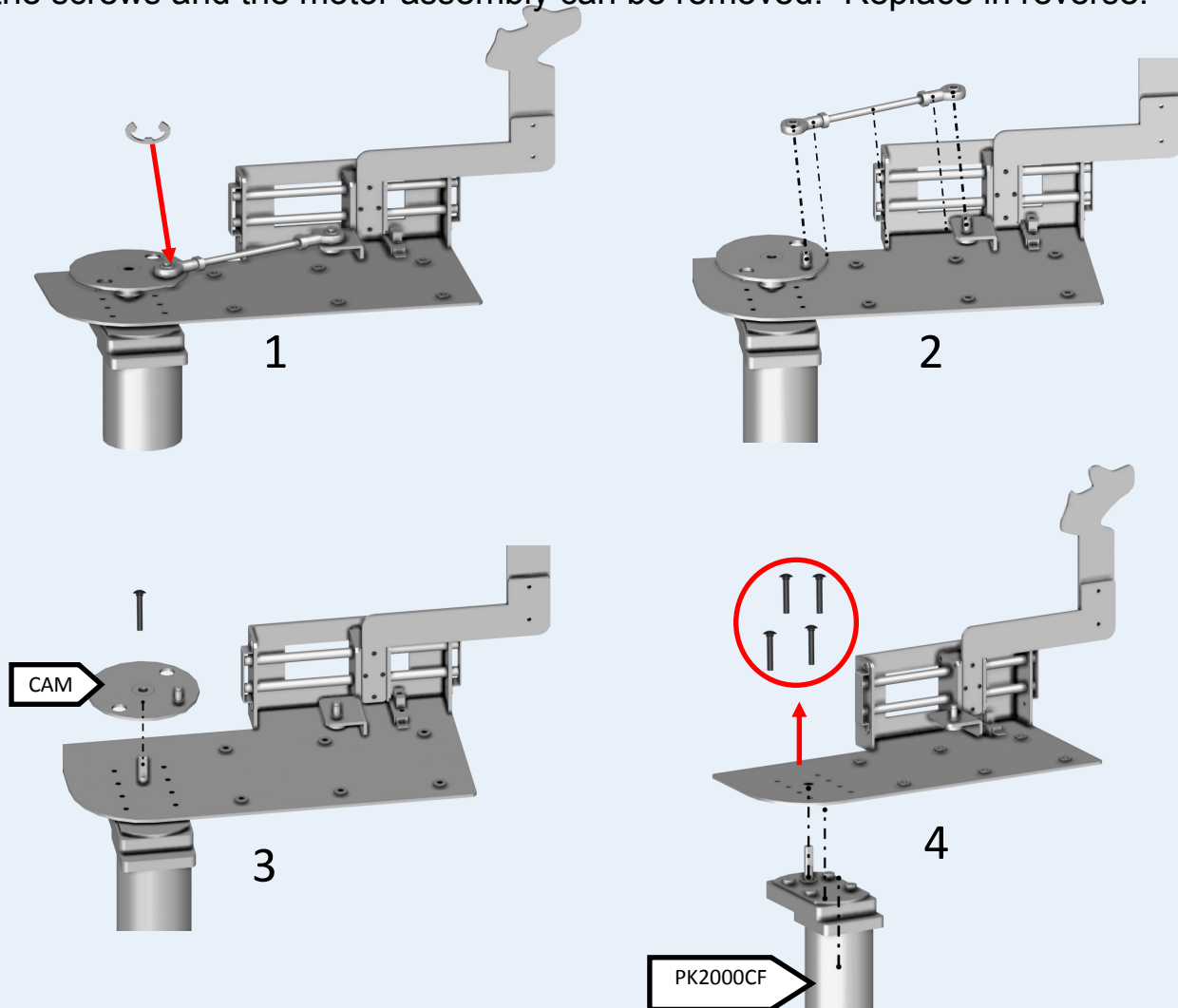

Goalie Sensor

The goalie slides back and fourth and as it travels it blocks the PK2000CG sensor. When defective it will cause an error 2 and interrupt the game from play.

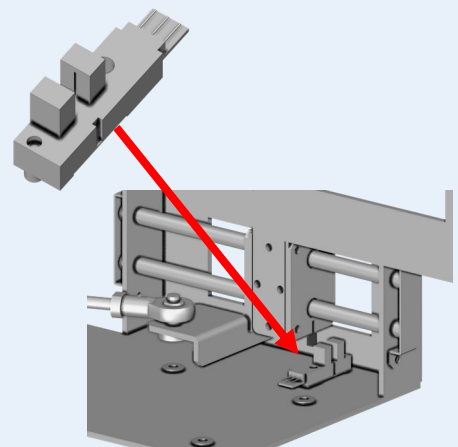

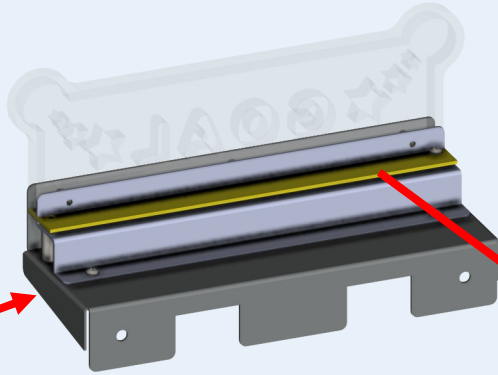
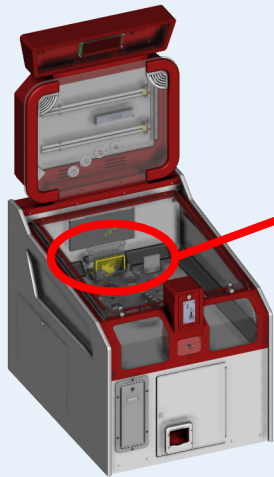

PK2000AC



PK2000AD

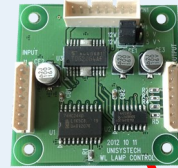

PK2000AF



E00668

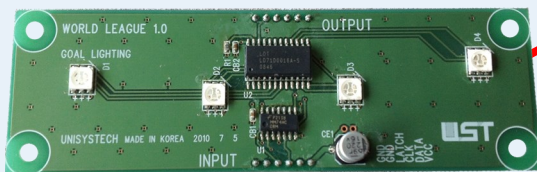
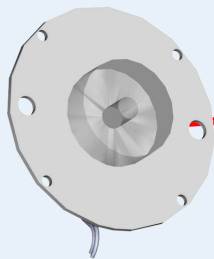

PK2000AB

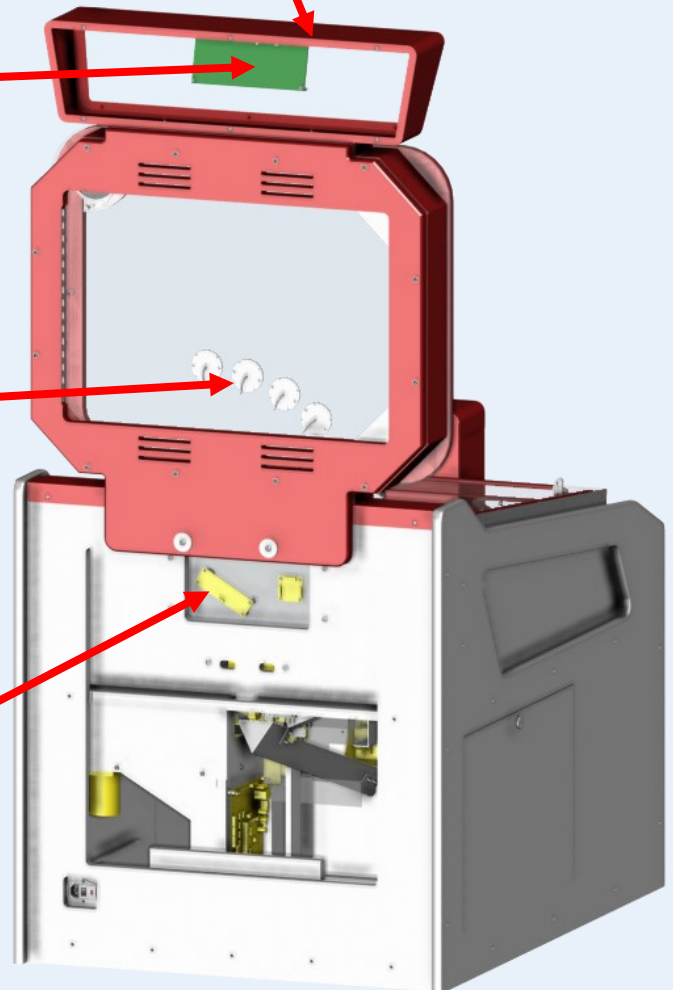

Spare Parts list

Mechanical Parts

AA0201	Chrome T-molding (sold by the foot)
AA0227	Roll Down mech
BW2017	Plastic Clip
HR1019	Leveler foot white
MJ3335	Finger guard
MT1024	Ticket bin
PK1009	Cash box
PK1052	Gas shock
PK2000BC	Rotary playfield motor w/gearbox
PK2000CF	Goalie keeper motor w/gearbox

Electrical Parts

E00418PKAX	White 57 LED strip
E00418PKX White	12 LED strip
CG2027	Power cord
E00764	3 W LED flood bulb
E08312	PL-L 40W/41/RS/IS Florescent bulb
FP2007	Speaker
HH5005CL	Ticket Dispenser (CLE)
PK2000AA	Main board
PK2000AE	Zippy switch
PK2000CG	Goalie sensor
PK2000DG	Playfield sensor
PK2000AF	Large Jackpot display
PK8384X	Ballast Wh5
TX2007X	Power module 5 amp
UC2010	Power supply

Decal Parts

PK7032	Goal Sign Numbers
PK7034	Ref Numbers
PK7035	Goal Keeper
PK7088 A thru E	Defenders 1 thru 5



WARRANTY POLICY

I.C.E. Inc. warrants all components in new machines to be free of defects in materials and workmanship for the period listed below:

- 180 days on Main PCB's, Computers & Motors
- 1 year on all LCD monitor panels
- 90 days on all other electronic and mechanical components
- 30 days on all I.C.E. repairs and parts purchases

I.C.E. Inc. shall not be obligated to furnish a warranty request under the following conditions:

- Equipment or parts have failed through normal wear and tear
- Equipment has been subjected to unwarranted stress, abuse or neglect
- Equipment has been damaged as a result of arbitrary repair/modification

Products will only be covered under warranty by obtaining an I.C.E. authorized RMA #. To obtain an RMA # please provide I.C.E. tech support with the game serial # or original I.C.E. invoice # and a detailed description of the failure or fault symptoms.

I.C.E. Inc will assume no liability whatsoever for costs associated with labor or travel time to replace defective parts. All defective warranty covered components will be replaced with new or factory refurbished components equal to OEM specifications.

I.C.E. Inc will cover domestic UPS ground, or comparable shipping costs during the warranty period. International or expedited shipments are available for an additional charge. To obtain credit defective parts must be returned to I.C.E. Inc, at the customer's expense, within 30 days. After 30 days a 15% re-stocking fee will apply to all returns.

ICE distributors are independent, privately owned and operated. In their judgment, they may sell parts and/or accessories other than those manufactured by I.C.E. Inc. We cannot be responsible for the quality, suitability or safety of any non-I.C.E. part or modification (including labor) that is performed by such a distributor.

Innovative Concepts in Entertainment
10123 Main St.
Clarence, NY 14031
Phone #: (716) - 759 - 0360
Fax #: (716) - 759 - 0884