

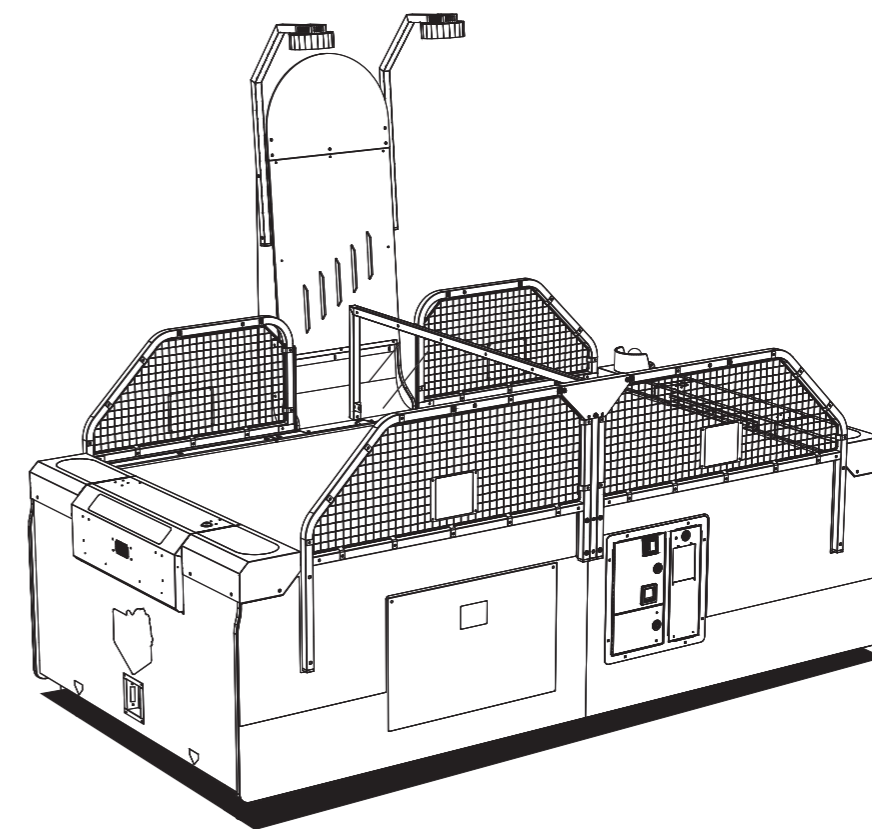

Entertainment



PAC-MAN SMASH SLIM LINE

Operation Manual

The actual product may differ slightly from the illustrations in this Operation Manual.

PAC-MAN SMASH SLIM LINE

Operation Manual

First Edition

BANDAI NAMCO Entertainment Inc.

Part No.: 742-223
First edition issued
November 2016

WARNING

- To ensure safe operation of the machine, be sure to read this Operation Manual before use.
- Keep this Operation Manual in a safe place for quick access whenever needed.

Introduction

Thank you very much for purchasing PAC-MAN SMASH SLIM LINE (referred to as “the machine” in this manual).

This Operation Manual describes:

- How to safely install, move, transport, operate, service and dispose of the machine.
- How to make full use of the machine's functions and operate it correctly.
- How to ensure the safety of players and bystanders.

Contact for this machine and machine repair inquiries

- For inquiries regarding the machine or machine repairs, contact your distributor.

1. Safety Precautions

-Be sure to read to ensure safe operation-

Instructions to the Owner

If you delegate the work for installing, moving, transporting, operating, servicing or disposing the machine to other people, ensure that these people read the relevant sections of this operation manual carefully before starting work, and observe the corresponding precautions.

1-1 Levels of Risk

The safety and property damage precautions on the machine labels and in this Operation Manual are classified according to their risk level, as follows.

 **WARNING** : Failure to avoid these risks may result in serious injury or death.

 **CAUTION** : Failure to avoid these risks may result in light injury or damage to other property.

Notes about functionality that are not linked to safety are indicated with the following symbol.

 **NOTICE** : Information about product functions or protection.

1-2 Definition of “Technician”

This Operation Manual is designed for arcade personnel. However, the sections marked “Must be performed by a technician” in the Table of Contents are written for technicians. These tasks must be performed by technicians only.

Technician: A person involved in design, manufacture, inspection or service at an amusement device manufacturer, or a person involved routinely in the service or management (such as repair) of amusement devices and who has specialist knowledge of electricity, electronics or mechanical engineering equivalent to or higher than a technical high school graduate.

1

2

3

4

5

6

7

8A

8B

9

10

11

12

Levels of Risk / Definition of “Technician”

Test Mode

Troubleshooting

1-3 Critical Safety Precautions

WARNING

- Should an abnormality occur, turn off the power switch immediately to stop operations. Then, be sure to disconnect the power cord plug from the outlet. Operating the machine while the abnormality persists may result in a fire or accident.
- This machine includes important parts used to ensure the safety of players and bystanders. Operating the machine while these “important parts for ensuring player and bystander safety” are broken, damaged or deteriorated, or with defective installation may result in an injury to the players or bystanders. If you discover an abnormality, replace the affected part immediately. To order parts, contact your distributor.
- Dust accumulating on the power cord plug may result in a fire. Inspect the plug regularly and remove any dust.
- Fully insert the power cord plug into the outlet. Poor contact may generate heat and result in a fire or burns.
- Damage to the power cord may result in a fire, electric shock or electrical leakage. Be sure to observe the following.
 - Keep the power cord away from heaters.
 - Do not twist the power cord.
 - Do not forcibly bend the power cord.
 - Do not alter the power cord.
 - Do not pull the power cord. (Always unplug by holding the plug and not the power cord.)
 - Do not bundle the power cord.
 - Do not place objects on the power cord.
 - Do not allow the power cord to be caught between the machine and other devices or the wall.
 - Do not do anything else that might damage the power cord.
- Do not expose the power cord and power cord plug to water. It may result in electric shock or electrical leakage.
- Do not touch the power cord plug with wet hands. It may result in electric shock.
- The power capacity of the machine is AC 120 V (or 230 V), maximum current consumption 5 A. To prevent fire and electric shock, use indoor wiring that conforms to these power supply specifications.
- Using a voltage outside this range may result in a fire or electric shock. However, to ensure that the machine operates in the optimum condition, keep the voltage at AC 120 V (or 230 V) as much as possible.
- To ensure safe use of the machine, be sure to perform the pre-operation inspection (See “7-4 Pre-operation Inspection” on page 35.) and service (See “8B Service” on page 89.). Omitting these inspections or service may result in an accident.
- Use the consumables and service parts (including screws) that are specified by BANDAI NAMCO Entertainment Inc. To order parts, contact your distributor.
- Do not modify the machine without permission. Do not perform any operations that are not described in this Operation Manual. Modifying the machine may create unforeseen hazards.
- If you decide to transfer ownership of this machine, be sure to provide this Operation Manual with the machine
- This appliance can be used by children aged from 8 years and above and persons with reduced physical, sensory or mental capabilities or lack of experience and knowledge if they have been given supervision or instruction concerning use of the appliance in a safe way and understand the hazards involved.
- Children shall not play with the appliance.
- Cleaning and user maintenance shall not be made by children without supervision.
- Warning - disconnect the appliance from its power source during service and when replacing parts.
- The appliance must not be cleaned by a water jet.

1-4 Machine Warning Labels

WARNING

- The warning labels attached to the machine contain important information for ensuring safety. Be sure to observe the following.
 - To ensure that the warning labels attached to the machine are always clearly visible, install the machine in an appropriate location with ample illumination and keep the labels clean at all times. Make sure that the labels are not hidden by other machines or objects.
 - Do not remove or alter the warning labels.
 - If a warning label becomes excessively dirty or damaged, replace it with a new one. To order warning labels, contact your distributor.

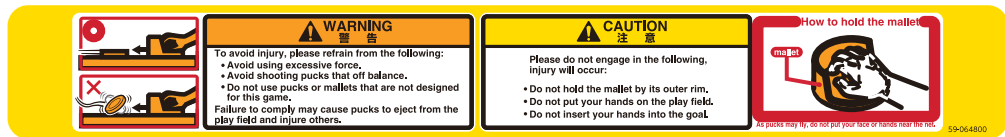

Warning sticker Goal (EXP)
Part No.: 461-851

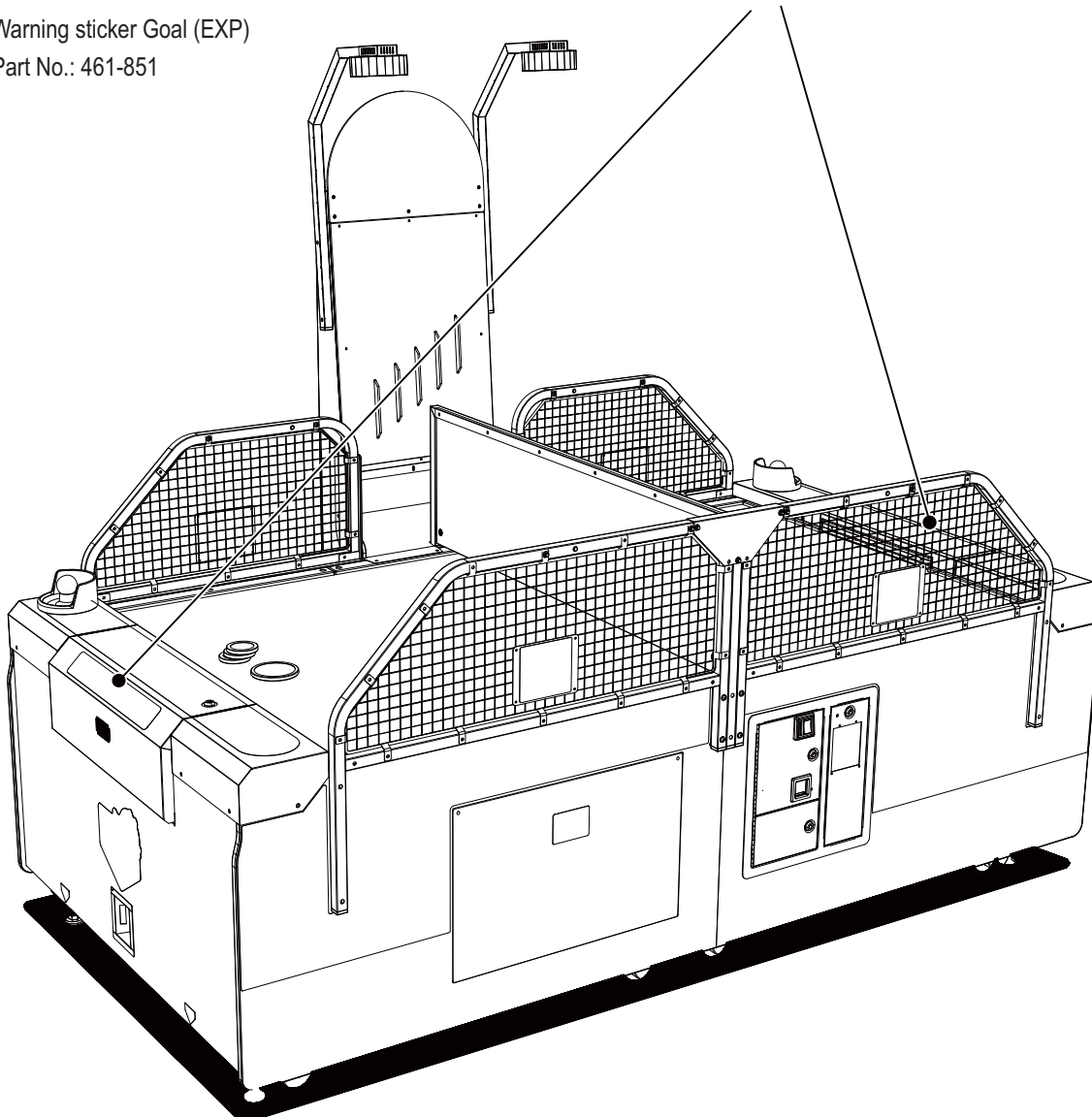

1

2

3

4

5

6

7

8A

8B

9

10

11

12

Critical Safety Precautions / Machine Warning Labels

Test Mode

Troubleshooting

1. Safety Precautions -Be sure to read to ensure safe operation-

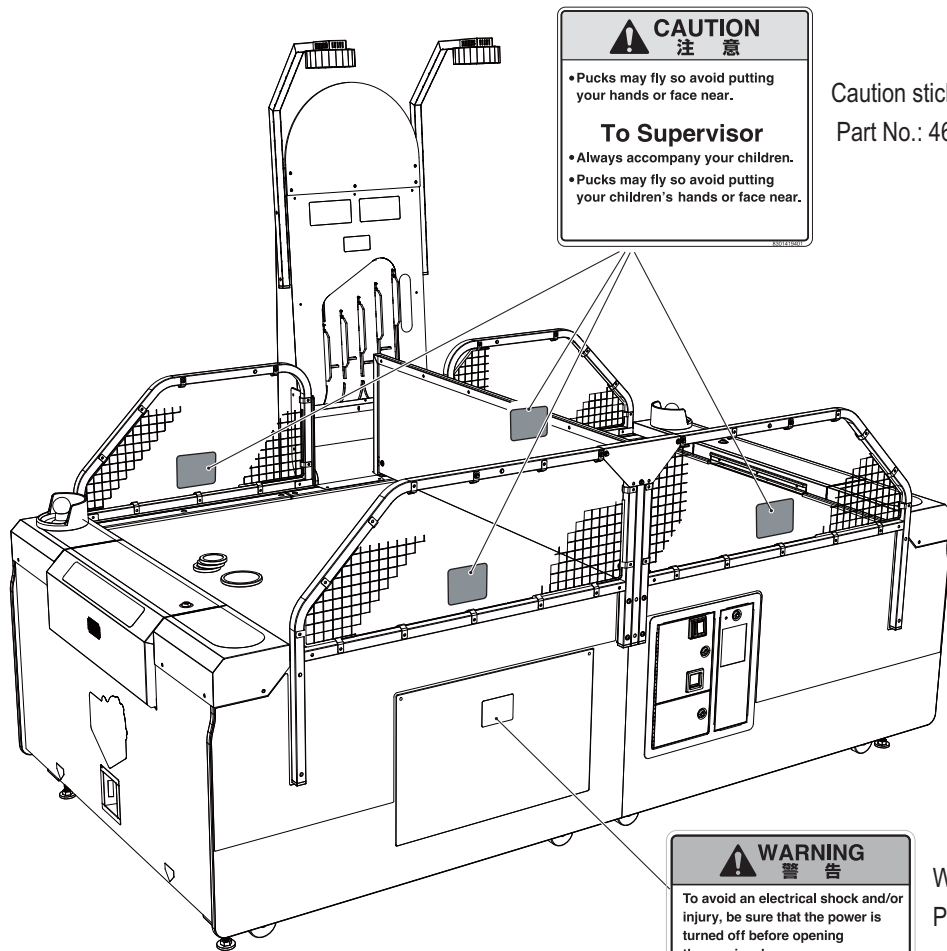

Caution sticker Do Not Approach Net (EXP)
Part No.: 461-771

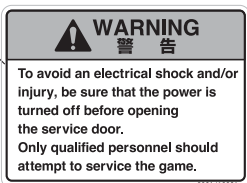

Warning sticker Service B (EXP)
Part No.: 461-539

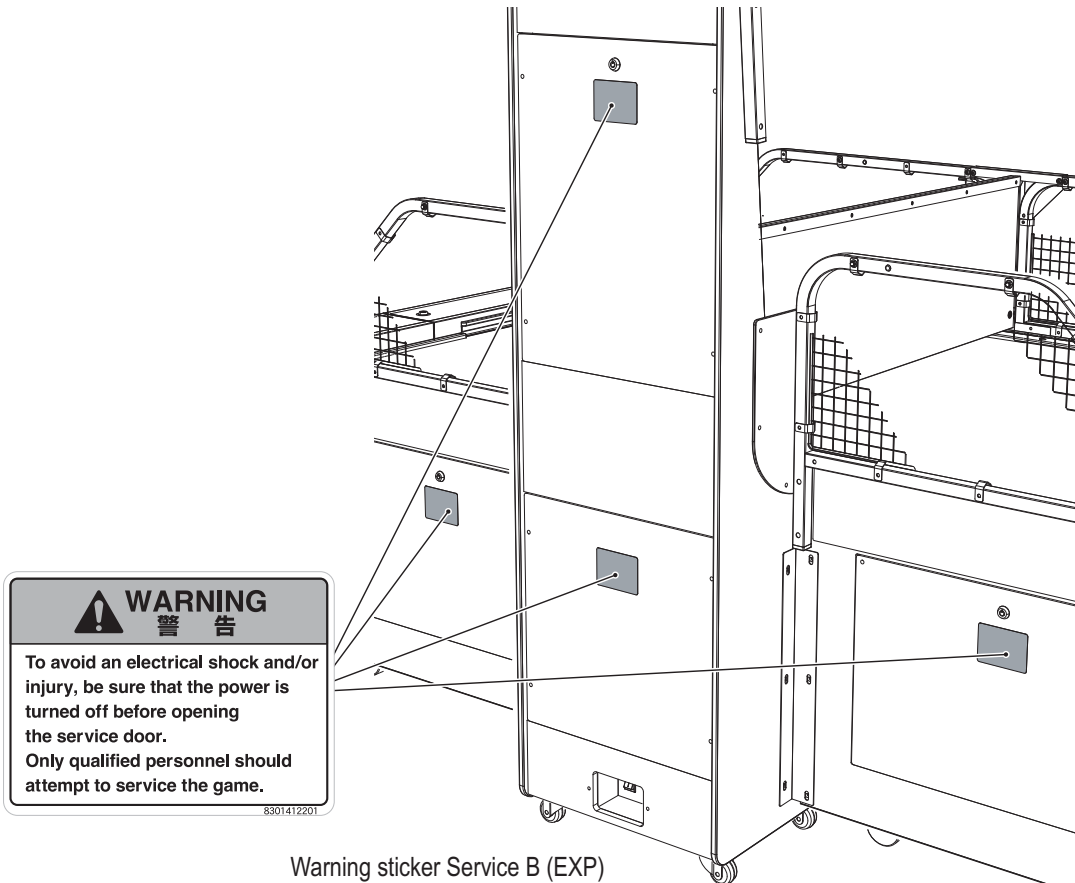

Warning sticker Service B (EXP)
Part No.: 461-539

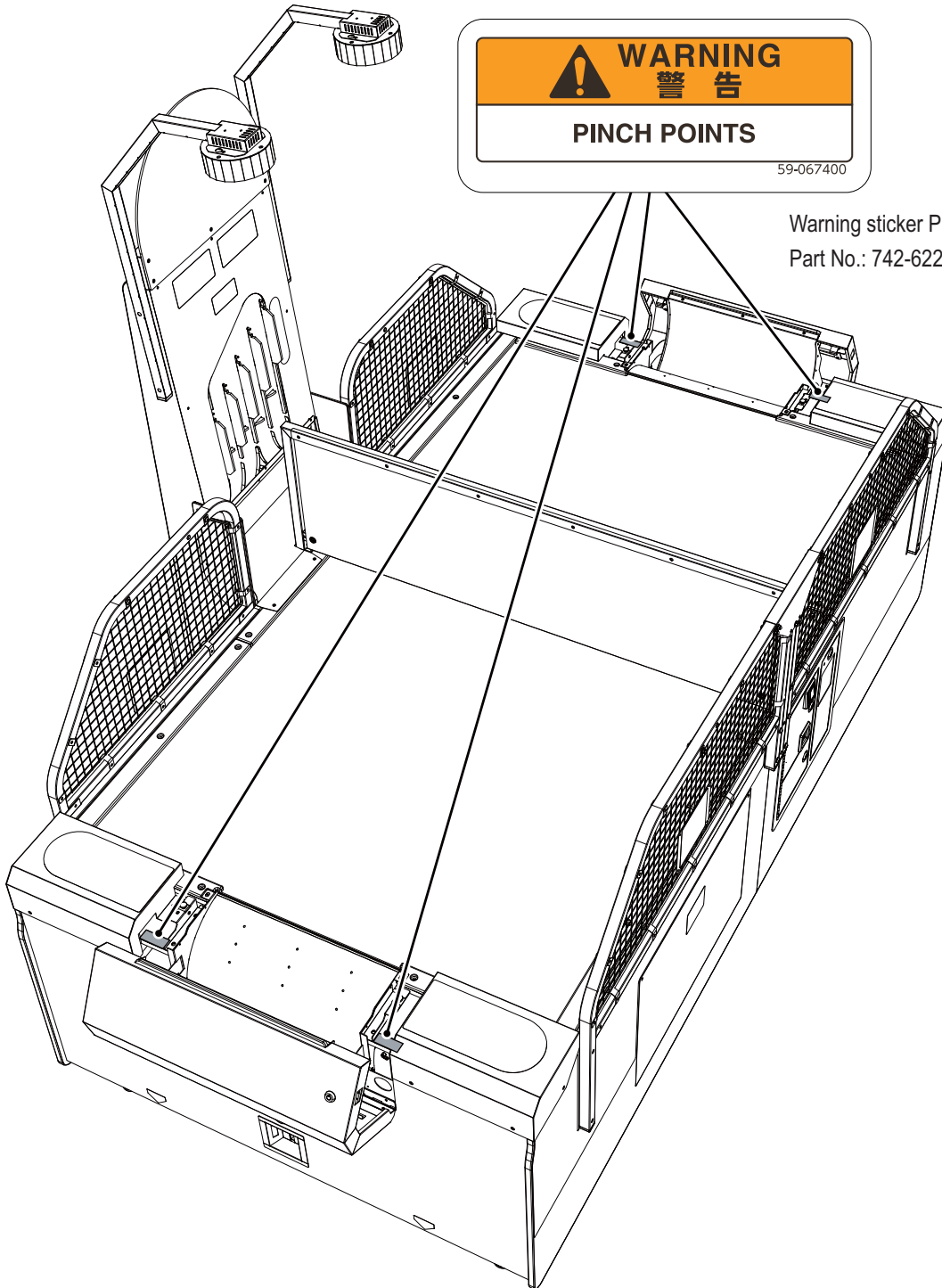

1

2

3

4

5

6

7

8A

8B

9

10

11

12

Levels of Risk / Definition of "Technician"

Test Mode

Troubleshooting

Table of Contents

Introduction

1. Safety Precautions -Be sure to read to ensure safe operation-	1
1-1 Levels of Risk	1
1-2 Definition of "Technician"	1
1-3 Critical Safety Precautions	2
1-4 Machine Warning Labels	3
2. Specifications	10
3. Package Contents	13
4. Overall Structure (Part Names)	22
5. Installation	24
5-1 Installation Conditions	24
5-1-1 Installation Locations to Avoid.....	24
5-1-2 Play Zone for the Installed Machine.....	25
5-2 Required Dimensions for the Delivery Route (Such as Doors and Corridors).....	26
6. Moving and transporting	27
6-1 Moving (On the Same Floor)	27
6-2 Transporting.....	28
6-2-1 Transporting Manually (Such as Carrying on Stairs)	28
6-2-2 Loading and Unloading to and from a Vehicle	30
6-2-3 Transporting on a Vehicle	31
7. Operation	32
7-1 People Who Should Avoid Playing	33
7-2 Safety Precautions for Playing	33
7-3 Important Parts for Ensuring Player and Bystander Safety	34
7-4 Pre-operation Inspection	35
7-4-1 Safety Inspection Items (Before Power On).....	35
7-4-2 Function Inspection Items (After Power On)	36
7-5 Opening and Closing Doors	37
7-5-1 Opening and Closing the Selector Door	37
7-5-2 Opening and Closing the Coin Box Door	37
7-5-3 Opening and Closing the Goal (L) and (R) Assemblies	38
7-6 Explanation of the Power Switch and Adjustment Switches	39
7-6-1 Turning the Power Switch On	39
7-6-2 Adjustment Switches.....	39
7-7 Playing the Game	40
7-7-1 Starting the Game and Game End.....	40
7-8 Test Mode	41
7-8-1 Test Item Selection Mode.....	41
7-8-2 Score LED, Time LED , Stocker LED, Goal LED, and L outlet LED Test.....	42
7-8-3 Switch Input Test.....	43
7-8-4 Blower Fan ON/OFF Test and Sensor Check	45
7-8-5 Solenoid ON/OFF Test and Sensor Check	46
7-8-6 S Hopper Motor ON/OFF Test and Sensor Check	47
7-8-7 Sound Test	48
7-9 Setting Mode	49
7-9-1 Setting Item Selection Mode	49
7-9-2 Number of coins per game.....	51
7-9-3 Number of plays per game.....	52

7-9-4	Play time	53
7-9-5	Setting of the random time for the mini puck	54
7-9-6	Setting of the last time for the mini puck	55
7-9-7	Attract BGM ON/OFF	56
7-9-8	Error log	57
	(1) Number of Errors Saved in Error Log Display Mode	57
	(2) Error Log Contents Display Mode	58
7-9-9	Return all settings to default settings (factory settings)	59
7-10	Checking the Number of Big Pucks and Adding Big Pucks	60
7-11	Daily Cleaning	61
7-11-1	Cleaning the Playing Field	61
7-11-2	Cleaning the Goal Covers and Corner Covers	62
7-11-3	Cleaning the Pucks and Mallets.....	62
7-11-4	Cleaning the Signboard and Cover Panel.....	63
7-11-5	Cleaning the Sloped Areas	64
8.	Technician's Manual - Must be performed by a technician -.....	65
8A.	Installation and Assembly.....	65
8A-1	Number of Workers, Work Time and Work Space.....	65
8A-1-1	Number of Workers and Work Time.....	65
	(1) Number of Workers	65
	(2) Work Time	65
8A-1-2	Securing Work Space	65
8A-2	Assembly.....	66
8A-2-1	Assembling the Table.....	66
	(1) Assembling the Table, Goals and Corner Covers	66
	(2) Installing the Nets	73
	(3) Installing the Blower Fan	76
8A-2-2	Level Adjuster Adjustment.....	77
8A-2-3	Assembling the Side Tower Assembly	78
8A-2-4	Installing the Light Assembly.....	79
8A-2-5	Installing the Side Tower Assembly.....	81
8A-2-6	Preparing the Pucks and Mallets	85
8A-3	Connecting the Power Cord and Ground	86
8A-4	Checks after Installation	86
8A-5	Opening and Closing Doors	87
8A-5-1	Opening and Closing the Front Doors	87
8A-5-2	Opening and Closing the Service Doors L and R	87
8A-5-3	Opening and Closing the Rear Panel	88
8A-5-4	Opening and Closing the Service Door.....	88
8B.	Service - Must be performed by a technician -.....	89
8B-1	Inspection and Service	89
8B-1-1	Inspection Items.....	89
8B-1-2	Cleaning the Puck Paths.....	90
	(1) Cleaning the Insides of the Goal (L) and (R) Assemblies.....	90
	(2) Cleaning the Rail (L) and (R) Assemblies.....	91
	(3) Cleaning the Inside of the S Bucket (Hopper Assembly).....	92
	(4) Cleaning the S Hopper Disk and S Hopper Bottom (Hopper Assembly).....	93
	(5) Cleaning the Slider Assembly.....	96
8B-1-3	Removing Jammed Pucks	98

- 1
- 2
- 3
- 4
- 5
- 6
- 7
- 8A
- 8B
- 9
- 10
- 11
- 12

- Test Mode
- Troubleshooting

Table of Contents

	(1) Inside the Goal (L) or (R) Assembly	98
	(2) In case of the rail (L)/(R) assembly.....	98
	(3) Inside the S Bucket (Hopper Assembly)	99
	(4) Inside the S Hopper Disk or S Hopper Bottom (Hopper Assembly)	99
	(5) In case of S Escalator Assembly	100
	(6) In case of the Slider Assembly	101
8B-1-4	Adding Big Pucks	102
8B-2	Error Display (for Technicians).....	103
8B-2-1	Display when an Error Occurs	103
8B-2-2	Resolving Errors	103
8B-3	Troubleshooting	108
8B-3-1	Overall.....	109
8B-3-2	Table Top Assembly	109
8B-3-3	Goal (L) and (R) Assemblies.....	110
8B-3-4	Rail (L) and (R) Assemblies	110
8B-3-5	Coin Assembly	110
8B-3-6	S Hopper Assembly	111
8B-3-7	Slider Assembly	112
8B-3-8	S Escalator Assembly	112
8B-3-9	L Outlet Assembly	113
8B-3-10	Light Assembly.....	113
8B-4	Removing, Installing and Replacing Assemblies and Parts.....	114
8B-4-1	Table	114
	(1) Removing and Installing the Goal (L) and (R) Assemblies	114
	(2) Replacing the Blower Fan	116
8B-4-2	Goal (L) and (R) Assemblies.....	118
	(1) Replacing the Goal (L) and (R) Sensors (Photosensor Side) and (Photo-emitter Side)	118
	(2) Replacing the Goal (L) and (R) Illumination PC Board.....	119
8B-4-3	Rail (L) and (R) Assemblies	121
	(1) Replacing the Rail (L) and (R) Sensors (A), (B) and (C)	121
	(2) Replacing the L Stopper (L) and (R) Sensors.....	123
	(3) Replacing the L Stopper (L) and (R) Solenoids.....	124
8B-4-4	Side Tower Assembly.....	125
	(1) Removing and Installing the Side Tower Assembly	125
	(2) Replacing the Main PC Board	126
	(3) Replacing the Switching Regulator.....	128
	(4) Replacing the SSR	130
8B-4-5	S Hopper Assembly	131
	(1) Replacing the S Hopper Motor	131
	(2) Replacing the S Hopper Motor Sensor.....	134
8B-4-6	Slider Assembly	135
	(1) Replacing the S Stopper Solenoid.....	135
	(2) Replacing the S Stopper Sensor	136
	(3) Replacing the Time LED (Time LED PC Board).....	137
	(4) Replacing the Score LED (Score LED PC Board).....	138
	(5) Replacing the S Stocker LED	139
	(6) Replacing the S Escalator Outlet Sensor	141
8B-4-7	L Outlet (L) and (R) Assemblies.....	142
	(1) Replacing the L Outlet (L) and (R) Sensors.....	142
	(2) Replacing the L Outlet LED PC Board.....	144

8B-4-8 Light Assembly	145
(1) Replacing the Light LED PC Board	145
9. Disposal	147
10. Parts List.....	148
10-1 Overall	148
10-2 Table top assembly	150
10-3 Cabinet (L) assembly.....	151
10-4 Goal (L) assembly	153
10-5 Rail (L) assembly.....	155
10-6 Cabinet (R) assembly	157
10-7 Goal (R) assembly	159
10-8 Rail (R) assembly	161
10-9 Side tower assembly	163
10-10 S Hopper assembly	166
10-11 Slider assembly	169
10-12 S escalator assembly	171
10-13 Coin cabinet assembly	173
10-14 Signboard assembly	175
10-15 Cord box assembly.....	175
10-16 L outlet assembly.....	176
10-17 Light assembly.....	177
11. Wiring Diagram.....	178

- 1
- 2
- 3
- 4
- 5
- 6
- 7
- 8A
- 8B
- 9
- 10
- 11
- 12

- Test Mode
- Troubleshooting

2. Specifications

- | | |
|---------------------------------|--|
| (1) Rated power supply | AC 120 \pm 10 V (60 Hz) , AC 230 \pm 10 V (50 Hz) , 220 \pm 10V (50 / 60 Hz) |
| (2) Rated power consumption | 300 W |
| (3) Maximum current consumption | 3 A |
| (4) Cashbox capacity | Approx. \$625 (2,500 \$.25 coins)
£1,500 (1,500 £1 coins) |
| (5) Dimensions | |
| 1) When installed | Width (W) 1,510 x Depth (D) 2,450 x Height (H) 2,100 [mm] |

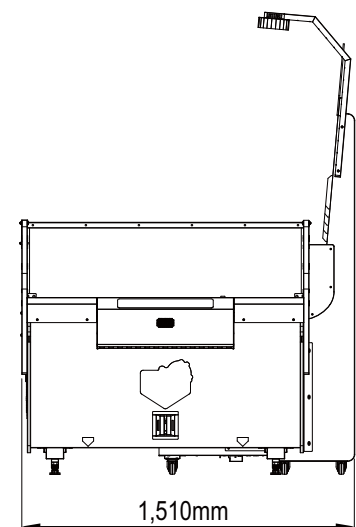
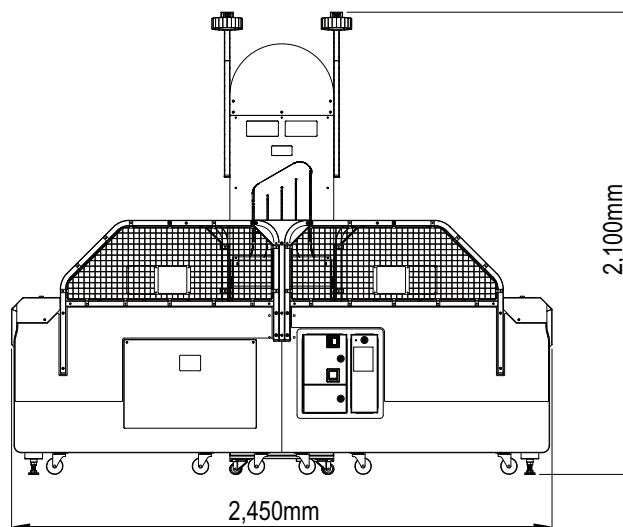
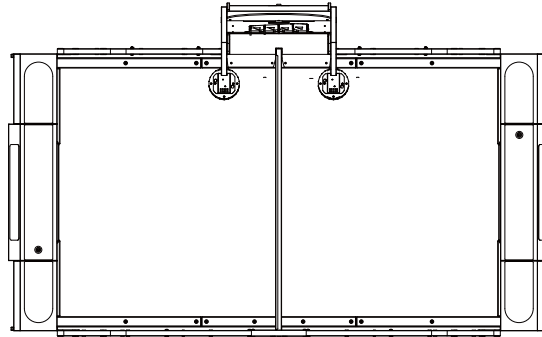

2) When disassembled

Table

Width (W) 1,300 x Depth (D) 2,450x Height (H) 1,150 [mm]

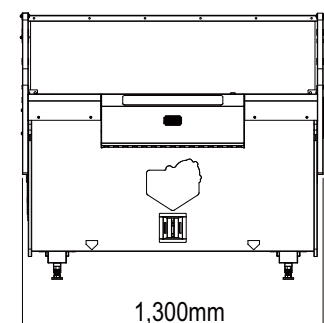
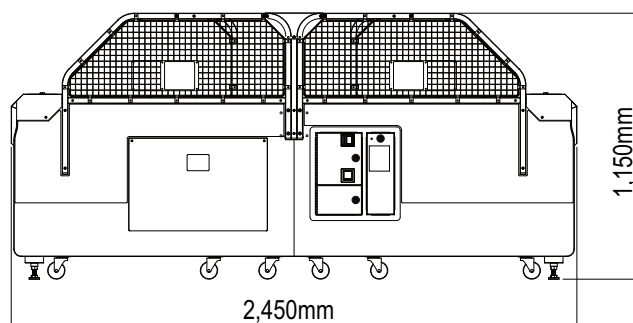
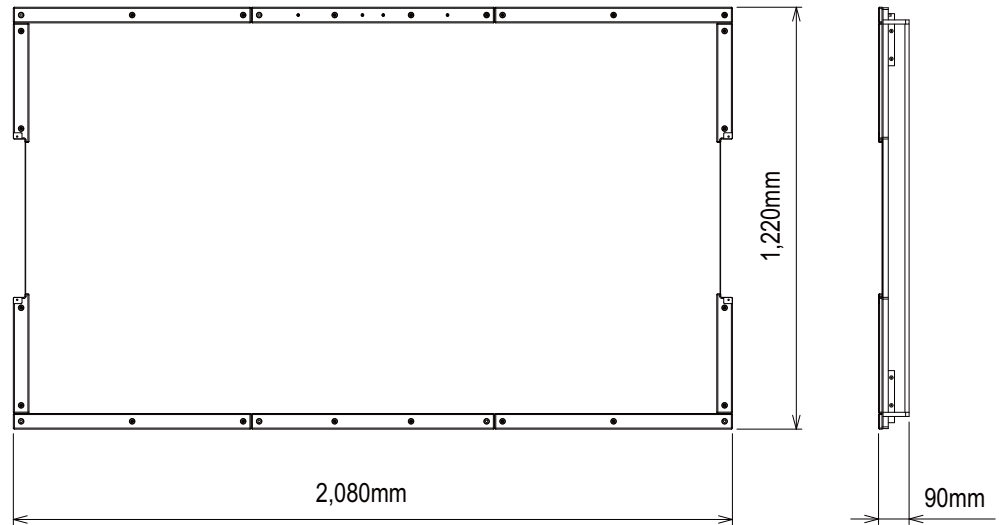
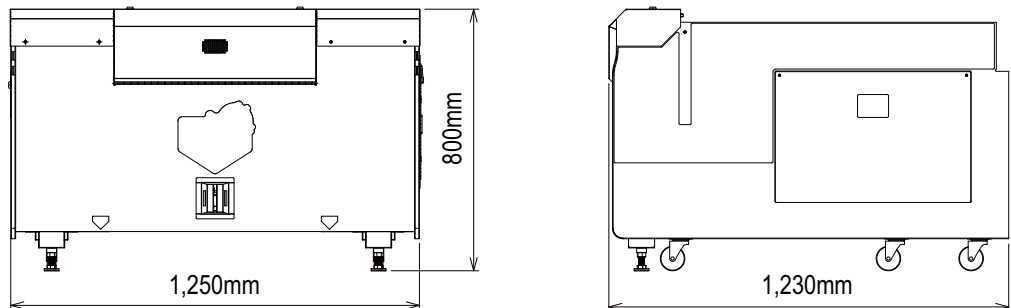

Table top assembly Width (W) 1,220x Depth (D) 2,080 x Height (H) 90 [mm]



Cabinet (L) assembly Width (W) 1,250 x Depth (D) 1,230 x Height (H) 800 [mm]



Cabinet (R) assembly Width (W) 1,250 x Depth (D) 1,230 x Height (H) 800 [mm]

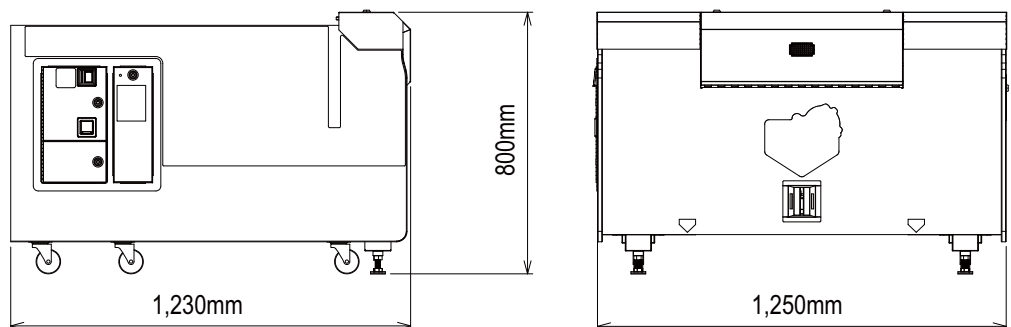

1

2

3

4

5

6

7

8A

8B

9

10

11

12

Specifications

Test Mode

Troubleshooting

2. Specifications

Side tower assembly

Width (W) 480 x Depth (D) 890 x Height (H) 1,950 [mm]
(When the signboard is removed)

Width (W) 480 x Depth (D) 890 x Height (H) 1,640 [mm]

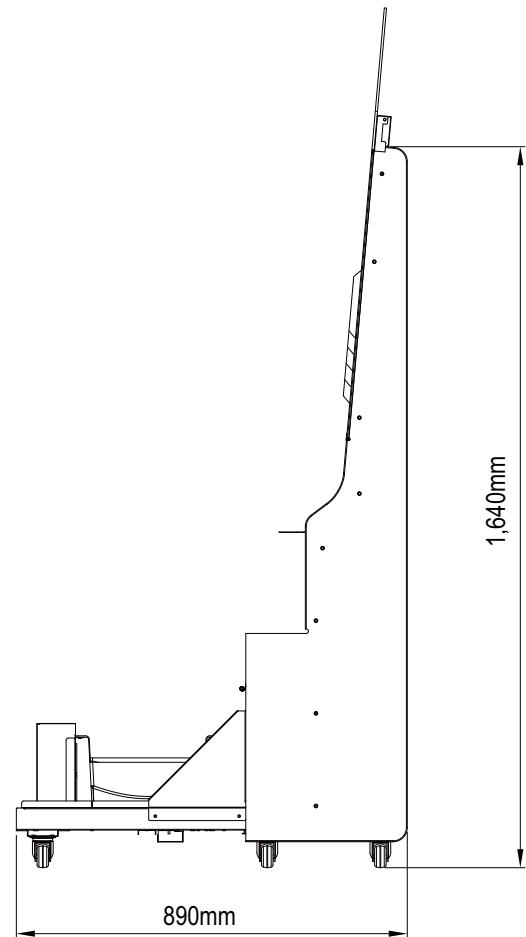
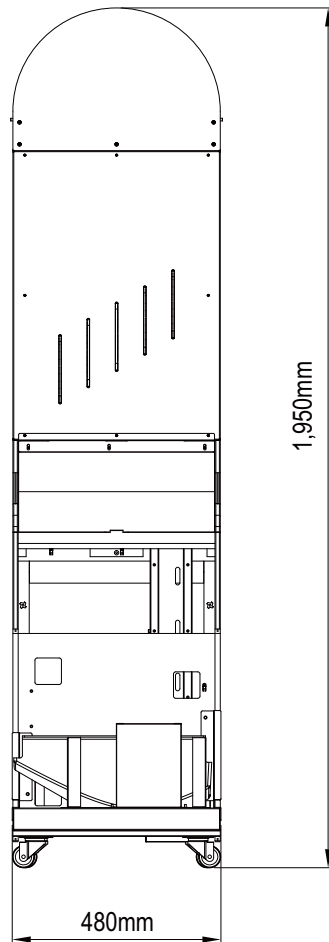

(6) Weight

1) When installed	Approx. 270 kg
2) When disassembled	
Table	Approx. 220 kg
Side tower assembly	Approx. 50 kg

3. Package Contents

The following items are included when this machine is shipped.

(1) Side tower cabinet	Width (W) 550 x Depth (D) 950 x Height (H) 1,780 [mm] Weight 60 kg
(2) Cabinet (L) assembly	Width (W) 1,290x Depth (D) 1,250 x Height (H) 840 [mm] Weight 102 kg
(3) Cabinet (R) assembly	Width (W) 1,290x Depth (D) 1,250x Height (H) 840[mm] Weight 89 kg
(4) Table top assembly	Width (W) 2,120 x Depth (D) 1,250 x Height (H) 140 [mm] Weight 77 kg
(5) Center guard	Width (W) 1,350x Depth (D) 600 x Height (H) 80 [mm] Weight 7 kg
(6) Side net	Width (W) 1,030 x Depth (D) 770 x Height (H) 220 [mm] Weight 18kg
(7) Light Assembly	Width (W) 740 x Depth (D) 460 x Height (H) 190 [mm] Weight 5 kg



- Make sure that all the items below are contained in the product package.
- If any items are missing, contact your distributor.

1

2

3

4

5

6

7

8A

8B

9

10

11

12

Package Contents

Test Mode



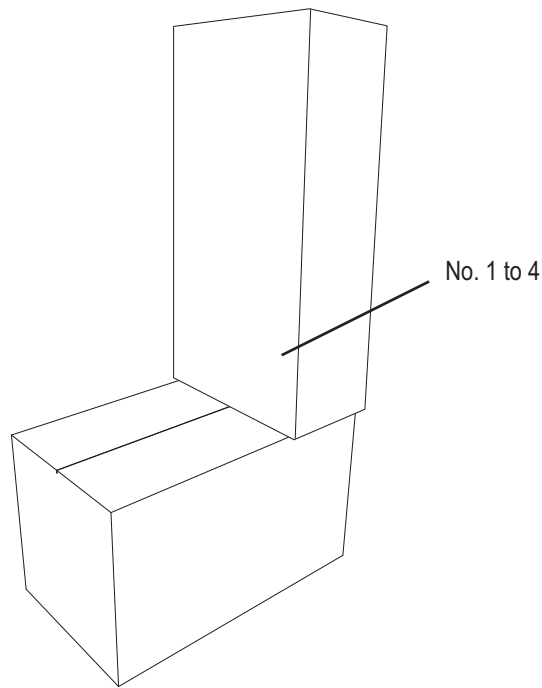

Troubleshooting

3. Package Contents

(1) Side tower cabinet

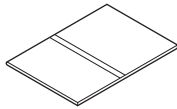





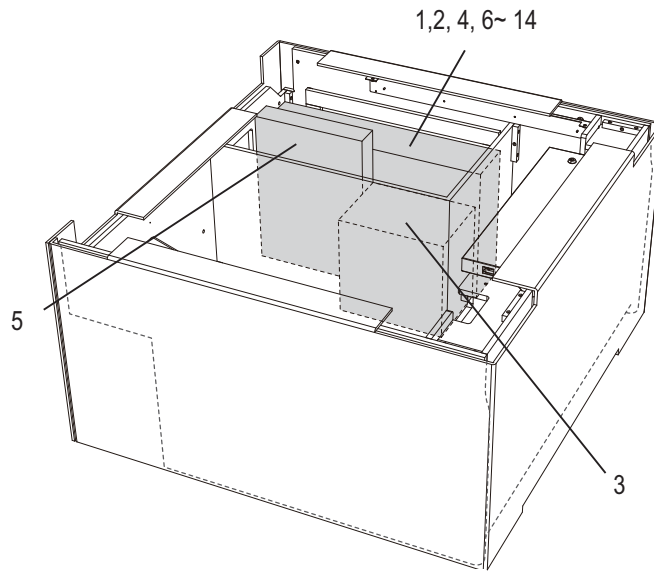

● Package contents

No.	Name	Specification		Qty.
1	Operation Manual (this manual)			1
2	Service key			2
3	Torx wrench	T25 for M5		1
4	Torx wrench	T20, for M4		1

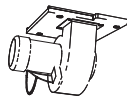
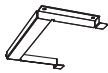
(2) Cabinet (L) assembly

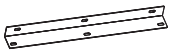

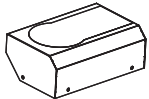
● Package contents

No.	Name	Specification	Qty.
1	Service key		2
2	Screws	See “● List of screws” on page 19.	1 set
3	Blower fan		1
4	Blower bracket		1
5	Signboard Assembly		1
6	Side tower bracket		2
7	Side wall		2
8	Corner cover	Four types: (Pink • L), (Pink • R), (Green • L), (Green • R) 	4
9	Mallet		4





1
2
3
4
5
6
7
8A
8B
9
10
11
12

Package Contents

Test Mode

Troubleshooting

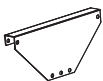

3. Package Contents

No.	Name	Specification	Qty.
10	Big puck		10
11	Mini puck	(Pink, orange, green: 50 each) 	150
12	Center guard bracket (A)		1
13	Center guard bracket (B)		1
14	Triangle bracket		1

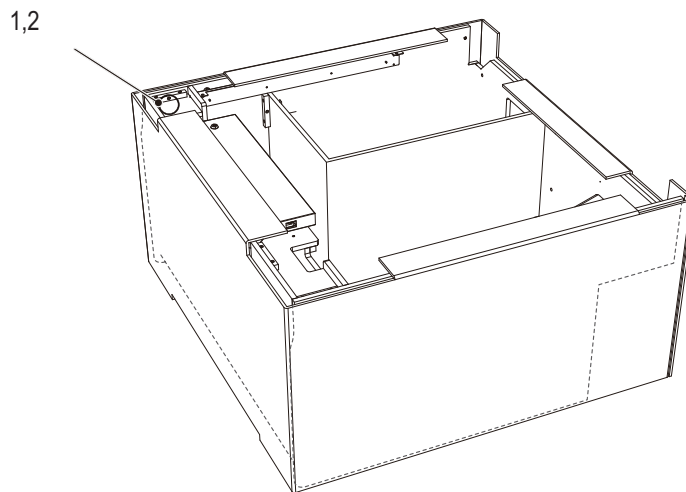
(3) Cabinet (R) assembly



● Package contents

No.	Name	Specification	Qty.
1	Service key		2
2	Coin door key		2

(4) Table top assembly

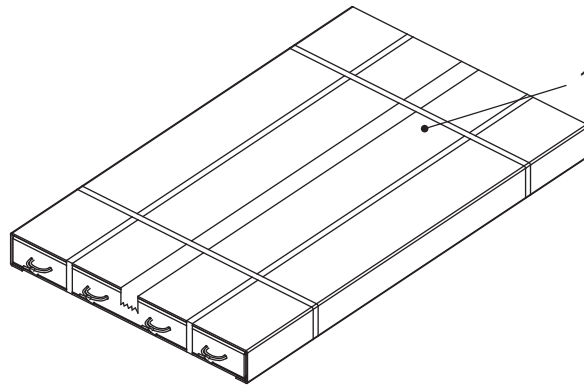

● Package contents

No.	Name	Specification	Qty.
1	Table top assembly		1

(5) Center guard

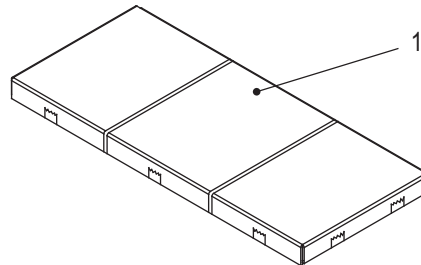

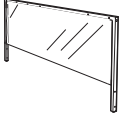

● Package contents

No.	Name	Specification	Qty.
1	Center guard unit		1

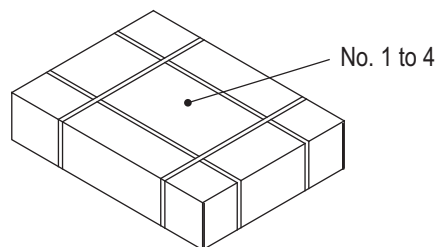
(6) Side net



● Package contents

No.	Name	Specification	Qty.
1	Net L frame (L)		1
2	Net L frame (R)		1

1

2

3

4

5

6

7

8A

8B

9

10

11



12

Package Contents

Test Mode

Troubleshooting

3. Package Contents

No.	Name	Specification	Qty.
3	Net S frame (L)		1
4	Net S frame (R)		1



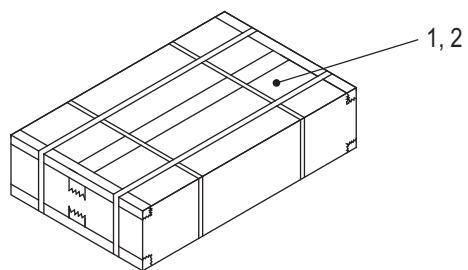



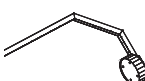
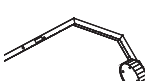





(7) Light Assembly

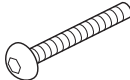
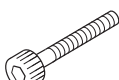

● Package contents

No.	Name	Specification	Qty.
1	Light assembly L		1
2	Light assembly R		1

List of screws (included with the cabinet (L) assembly)

No.	Name	Specification		Qty.
B1	Phillips hexagon socket head bolt (with flat and spring washers)	M8×35		9
B2	Phillips hexagon socket head bolt (with flat and spring washers)	M5×8		4
B3	Phillips hexagon socket head bolt (with flat and spring washers)	M5×15		4
B4	Phillips hexagon socket head bolt (with flat and spring washers)	M6×16		8
B5	Button head bolt	M5×35		7
B6	Button head bolt	M6×16		22
B7	Button head bolt (BLACK)	M6×16		12
B8	Button head bolt	M6×40		30
B9	Flange socket bolt	M5×30		4
B10	Torx bolt	M4×8		2
B11	Spring washer	M5		4
B12	Countersunk cap bolt	M4×8		4
B13	Flat washer	ø30 for M9		9
B14	Pan head bolt (with flat and spring washers)	M4×8		3

1

2

3

4

5

6

7

8A

8B

9

10

11





12

Package Contents

Test Mode

Troubleshooting

3. Package Contents

No.	Name	Specification	Qty.
B15	Cap nut	M5 	7
B16	Flat washer	M6 	42
B17	Flat washer	M5 	18
B18	Flat washer	ø16 for M6 	4

1

2

3

4

5

6

7

8A

8B

9

10

11

12

Package Contents

Test Mode

Troubleshooting

4. Overall Structure (Part Names)

■ Overall

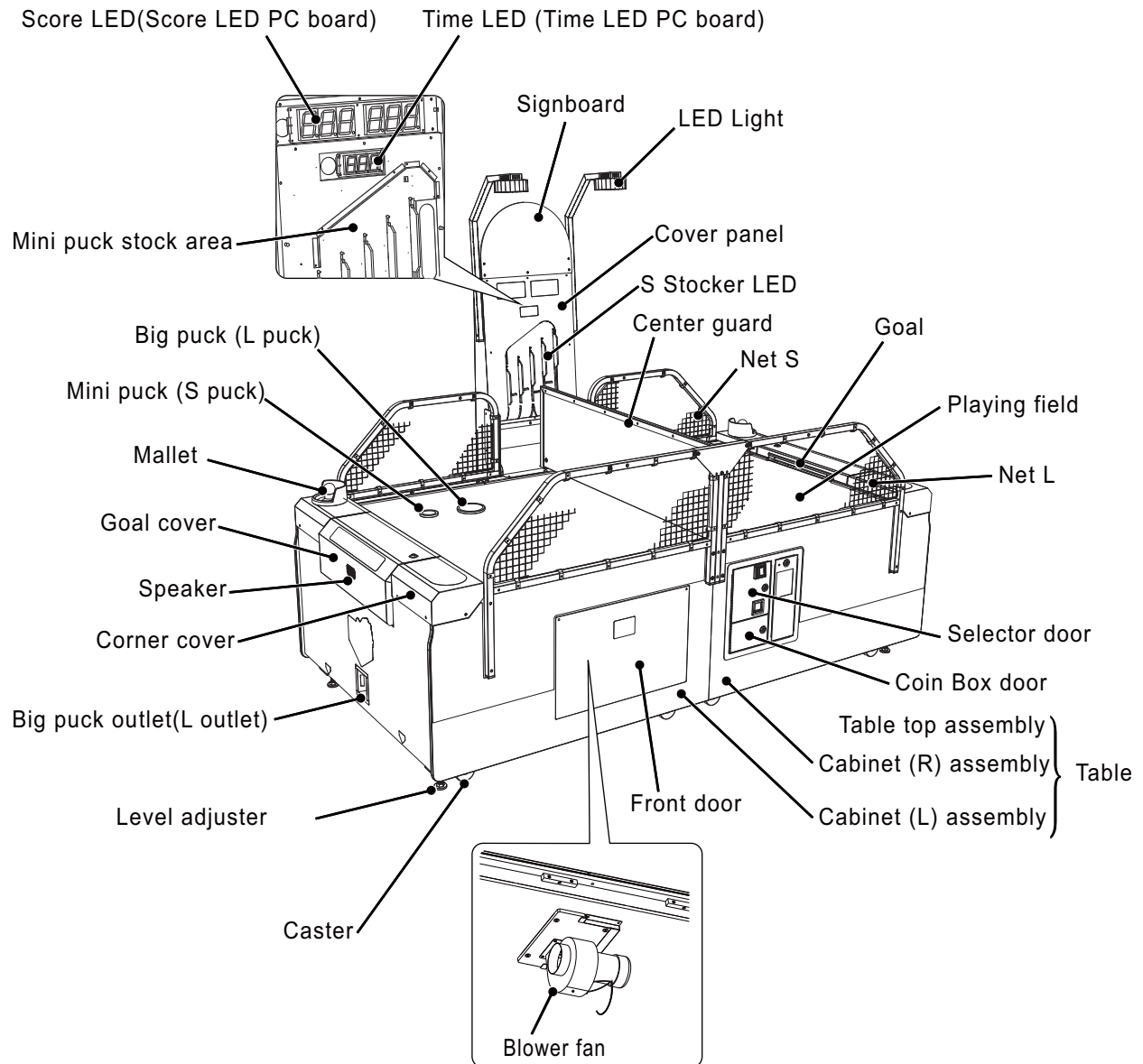

Overall (back and interior)

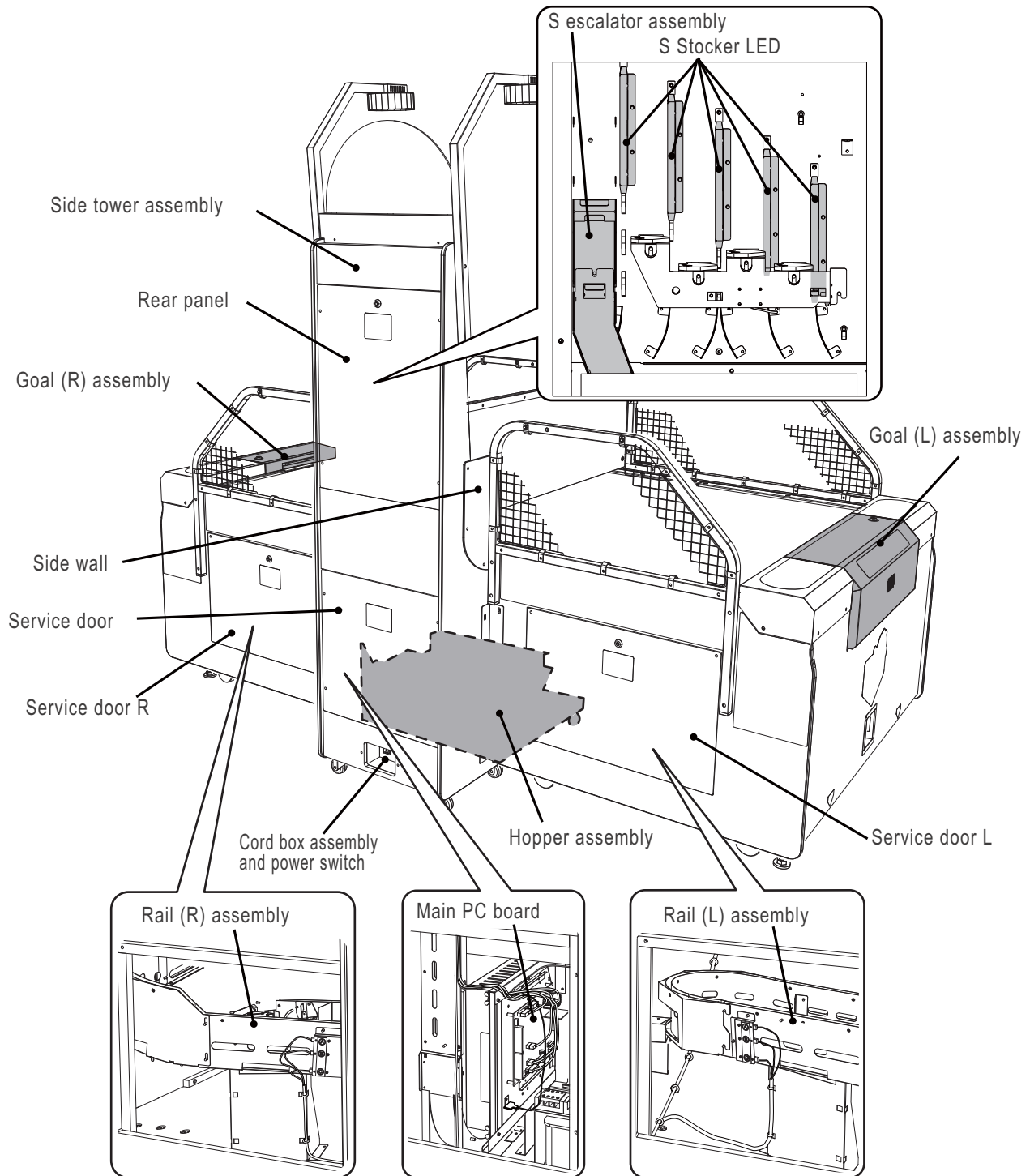

1

2

3

4

5

6

7

8A

8B

9

10

11

12

Overall Structure (Part Names)

Test Mode

Troubleshooting

5. Installation

WARNING

- Install the machine according to the instructions in this Operation Manual. Failure to follow these instructions may result in a fire, electric shock, injury or malfunction. (See “8A Installation and Assembly” on page 65.)
- Install the machine securely by using the level adjusters. Unstable machine installation may result in an accident or injury. (See “8A-2-2 Level Adjuster Adjustment” on page 77.)
- Fully insert the power cord plug into the outlet. Poor contact may generate heat and result in a fire or burns.
- Be sure to install the ground wire. Failure to install the ground wire may result in electric shock in the event of electrical leakage. (See “8A-3 Connecting the Power Cord and Ground” on page 86.)

5-1 Installation Conditions

5-1-1 Installation Locations to Avoid

WARNING

- The machine is designed for indoor use. Do not install the machine outdoors. Also, never install the machine in the following locations.
 - A location exposed to direct sunlight
 - A location exposed to rain or water leaks
 - A damp location
 - A dusty location
 - A location close to heaters
 - A hot location
 - An extremely cold location
 - A location exposed to condensation caused by temperature differences
 - A location that obstructs an emergency exit or fire extinguishing equipment
 - An unstable location or a location exposed to vibration

5-1-2 Play Zone for the Installed Machine

CAUTION

- Create a play zone around the machine so that players do not bump into bystanders or passersby.

NOTICE

- Leave a space of 100 cm or more between the machine and the wall or other machines so that parts can be removed when performing service work.
- A ceiling height of 2 m 10 cm or more is required.

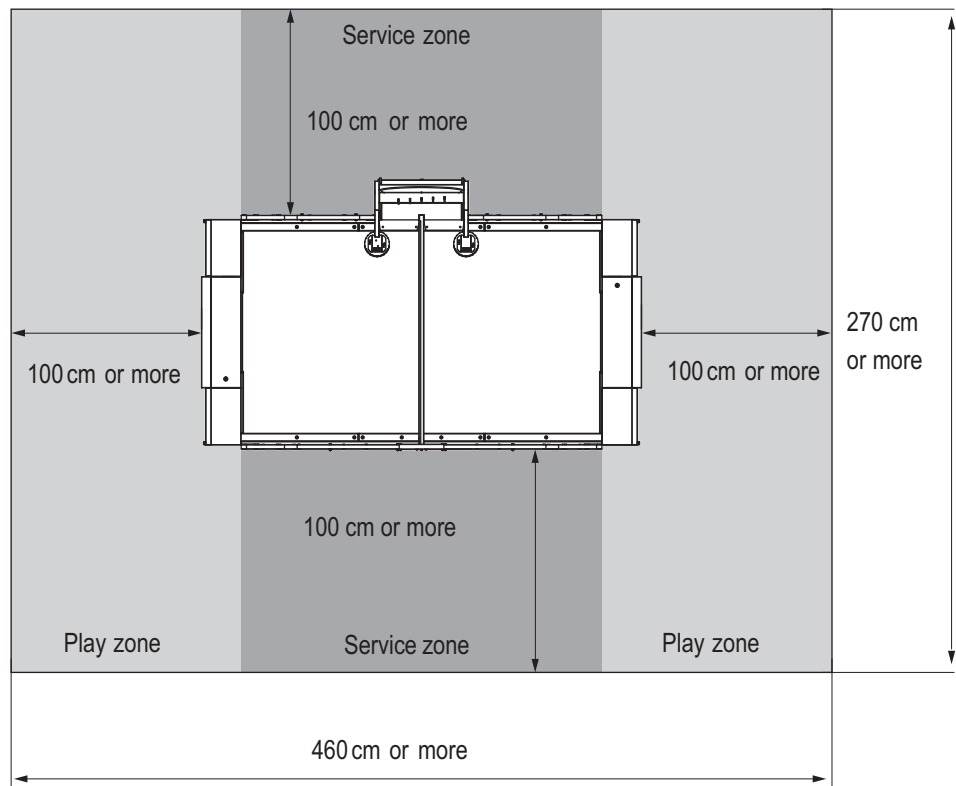

1

2

3

4

5

6

7

8A

8B

9

10

11

12

Installation Conditions

Test Mode

Troubleshooting

5-2 Required Dimensions for the Delivery Route (Such as Doors and Corridors)

Entranceways and the delivery route must be larger than the dimensions noted below

- **Table**

Width (W) 2,450 x Depth (D) 1,300 x Height (H) 1,150 [mm]

Weight 258 kg

In addition, the table can be disassembled as follows. (Condition when shipped from the factory)

- **Table top assembly**

Width (W) 2,080 x Depth (D) 1,220 x Height (H) 90 [mm]

Weight 57 kg

- **Cabinet (L) assembly (without net L and S)**

Width (W) 1,250 x Depth (D) 1,230 x Height (H) 800 [mm]

Weight 79 kg

- **Cabinet (R) assembly (without net L and S)**

Width (W) 1,250 x Depth (D) 1,230 x Height (H) 800 [mm]

Weight 85 kg

- **Side tower assembly**

Width (W) 480 x Depth (D) 890 x Height (H) 1,950 [mm]

Weight 52 kg

6. Moving and transporting

WARNING

Do not leave the machine on a slope. It may fall over or result in an accident.

6-1 Moving (On the Same Floor)



NOTICE

Move the machine carefully to avoid damaging it.

The plastic parts are weak. Do not exert strong force on these areas.

When moving the machine, be sure to raise the level adjusters to their highest level.

Be sure to turn off the power switch before starting work.

Handle the power cord carefully.

1

2

3

4

5

6

7

8A

8B

9

10

11

12

Required Dimensions for the Delivery Route (Such as Doors and Corridors) / Moving (On the Same Floor)

Test Mode

Troubleshooting

6-2 Transporting

6-2-1 Transporting Manually (Such as Carrying on Stairs)

WARNING

Before transporting the machine manually, be sure to disassemble it into the table and side tower assembly, and disassemble the hopper assembly from the side tower assembly for easier carrying. Overburdening yourself by attempting to transport the fully assembled machine may result in an accident or injury.

Disassemble the table in accordance with the delivery route. (See “5-2 Required Dimensions for the Delivery Route (Such as Doors and Corridors)” on page 26.)

When transporting the machine manually, be sure to use the following number of people. Overburdening yourself may result in an accident or injury.

- Table (258 kg): 10 people or more
- Side tower cabinet (excluding the hopper assembly: 50 kg): 2 people or more

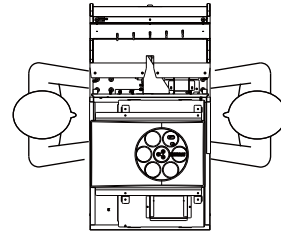
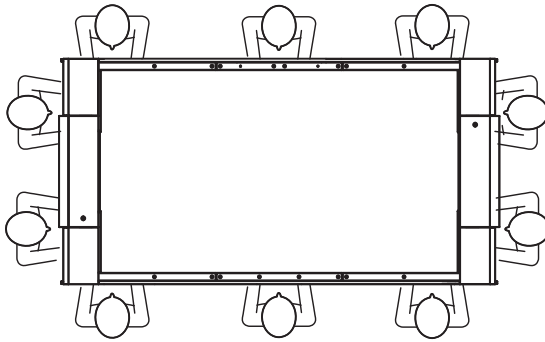

! WARNING

When transporting the machine manually, be sure to use the following number of people. Overburdening yourself may result in an accident or injury.

[When the table is disassembled]

- Table top assembly (57 kg): 4 people or more
- Cabinet (L) assembly (79 kg): 4 people or more
- Cabinet (R) assembly (85 kg): 4 people or more

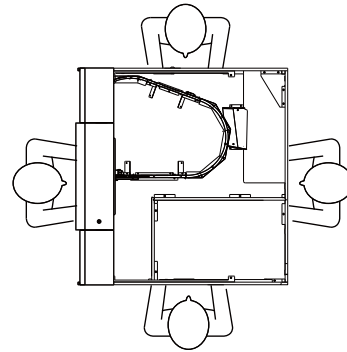
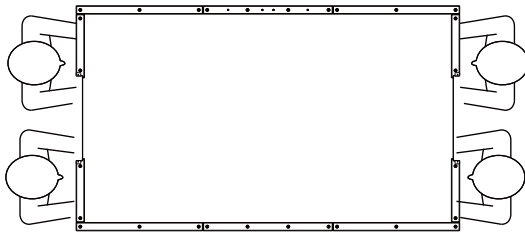

Do not subject the machine to impact while lowering it.

1

2

3

4

5

6

7

8A

8B

9

10

11

12

Transporting

Test Mode

Troubleshooting

6-2-2 Loading and Unloading to and from a Vehicle

WARNING

When loading this machine to a vehicle, always be sure to divide side tower assy, cabinet (L) • (R) assy, table top assy, side guard and side net for easy to carry status. (Please see "8A Installation and Assembly" on page 65.)

In case of loading the machine to a vehicle without dividing the parts, it may cause unexpected accident.

When moving, transporting and loading/ unloading the machine by a forklift, please be to insert the fork into the specified positions. Please be careful with the balance. In case of putting a fork in a different position, the balance will collapse and it will cause an unexpected accident.

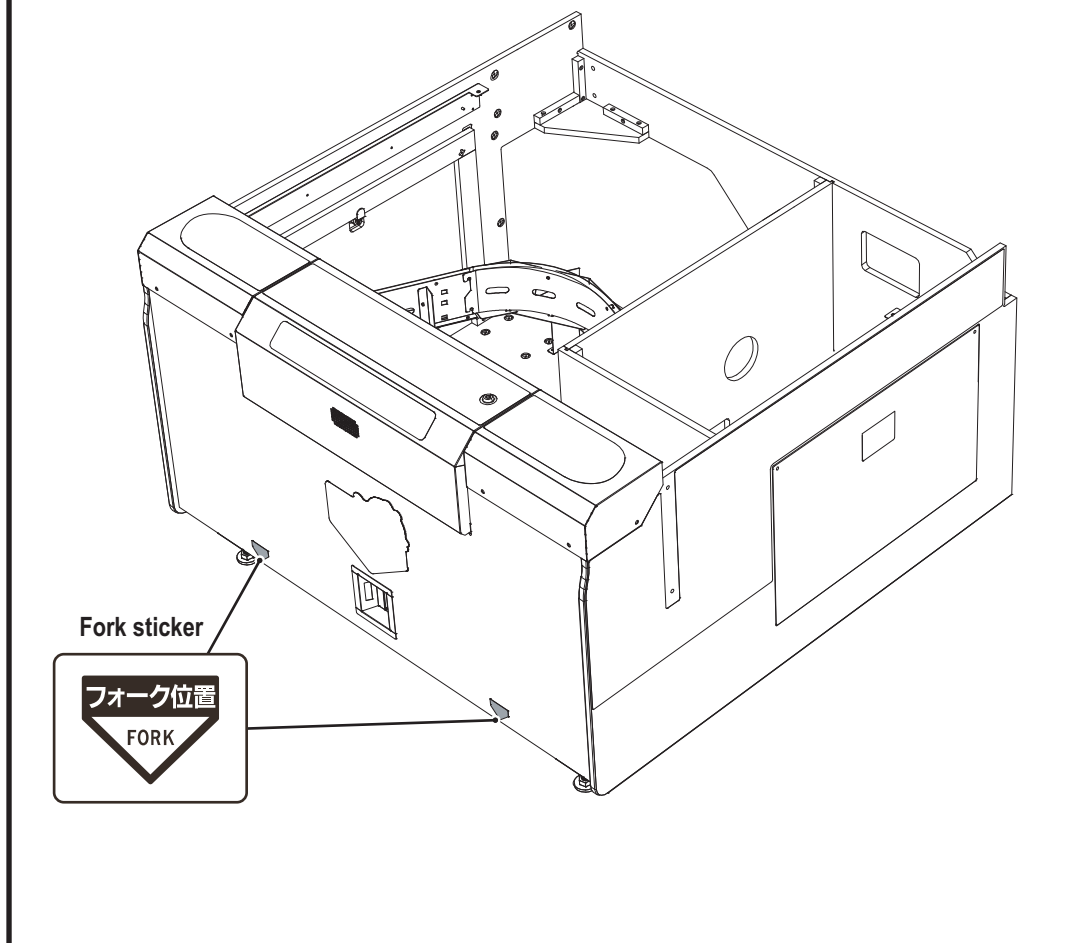

Do not subject the machine to impact while lowering it.

6-2-3 Transporting on a Vehicle

! WARNING

When transporting the machine on a vehicle, secure the machine firmly so that it does not move during vehicle transport. Failure to secure the machine may result in an accident.

NOTICE

Do not subject the machine to impact while lowering it.

Remove any pucks from inside the side tower cabinet when transporting the machine.

When securing the machine with a rope, observe the following.

- Be sure to secure the machine with the rope or belt in the position shown in the figure below.
- Place blankets or other shock absorbing material between the machine and the rope or belt to protect the machine surfaces.

Place Styrofoam or other shock absorbing material between the machine and the truck bed and any other equipment or items to protect the machine surfaces.

When transporting the machine in rainy weather, use a vehicle with a cargo cover, a container truck, or similar vehicle to protect the machine from direct exposure to rain.

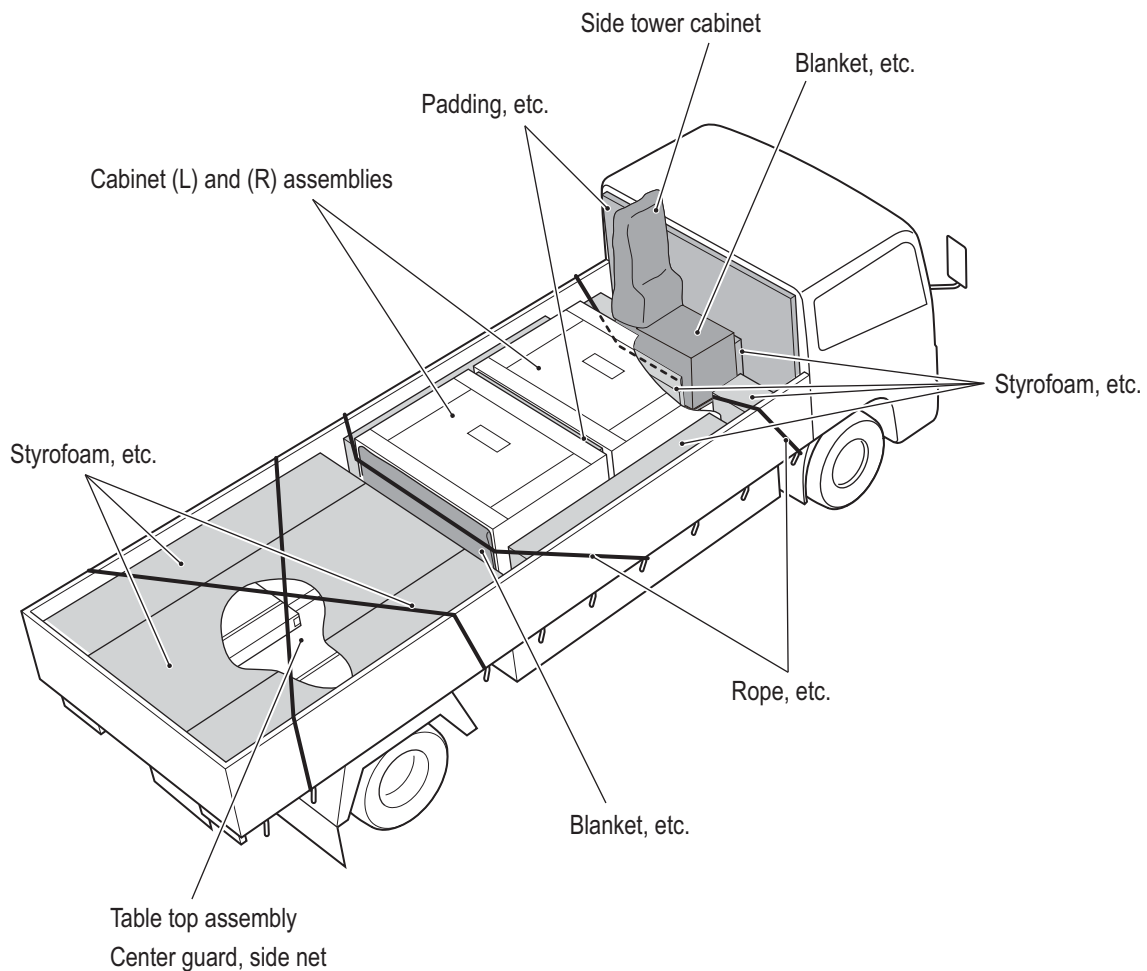

1

2

3

4

5

6

7

8A

8B

9

10

11

12

Transporting

Test Mode

Troubleshooting

7. Operation

WARNING

Should an abnormality occur, turn off the power switch immediately to stop operations. Then, be sure to disconnect the power cord plug from the outlet. Operating the machine while the abnormality persists may result in a fire or accident.

If you do not clean the inside of this machine for a long period of time, dust may cause a fire or malfunction. After purchasing, clean the inside regularly.

Dust accumulating on the power cord plug may result in a fire. Inspect the plug regularly and remove any dust.

Fully insert the power cord plug into the outlet. Poor contact may generate heat and result in a fire or burns.

Before operating the machine, be sure to check that installation has been performed according to the instructions and specified procedures (See “5 Installation” on page 24.) in this Operation Manual. Omitting these inspections may result in an accident.

The warning labels attached to the machine contain important information for ensuring safety. Be sure to observe the following. (For the warning label locations, see “1-4 Machine Warning Labels” on page 3.)

- To ensure that the warning labels attached to the machine are always clearly visible, install the machine in an appropriate location with ample illumination and keep the labels clean at all times. Make sure that the labels are not hidden by other machines or objects.
- Do not remove or alter the warning labels.
- If a warning label becomes excessively dirty or damaged, replace it with a new one.

To order warning labels, contact your distributor.

To ensure safe use of the machine, be sure to perform the pre-operation inspection (See “7-4 Pre-operation Inspection” on page 35.) and service (See “8B Service” on page 89) described in this Operation Manual. Omitting these inspections or service may result in an accident.



Due to the nature of this product, the mallets and pucks may get stolen. If possible, install and operate the machine in a location where it can be observed by venue staff.

Mallets and pucks may be left on the playing field after game play has finished. In these cases, return the mallets to the mallet holders, and place the pucks inside the goals.

Caution players and bystanders not to place drinks or other items on the playing field. In the event that drinks are spilled onto the machine by accident, wipe away any liquid immediately.

7-1 People Who Should Avoid Playing

WARNING

To ensure the safety of players, be careful not to let the following types of people play. Otherwise, this may result in an accident.

- People who drink alcohol
- People who are injured or ill
- People who are pregnant
- People who disregard the warning labels attached to the machine

7-2 Safety Precautions for Playing

WARNING

If you discover anyone behaving as follows, be sure to caution them. Otherwise, this may result in an accident.

- A person other than the player in the play zone
- Make sure that players do not perform the following actions, as this may cause pucks to fly out of the machine and strike people or otherwise result in injury or an accident.
- Striking pucks with more power than is necessary
 - Striking pucks while off-balance, leaning in or an otherwise unstable body posture
 - Using items other than the supplied mallets and pucks

CAUTION

Make sure that players do not perform the following actions, as this may result in injury or an accident.

- Holding mallets by the circumference.
- Placing hands not holding a mallet in the playing field.
- Placing hands inside the goal holes.

Accessories such as necklaces and bracelets, neckties, wristwatches, small items in breast pockets and other loose items may fall and enter the goals as a result of vigorous movements during game play. Instruct players to remove these items before playing in order to prevent damage or an accident. Otherwise, this may result in an accident.

1

2

3

4

5

6

7

8A

8B

9

10

11

12

People Who Should Avoid Playing / Safety Precautions for Playing

Test Mode

Troubleshooting

7-3 Important Parts for Ensuring Player and Bystander Safety

WARNING

This machine includes important parts used to ensure the safety of players and bystanders. Operating the machine while these “important parts for ensuring player and bystander safety” are broken, damaged or deteriorated, or with defective installation may result in an injury to the players or bystanders. If you discover an abnormality, replace the affected part immediately. To order parts, contact your distributor.

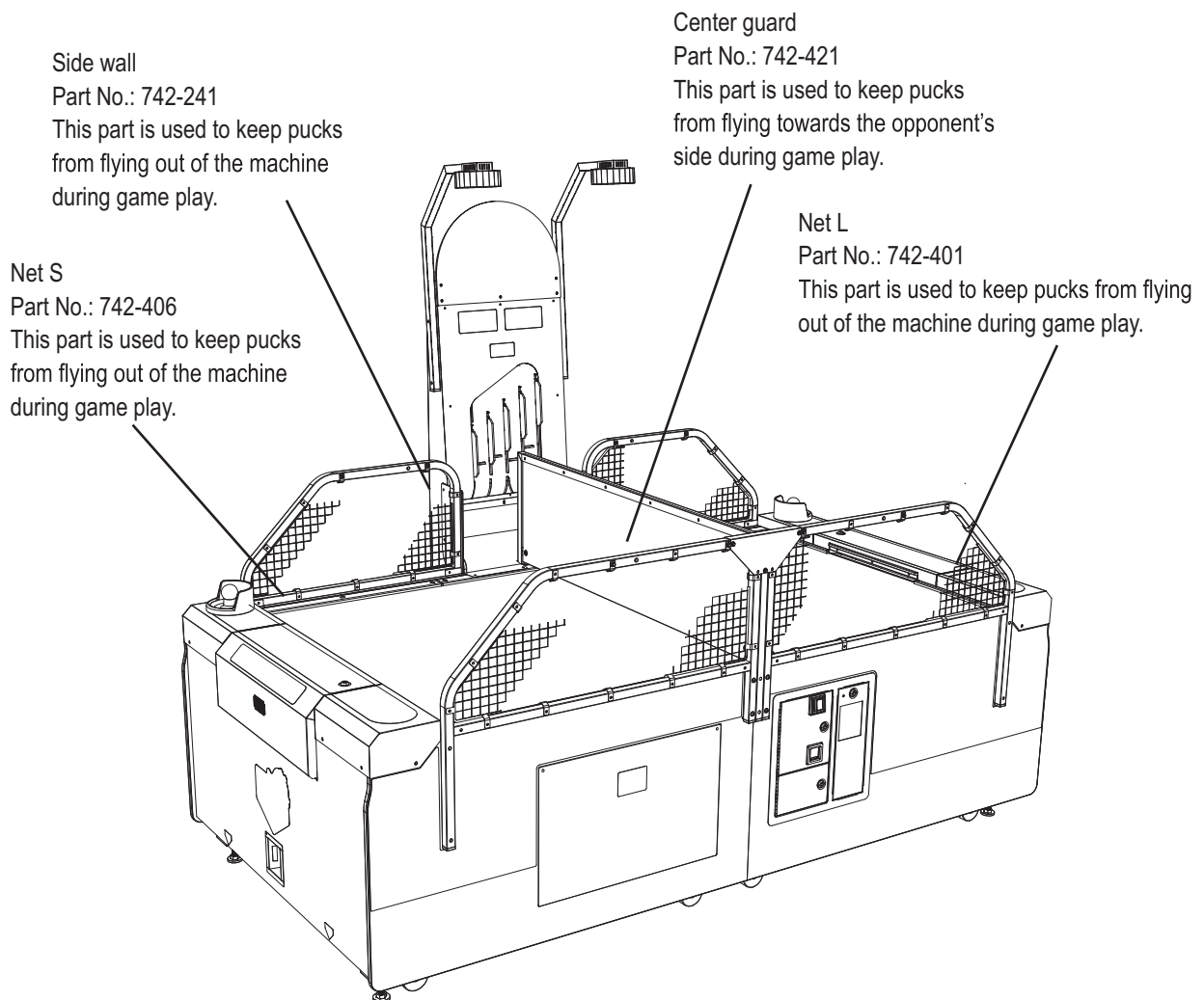

7-4 Pre-operation Inspection

Check the items below before starting machine operations. If there is an abnormality, resolve it by referring to "8B-3 Troubleshooting" on page 130.

7-4-1 Safety Inspection Items (Before Power On)



WARNING

Before operating the machine, check the following locations. This is required to prevent accidents or injury.

- (1) Are all warning labels in place? (See "1-4 Machine Warning Labels" on page 3.)
- (2) Are all warning labels legible? (See "1-4 Machine Warning Labels" on page 3.)
- (3) Are all level adjusters adjusted properly? (See "8A-2-2 Level Adjuster Adjustment" on page 77.)
- (4) Is the specified play zone provided? (See "5-1-2 Play Zone for the Installed Machine" on page 25.)
- (5) Is the power cord laid out safely so that it will not cause players or other customers to trip over it?
- (6) Is the power cord securely connected to the outlet and the power supply input of the machine? (See "8A-3 Connecting the Power Cord and Ground" on page 86.)
- (7) Is the power cord plug free from dust?
- (8) Are the mallets damaged?
- (9) Are the mallet grips loose?
- (10) Are the net S, net L, center guard or side guards damaged? (See "7-3 Important Parts for Ensuring Player and Bystander Safety" on page 34.)
- (11) Are the goal covers or corner covers damaged?

Inspect the following items after turning on the power switch. If you discover an abnormality, turn off the power switch immediately to stop operations. Then, disconnect the power cord plug from the outlet and contact your distributor.

- (12) Is any part of the power cord or plug abnormally hot?
- (13) Does touching the machine give a tingling electric shock?
- (14) Is there a burning smell, abnormal noise or vibration?
- (15) Is there any other abnormality or malfunction?

1

2

3

4

5

6

7

8A

8B

9

10

11

12

Important Parts for Ensuring Player and Bystander Safety / Pre-operation Inspection

Test Mode

Troubleshooting

7-4-2 Function Inspection Items (After Power On)

- (1) Check the lights. (Do the score LED, time LED, S stocker LED, goal LED and L outlet LED light up?)
(See "7-8-2 Score LED, Time LED and S stocker LED, goal LED and outlet LED Test" on page 42.)
- (2) Check the switch inputs.
(See "7-8-3 Switch Input Test" on page 43.)
- (3) Check the blower fan.
(See "7-8-4 Blower Fan ON/OFF Test and Sensor Check" on page 45.)
- (4) Check each solenoid.
(See "7-8-5 Solenoid ON/OFF Test and Sensor Check" on page 46.)
- (5) Check the S hopper motor operation.
(See "7-8-6 S Hopper Motor ON/OFF Test and Sensor Check" on page 47.)
- (6) Check the audio. (Is sound produced by each speaker?)
(See "7-8-7 Sound Test" on page 48.)
- (7) Check the mini pucks. (Are there 16 mini pucks in the mini puck stock area?)
(See "7-8-6 S Hopper Motor ON/OFF Test and Sensor Check" on page 47.)

7-5 Opening and Closing Doors

7-5-1 Opening and Closing the Selector Door

- 1** Use the supplied selector door key to open the selector door.

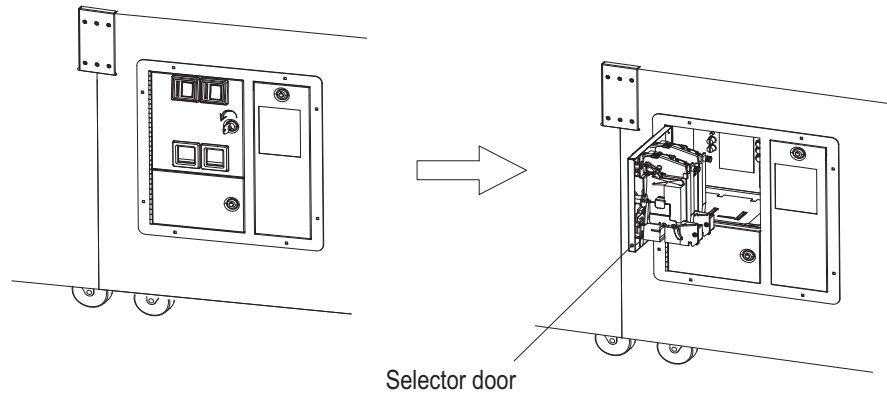

- 2** To close the door, perform the procedure in reverse.

7-5-2 Opening and Closing the Coin Box Door

- 1** Use the supplied cash box key to open the coin box door.

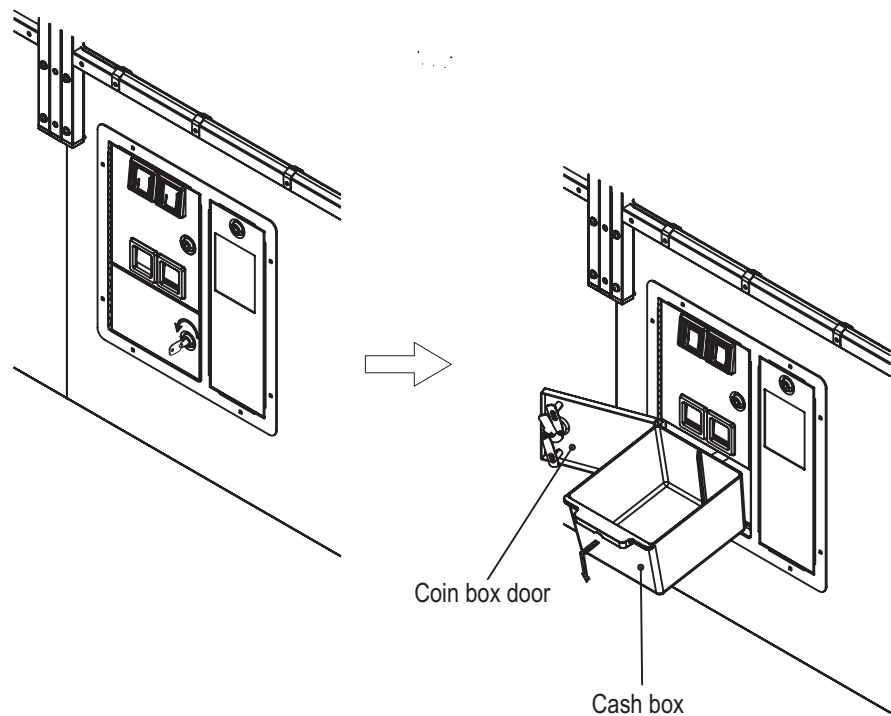

- 2** To close the door, perform the procedure in reverse.

1

2

3

4

5

6

7

8A

8B

9

10

11

12

Opening and Closing Doors

Test Mode

Troubleshooting

7-5-3 Opening and Closing the Goal (L) and (R) Assemblies

The description below explains how to open and close the (L) side. Follow the same procedure to open and close the (R) side.

- 1** Use the supplied service key to unlock the lock on the right side of the goal (L) assembly, and then open the goal (L) assembly.

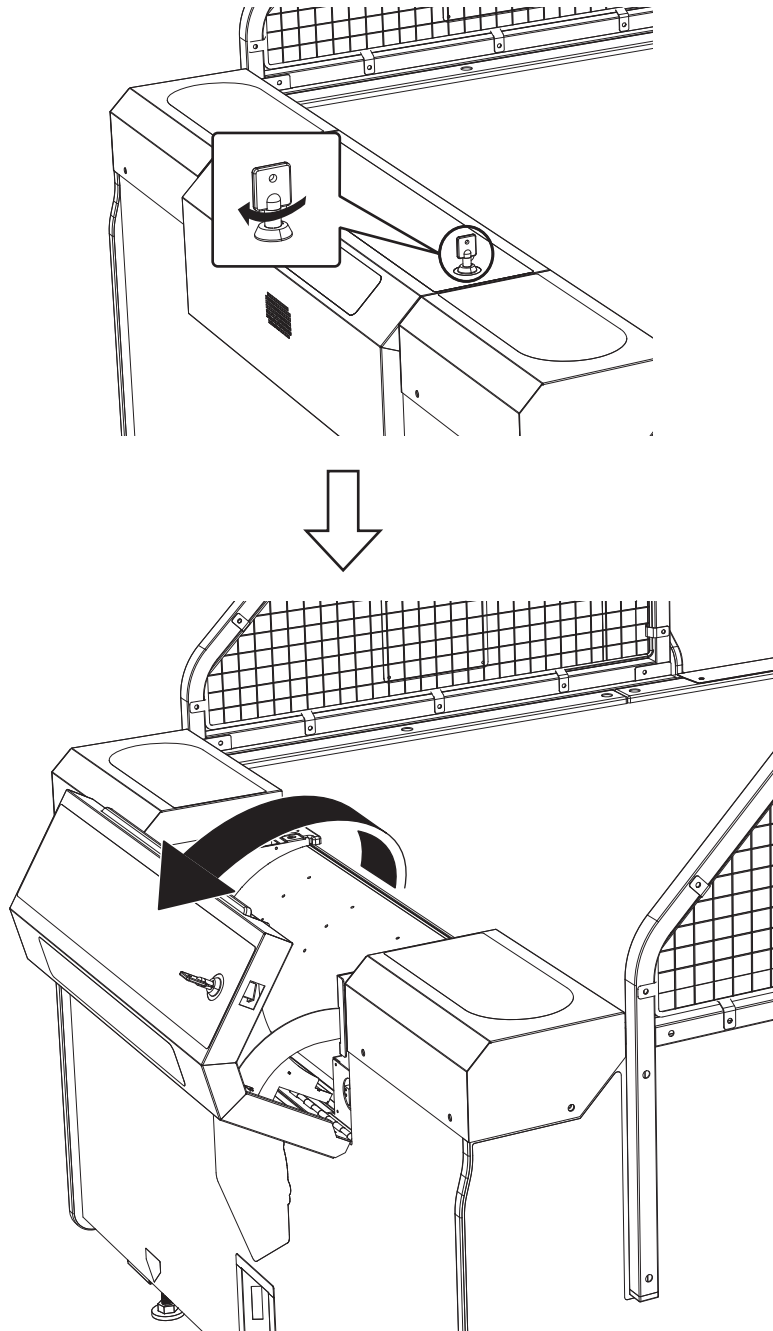

- 2** To close the door, perform the procedure in reverse.

7-6 Explanation of the Power Switch and Adjustment Switches

7-6-1 Turning the Power Switch On

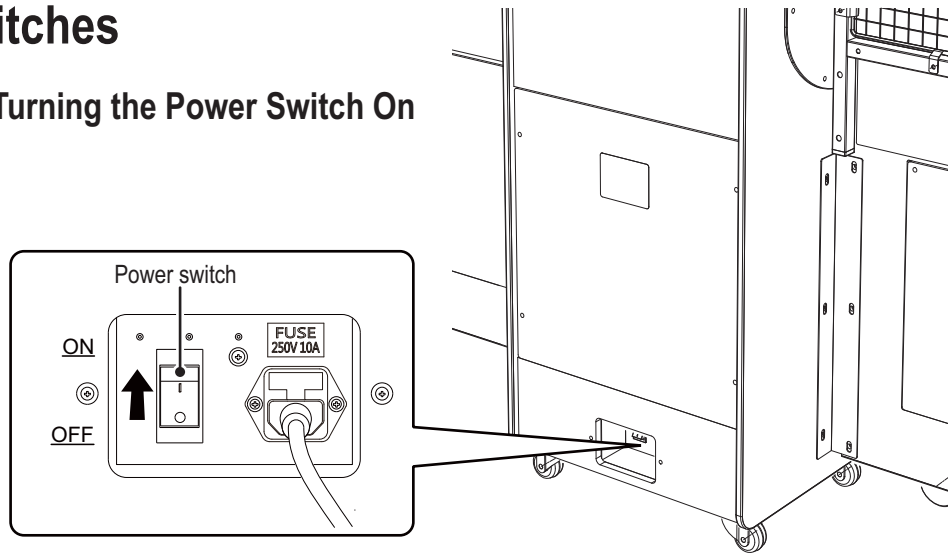

- After finishing the installation work, turn on the power switch.
- When turning the power switch on and off, wait 30 seconds or more between operations. Do not turn the power switch on and off needlessly. It may corrupt the contents of the backup memory.

7-6-2 Adjustment Switches

The adjustment switches are located inside the selector door.

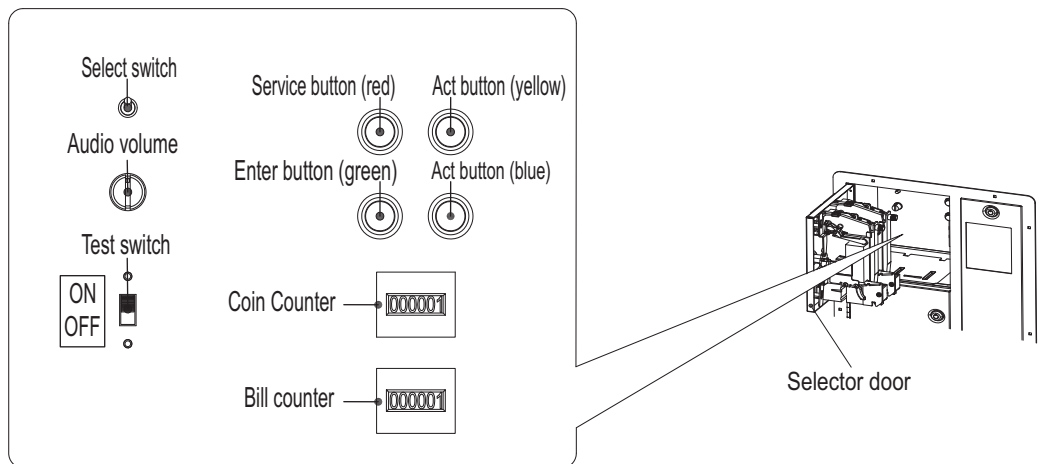

Select switch

In Test mode, flip this switch up or down to select an item or setting (numerical value).

Audio volume

This adjusts the speaker volume.
Turn counter-clockwise to decrease the volume.
Turn clockwise to increase the volume.

Test switch

Set this switch to ON to enter Test mode. This is used to test each part of the machine, such as the switch input test, in the Test mode. (See "7-8 Test Mode" on page 41.)

Service button (red)

Press this button to increase the credit count without operating the coin counter.

Enter button (green)

After selecting an item or setting (numerical value) with the Select switch, press this button to enter or execute the selection.

Action button (yellow/blue)

In Test mode, these buttons are used at the time of operation

7-7 Playing the Game

This machine is an air hockey game where players use mallets to hit pucks supplied automatically during the set time into the opponent's goal to score points.

- (1) The start sound is output, and then a big puck is supplied to the Big puck outlet. At the same time, the time LED blinks.
- (2) Players use the mallets to hit the big puck towards the opponent's goal.
- (3) When the big puck enters a goal, 10 points are added to the score LED of the scoring player, and the goal sound (ascending musical scale) is output three times from the speaker on the side where the goal was scored.
- (4) A big puck is supplied to the Big puck outlet on the side where the goal was scored.
- (5) 16 mini pucks are supplied to the game all at once at random times during game play and toward the end of game play.
- (6) When a mini puck enters a goal, 3 points are added to the score LED of the scoring player and the goal sound (ascending musical scale) is output one time.
- (7) The countdown sound is output starting from 10 seconds before the game ends. When the end whistle is output, the game ends and subsequent goals are not added to the score.
*The number of mini puck supply times varies according to "7-9-4 Play time", "7-9-5 Random mini puck time" and "7-9-6 the Last mini puck time".

7-7-1 Starting the Game and Game End

- (1) Insert a number of coins equal to the set game cost into the coin slot.
- (2) When the set time is exceeded, the game ends.
The set time may be extended slightly depending on the number of mini puck supply times.
When "Game Start SE" music plays, the game starts.

7-8 Test Mode

The machine displays the test contents on the cover panel that displays the score and timer.

7-8-1 Test Item Selection Mode

- 1** Use the supplied service key to open the selector door and set the Test switch to ON (slide the switch upward) to enter the Test Item Selection Mode. (See "7-6-2 Adjustment Switches" on page 39.)
- 2** Flip the Select switch up and down to select the item.
- 3** Perform the test for each item.
- 4** After finishing all the tests, set the Test switch to OFF.



- Before setting the Test switch to OFF, make sure that there are 16 mini pucks in the mini puck stock area .

Item order	Item name (Display in Test Item Selection Mode)	Item	Reference page
1		Score LED, Time LED and S stocker LED, Goal LED and L outlet LED Test	Page 42
2		Switch Input Test	Page 43
3		Blower Fan ON/OFF Test and Sensor Check	Page 45
4		Solenoid ON/OFF Test and Sensor Check	Page 46
5		S Hopper Motor ON/OFF Test and Sensor Check	Page 48
6		Sound Test	Page 49

1

2

3

4

5

6

7

8A

8B

9

10

11

12

Playing the Game / Test Mode

Test Mode

Troubleshooting

7-8-2 Score LED, Time LED and S stocker LED, Goal LED, and L outlet LED Test

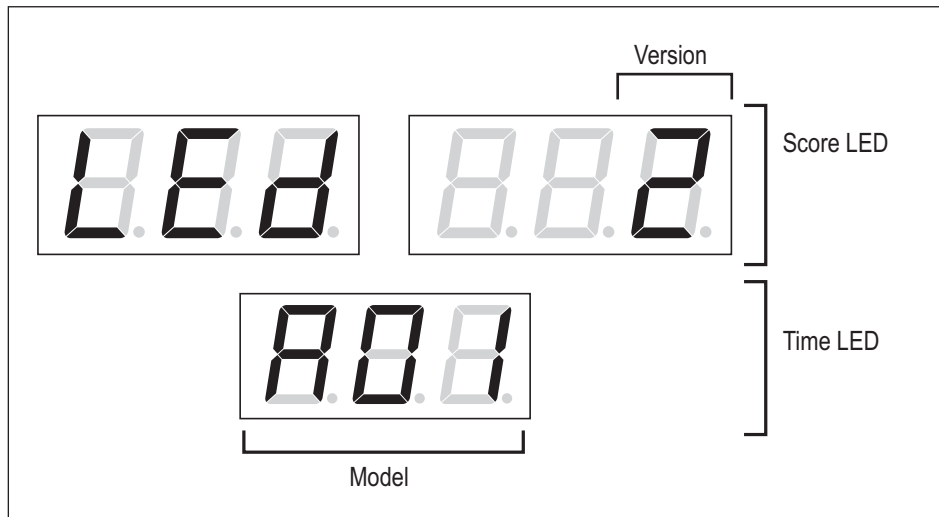

Test item selection display (Score LED, time LED, S stocker LED, Goal LED and L outlet LED test)

- 1** In this Test Item Selection Mode, “LEd” is displayed in the left side score LED. The “model (1-digit number)” is displayed in the right side score LED and “version(one alphabet character +2-digit number)” is displayed in the Time LED.

The model is indicated by a number, and has the following meaning.

Model No.	2
Model contents	Foreign

- 2** Press the Enter button (green) to start the test as follows.
- (1) Numbers are displayed in the score LED, switching repeatedly in order of 0, 1, 2, 3, 4, 5, 6, 7, 8 and 9.
 - (2) Numbers are displayed in the time LED, switching repeatedly in order of 0, 1, 2, 3, 4, 5, 6, 7, 8 and 9.
 - (3) The S stocker LED and Goal LED (illuminator assembly) switches repeatedly in the order of lighted red, green, blue, light blue, purple, yellow, white, and off.
 - (4) L outlet LED blinks continuously.
- 3** Press the Enter button (green) again to return to the Test Item Selection Mode.

7-8-3 Switch Input Test

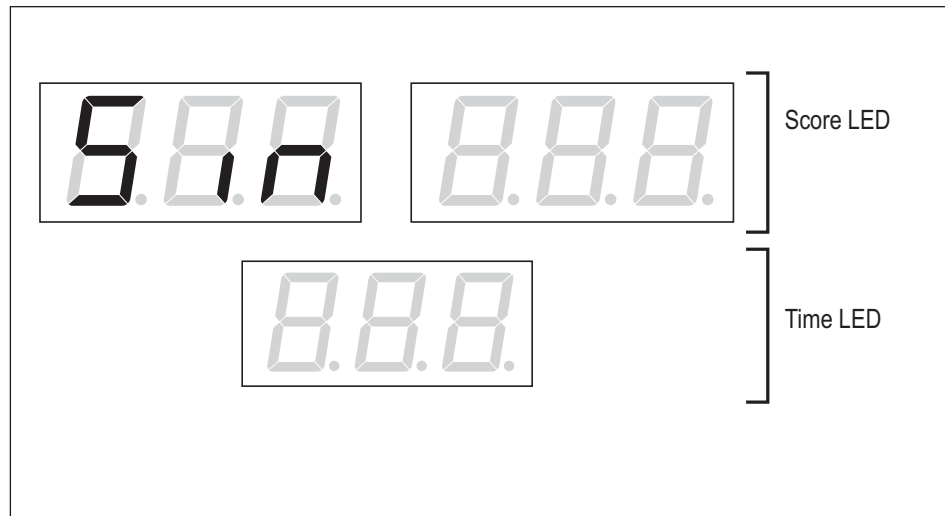

Test item selection display (Switch input test)

- 1 In this Test Item Selection Mode, "Sin" is displayed in the left side score LED.

1

2

3

4

5

6

7

8A

8B

9

10

11

12

Test Mode

Test Mode

Troubleshooting

2 Press the Enter button (green). The following test display appears.

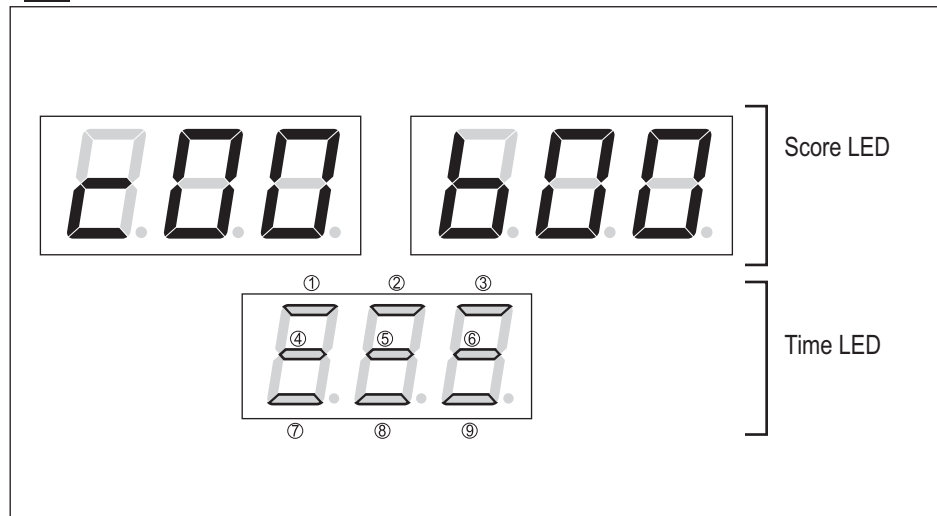

Switch input test display

- The coin switch counter value (two digits) is displayed in the left side score LED. The right side displays the bill counter input count (two digits).
 - (1) The value counts up each time there is switch input.
 - (2) The value returns to 00 after 99.
- The time LED displays the switch input states as follows.
(ON: Lighted, OFF: Off)

LED No.	Switch name
	Service button (red)
	Enter button (green)
	Selector switch UP
	Selector switch DOWN
	Act button (yellow)
	Act button (blue)
	COIN 1
	COIN 2
	Bill counter input signal

3 Press both the Service button (red) and the Enter button (green) at the same time to return to the Test Item Selection Mode.

7-8-4 Blower Fan ON/OFF Test and Sensor Check

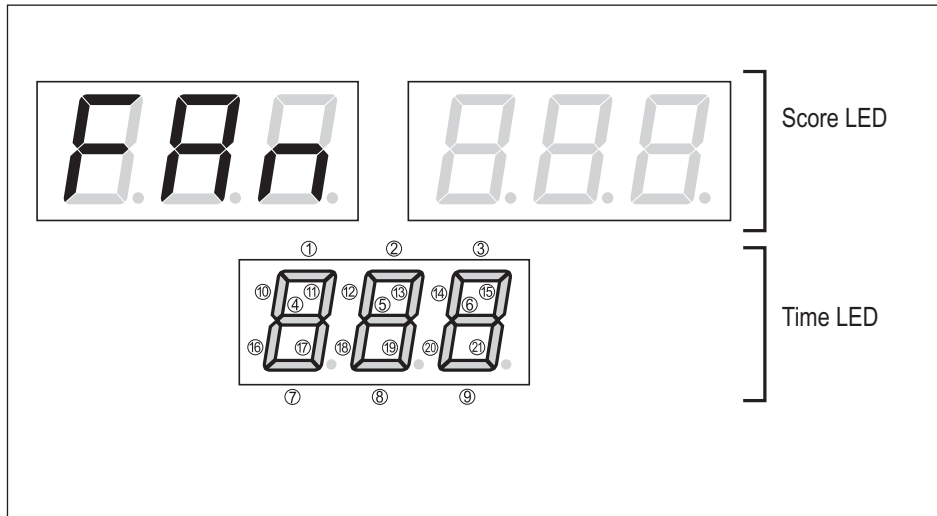

Test item selection display (Blower fan ON/OFF test)

- 1** In this Test Item Selection Mode, “FAn” is displayed in the left side score LED.
- 2** The time LED displays the sensor states as follows.
(ON: Lighted, OFF: Off)

LED No.	Sensor name	Reference page
	Rail (L) sensor (A)	Page 121
	Rail (L) sensor (B)	Page 121
	Rail (L) sensor (C)	Page 121
	L stopper(L) sensor	Page 123
①⑥	L outlet(L) sensor	Page 142
①⑦	Goal (L) sensor	Page 118
	Rail (R) sensor (A)	Page 121
	Rail (R) sensor (B)	Page 121
	Rail (R) sensor (C)	Page 121
①④	L stopper(R) sensor	Page 123
②⑩	L outlet(R) sensor	Page 142
②⑪	Goal (R) sensor	Page 118

- 3** Press the act button (yellow) to control the blower fan ON and OFF. ON:“on” is displayed in the right side score LED, OFF:Nothing is displayed in the right side score LED.

1

2

3

4

5

6

7

8A

8B

9

10

11

12

Test Mode

Test Mode

Troubleshooting

7-8-5 Solenoid ON/OFF Test and Sensor Check

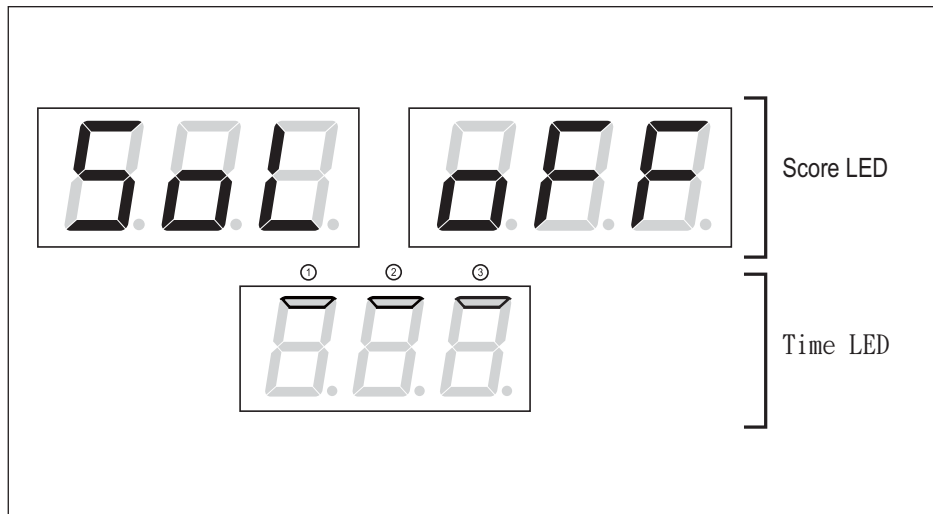

Test item selection display (Solenoid ON/OFF test)

- 1** In this Test Item Selection Mode, "SoL" is displayed in the left side score LED.
- 2** The time LED displays the sensor states as follows.
(ON: Lighted, OFF: Off)

LED No.	Sensor name	Reference page
	L Stopper (L) sensor	Page 123
	S Stopper sensor	Page 136
	L Stopper (R) sensor	Page 123

- 3** Press the act button (red) to control the L stopper solenoid L ON and OFF, and press the act button (yellow) to control the S stopper solenoids ON and OFF. Press the act button (blue) to control L stopper solenoid (R)on and off.

* Each solenoid automatically turns off 3 seconds after it is turned on.



- Before setting the Test switch to OFF, make sure that there are 16 mini pucks the mini puck stock area.

7-8-6 S Hopper Motor ON/OFF Test and Sensor Check

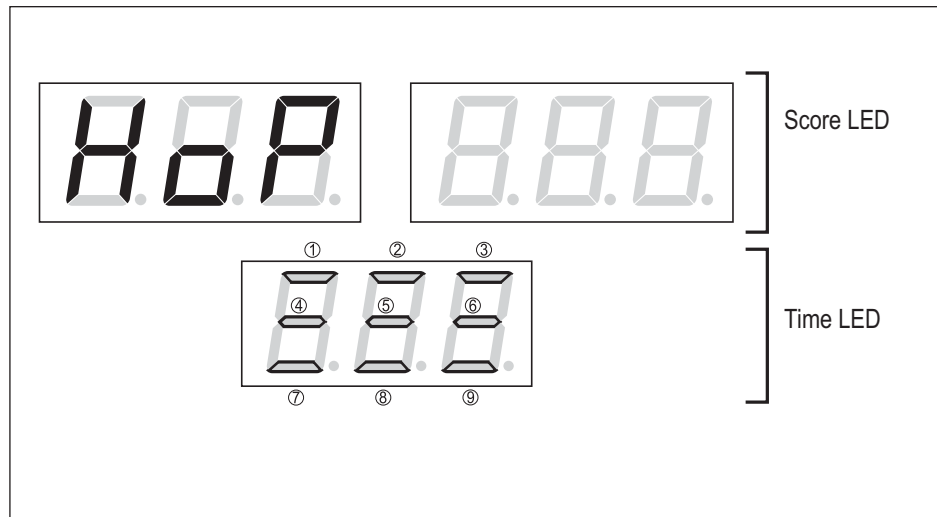

Test item selection display (S hopper motor ON/OFF test)

- 1** In this Test Item Selection Mode, "HoP" is displayed in the left side score LED.
- 2** The time LED displays the sensor states as follows.
(ON: Lighted, OFF: Off)

LED No.	Sensor name	Reference page
	S stopper sensor	Page 136
	S hopper motor sensor	Page 134
	Escalator outlet sensor	Page 141

- 3** Press the act button (yellow) to release and add mini pucks. "on" is displayed in the right side score LED while releasing and adding pucks, and nothing after the mini pucks have been added.



- Even when the machine state is normal, the "S Hopper Idling Error (Err41)" may occur when puck supply operation is performed immediately after installation is complete. In this case, perform the test again.
- Before setting the Test switch to OFF, make sure that there are 16 mini pucks in the mini puck stock areas.

1

2

3

4

5

6

7

8A

8B

9

10

11

12

Test Mode

Test Mode

Troubleshooting

7-8-7 Sound Test

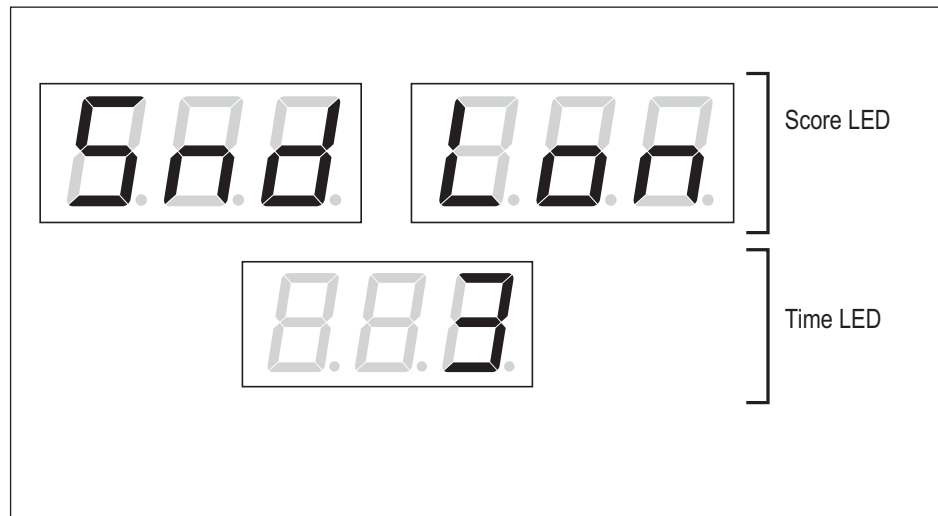

Test item selection display (Sound test)

- 1** In this Test Item Selection Mode, "Snd" is displayed in the left side score LED.
- 2** Press the act button (yellow) to play the speaker test sound from only the L side speaker, only the R side speaker, and both the L and R side speakers, in that order. "on" is displayed in the right side score LED during the speaker test, and nothing after speaker test.
- 3** The sound volume (0 to 15) is displayed in the time LED.

7-9 Setting Mode

The machine displays the setting contents on the signboard that displays the score and timer.

7-9-1 Setting Item Selection Mode

- 1** Use the supplied service key to open the selector door, and set the Test switch to ON (slide the switch upward) while pressing the Enter button (green) to enter the Setting Mode. (See “7-6-2 Adjustment Switches” on page 39.)
- 2** Flip the Select switch up and down to select the item.
- 3** Press the Enter button (green) to enter the selected item.
- 4** Flip the Select switch up and down to select the setting value.
- 5** Press the Enter button (green) to return to the Setting Item Selection Mode.
- 6** After finishing all the settings, set the Test switch to OFF. Changed setting values are saved when the Test switch is set to OFF.
*If the power switch is turned off before the Test switch is set to OFF, the setting values will not be reflected.

1

2

3

4

5

6

7

8A

8B

9

10

11









12

Setting Mode

Test Mode

Troubleshooting

7. Operation

Item order	Item name (Display in Setting Item Selection Mode)	Item	Reference page
1		Number of coins per game	Page 53
2		Number of plays per game	Page 54
3		Play time	Page 55
4		Setting of the random time for mini puck	Page 56
5		Setting of the last time for mini puck	Page 57
6		Attract BGM ON/OFF	Page 59
7		Error log	Page 61
8		Return all settings to default settings (factory settings)	Page 68

7-9-2 Number of coins per game

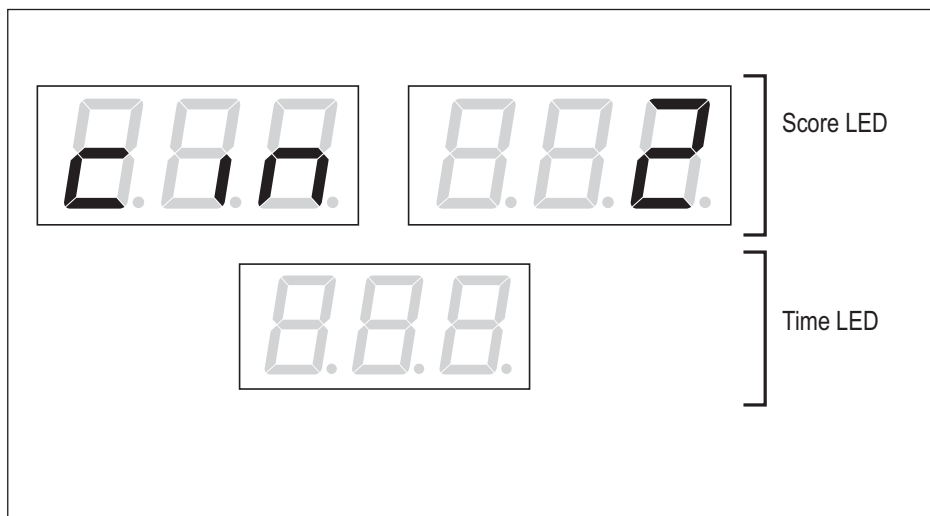

Setting item selection display (Number of coins per game)

- 1** In this Setting Item Selection Mode, “cin” is displayed in the left side score LED and the number of coins is displayed in the right side score LED.
- 2** Press the Enter button (green). The right side score LED display blinks and the machine enters the Setting Change Mode.
- 3** In the Setting Change Mode, flip the Select switch up and down to change the value.
 - The values that can be set are FrE, 1, 2, 3, 4, 5, 6, 7, 8, 9, 10, 11, 12, 13, 14, 15, 16, 17, 18 and 19.
 - Flip the Select switch up to increase the value. The value returns to FrE after 19.
 - Flip the Select switch down to decrease the value. The value returns to 19 after FrE.
 - Set “FrE” to set the Free Play Mode.
 * The default setting (factory setting) is “2”.
- 4** Press the Enter button (green) again to return to the Setting Item Selection Mode.

1

2

3

4

5

6

7

8A

8B

9

10

11

12

Setting Mode

Test Mode

Troubleshooting

7-9-3 Number of plays per game

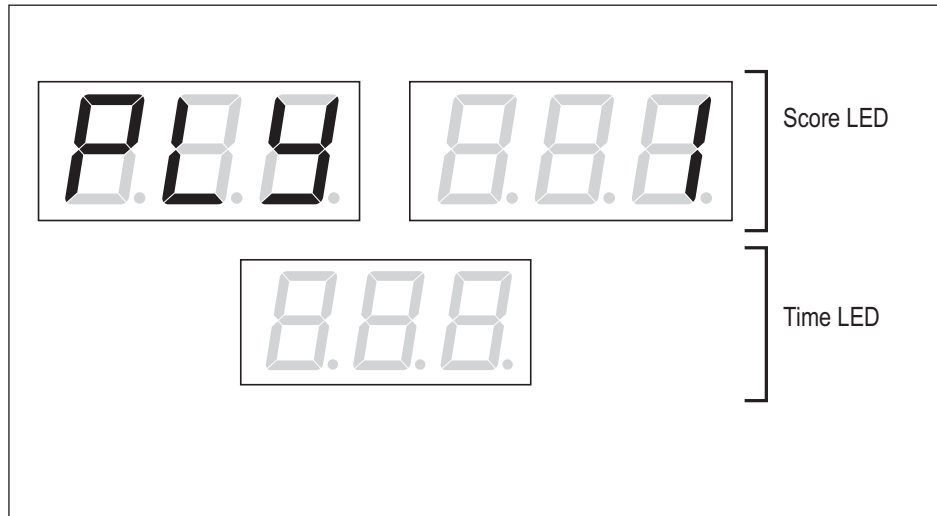

Setting item selection display (Number of plays per game)

- 1** In this Setting Item Selection Mode, "PLY" is displayed in the left side score LED and the number of plays is displayed in the right side score LED.
- 2** Press the Enter button (green). The right side score LED display blinks and the machine enters the Setting Change Mode.
- 3** In the Setting Change Mode, flip the Select switch up and down to change the value.
 - The values that can be set are 1, 2, 3, 4, 5, 6, 7, 8 and 9.
 - Flip the Select switch up to increase the value. The value returns to 1 after 9.
 - Flip the Select switch down to decrease the value. The value returns to 9 after 1.
 * The default setting (factory setting) is "1".
- 4** Press the Enter button (green) again to return to the Setting Item Selection Mode.

7-9-4 Play time

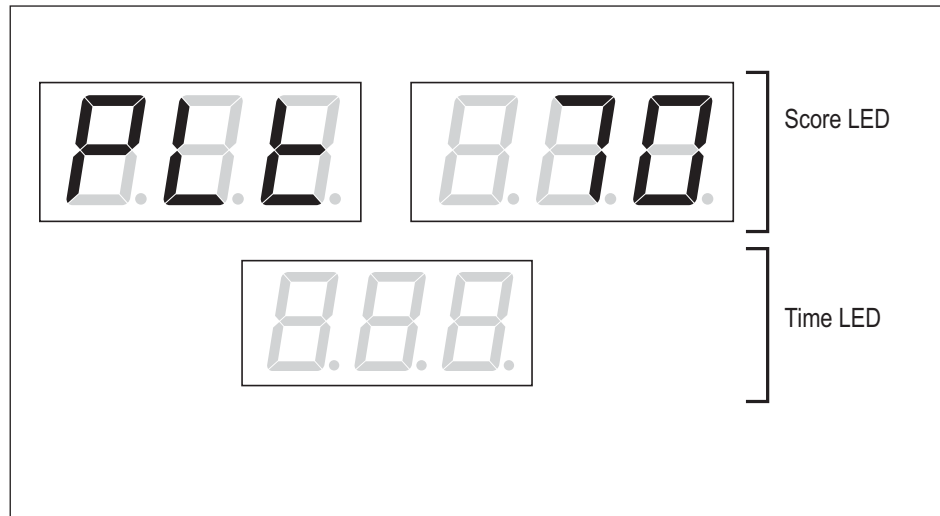

Setting item selection display (Play time)

- 1** In this Setting Item Selection Mode, "PLT" is displayed in the left side score LED and the play time (seconds) is displayed in the right side score LED.
- 2** Press the Enter button (green). The right side score LED display blinks and the machine enters the Setting Change Mode.
- 3** In the Setting Change Mode, flip the Select switch up and down to change the value.
 - The values that can be set are 60, 70, 80, 90, 100, 110, 120, 130, 140, 150, 160, 170, 180, 210, 240, 270 and 300.
 - Flip the Select switch up to increase the value. The value returns to 60 after 300.
 - Flip the Select switch down to decrease the value. The value returns to 300 after 60.
 * The default setting (factory setting) is "70".
- 4** Press the Enter button (green) again to return to the Setting Item Selection Mode.

*The set time may be extended slightly depending on the goal status.

1

2

3

4

5

6

7

8A

8B

9

10

11

12

Setting Mode

Test Mode

Troubleshooting

7-9-5 Setting of the random time for the mini puck

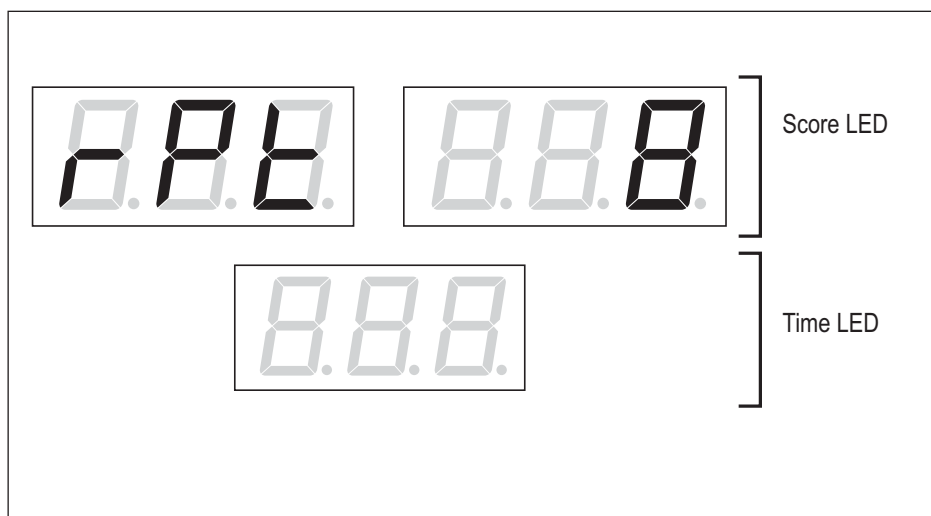

Setting item selection display (Setting of the random time for the mini puck)

- 1** In this Setting Item Selection Mode, "rPt" is displayed in the left side score LED, and during the random time of mini puck (seconds) is displayed in the right side score LED.
- 2** Press the Enter button (green). The right side score LED display blinks and the machine enters the Setting Change Mode.
- 3** In the Setting Change Mode, flip the Select switch up and down to change the value.
 - The values that can be set are 0, 7, 8, 9, 10, 11, 12, 13, 14 and 15.
 - Flip the Select switch up to increase the value. The value returns to 0 after 15.
 - Flip the Select switch down to decrease the value. The value returns to 15 after 0.
 - While selecting 0, mini puck will be released one time only.
 * The default setting (factory setting) is "8".
- 4** Press the Enter button (green) again to return to the Setting Item Selection Mode.

7-9-6 Setting of the last time for the mini puck

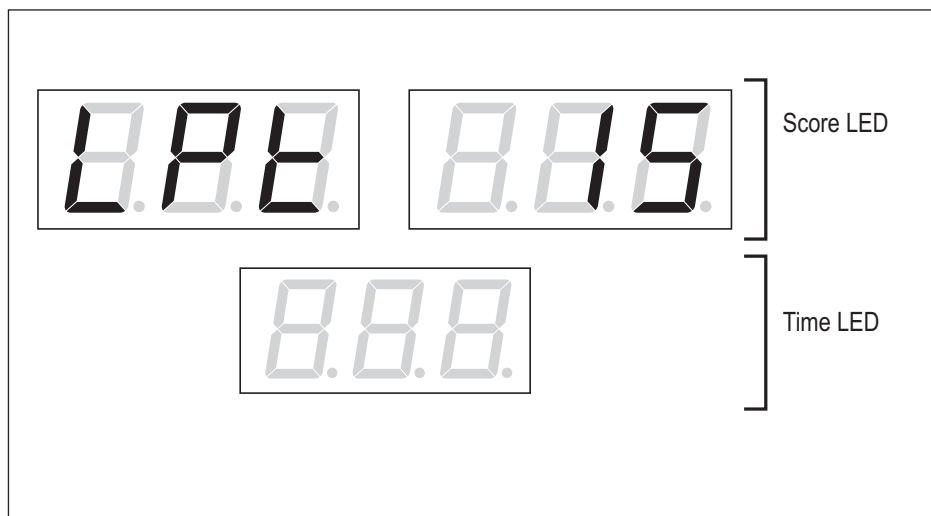

Setting item selection display (Setting of the last time for the mini puck)

- 1** In this Setting Item Selection Mode, "LPT" is displayed in the left side score LED. Before the game is over, the last time of mini puck (seconds) is displayed in the right side score LED.
- 2** Press the Enter button (green). The right side score LED display blinks and the machine enters the Setting Change Mode.
- 3** In the Setting Change Mode, flip the Select switch up and down to change the value.
 - The values that can be set are 7, 8, 9, 10, 11, 12, 13, 14 and 15. However, a time shorter than the play time cannot be set.
 - Flip the Select switch up to increase the value. The value returns to 7 after 15.
 - Flip the Select switch down to decrease the value. The value returns to 15 after 7.
 * The default setting (factory setting) is "15".
- 4** Press the Enter button (green) again to return to the Setting Item Selection Mode.

1

2

3

4

5

6

7

8A

8B

9

10

11

12

Setting Mode

Test Mode

Troubleshooting

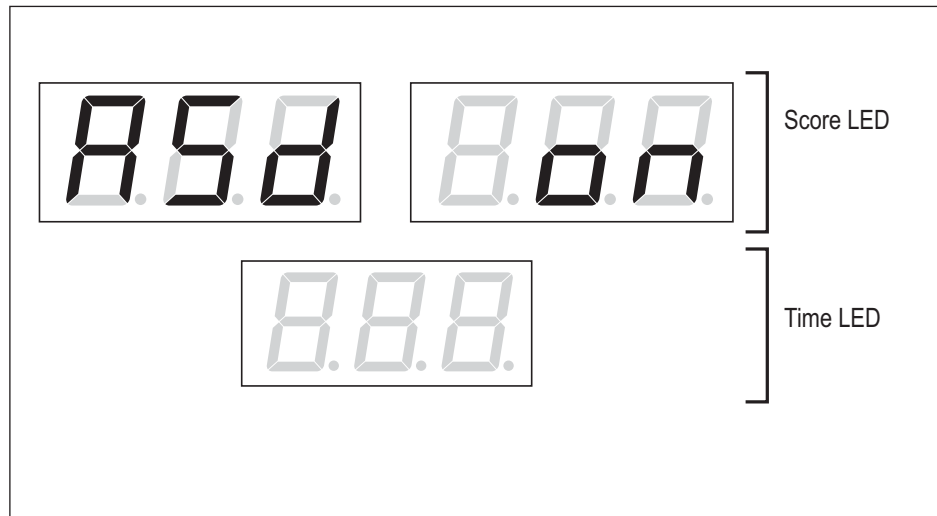
7-9-7 Attract BGM ON/OFF**Setting item selection display (Attract BGM ON/OFF)**

- 1** In this Setting Item Selection Mode, "ASd" is displayed in the left side score LED and "on" or "oFF" is displayed in the right side score LED.
- 2** Press the Enter button (green). The right side score LED display blinks and the machine enters the Setting Change Mode.
- 3** In the Setting Change Mode, flip the Select switch up and down to change the value.
 - The values that can be set are "oFF" (Attract BGM off) and "on" (Attract BGM on).
 - * The default setting (factory setting) is "on" (Attract BGM on).
- 4** Press the Enter button (green) again to return to the Setting Item Selection Mode.

7-9-8 Error log

(1) Number of Errors Saved in Error Log Display Mode

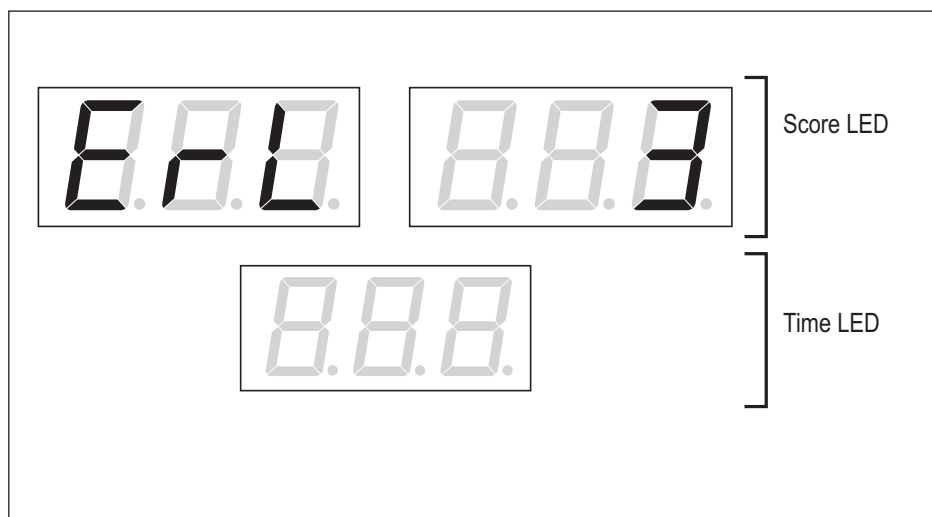

Setting item selection display (Error log)

- 1** In this Setting Item Selection Mode, "ErL" is displayed in the left side score LED and the number of errors saved in the error log is displayed in the right side score LED.
- 2** Press the Enter button (green) to enter the Error Log Contents Display Mode that displays the errors saved in the error log.
 - * The default setting (factory setting) is "0".
 - * The machine can save up to twenty error log entries.

1

2

3

4

5

6

7

8A

8B

9

10

11

12

Setting Mode

Test Mode

Troubleshooting

(2) Error Log Contents Display Mode

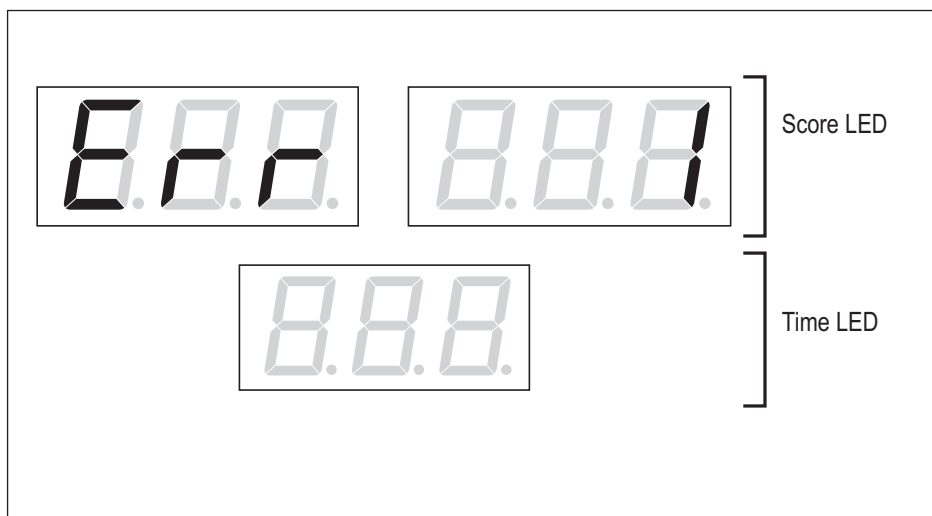

Setting item selection display (Error log contents display mode)

- 1 "Err" is displayed in the score LED, "00" to "19" is displayed in the right side score LED, and the corresponding error code saved in the error log is displayed in the time LED.
 - An error code of "0" indicates that no error is saved.
 - "Err00" is the newest error, and the errors become progressively older as the value increases.
- 2 Flip the Select switch up and down to change the value.
 - Flip the Select switch up to increase the value. The value returns to Err00 after Err19.
 - Flip the Select switch down to decrease the value. The value returns to Err19 after Err00.
- 3 Press the Service button (red) in this error log contents display mode to clear the entire error log.
- 4 Press the Enter button (green) again to return to the Setting Item Selection Mode.

7-9-9 Return all settings to default settings (factory settings)

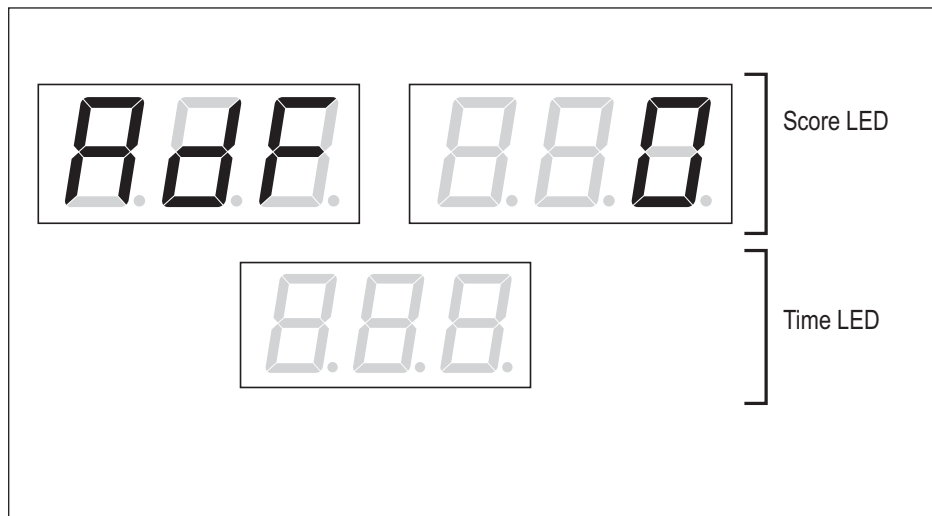

Setting item selection display (Return all settings to default settings (factory settings))

- 1 In this Setting Item Selection Mode, "AdF" is displayed in the left side score LED and a value indicating whether the settings are the same as the default settings (factory settings) is displayed in the right side score LED.
 - The right side score LED displays "0" when the setting values are the default settings (factory settings), or "1" when there are settings other than the default settings (factory settings).
- 2 Press the Enter button (green). The value in the right side score LED starts to blink.
- 3 If the Service switch (red) is pressed while the value in the right side score LED is blinking, all settings are returned to the default settings (factory settings) and the value changes to "0".
- 4 If the Enter button (green) is pressed while the value in the right side score LED is blinking, the value stops blinking and the machine returns to the Setting Item Selection Mode.
 - * The error log are also cleared.

1

2

3

4

5

6

7

8A

8B

9

10

11

12

Setting Mode

Test Mode

Troubleshooting

7-10 Checking the Number of Big Pucks and Adding Big Pucks

The game operation, missing big puck, etc. cause less than two big pucks in the right and left stocks, and the release of big pucks on playing the game might become slowly. Please check the number of big pucks regularly.

- 1** Turn off the power switch.
- 2** Open the Service Door L and Service Door R.
- 3** Count the number of big pucks, and add big pucks.
- 4** To install, perform the procedure in reverse.



Don't put the big pucks into the stock(L) and the stock(R) over two pucks each.
If many pucks are put into the goal at once, the pucks may become jammed inside the machine and prevent normal operation.
Be sure to check the number of big pucks in the stocks.

7-11 Daily Cleaning

7-11-1 Cleaning the Playing Field



- Be careful not to scratch the playing field when cleaning.
- Do not use thinner, benzene, gasoline, alcohol or other organic solvents. This may degrade the materials.
- Do not use wax or other substances that may block the air holes. The pucks will not slide well.
- If the air holes in the playing field become blocked by dust or dirt, the pucks will not slide well. Periodically clean the air holes in the playing field.

- 1 Wipe away any dirt using a soft cloth moistened with water or a neutral cleanser diluted with water and then firmly wrung out.

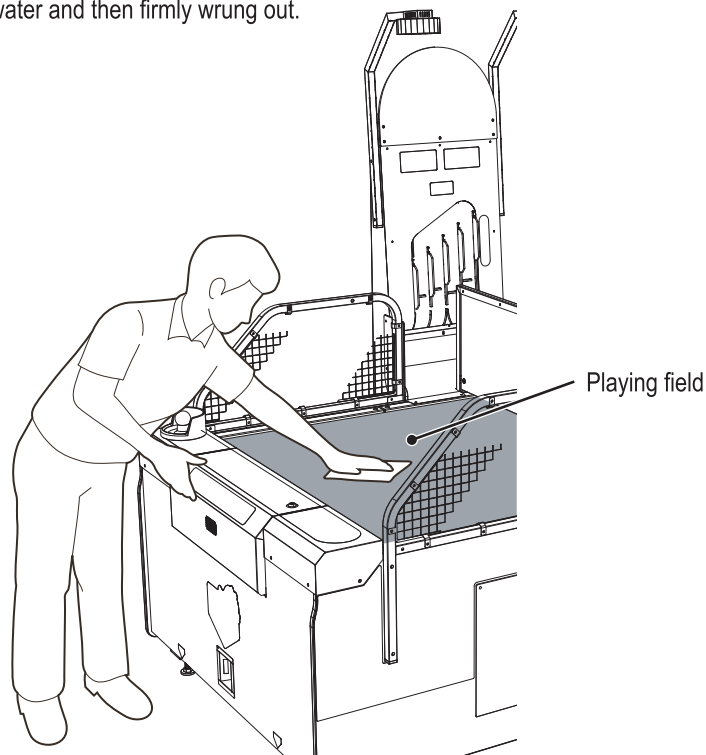

- 2 Wipe dry so that no detergent or water remains, and then allow to dry thoroughly.

- 3 When the air holes are clogged with dust or dirt, insert a paper clip or other pin-like object into the air holes and remove the dirt.



- Check the air holes by sliding a puck over the playing field in the condition with the blower fan rotating. If the puck does not slide well, remove any dust and dirt from the air holes.

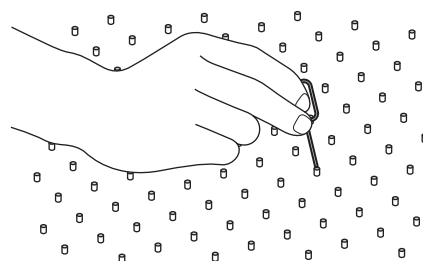

1

2

3

4

5

6

7

8A

8B

9

10

11

12

Checking the Number of Big Pucks and Adding Big Pucks / Daily Cleaning

Test Mode

Troubleshooting

7-11-2 Cleaning the Goal Covers and Corner Covers



- Do not use thinner, benzene, gasoline, alcohol or other organic solvents. This may degrade the materials.

- 1 Wipe away any dirt using a soft cloth moistened with water or a neutral cleanser diluted with water and then firmly wrung out.

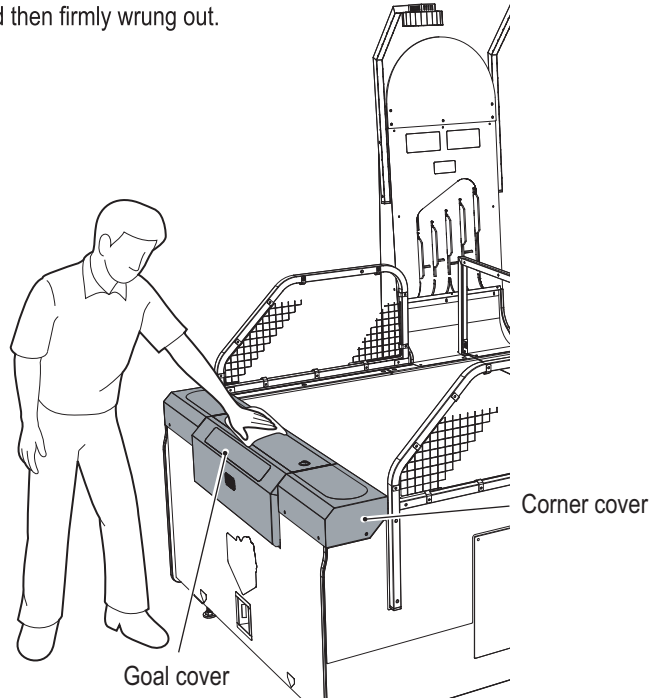

- 2 Wipe dry so that no detergent or water remains, and then allow to dry thoroughly.

7-11-3 Cleaning the Pucks and Mallets



- Do not use thinner, benzene, gasoline, alcohol or other organic solvents. This may degrade the materials.

- 1 Wipe away any dirt using a soft cloth moistened with water or a neutral cleanser diluted with water and then firmly wrung out.

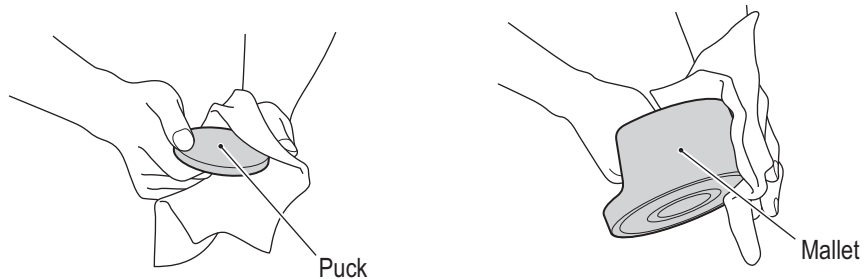

- 2 Wipe dry so that no detergent or water remains, and then allow to dry thoroughly.

7-11-4 Cleaning the Signboard and Cover Panel

**NOTICE**

- Do not use thinner, benzene, gasoline, alcohol or other organic solvents. This may degrade the materials.

- 1** Wipe away any dirt using a soft cloth moistened with water or a neutral cleanser diluted with water and then firmly wrung out.

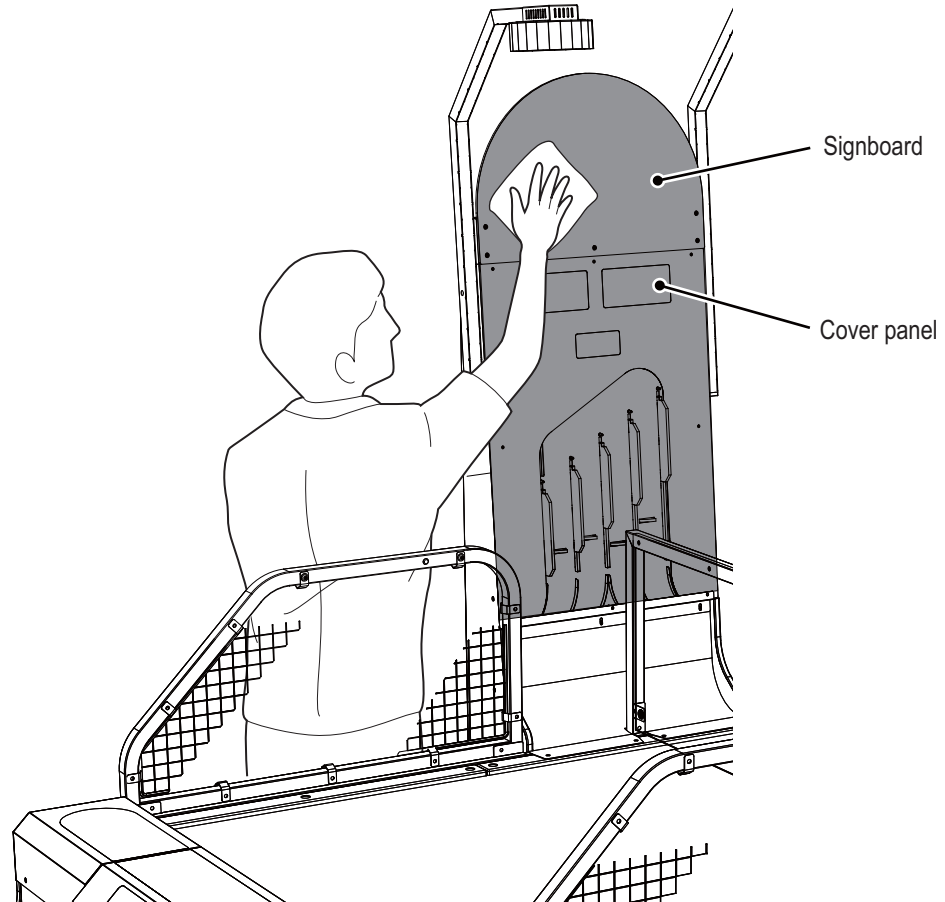

- 2** Wipe dry so that no detergent or water remains, and then allow to dry thoroughly.

1

2

3

4

5

6

7

8A

8B

9

10

11

12

Daily Cleaning

Test Mode

Troubleshooting

7-11-5 Cleaning the Sloped Areas



- Do not use thinner, benzene, gasoline, alcohol or other organic solvents. This may degrade the materials.

- 1 Wipe away any dirt using a soft cloth moistened with water or a neutral cleanser diluted with water and then firmly wrung out.

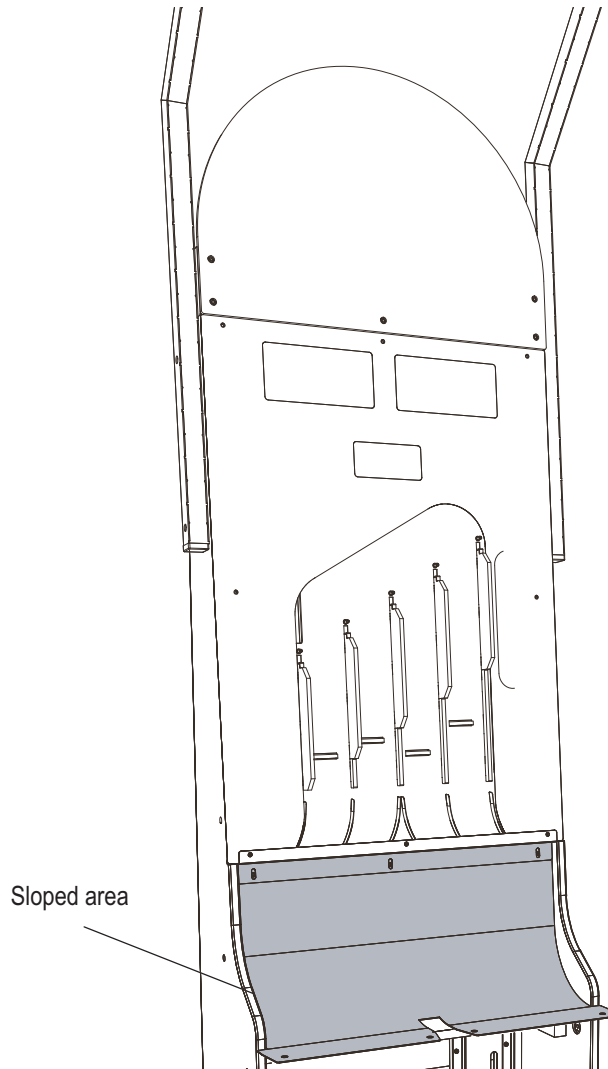

- 2 Wipe dry so that no detergent or water remains, and then allow to dry thoroughly.

8. Technician's Manual - Must be performed by a technician -

8A. Installation and Assembly

8A-1 Number of Workers, Work Time and Work Space

8A-1-1 Number of Workers and Work Time

(1) Number of Workers

The work should be performed by four technicians.

(2) Work Time

The estimated work time for four workers (technicians) is 2 hours.

8A-1-2 Securing Work Space

Secure the following space around the cabinet for performing the installation work.

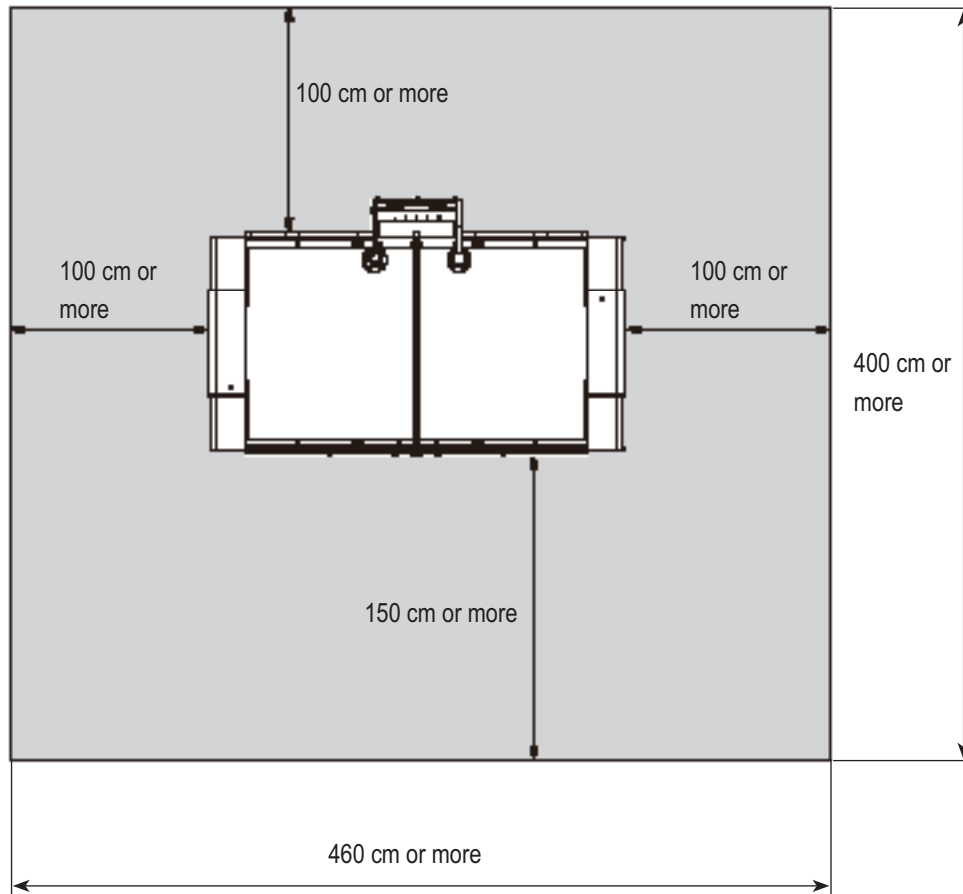

1

2

3

4

5

6

7

8A

8B

9

10

11

12

Number of Workers, Work Time and Work Space

Test Mode

Troubleshooting

- Must be performed by a technician -

8A-2 Assembly

8A-2-1 Assembling the Table

(1) Assembling the Table, Goals and Corner Covers

- 1 Join the cabinet (L) and (R) assemblies with 9 Phillips hexagon socket head bolts (with flat and spring washers) (M8 x 35) and 9 flat washers ($\Phi 9 \times \Phi 30$), and connect the six connectors.

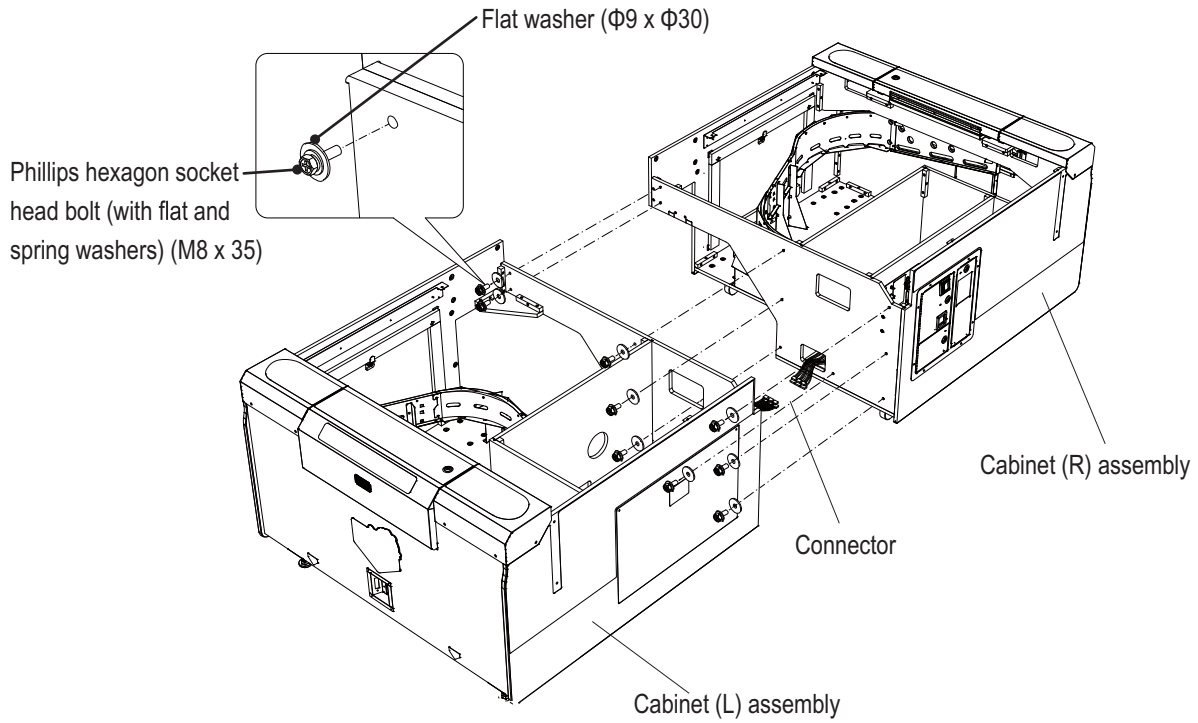

- 2 Open the coating clip, and release the bundled harness.

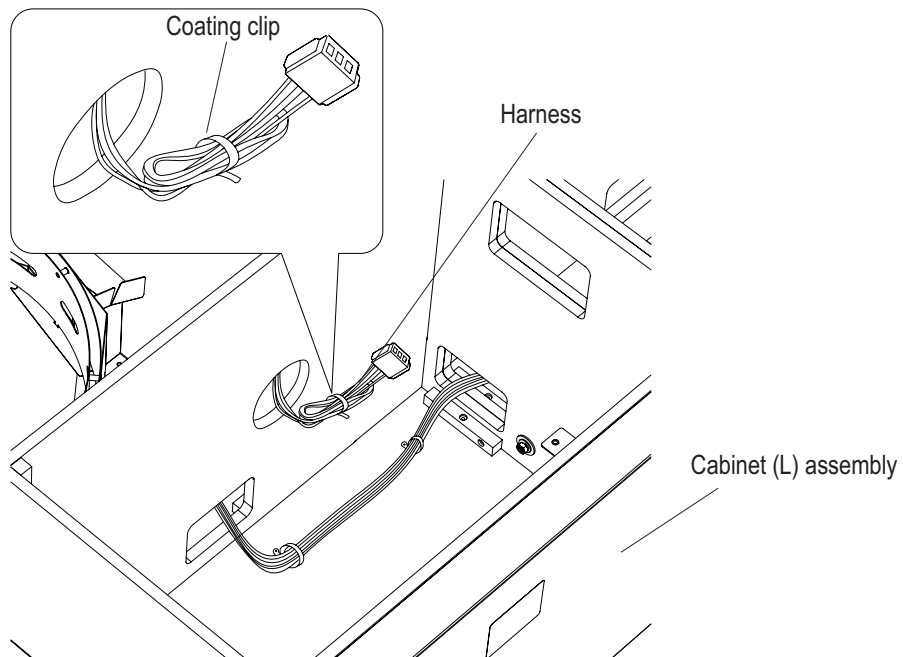

- Must be performed by a technician -

3 Open the goal (L) assembly. (See "7-5-3 Opening and Closing the Goal (L) and (R) Assemblies" on page 38.)

4 Disconnect the connector.

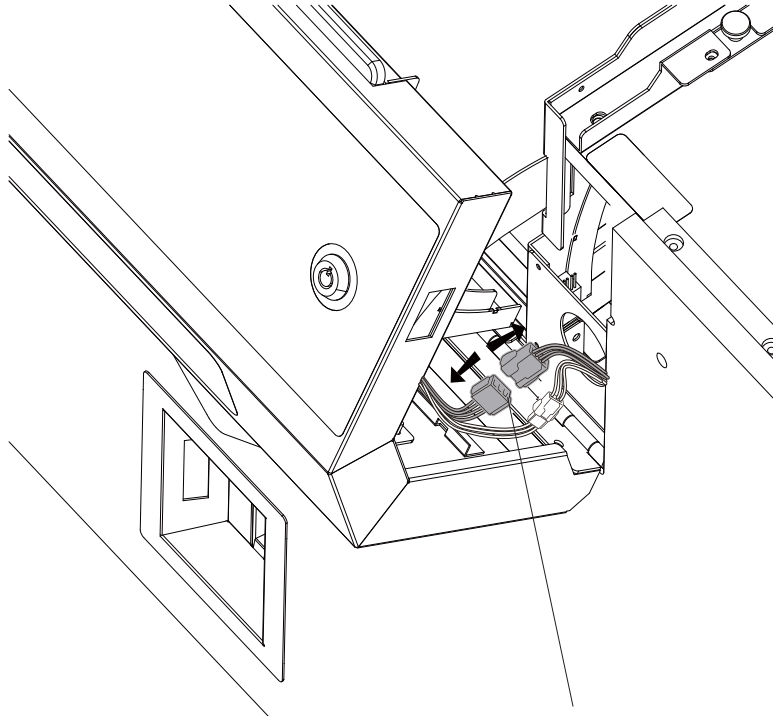

Connector

5 Remove the four Phillips hexagon socket head bolt (with flat and spring washers) (M6 x 16).

Phillips hexagon socket head bolt (with flat and spring washers) (M6 x 16)

Goal (L) assembly

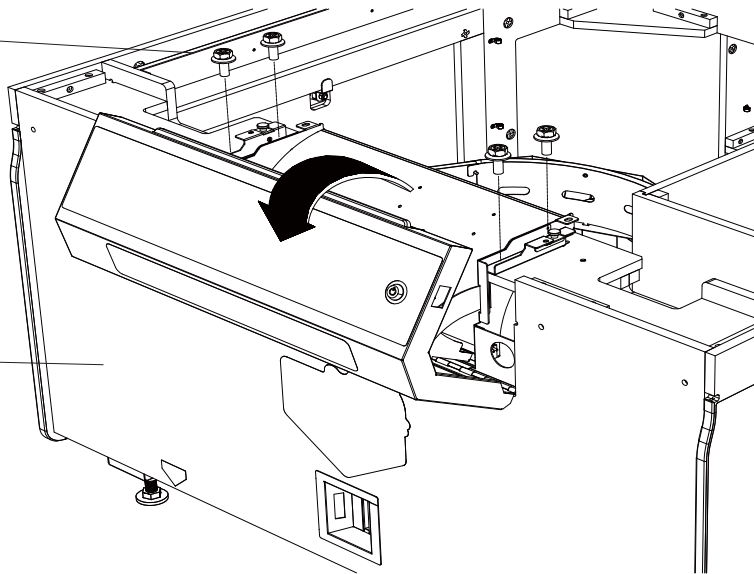

1
2
3
4
5
6
7
8A
8B
9
10
11
12
Assembly

Test Mode
Troubleshooting

8A. Installation and Assembly

- Must be performed by a technician -

- 6** Close the goal (L) assembly. (See “7-5-3 Opening and Closing the Goal (L) and (R) Assemblies” on page 38.)
- 7** Lift the goal (L) assembly straight up with two people, and remove it.

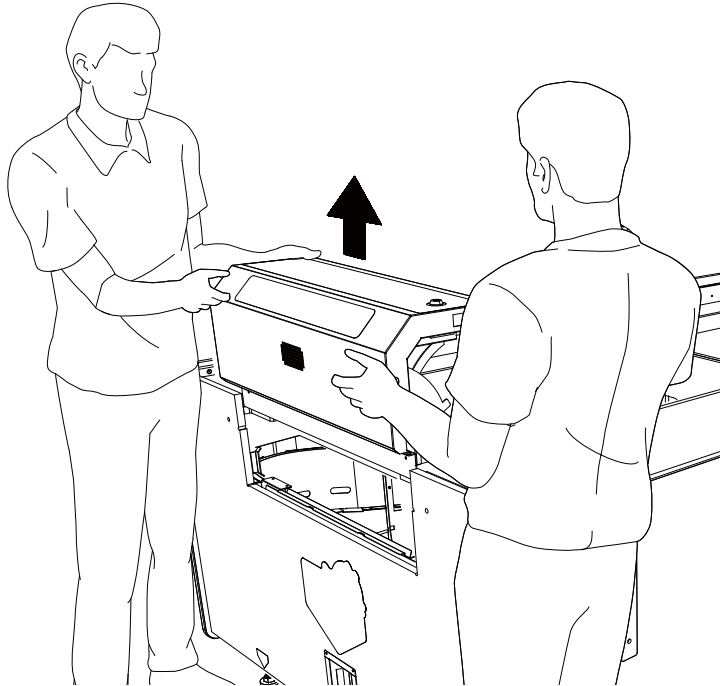

- 8** Follow the same procedure as steps **3** to **7** to remove the goal (R) assembly.
- 9** Attach the center guard bracket (A) with four Phillips hexagon socket head bolt (with flat and spring washers) (M6 x 16).



- Install the center guard bracket (A) in a level manner so that it is not tilted.

Phillips hexagon socket head
bolt (with flat and spring
washers) (M6 x 16)

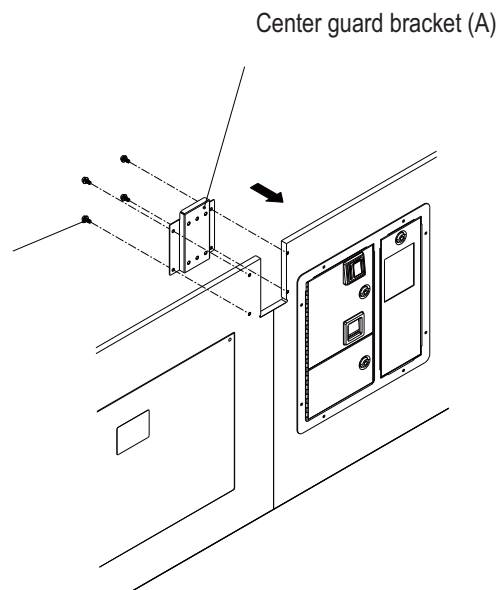

- Must be performed by a technician -

- 10** Attach the blower bracket to the table top assembly with four Phillips hexagon socket head bolt (with flat and spring washers)(5 x 15)

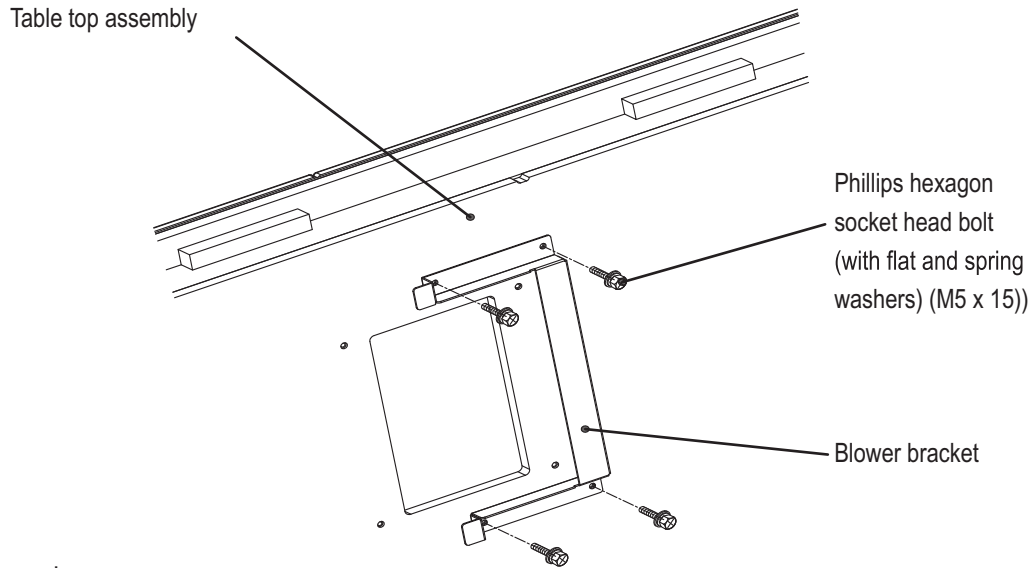

NOTICE

- Do not place the table top assembly on the floor or other location with the surface to the blower bracket is attached on the bottom. Doing so may cause the parts to deform.

CAUTION

- When attaching the table top assembly, be careful where you place your hands to avoid trapping your hands.

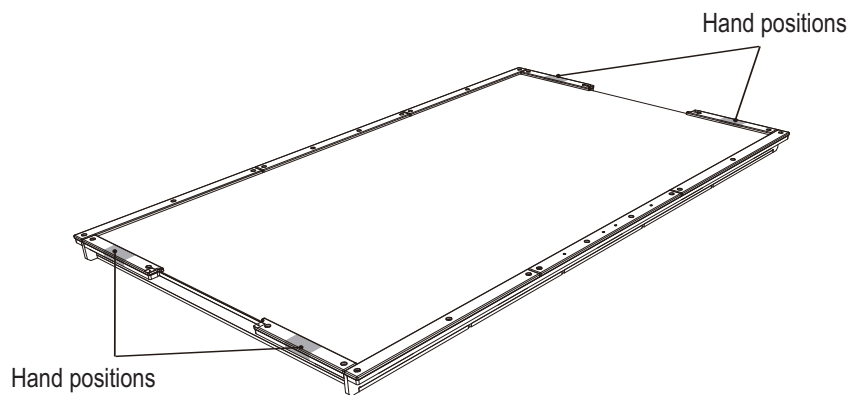

- 11** Lift up the table top assembly with four people as shown in the figure, and fit it onto the top of the cabinet assembled in step **1**.

NOTICE

- The table top assembly has an orientation. Assemble so that the area with the 4-hole table bumper is on the same side as the opening in the cabinet.

1

2

3

4

5

6

7

8A

8B

9

10

11

12

Assembly

Test Mode

Troubleshooting

8A. Installation and Assembly

- Must be performed by a technician -

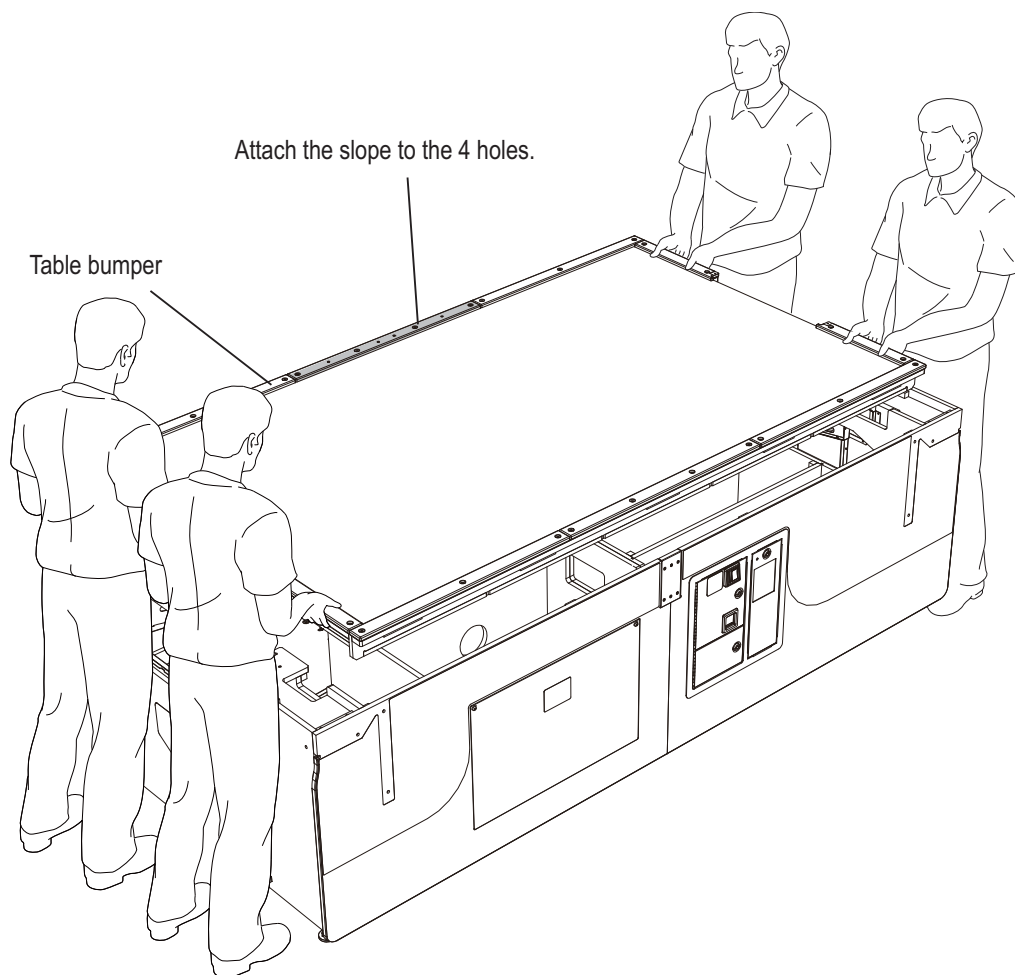

- 12** Attach the table top assembly to the cabinet with eight button head bolts (M6 x 40) and eight flat washers (M6).



- It may be difficult to attach the screws if the floor surface is not level. In these cases, adjust the level adjusters so that the cabinet is level.

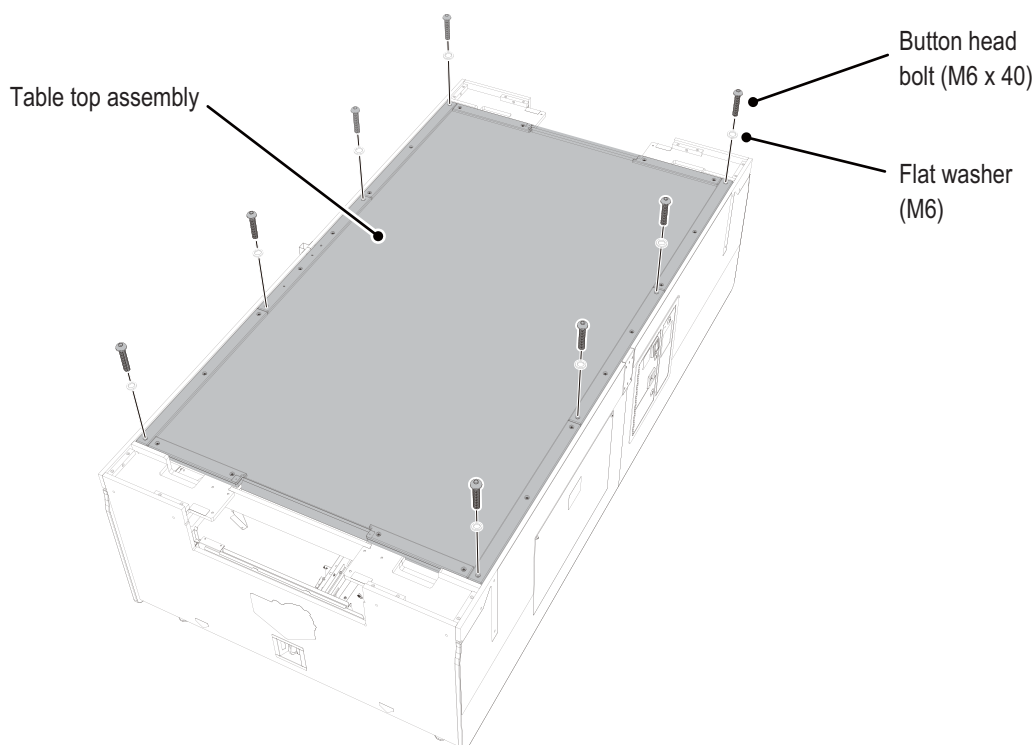

- Must be performed by a technician -

- 13** Insert the goal (L) and (R) assemblies removed in steps **7** and **8** into the cabinet from above. At this time, insert the lower edges of the goal (L) and (R) assemblies into the goal set brackets.

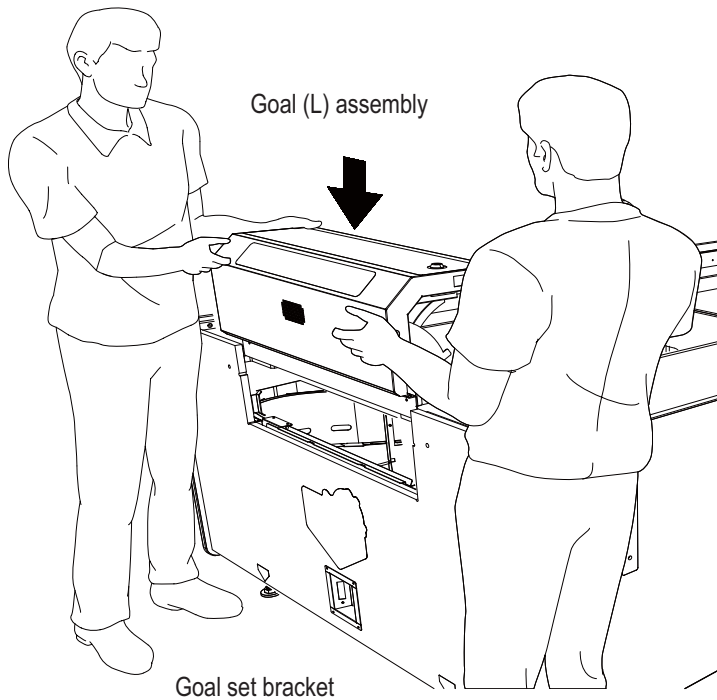

- 14** Open the goal (L) assembly. (See “7-5-3 Opening and Closing the Goal (L) and (R) Assemblies”)
- 15** Connect the connectors.



- Store the excess harness length below the holes so that there is no slack in the connected connectors and harnesses above the holes.

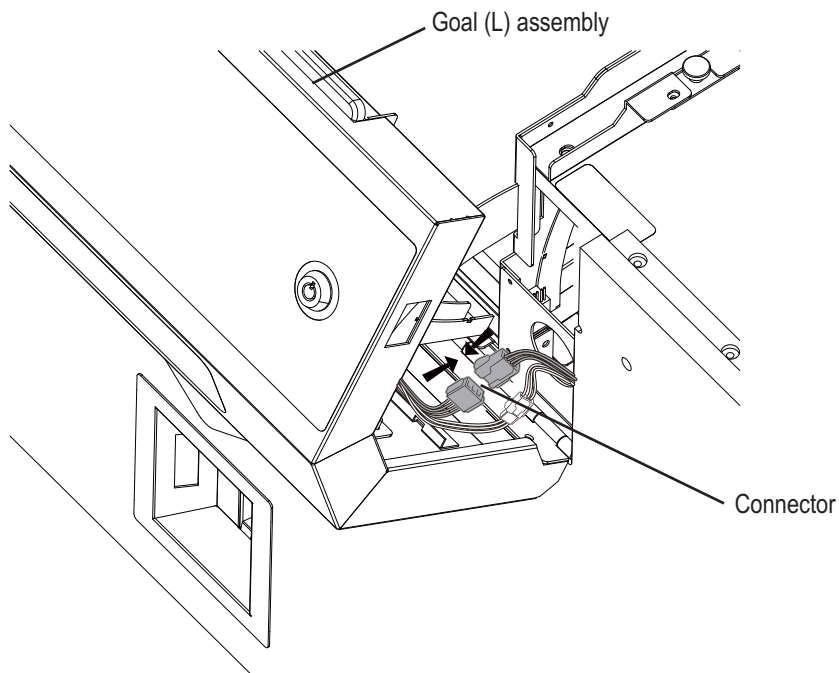

1

2

3

4

5

6

7

8A

8B

9

10

11

12

Assembly

Test Mode

Troubleshooting

8A. Installation and Assembly

- Must be performed by a technician -

- 16** Temporarily secure the goal (L) assembly with the four Phillips hexagon socket head bolt (with flat and spring washers) (M6 x 16) removed in step **5** and two Phillips hexagon socket head bolt (with flat and spring washers) (M5 x 8)

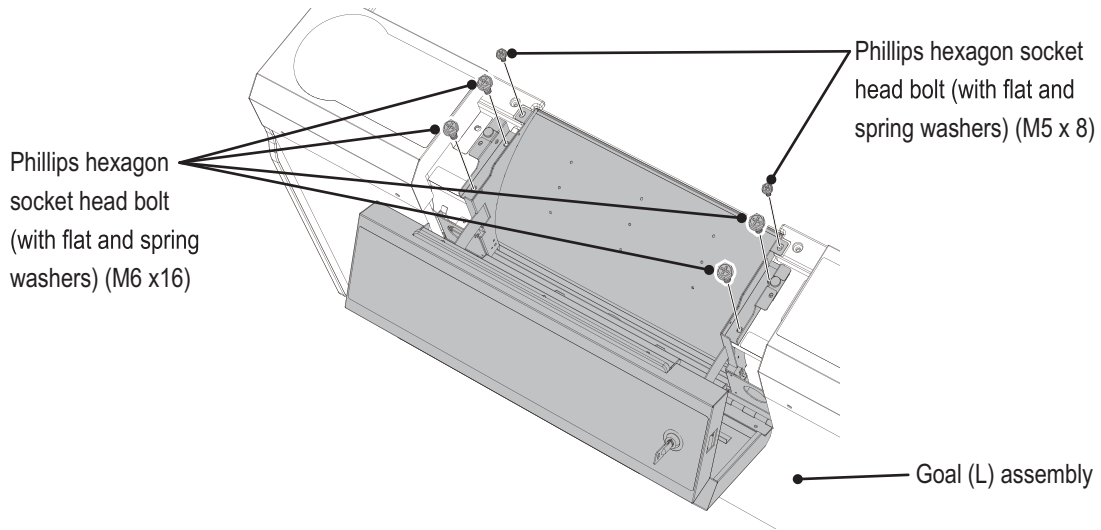

- When installing, be sure to use bolts of the specified length.
- When installing, be careful not to pinch the connectors.

- 17** Follow the same procedure as steps **14** to **16** to temporarily secure the goal (R) assembly.
- 18** Set the corner covers (pink • L, pink • R, green • L and green • R) on the respective corners of the cabinet, and secure them with 16 button head bolts (M6 x 16), and four flat washers (M6) each.

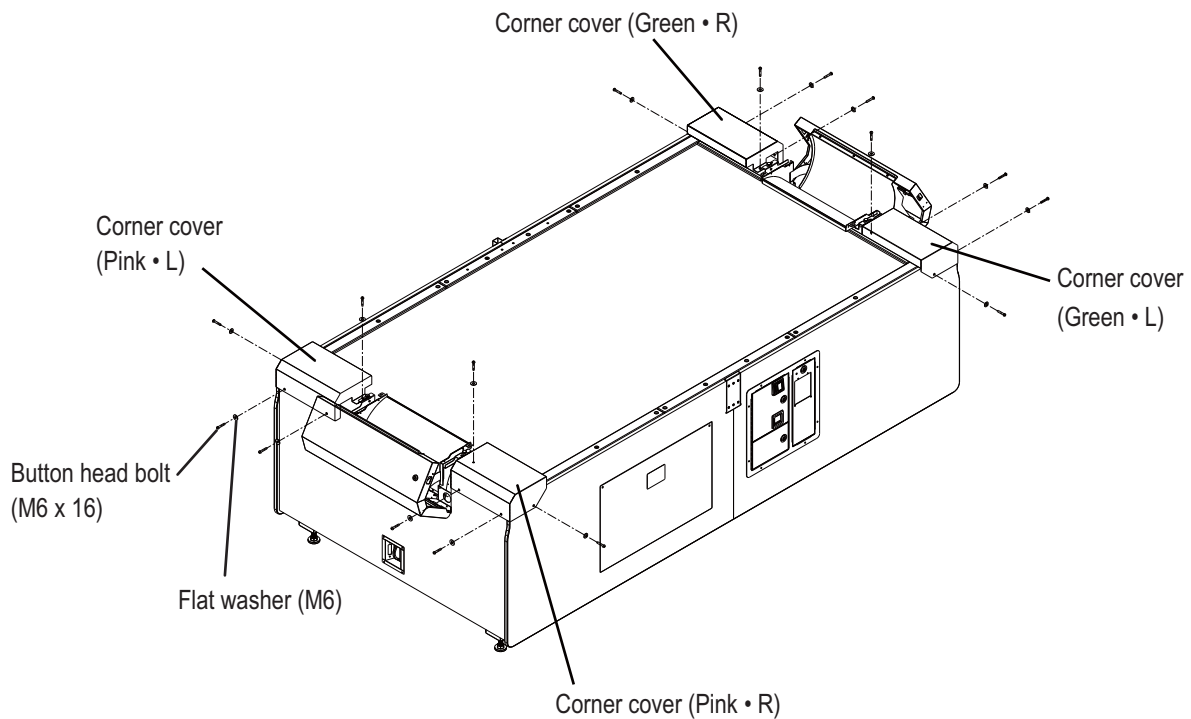

- Must be performed by a technician -



- If any of the bumper fixing screws are loose, tighten the screws.
- When installing, be careful not to pinch the harnesses and connectors.

- 19** Close the goal (L) and (R) assemblies. (See “7-5-3 Opening and Closing the Goal (L) and (R) Assemblies” on page 38.)

(2) Installing the Nets

- 1** Attach the center guard bracket (B) with four Phillips hexagon socket head bolt (with flat and spring washers) (M6 x 16).

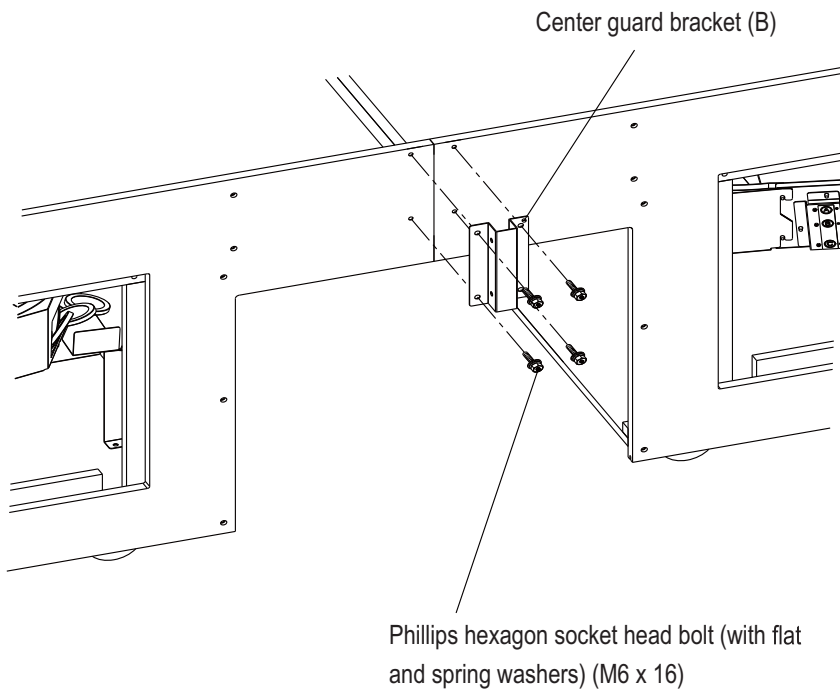

1

2

3

4

5

6

7

8A

8B

9

10

11

12

Assembly

Test Mode

Troubleshooting

8A. Installation and Assembly

- Must be performed by a technician -

- 2** Attach the center guard into the center guard brackets (A), and then secure it with two button head bolts (M6 x 40) and two flat washers (M6).

Insert the center guard into the center guard brackets (B), and then secure it with two button head bolts (M5 x 35), four flat washers (M5) and two cap nut (M5).

*Install the center guard so that the center guard retainer is facing the L side.

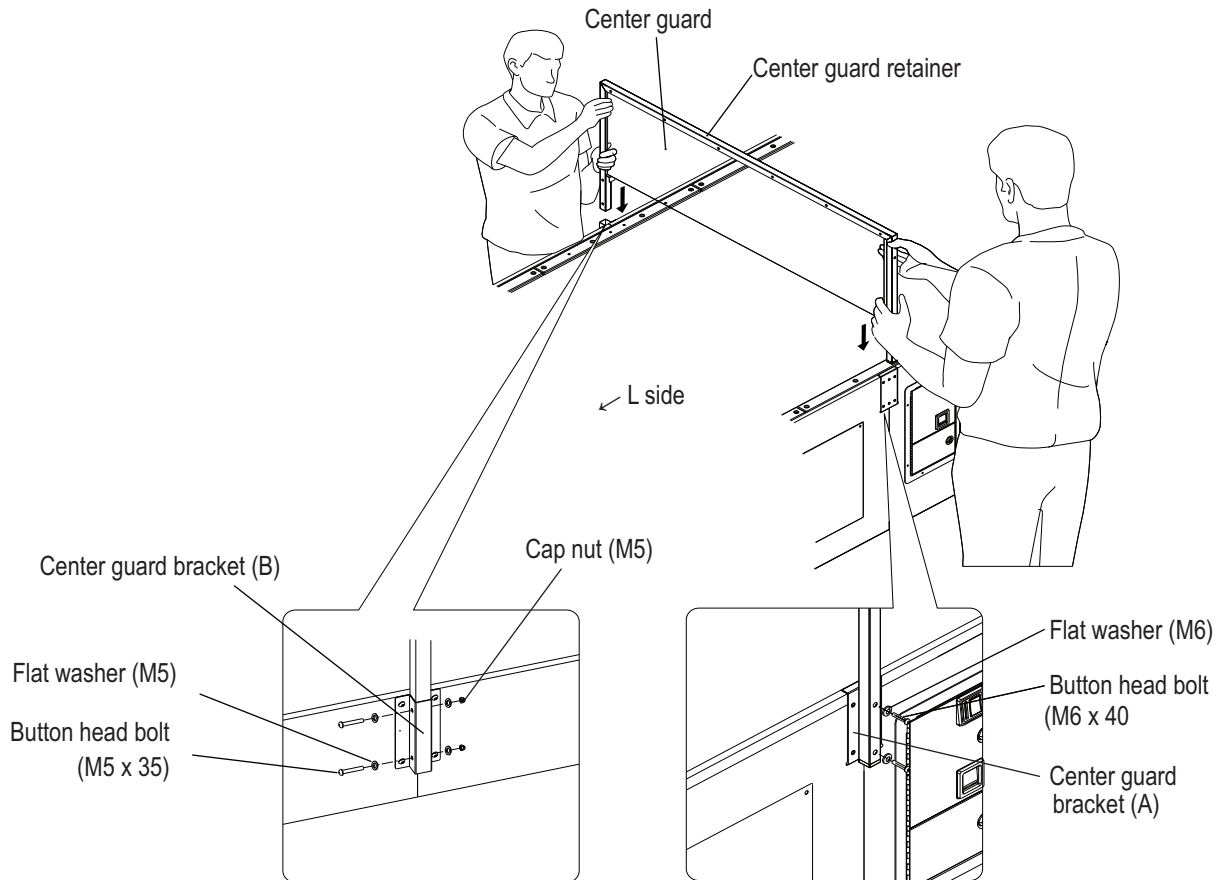

- 3** Insert the hooks of the net S frame (L) into the cabinet (L) assembly, and then secure it with four button head bolts (M6 x 40) and four flat washers (M6).

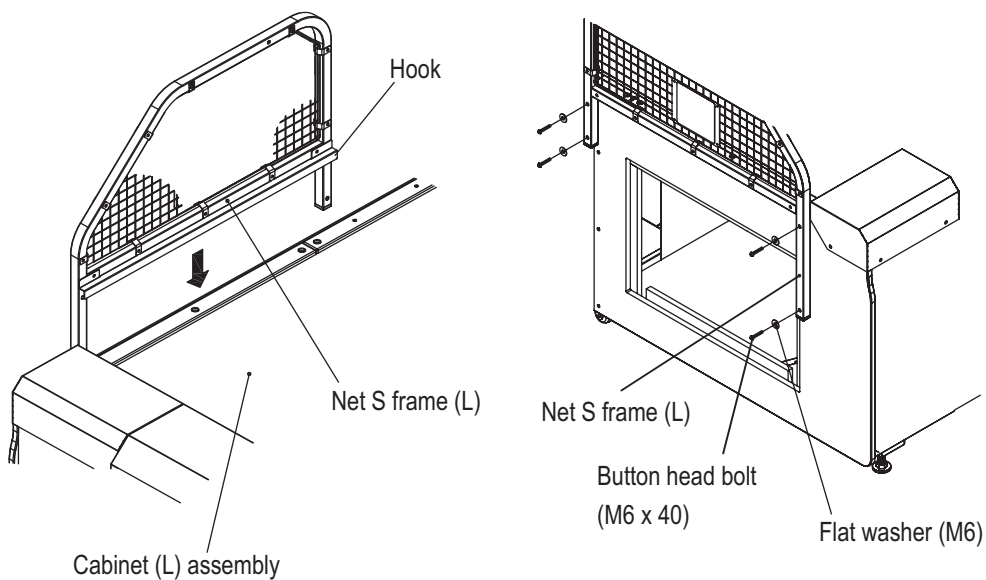

- Must be performed by a technician -

- 4** Follow the same procedure in step **3** to attach the net S frame (R) to the cabinet (R) assembly.
- 5** Insert the hook of the net L frame (L) into the cabinet (L) assembly, and then secure it with four button head bolts (M6 x 40) and four flat washers (M6).

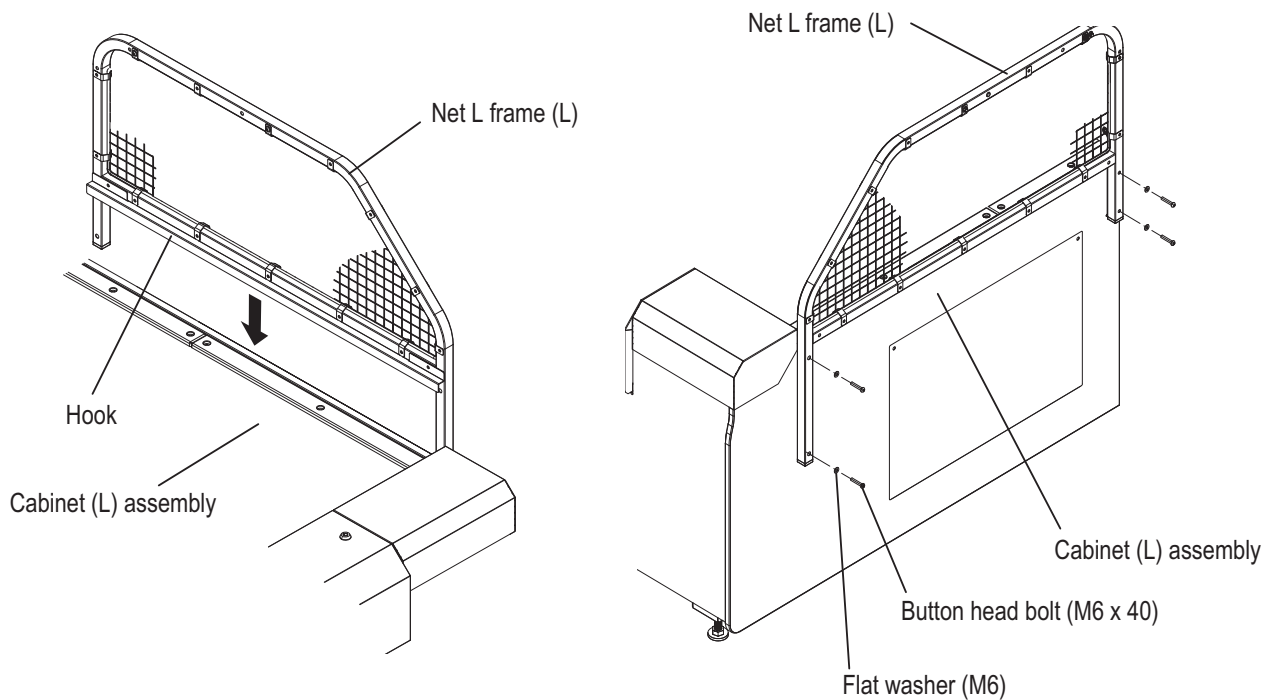

- 6** Follow the same procedure in step **5** to attach the net L frame (R) to the cabinet (R) assembly.
- 7** Attach the triangle bracket with five button head bolts (M5 x 35), ten flat washers (M5) and five cap nut (M5)..

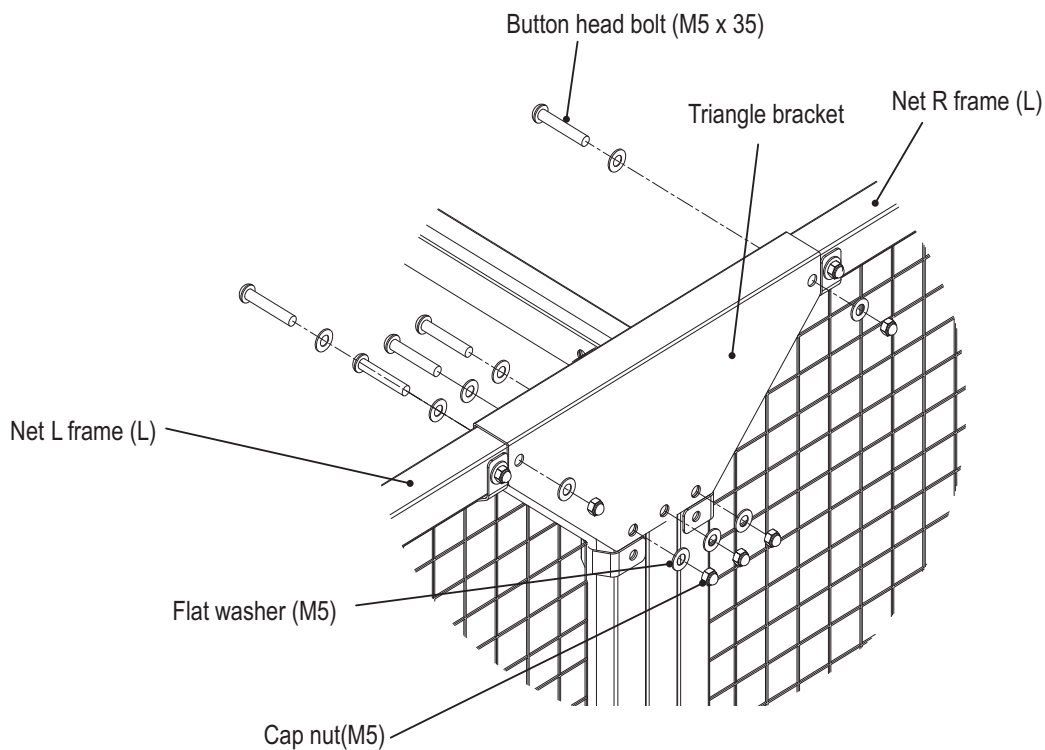

1

2

3

4

5

6

7

8A

8B

9

10

11

12

Assembly

Test Mode

Troubleshooting

- Must be performed by a technician -

(3) Installing the Blower Fan

- 1** Remove the front door. (See “8A-5-1 Opening and Closing the Front Doors” on page 67.)
- 2** Insert the blower mounting plate into the blower bracket from the goal (L) side, and secure it with four cap bolts (M5 x 30) , four flat washers (M5) and sprong washers (M5).
- 3** Connect the connector.

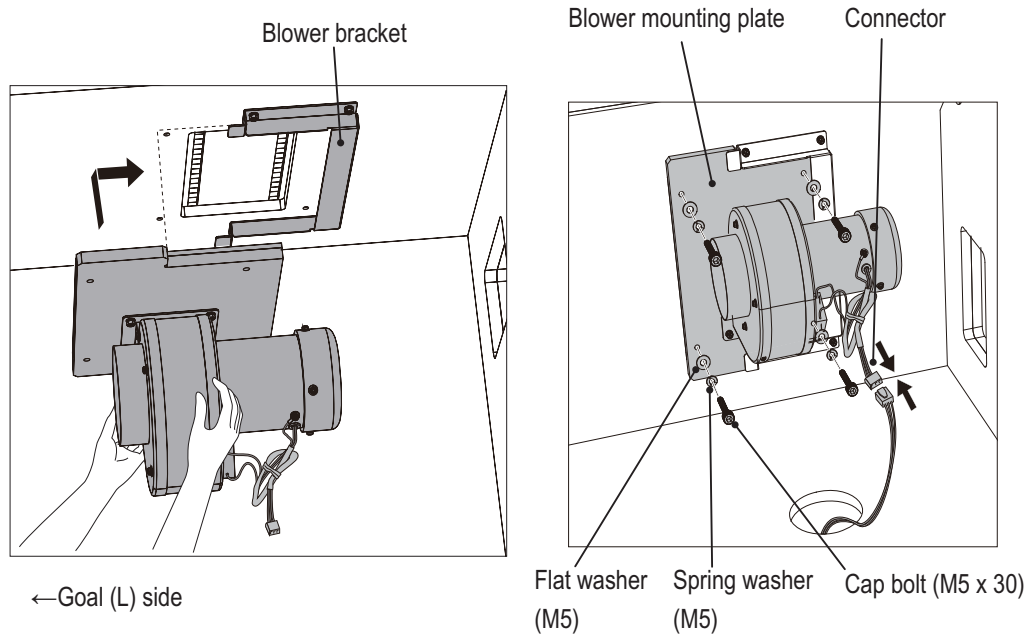

- 4** Reattach the front door. (See “8A-5-1 Opening and Closing the Front Doors” on page 67.)

- Must be performed by a technician -

8A-2-2 Level Adjuster Adjustment

! WARNING

Adjust the level adjusters so that the table casters are at a height of approximately 5 mm from the floor. (The casters should be able to turn freely.) If the machine is unstable, it may move during game play.

NOTICE

Adjust the level adjusters so that the table top surface is level. If the table top surface is tilted excessively, it may be difficult to collect the pucks and the machine may not function properly.

- 1** Install the table in accordance with "5-1 Installation Conditions" on page 24.
- 2** Adjust the level adjusters (four locations) so that the table casters are at a height of approximately 5 mm from the floor.
- 3** Secure the level adjusters with the lock nuts.

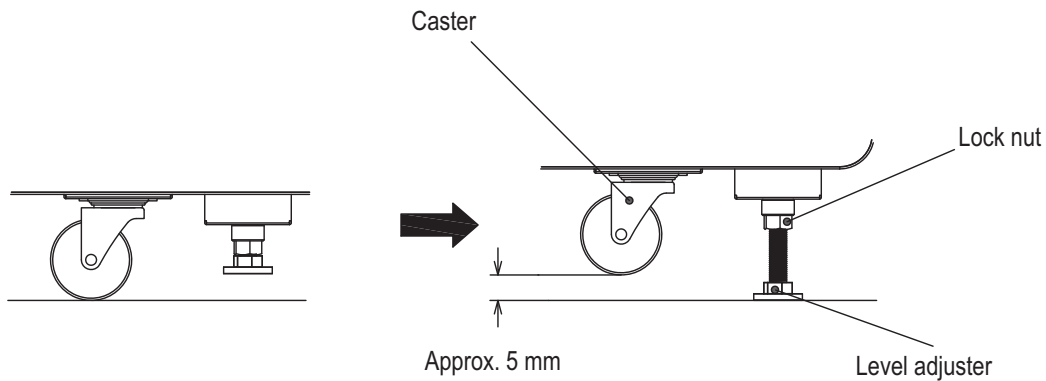

1

2

3

4

5

6

7

8A

8B

9

10

11

12

Assembly

Test Mode

Troubleshooting

8A. Installation and Assembly

- Must be performed by a technician -

8A-2-3 Assembling the Side Tower Assembly

- 1 Attach the signboard with three Pan head bolt (with flat and spring washers) (M4 x 8).

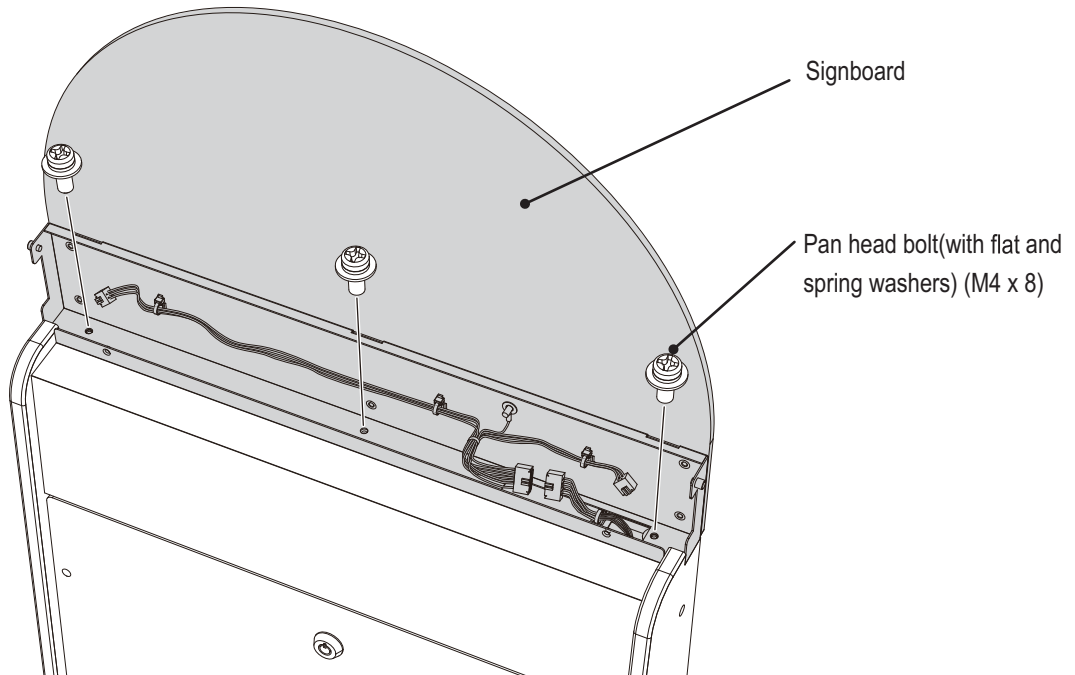

- Must be performed by a technician -

8A-2-4 Installing the Light Assembly

! WARNING

The light assembly is installed while standing in a high location. Use a stool or similar platform. Working in an unnatural body posture may cause an injury or machine damage.

- 1** Attach the light arm L with four button head bolts (M6 x 40) and four flat washers (Φ6 x Φ16).
- 2** Follow the same procedure to install the light arm R.

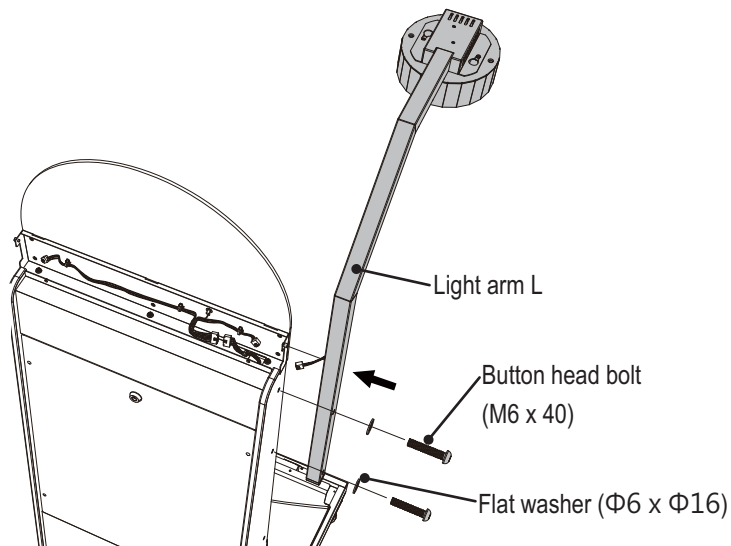

- 3** Connect the three connectors

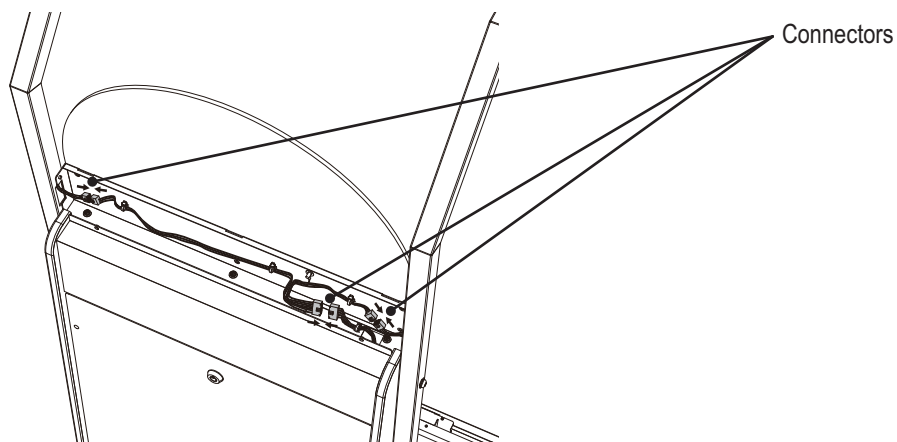

1

2

3

4

5

6

7

8A

8B

9

10

11

12

Assembly

Test Mode

Troubleshooting

8A. Installation and Assembly

- Must be performed by a technician -

- 4 Attach the signboard base cover with two Torx bolt (M4 x 8).

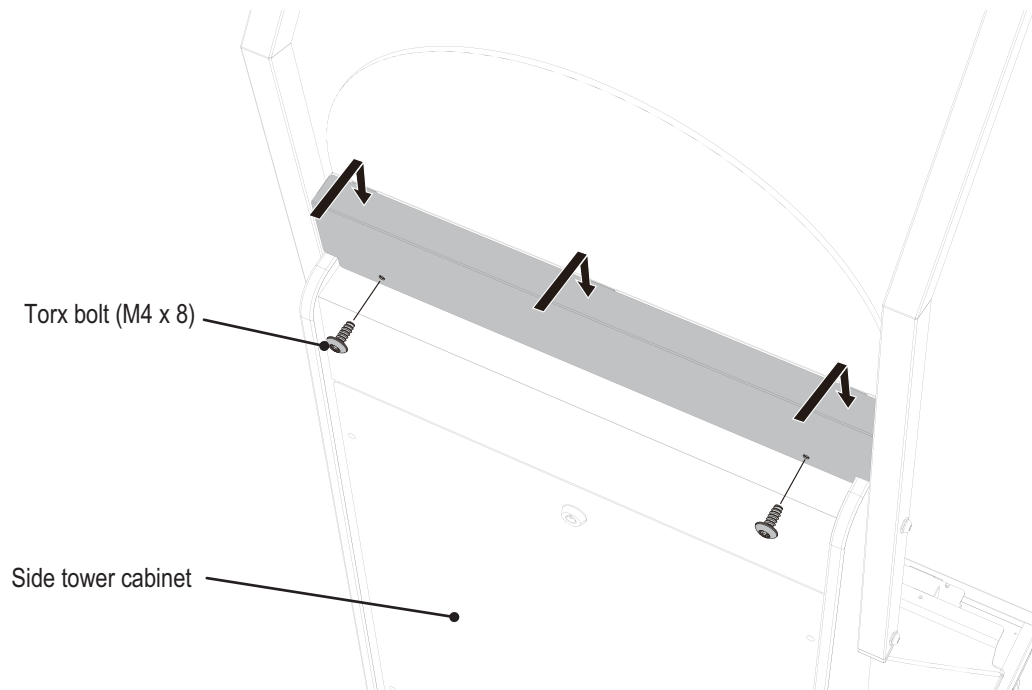

- Must be performed by a technician -

8A-2-5 Installing the Side Tower Assembly

- 1 Lead out the seven connectors from the right and left holes in the front of the side tower cabinet.

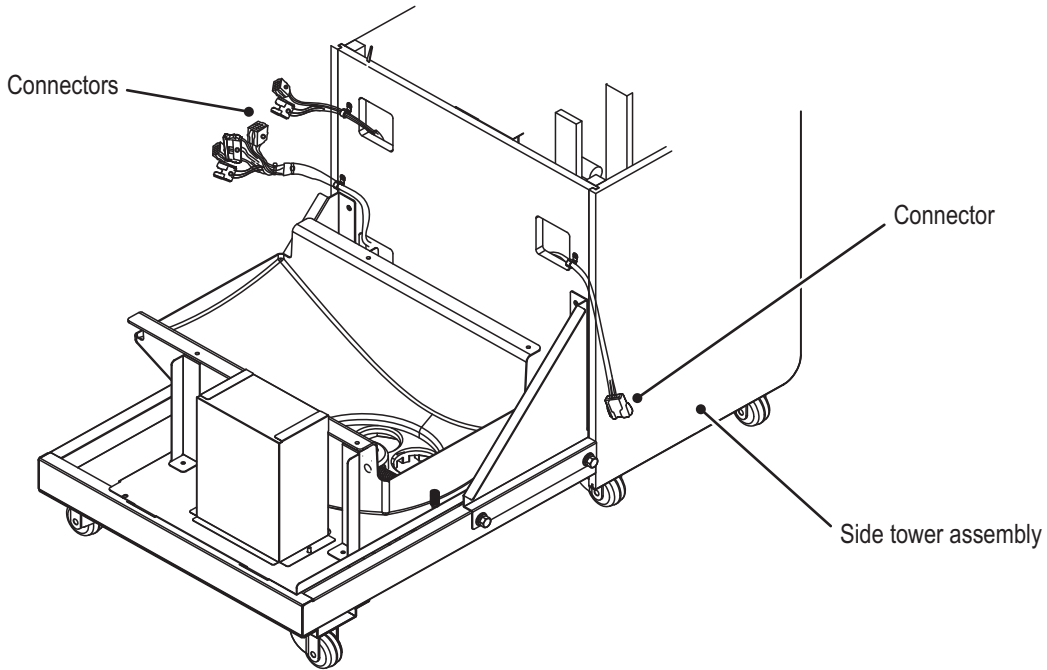

- 2 Attach the side tower bracket with three Button head bolts (M6 x 16) each.

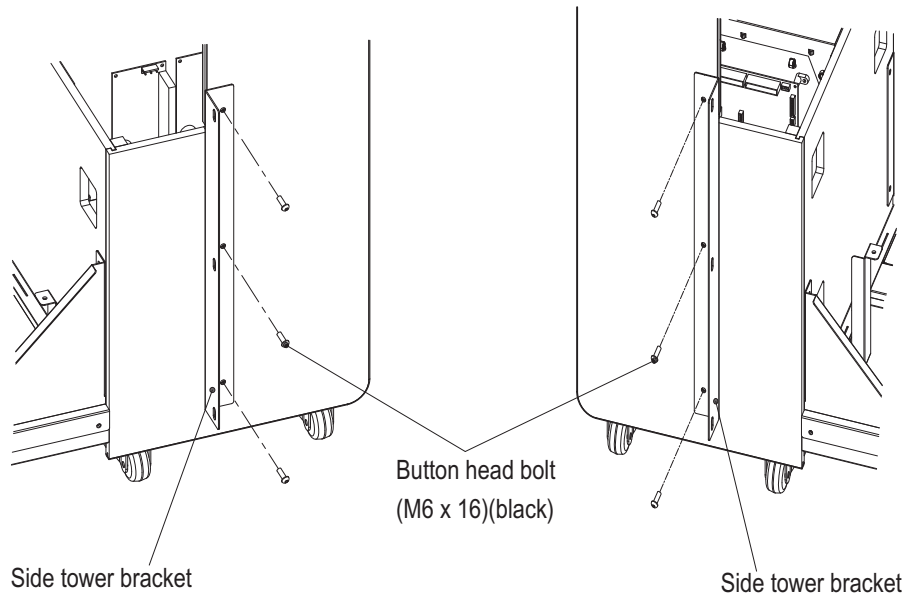

1
2
3
4
5
6
7
8A
8B
9
10
11
12

Assembly

Test Mode

Troubleshooting

8A. Installation and Assembly

- Must be performed by a technician -

- 3 While lifting up the sloped area of the side tower assembly, insert the side tower assembly into the opening in the side surface of the table until the front of the side tower assembly touches the side surface of the table.

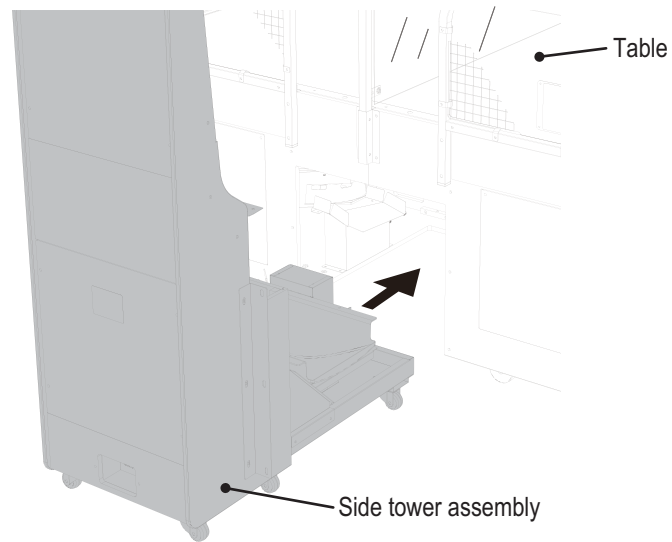

- 4 Attach the side tower assembly to the table with six Button head bolts (BLACK) (M6 x 16).

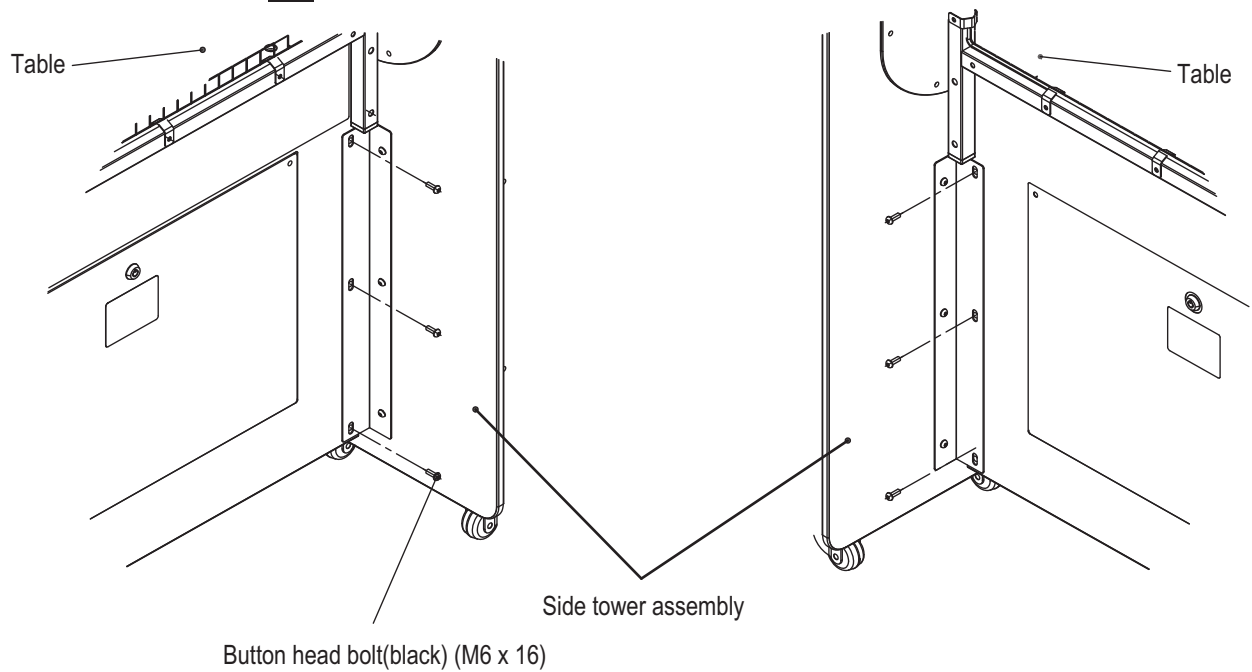

- Must be performed by a technician -

- 5** Loosen the three Torx bolt (M4x 8). Attach the side tower assembly with four countersunk cap bolts (M4 x 8).

- 6** Retighten the three Torx bolt (M4x 8) in step **5**

Torx bolt (M4x 8)(loosen)

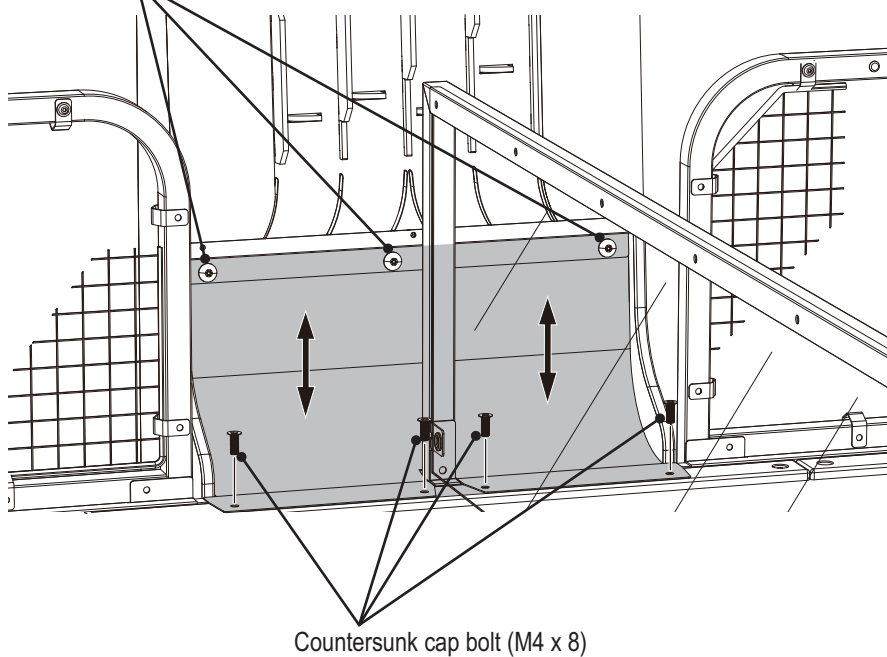

- 7** Remove the service door R. (See "8A-5-2 Opening and Closing the Service Doors L and R" on page 67.)

- 8** Connect the six connectors inside the cabinet (L) assembly.

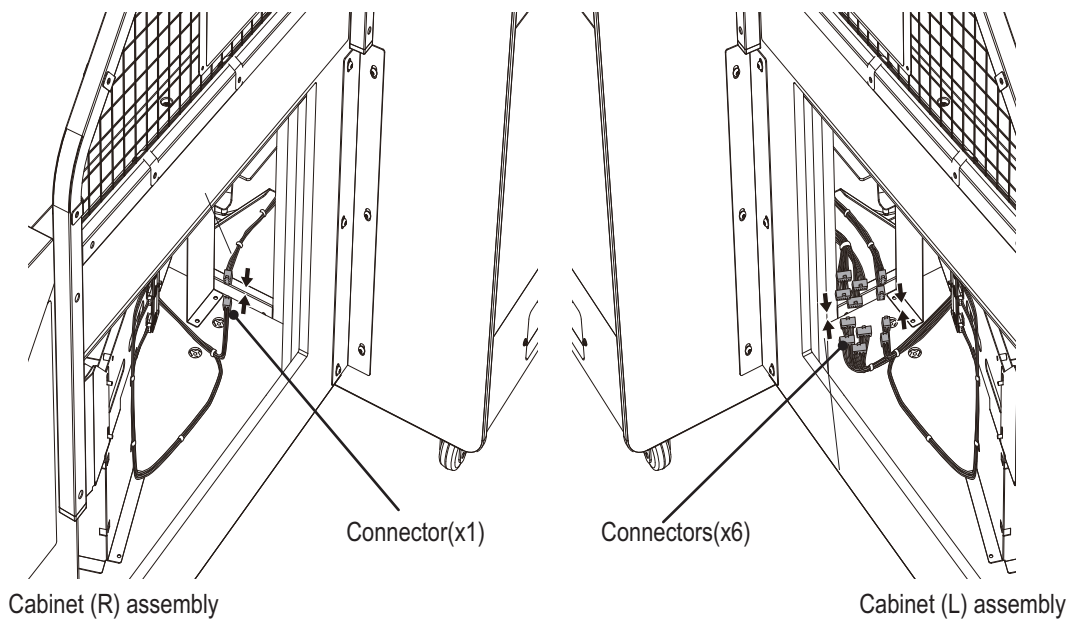

- 9** Connect the connector inside the cabinet (R) assembly.

- 10** Attach the service door R and and L. (See "8A-5-2ening and Closing the Service Doors L and

1

2

3

4

5

6

7

8A

8B

9

10

11

12

Assembly

Test Mode

Troubleshooting

8A. Installation and Assembly

- Must be performed by a technician -

R" on page 67.)

- 11** Attach the two side walls with three Button head bolt (M6 x 16) each.

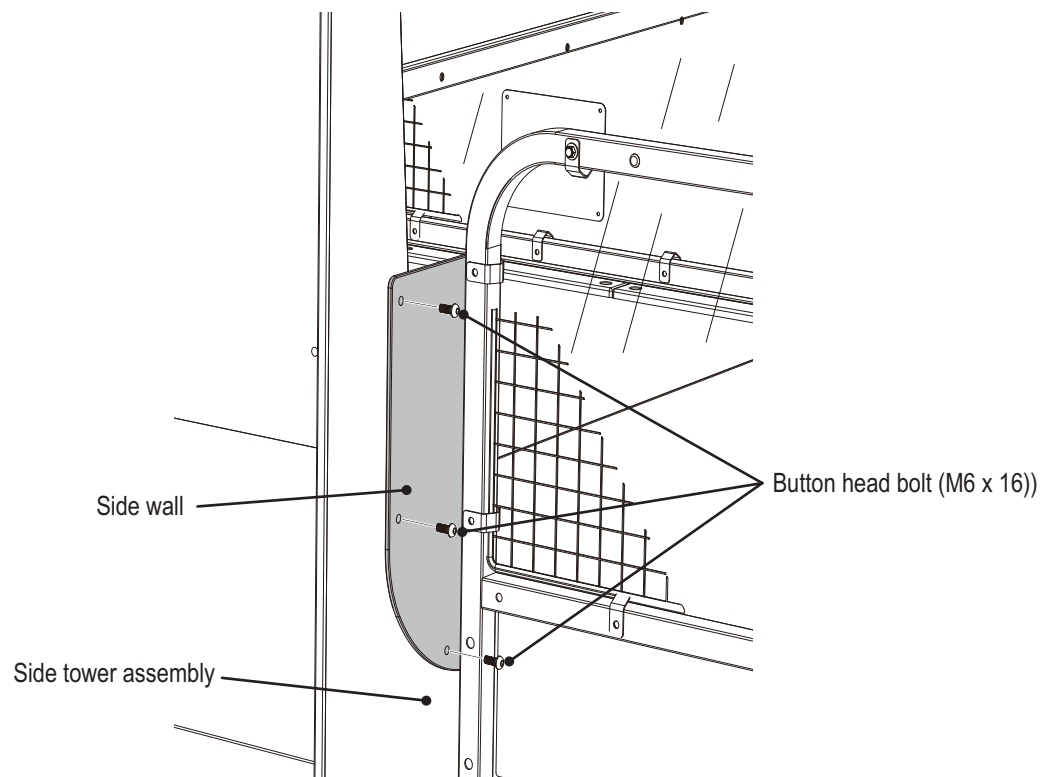

[This completes the assembly work. Go to "8A-2-6 Preparing the Pucks and Mallets". If the bolt holes were not aligned in step 7, perform the procedure below.]

8A-2-6 Preparing the Pucks and Mallets

- 1** Place the mallets on the corner covers.

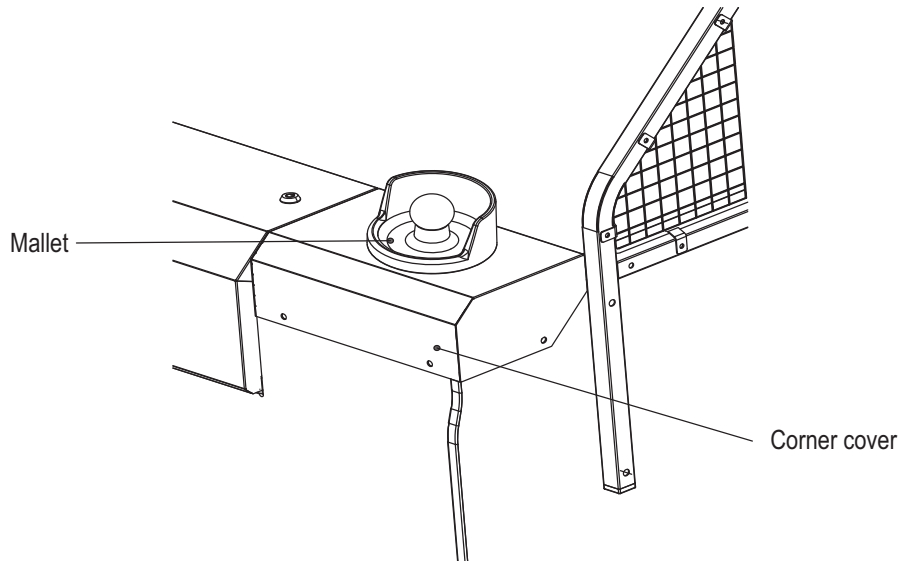

- 2** Put two big pucks into the goal (L) and the goal (L) each, and 50 of the mini pucks (green, pink, orange) into the goal (L).

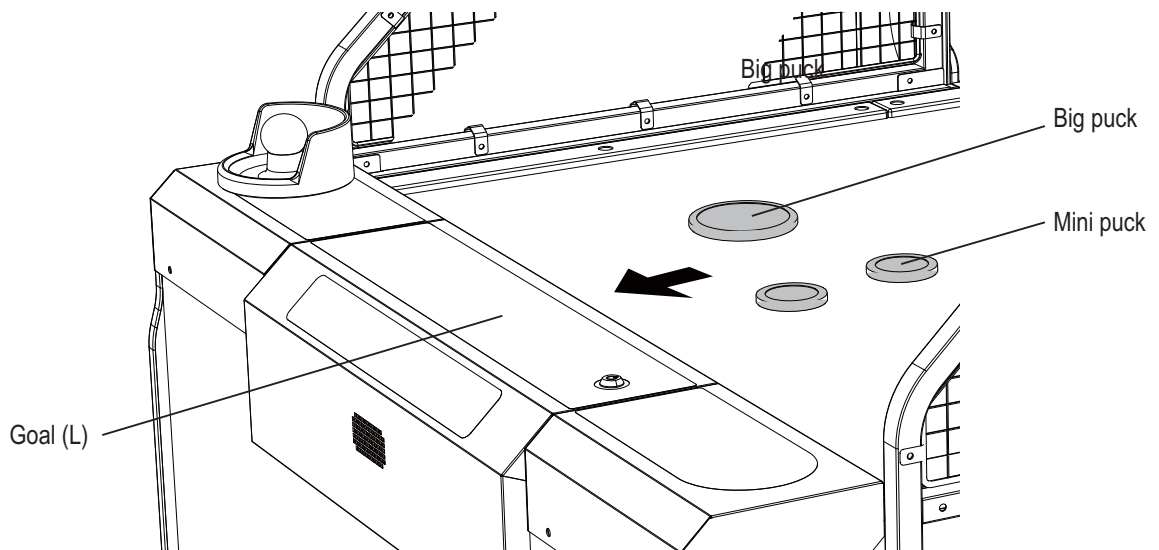

NOTICE

- Put the pucks into the goal (L) one to three pucks at a time. If many pucks are put into the goal at once, the pucks may become jammed inside the machine and prevent normal operation.
- Do not put 3 or more big pucks or a total of 160 or more mini pucks of any color into the machine. Doing so may cause a malfunction.

1

2

3

4

5

6

7

8A

8B

9

10

11

12

Assembly

Test Mode

Troubleshooting

- Must be performed by a technician -

8A-3 Connecting the Power Cord and Ground

WARNING

Be sure to install the ground wire. Failure to install the ground wire may result in electric shock in the event of electrical leakage.

- 1** Insert the socket side of the power cord into the power supply input socket of the cordbox assembly.

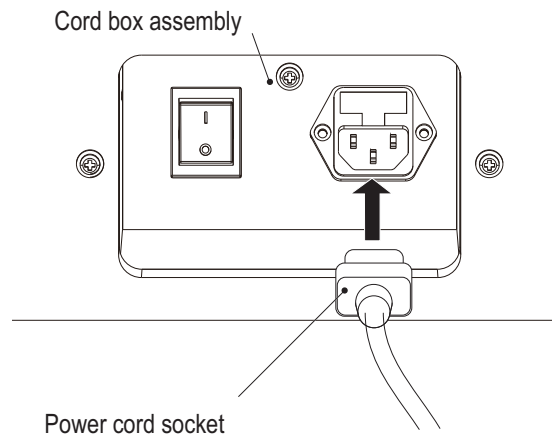

- 2** Insert the power cord plug into an outlet.

8A-4 Checks after Installation

After installation is complete, test each item in the Test mode, and set the necessary items in the Setting mode. (See "7-8 Test Mode" on page 41 and "7-9 Setting Mode" on page 49.)



After installation is complete, be sure to perform the puck supply operation to add pucks into the machine. (See "7-8-5 Solenoid ON/OFF Test and Sensor Check" on page 46.) (See "7-8-6 S Hopper Motor ON/OFF Test and Sensor Check" on page 47.)

8A-5 Opening and Closing Doors

8A-5-1 Opening and Closing the Front Doors

- 1 Remove the two Torx bolts (M5 x 35), and remove the front door on the side to be opened.

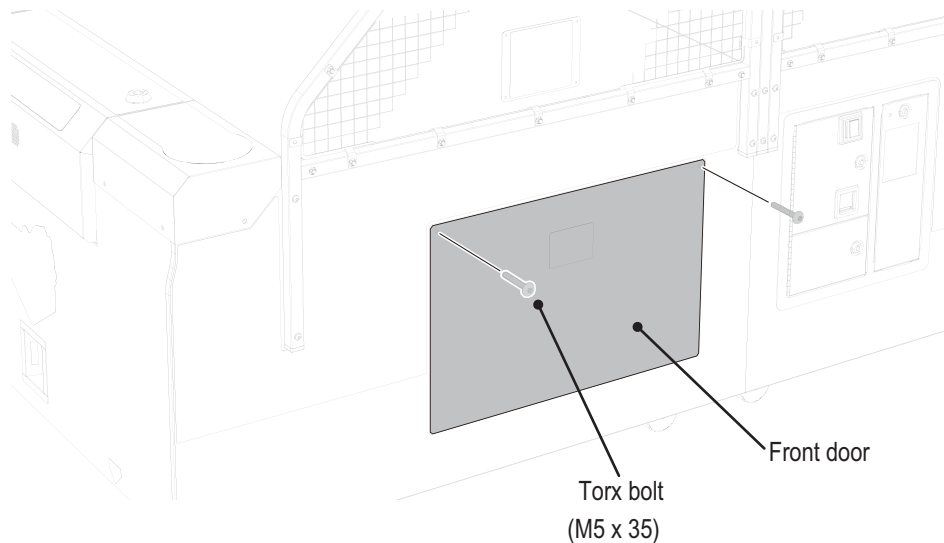

- 2 To install, perform the procedure in reverse.

8A-5-2 Opening and Closing the Service Doors L and R

- 1 Remove the two Torx bolts (M5 x 35).
- 2 Use the supplied service key to unlock, and remove the service door L or service door R.

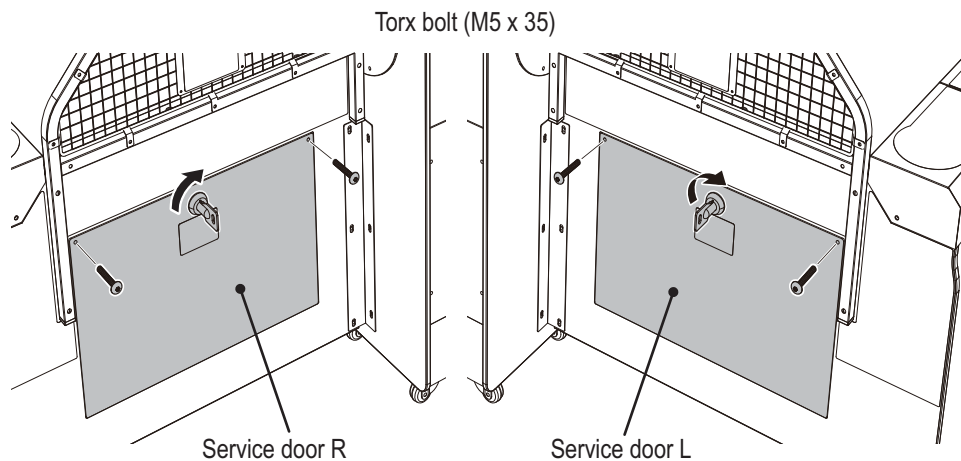

- 3 To install, perform the procedure in reverse.

1

2

3

4

5

6

7

8A

8B

9

10

11

12

Test Mode

Troubleshooting

- Must be performed by a technician -

8A-5-3 Opening and Closing the Rear Panel

- 1** Remove the four Torx bolts (M5 x 25).
- 2** Use the supplied service key to unlock, and remove the rear panel.

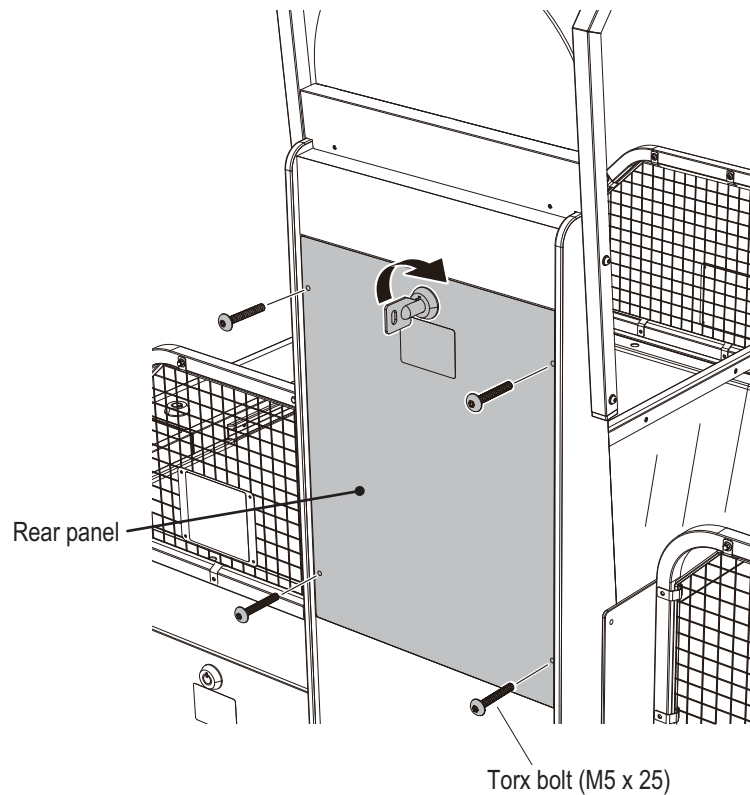

- 3** To install, perform the procedure in reverse.

8A-5-4 Opening and Closing the Service Door

- 1** Remove the three Torx bolts (M5 x 25), and remove the service door.

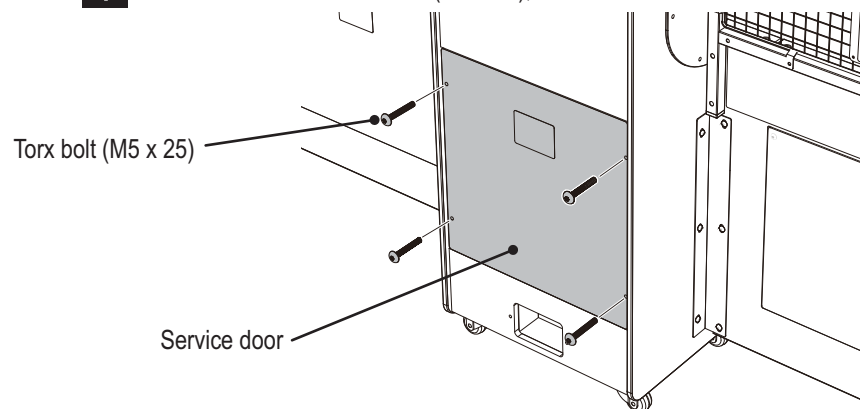

- 2** To install, perform the procedure in reverse.

- Must be performed by a technician -

8B. Service - Must be performed by a technician -

WARNING

To avoid electric shock, accidents or injuries to yourself or other people, or damage to the electronic circuits, be sure to turn off the power switch before performing service work (such as repairs or correcting malfunctions).

8B-1 Inspection and Service

WARNING

Perform periodic service. Failure to perform service may result in an accident.

8B-1-1 Inspection Items

Check the following inspection items periodically for any abnormalities.

- (1) Level Adjuster Inspection
 - Check that the level adjusters are fixed securely. (See “8A-2-2 Level Adjuster Adjustment” on page 77.)
- (2) Power Cord Plug Inspection
 - Check that the power cord is firmly inserted into the power outlet in the machine's cord box.
 - Clean any dust or other dirt from the connection parts.
 - Check for cracks or dirt on the power cord covering. If there is any abnormality on the power cord, be sure to replace it.
- (3) Screw Looseness Inspection

Check the following parts for loose screws. Fully retighten any loose screws.

 - Corner covers and goal covers (See “8A-2-1 (1) Assembling the Table, Goals and Corner Covers” on page 66.)
 - Net L and S, center guard, and side wall (See “8A-2-1 (2) Installing the Nets” on page 65.)
 - Goal bumpers (L) and (R), bumpers A,B,C

1

2

3

4

5

6

7

8A

8B

9

10

11

12

Opening and Closing Doors / Inspection and Service

Test Mode

Troubleshooting

- Must be performed by a technician -

8B-1-2 Cleaning the Puck Paths

(1) Cleaning the Insides of the Goal (L) and (R) Assemblies

The description below explains how to clean the (L) side. Follow the same procedure to clean the (R) side.



WARNING

To avoid electric shock, accidents or injuries to yourself or other people, or damage to the electronic circuits, be sure to turn off the power switch before starting work.



Do not use thinner, benzene, gasoline, alcohol or other organic solvents. This may degrade the materials.

- 1** Turn off the power switch. (See “7-6-1 Turning the Power Switch On” on page 39.)
- 2** Open the goal (L) assembly. (See “7-5-3 Opening and Closing the Goal (L) and (R) Assemblies” on page 38.)
- 3** Wipe away any dirt from the puck paths using a soft cloth moistened with water or a neutral cleanser diluted with water and then firmly wrung out.

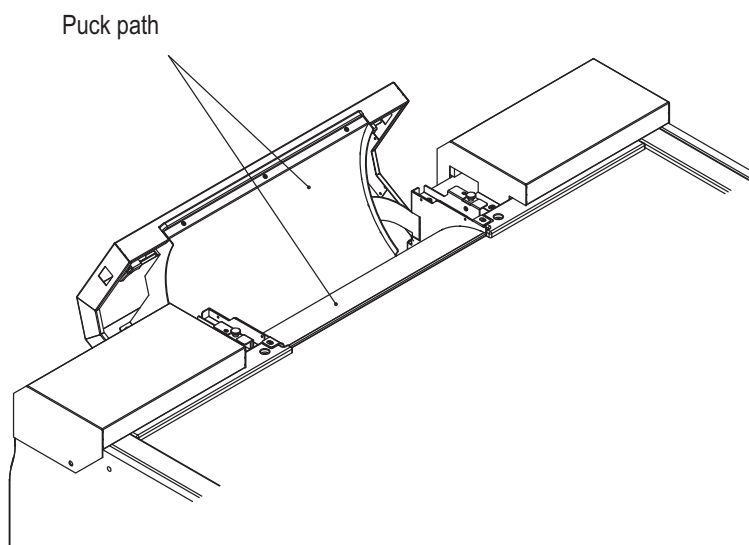

- 4** Wipe dry using a soft cloth so that no water or detergent remains, and then allow to dry completely.
- 5** To install, perform the procedure in reverse.

- Must be performed by a technician -

(2) Cleaning the Rail (L) and (R) Assemblies

The description below explains how to clean the (L) side. Follow the same procedure to clean the (R) side.

! WARNING

To avoid electric shock, accidents or injuries to yourself or other people, or damage to the electronic circuits, be sure to turn off the power switch before starting work.

NOTICE

Do not use thinner, benzene, gasoline, alcohol or other organic solvents. This may degrade the materials.

- 1** Turn off the power switch. (See "7-6-1 Turning the Power Switch On" on page 39.)
- 2** Open the service door L. (See "8A-5-2 Opening and Closing the Service Doors L and R" on page 87.)
- 3** Wipe away any dirt from the puck paths using a soft cloth moistened with water or a neutral cleanser diluted with water and then firmly wrung out.
* Use a cotton swab to clean narrow parts.

Rail (L) assembly

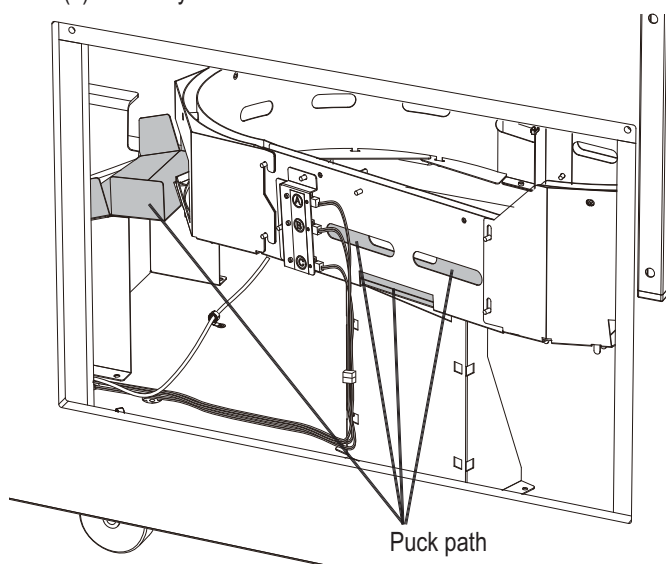

- 4** Wipe dry using a soft cloth so that no water or detergent remains, and then allow to dry completely.
- 5** To install, perform the procedure in reverse.

1

2

3

4

5

6

7

8A

8B

9

10

11

12

Inspection and Service

Test Mode

Troubleshooting

- Must be performed by a technician -

(3) Cleaning the Inside of the S Bucket (Hopper Assembly)

! WARNING

To avoid electric shock, accidents or injuries to yourself or other people, or damage to the electronic circuits, be sure to turn off the power switch before starting work.

NOTICE

Do not perform the following operations. Doing so may cause pucks to jam or other malfunctions.

- Rotating the S hopper disk in the counter-clockwise direction as viewed from above.

Do not use thinner, benzene, gasoline, alcohol or other organic solvents. This may degrade the materials.

- 1** Turn off the power switch. (See "7-6-1 Turning the Power Switch On" on page 39.)
- 2** Remove the side tower assembly. (See "8B-4-4 (1) Removing and Installing the Side Tower Assembly" on page 125.)
- 3** Remove any pucks from inside the S bucket.

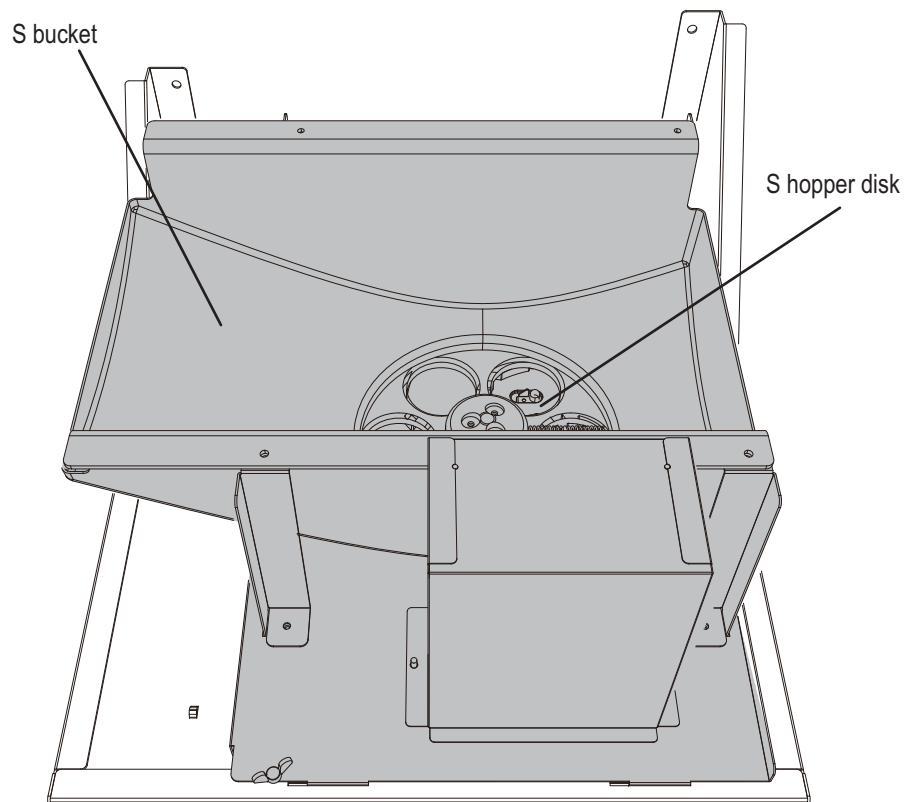

- 4** Wipe away any dirt from the puck paths using a soft cloth moistened with water or a neutral cleanser diluted with water and then firmly wrung out.
* Use a cotton swab to clean narrow parts.
- 5** Wipe dry using a soft cloth so that no water or detergent remains, and then allow to dry completely.
- 6** To install, perform the procedure in reverse.

- Must be performed by a technician -

(4) Cleaning the S Hopper Disk and S Hopper Bottom (Hopper Assembly)

! WARNING

To avoid electric shock, accidents or injuries to yourself or other people, or damage to the electronic circuits, be sure to turn off the power switch before starting work.

NOTICE

Do not perform the following operations. Doing so may cause pucks to jam or other malfunctions.

- Rotating the S hopper disk in the counter-clockwise direction as viewed from above.

Do not use thinner, benzene, gasoline, alcohol or other organic solvents. This may degrade the materials.

- 1 Turn off the power switch. (See "7-6-1 Turning the Power Switch On" on page 39.)
- 2 Remove the side tower assembly. (See "8B-4-4 (1) Removing and Installing the Side Tower Assembly" on page 125.)
- 3 Remove any pucks from inside the S bucket.
- 4 Remove the wing bolt (M4 x 10), slide the S hopper cover toward the outside, and remove it.

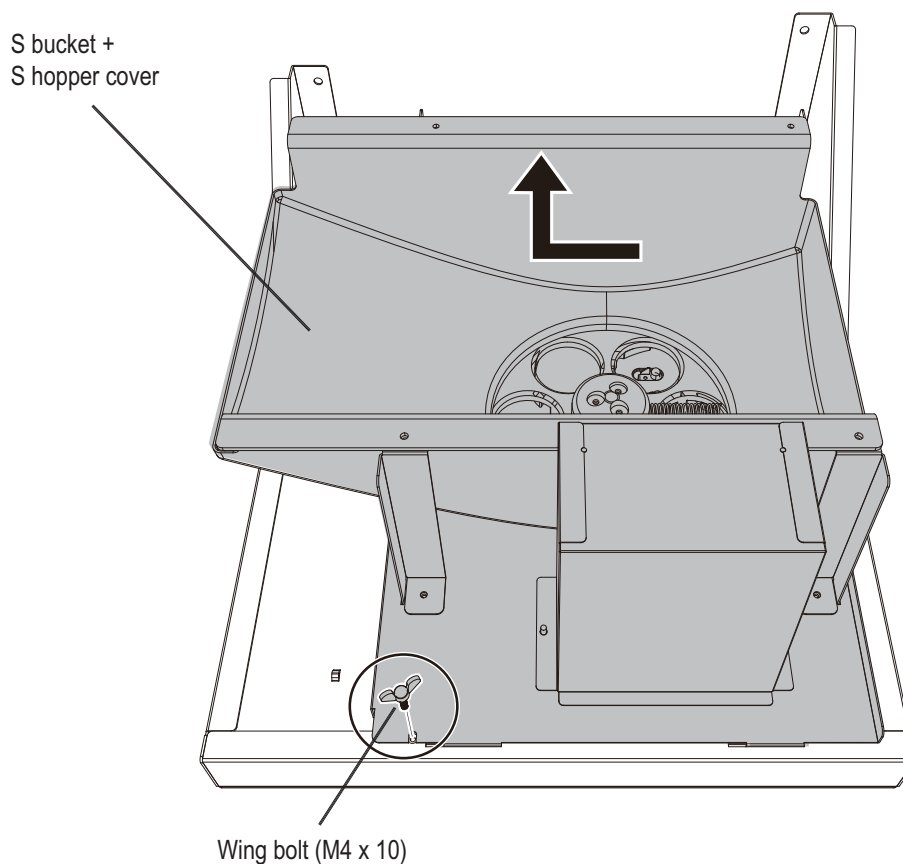

1

2

3

4

5

6

7

8A

8B

9

10

11

12

Inspection and Service

Test Mode

Troubleshooting

8B. Service

- Must be performed by a technician -

- 5** Disconnect the two connectors.
- 6** Loosen the four pan head screws (with flat and spring washers) (M4 x 8), and remove the S hopper motor bracket.

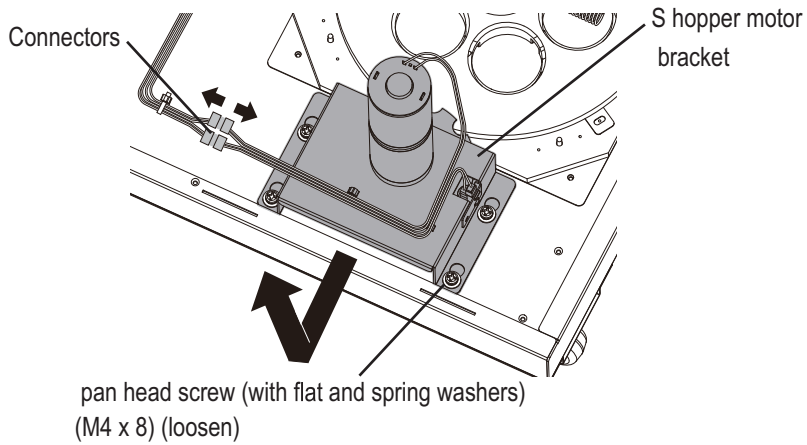

- 7** Remove the three pan head screws (with flat and spring washers) (M4 x 10), and remove the disk top.

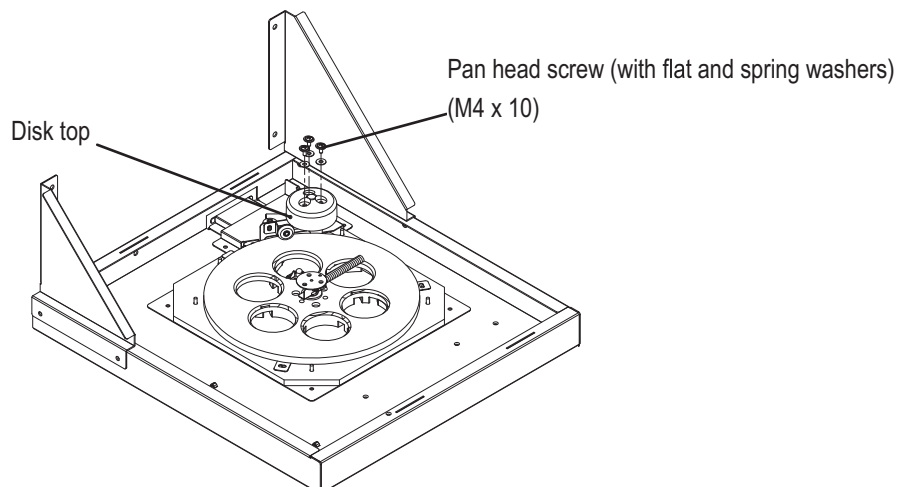

- 8** Remove the pan head screw (with flat and spring washers) (M4 x 8), and remove the hopper spring base.

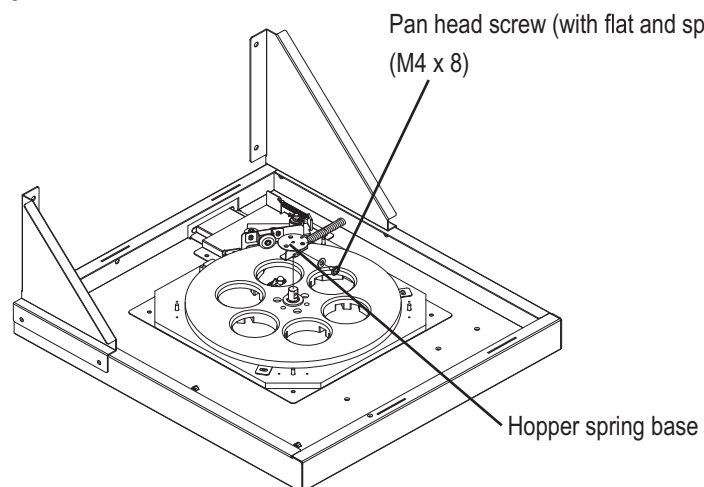

- Must be performed by a technician -

- 9** Remove the two pan head screws (with flat and spring washers) (M4 x 8), and remove the disk retainer bracket.

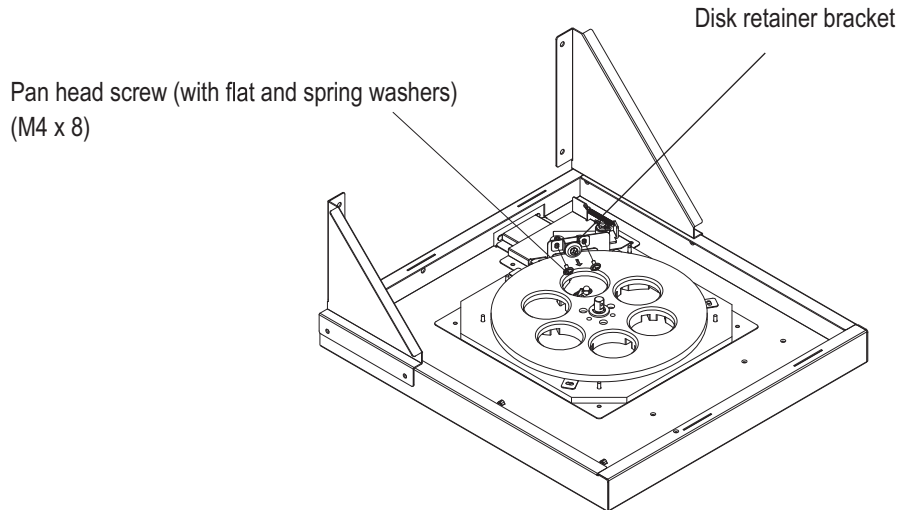

- 10** Remove the E-ring (nominal diameter: 10), and remove the flat washer (M12) and the S hopper disk.

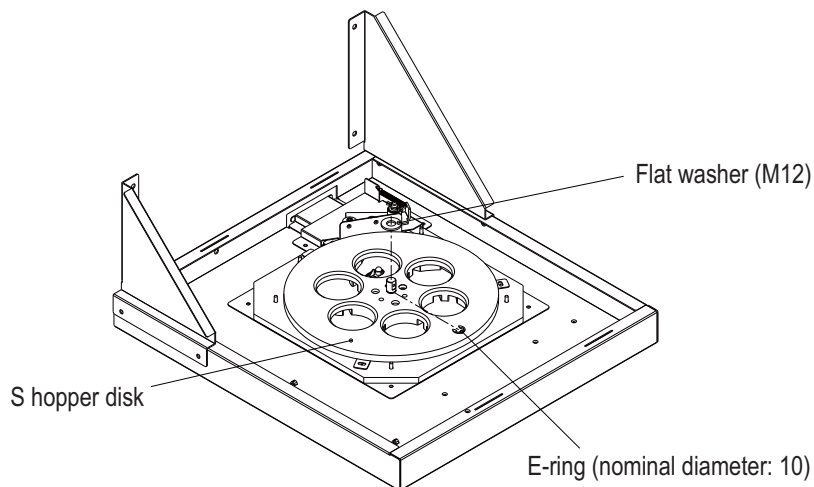

- 11** Wipe away any dirt from the puck paths using a soft cloth moistened with water or a neutral cleanser diluted with water and then firmly wrung out.
- 12** Wipe dry using a soft cloth so that no water or detergent remains, and then allow to dry completely.
- 13** To install, perform the procedure in reverse.

NOTICE

- When installing, press the hopper motor bracket toward the hopper disk so that the hopper gear and hopper disk teeth mesh properly.

1

2

3

4

5

6

7

8A

8B

9

10

11

12

Inspection and Service

Test Mode

Troubleshooting

- Must be performed by a technician -

(5) Cleaning the Slider Assembly

! WARNING

To avoid electric shock, accidents or injuries to yourself or other people, or damage to the electronic circuits, be sure to turn off the power switch before starting work.

NOTICE

Do not use thinner, benzene, gasoline, alcohol or other organic solvents. This may degrade the materials.

- 1** Turn off the power switch. (See "7-6-1 Turning the Power Switch On" on page 39.)
- 2** Remove the three Torx bolts (M4 x 12), and remove the cover panel retainer.
- 3** Remove the five Torx bolts (BLACK) (M4 x 12), and remove the cover panel.

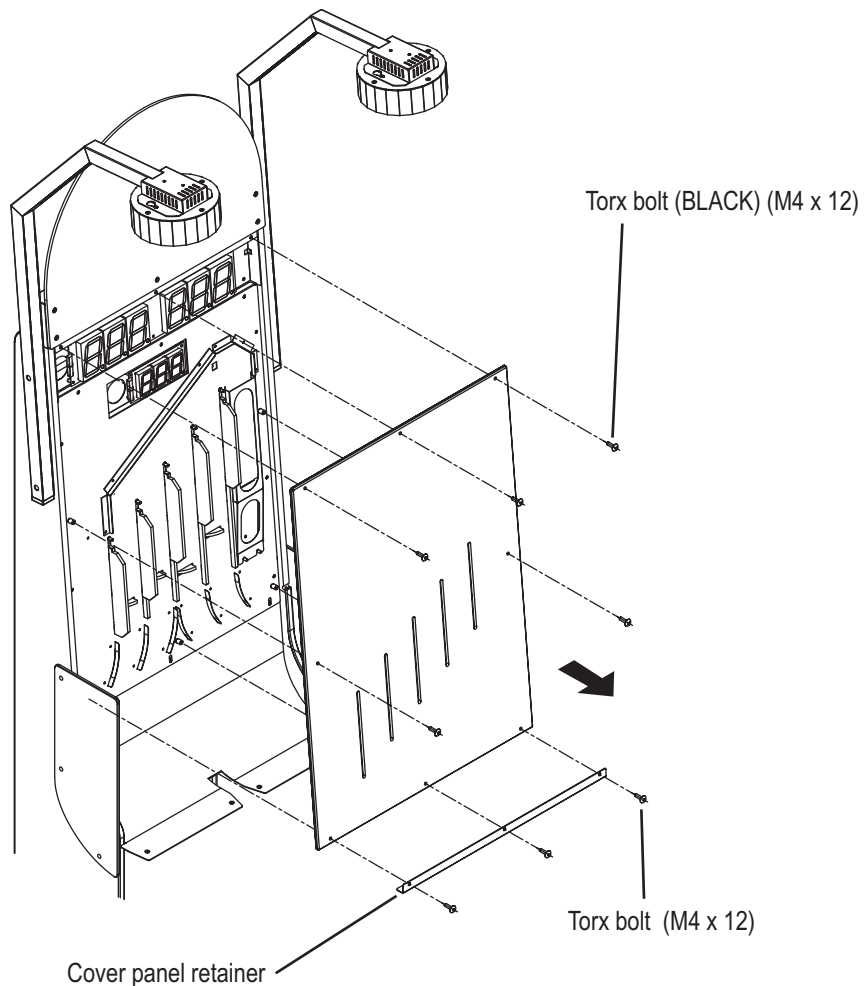

- Must be performed by a technician -

- 4 Wipe away any dirt from the puck paths using a soft cloth moistened with water or a neutral cleanser diluted with water and then firmly wrung out.
- 5 Wipe dry using a soft cloth so that no water or detergent remains, and then allow to dry completely.
- 6 To install, perform the procedure in reverse.

- 1
- 2
- 3
- 4
- 5
- 6
- 7
- 8A
- 8B**
- 9
- 10
- 11
- 12

Inspection and Service

Test Mode

Troubleshooting

- Must be performed by a technician -

8B-1-3 Removing Jammed Pucks



- Check that pucks are not damaged or deformed before putting them back into the machine. Otherwise, the pucks may jam again.

(1) Inside the Goal (L) or (R) Assembly

The description below explains how to remove jammed pucks from the (L) side. Follow the same procedure to remove jammed pucks from the (R) side.



- To avoid electric shock, accidents or injuries to yourself or other people, or damage to the electronic circuits, be sure to turn off the power switch before starting work.

- 1 Turn off the power switch. (See "7-6-1 Turning the Power Switch On" on page 39.)
- 2 Open the goal (L) assembly. (See "7-5-3 Opening and Closing the Goal (L) and (R) Assemblies" on page 38.)
- 3 Remove the jammed puck.
- 4 To install, perform the procedure in reverse.

(2) In case of the rail (L)/(R) assembly

The description below explains how remove jammed pucks from the (L) side. Follow the same procedure to remove jammed pucks from the (R) side.



- To avoid electric shock, accidents or injuries to yourself or other people, or damage to the electronic circuits, be sure to turn off the power switch before starting work.

- 1 Turn off the power switch. (See "7-6-1 Turning the Power Switch On" on page 39.)
- 2 Remove the service door L. (See "8A-5-2 Opening and Closing the Service Doors L and R" on page 87.)
- 3 Remove the jammed puck.
- 4 To install, perform the procedure in reverse.

- Must be performed by a technician -

(3) Inside the S Bucket (Hopper Assembly)**! WARNING**

- To avoid electric shock, accidents or injuries to yourself or other people, or damage to the electronic circuits, be sure to turn off the power switch before starting work.

- 1** Turn off the power switch. (See “7-6-1 Turning the Power Switch On” on page 39.)
- 2** Remove the side tower assembly. (See “8B-4-4 (1) Removing and Installing the Side Tower Assembly” on page 125.)
- 3** Remove any pucks from inside the S bucket, and then remove the jammed puck.
- 4** To install, perform the procedure in reverse.

(4) Inside the S Hopper Disk or S Hopper Bottom (Hopper Assembly)

The description below explains how to remove jammed pucks from the S hopper disk. Follow the same procedure to remove jammed pucks from the L hopper disk.

! WARNING

- To avoid electric shock, accidents or injuries to yourself or other people, or damage to the electronic circuits, be sure to turn off the power switch before starting work.

NOTICE

Do not perform the following operations. Doing so may cause pucks to jam or other malfunctions.

- Rotating the S hopper disk in the counter-clockwise direction as viewed from above.

- 1** Turn off the power switch. (See “7-6-1 Turning the Power Switch On” on page 39.)
- 2** Remove the side tower assembly. (See “8B-4-4 (1) Removing and Installing the Side Tower Assembly” on page 125.)
- 3** Remove the S hopper disk. (See steps **3** - **10** of “8B-1-2 (4) Cleaning the Hopper Disks and Hopper Bottoms (Hopper Assembly)” on page 93.)
- 4** Remove the jammed puck.
- 5** To install, perform the procedure in reverse.

1

2

3

4

5

6

7

8A

8B

9

10

11

12

Inspection and Service

Test Mode

Troubleshooting

- Must be performed by a technician -

(5) In case of S Escalator Assembly

 **WARNING**

● To avoid electric shock, accidents or injuries to yourself or other people, or damage to the electronic circuits, be sure to turn off the power switch before starting work.

- 1** Turn off the power switch. (See “7-6-1 Turning the Power Switch On” on page 39.)
- 2** Remove the cover panel. (See steps **2** - **3** of “8B-1-2 (5) Cleaning the Slider Assembly” on page 96.)
- 3** Remove the jammed puck
- 4** To install, perform the procedure in reverse

- Must be performed by a technician -

(6) In case of the Slider Assembly

 **WARNING**

- To avoid electric shock, accidents or injuries to yourself or other people, or damage to the electronic circuits, be sure to turn off the power switch before starting work.

- 1** Turn off the power switch. (See "7-6-1 Turning the Power Switch On" on page 39.)
- 2** Remove the cover panel. (See steps **2** - **3** of "8B-1-2 (5) Cleaning the Slider Assembly" on page 96.)
- 3** Remove the jammed puck.
- 4** To install, perform the procedure in reverse.

1

2

3

4

5

6

7

8A

8B

9

10

11

12

Inspection and Service

Test Mode

Troubleshooting

- Must be performed by a technician -

8B-1-4 Adding Big Puck

The description below explains how to add the (L) side. Follow the same procedure to add the (R) side.

WARNING

- To avoid electric shock, accidents or injuries to yourself or other people, or damage to the electronic circuits, be sure to turn off the power switch before starting work.

- 1** Turn off the power switch. (See “7-6-1 Turning the Power Switch On” on page 39.)
- 2** Open the service door L. (See “8A-5-2 Opening and Closing the Service Doors L and R” on page 87.)
- 3** Count the number of big pucks in the big puck stock .

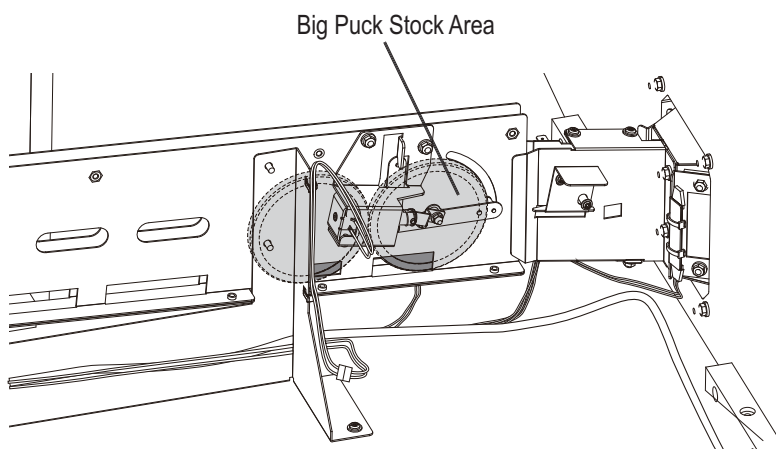

- 4** Add big pucks so that there are 2 big pucks in the big puck stock.
- 5** To install, perform the procedure in reverse.

NOTICE

- Don't put the big pucks into the stock (L) and stock (R) over three pucks each.
- If many pucks are put into the goal at once, the pucks may become jammed inside the machine and prevent normal operation.
- Be sure to check the number of big pucks in the stock area.

- Must be performed by a technician -

8B-2 Error Display (for Technicians)

8B-2-1 Display when an Error Occurs

When an error occurs, "Err" is displayed in the left side score LED, and the error number is displayed in the right side score LED. The same error number is displayed as a binary value in the time LED.

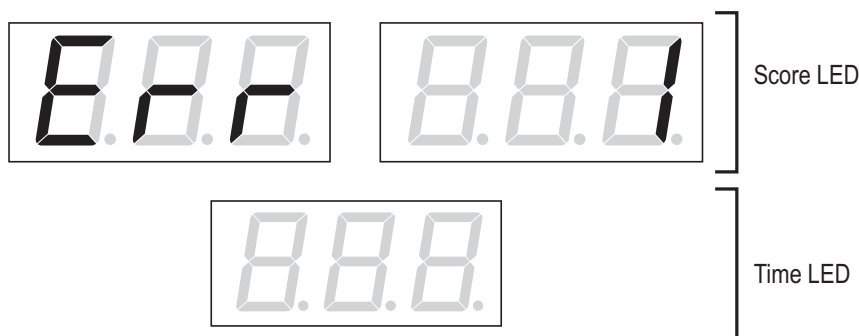

Signboard display (when error number = 1)



- Before checking for a malfunction, first make sure that all the connectors are connected securely.

8B-2-2 Resolving Errors

Error number	Error name	Cause	Action	Reference page
1	Coin switch error	• A coin selector malfunction.	• Replace the coin selector.	—
		• Main PC board malfunction.	• Replace the main PC board.	Page 126
3	Bill validator error	• A bill Validator malfunction.	• Replace the bill Validator.	—
		• Main PC board malfunction.	• Replace the main PC board.	
4	Service switch error	• Service button malfunction.	• Contact your distributor.	—
		• Main PC board malfunction.	• Replace the main PC board.	Page 126

8B. Service

- Must be performed by a technician -

Error number	Error name	Cause	Action	Reference page
11	Goal (L) sensor error	• A puck or foreign object is jammed inside the L side goal.	• Remove the jammed puck or foreign object from inside the goal (L).	Page 98
		• A puck or foreign object is jammed inside the corner rail (L).	• Remove the jammed puck or foreign object from inside the goal (L).	Page 98
		• The goal (L) sensor is dirty.	• Clean the inside of the goal (L) sensor.	Page 118
		• Goal (L) sensor malfunction.	• Replace the goal (L) sensor.	Page 118
12	Goal (R) sensor error	• A puck or foreign object is jammed inside the R side goal.	• Remove the jammed puck or foreign object from inside the goal (R).	Page 98
		• A puck or foreign object is jammed inside the corner rail (R).	• Remove the jammed puck or foreign object from inside the goal (R).	Page 98
		• The goal (R) sensor is dirty.	• Clean the inside of the goal (R) sensor.	Page 118
		• Goal (R) sensor malfunction.	• Replace the goal (R) sensor.	Page 118
13	Rail (L) jamming error (sensor C)	• A puck is jammed inside the rail (L).	• Remove the jammed puck or foreign object.	Page 98
		• Rail (L) sensor (C) is dirty.	• Clean the inside of the Rail (L) sensor (C).	Page 121
		• Rail (L) sensor (C) malfunction.	• Replace Rail (L) sensor (C).	Page 121
14	Rail (R) jamming error (sensor C)	• A puck is jammed inside the rail (R).	• Remove the jammed puck or foreign object.	Page 98
		• Rail (R) sensor (C) is dirty.	• Clean the inside of the Rail (R) sensor (C).	Page 121
		• Rail (R) sensor (C) malfunction.	• Replace Rail (L) sensor (C).	Page 121
15	Rail (L) jamming error (sensor A)	• A puck is jammed inside the rail (L).	• Remove the jammed puck or foreign object.	Page 98
		• Rail (L) sensor (A) is dirty.	• Clean the inside of the Rail (L) sensor (A).	Page 121
		• Rail (L) sensor (A) malfunction.	• Replace Rail (L) sensor (A).	Page 121

- Must be performed by a technician -

Error number	Error name	Cause	Action	Reference page
16	Rail (R) jamming error (sensor A)	• A puck is jammed inside the rail (R).	• Remove the jammed puck or foreign object.	Page 98
		• Rail (R) sensor (A) is dirty.	• Clean the inside of the Rail (R) sensor (A)	Page 121
		• Rail (R) sensor (A) malfunction.	• Replace Rail (R) sensor (A).	Page 121
17	Rail (L) jamming error (sensor B)	• A puck is jammed inside the rail (L).	• Remove the jammed puck or foreign object.	Page 98
		• Rail (L) sensor (B) is dirty.	• Clean the inside of the Rail (L) sensor (B).	Page 121
		• Rail (L) sensor (B) malfunction.	• Replace Rail (L) sensor (B).	Page 121
18	Rail (R) jamming error (sensor B)	• A puck is jammed inside the rail (R).	• Remove the jammed puck or foreign object.	Page 98
		• Rail (R) sensor (B) is dirty.	• Clean the inside of the Rail (R) sensor (B).	Page 121
		• Rail (R) sensor (B) malfunction.	• Replace Rail (R) sensor (B)	Page 121
19	Big puck empty error	• Both stockers of a Big puck (L,R) are emptied.	• Add big pucks.	Page 102
21	Rail (L) jamming error (1st corner)	• A puck or foreign object is jammed inside the Rail (L) of the goal.	• Remove the jammed puck or foreign object.	Page 98
22	Rail (R) jamming error (1st corner)	• A puck or foreign object is jammed inside the Rail (R) of the goal.	• Remove the jammed puck or foreign object.	Page 98

1

2

3

4

5

6

7

8A

8B

9

10

11

12

Error Display (for Technicians)

Test Mode

Troubleshooting

8B. Service

- Must be performed by a technician -

Error number	Error name	Cause	Action	Reference page
23	L outlet sensor (L) error	<ul style="list-style-type: none"> A puck or foreign object is jammed inside the L outlet Assembly 	<ul style="list-style-type: none"> Remove the jammed puck or foreign object from the L outlet Assembly 	Page 102
		<ul style="list-style-type: none"> L stopper (L) sensor is dirty. 	<ul style="list-style-type: none"> Clean the inside of the L stopper (L) sensor. 	Page 123
		<ul style="list-style-type: none"> L stopper (L) sensor malfunction. 	<ul style="list-style-type: none"> Replace L stopper (L) sensor. 	Page 123
		<ul style="list-style-type: none"> L outlet (L) sensor is dirty. 	<ul style="list-style-type: none"> Clean the inside of the L outlet sensor. 	Page 142
		<ul style="list-style-type: none"> L outlet (L) sensor malfunction. 	<ul style="list-style-type: none"> Replace L outlet (L) sensor. 	Page 142
		<ul style="list-style-type: none"> L stopper solenoid(L) malfunction. 	<ul style="list-style-type: none"> Replace L stopper (L) solenoid. 	Page 124
24	L outlet sensor (R) error	<ul style="list-style-type: none"> A puck or foreign object is jammed inside the L outlet Assembly 	<ul style="list-style-type: none"> Remove the jammed puck or foreign object from the L outlet Assembly 	Page 102
		<ul style="list-style-type: none"> L stopper (R) sensor is dirty. 	<ul style="list-style-type: none"> Clean the inside of the L stopper (R) sensor. 	Page 123
		<ul style="list-style-type: none"> L stopper (R) sensor malfunction. 	<ul style="list-style-type: none"> Replace L stopper (R) sensor. 	Page 123
		<ul style="list-style-type: none"> L outlet (R) sensor is dirty. 	<ul style="list-style-type: none"> Clean the inside of the L outlet sensor. 	Page 142
		<ul style="list-style-type: none"> L outlet (R) sensor malfunction. 	<ul style="list-style-type: none"> Replace L outlet (R) sensor. 	Page 142
		<ul style="list-style-type: none"> L stopper solenoid(R) malfunction. 	<ul style="list-style-type: none"> Replace L stopper (R) solenoid. 	Page 124
31	Coin counter error	<ul style="list-style-type: none"> A counter harness isn't connected. 	<ul style="list-style-type: none"> Connect the harness. 	—
32	Bill Validator counter error	<ul style="list-style-type: none"> A counter harness isn't connected.. 	<ul style="list-style-type: none"> Connect the harness. 	—
40	S hopper motor error	<ul style="list-style-type: none"> A mini puck is jammed inside S hopper. 	<ul style="list-style-type: none"> Remove the jammed puck. 	Page 99
		<ul style="list-style-type: none"> A foreign object other than a mini puck has entered S hopper. 	<ul style="list-style-type: none"> Remove the foreign object from inside the hopper. 	Page 99
		<ul style="list-style-type: none"> S hopper sensor malfunction. 	<ul style="list-style-type: none"> Replace the S hopper sensor. 	Page 134
		<ul style="list-style-type: none"> S hopper motor malfunction. 	<ul style="list-style-type: none"> Replace S hopper motor. 	Page 131

- Must be performed by a technician -

Error number	Error name	Cause	Action	Reference page
41	S hopper idling error	• There are no mini pucks inside S hopper.	• Add mini pucks to S hopper.	Page 81
		• A mini puck is standing on edge inside S hopper.	• Remove all of the pucks from S hopper, and then put the pucks back into S hopper correctly..	Page 99
		• A mini puck is jammed inside S hopper.	• Remove the jammed puck.	Page 99
		• S escalator outlet sensor malfunction.	• Replace escalator outlet sensor.	Page 141
42	S escalator outlet sensor error	• S escalator outlet sensor is dirty.	• Clean the inside of the S escalator sensor.	Page 141
		• S escalator outlet sensor malfunction.	• Replace S escalator outlet sensor.	Page 141
43	S stopper solenoid error (sensor is a condition of off.)	• S stopper solenoid malfunction.	• Replace S stopper solenoid.	Page 135
		• S stopper sensor is dirty.	• Clean the inside of the S stopper sensor.	Page 136
		• S stopper sensor malfunction.	• Replace S stopper sensor.	Page 136
44	S stopper solenoid error (sensor is a condition of on.)	• S stopper solenoid malfunction.	• Replace S stopper solenoid.	Page 135
		• S stopper sensor is dirty.	• Clean the inside of the S stopper sensor.	Page 136
		• S stopper sensor malfunction.	• Replace S stopper sensor.	Page 136
9	Main PC Board error	• Main PC board malfunction.	• Replace the main PC board.	—

1

2

3

4

5

6

7

8A

8B

9

10

11

12

Error Display (for Technicians)

Test Mode

Troubleshooting

- Must be performed by a technician -

8B-3 Troubleshooting

WARNING

- To avoid electric shock, accidents or injuries to yourself or other people, or damage to the electronic circuits, be sure to turn off the power switch before starting work.
- If the problem is not described in “8B-3 Troubleshooting” or the problem persists despite taking the appropriate action, turn off the power switch immediately to stop operation, and contact your distributor. Continuing operations may result in an accident.

NOTICE

- Before checking for a malfunction, first make sure that all the connectors are connected securely.
- Never perform a conductivity check of the boards with a tester or any other tool. The IC may be damaged by the internal voltage of the tester.
- When sending parts for repair, be sure to pack them properly. Particularly when sending the main PC board, wrap the part in sponge or air bubble wrapping before packing it in a cardboard box to make sure that the part is not exposed to external force.

- Must be performed by a technician -

8B-3-1 Overall

Symptom	Main cause	Action	Reference page
The machine does not start even when the power switch is turned on.	The power cord is disconnected from the outlet or the machine, or is not connected securely.	Connect the power cord correctly and securely. Turn on the power switch again.	Page 86
	The PCB base is not installed correctly.	Install the PCB base.	Page 126
	The fuse has blow.	Replace with a fuse of the specified capacity. If the fuse blows often, there is a problem with the machine. Contact your distributor.	—
	Main PC board malfunction.	Replace the main PC board.	Page 126
	Switching regulator malfunction.	Replace the switching regulator.	Page 128
Operation is not stable.	The power supply voltage is not within the range of AC 110 V to 130 V (or 210 V to 230 V).	Disconnect any high-capacity devices (such as an air conditioner or large machine) from the same line to secure the specified power supply voltage.	—

8B-3-2 Table top assembly

Symptom	Main cause	Action	Reference page
The pucks do not slide.	The machine is in Attract (standby) mode.	When the game starts, the blower fan operates so that the pucks slide.	Page 40
	The inside of the playing field.	Clean the playing field.	Page 61
	A puck is deformed.	Replace the deformed puck with a spare puck.	Page 85
	A puck is dirty.	Clean the puck.	Page 62
	The blower fan malfunction.	Replace the blower fan.	Page 116
	SSR malfunction.	Replace the SSR.	Page 130

1

2

3

4

5

6

7

8A

8B

9

10

11

12

Troubleshooting

Test Mode

Troubleshooting

- Must be performed by a technician -

8B-3-3 Goal (L) and (R) Assemblies

Symptom	Main cause	Action	Reference page
Pucks jam frequently.	Goal coin locks is not closed.	Use the service key and close the goal.	Page 38
	A deformed puck is being used.	Replace the deformed puck with a spare puck.	Page 85
	A puck is dirty.	Clean the puck.	Page 62
	A foreign object has entered the goal.	Remove the foreign object.	Page 90
	The inside of the goal is dirty.	Clean the inside of the goal.	Page 90
The goal LED does not light.	A goal LED malfunction.	Replace the goal LED board	Page 119
	Main PC board malfunction.	Replace the main PC board	Page 126
Sound is not output.	The volume setting is low.	Adjust the volume.	Page 48
	Main PC board malfunction.	Replace the main PC board.	Page 126

8B-3-4 Rail (L) and (R) Assemblies

Symptom	Main cause	Action	Reference page
Pucks jam frequently.	A deformed puck is being used.	Replace the deformed puck with a spare puck.	Page 85
	A puck is dirty.	Clean the puck.	Page 62
	A foreign object has entered the rail.	Remove the foreign object.	Page 98
	The inside of the rail is dirty.	Clean the inside of the rail.	Page 91

8B-3-5 Coin Assembly

Symptom	Main cause	Action	Reference page
The game does not start even when sufficient coins are inserted.	Coin selector malfunction.	Replace the coin selector.	—
	Main PC board malfunction.	Replace the main PC board.	Page 126

- Must be performed by a technician -

8B-3-6 S Hopper assembly

Symptom	Main cause	Action	Reference page
The hopper disk does not operate.	A foreign object has entered the hopper.	Remove the side tower assembly, and remove the foreign object from inside the hopper.	Page 99
	A puck is jammed inside the hopper.	Remove the side tower assembly, and remove all pucks from inside the hopper.	Page 99
	The hopper motor bracket is not installed correctly.	Install the hopper motor bracket correctly.	Page 131
	The hopper gear is not installed correctly.	Install the hopper gear correctly.	Page 131
	Hopper motor malfunction.	Replace the hopper motor.	Page 131
	Switching regulator (24V) malfunction.	Replace the switching regulator (24V).	Page 128
	Main PC board malfunction.	Replace the main PC board.	Page 126
The hopper disk operates, but pucks do not come out.	There are not enough pucks.	Add spare pucks to the hopper.	Page 85
	A puck is standing on edge inside the hopper.	Remove the side tower assembly, remove all pucks from inside the hopper, and then put the pucks back into the hopper correctly.	Page 99
	The hopper spring is not installed correctly.	Install the hopper spring correctly.	Page 93

1

2

3

4

5

6

7

8A

8B

9

10

11

12

Troubleshooting

Test Mode

Troubleshooting

8B. Service

- Must be performed by a technician -

8B-3-7 Slider Assembly

Symptom	Main cause	Action	Reference page
Mini pucks are not supplied during game play.	There are not enough pucks.	Add spare pucks to the hopper.	Page 85
	One or more deformed pucks is mixed into the pucks.	Remove any deformed pucks, and replace with spare pucks.	Page 98
	The stopper base is not installed correctly.	Install the stopper base correctly.	Page 135
	S stopper solenoid malfunction.	Replace the stopper solenoid.	Page 135
	Main PC board malfunction.	Replace the main PC board.	Page 126
	Switching regulator (12V) malfunction.	Replace the switching regulator (12V).	Page 128
mini pucks stack and become jammed.	The cover panel is not installed correctly.	Install the cover panel correctly.	Page 96
The time LED PC board does not light	Time LED PC board malfunction.	Replace the time LED PC board.	Page 137
	Main PC board malfunction.	Replace the main PC board.	Page 126
The score LED PC board does not light	Score LED PC board malfunction.	Replace the score LED PC board.	Page 138
	Main PC board malfunction.	Replace the main PC board.	Page 126
The S stocker LED does not light	Tape LED malfunction.	Replace the tape LED.	Page 139
	Main PC board malfunction.	Replace the main PC board.	Page 126

8B-3-8 S Escalator Assembly

Symptom	Main cause	Action	Reference page
Pucks remain inside the joint rail cover.	Escalator outlet sensor malfunction.	Replace the escalator outlet sensor.	Page 141

- Must be performed by a technician -

8B-3-9 L Outlet assembly

Symptom	Main cause	Action	Reference page
Big pucks are not supplied during game play.	There are not enough pucks.	Add spare pucks to the big puck stocker area.	Page 102
	Deformed pucks is mixed into the pucks.	Remove any deformed pucks, and replace with spare pucks.	Page 98
	The inside of the rail is dirty.	Clean the inside of the rail.	Page 91
	L stopper sensor malfunction.	Replace the L stopper sensor.	Page 123
	L outlet sensor malfunction.	Replace the L outlet sensor.	Page 142
The L stopper solenoid does not operate.	L stopper solenoid malfunction.	Replace the L stopper solenoid.	Page 124
	Main PC board malfunction.	Replace the main PC board.	Page 126

8B-3-10 Light assembly

Symptom	Main cause	Action	Reference page
The light LED PC board does not light.	A light LED malfunction.	Replace the light LED PC board.	Page 145
	Main PC board malfunction.	Replace the main PC board.	Page 126

1

2

3

4

5

6

7

8A

8B

9

10

11

12

Troubleshooting

Test Mode

Troubleshooting

- Must be performed by a technician -

8B-4 Removing, Installing and Replacing Assemblies and Parts

8B-4-1 Table

(1) Removing and Installing the Goal (L) and (R) Assemblies

The description below explains how to remove and install the L side. Follow the same procedure to remove and install the R side.

WARNING

- To avoid electric shock, accidents or injuries to yourself or other people, or damage to the electronic circuits, be sure to turn off the power switch before starting work.

CAUTION

- When lifting up the goal (L) or (R) assembly, be sure to perform the work with two or more people.

- 1** Turn off the power switch. (See “7-6-1 Turning the Power Switch On” on page 39.)
- 2** Open the goal (L) assembly. (See “7-5-3 Opening and Closing the Goal (L) and (R) Assemblies” on page 38.)
- 3** Disconnect the connector.

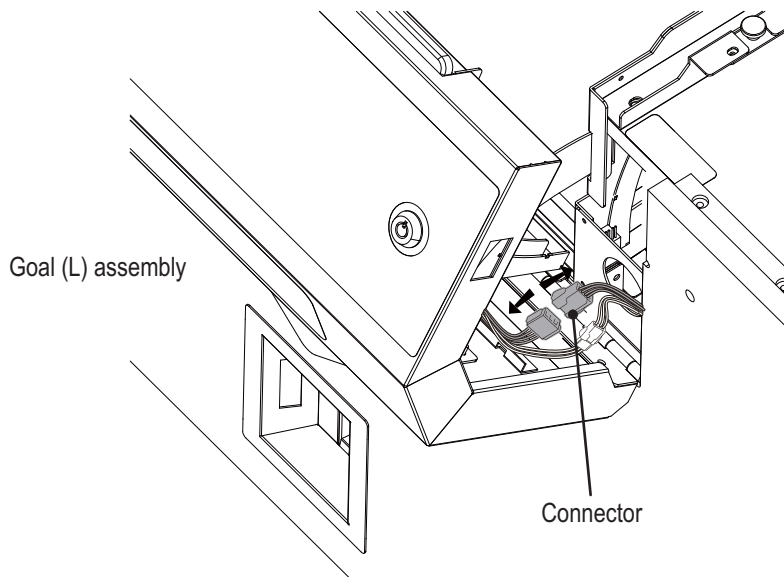

- Must be performed by a technician -

- 4** Remove the four Phillips hexagon socket head bolt (with flat and spring washers) (M6 x16) and two Phillips hexagon socket head bolt (with flat and spring washers) (M5 x 8) from the right and left of the goal (L) assembly.

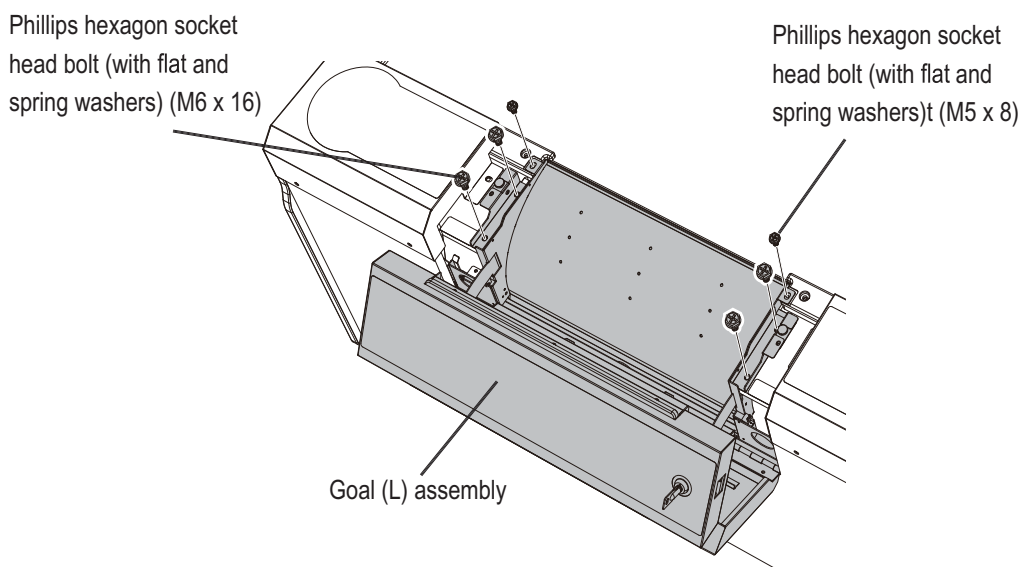

- When installing, be sure to use bolts of the specified length.
- When removing and installing, be careful not to pinch the harness and connectors.

- 5** Close the goal (L) assembly. (See “7-5-3 Opening and Closing the Goal (L) and (R) Assemblies” on page 38.)
- 6** Lift the goal (L) assembly straight up with two people, and remove it.

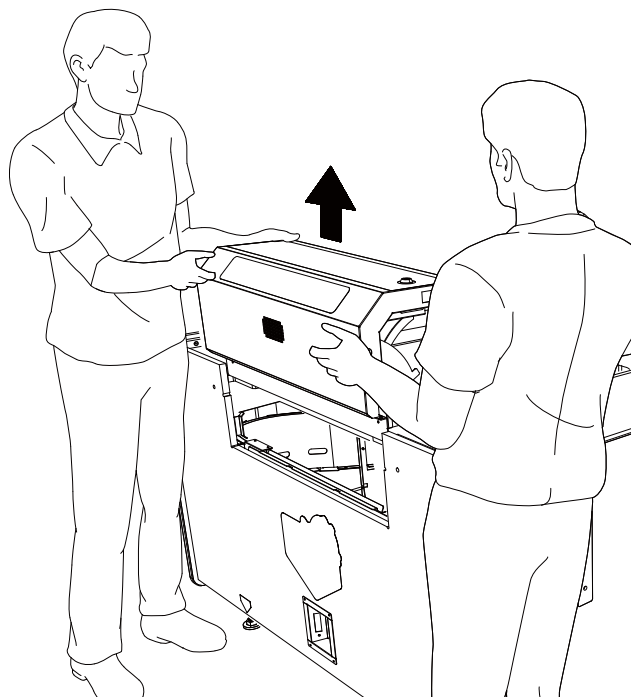

- 7** To install, perform the procedure in reverse.

1

2

3

4

5

6

7

8A

8B

9

10

11

12

Removing, Installing and Replacing Assemblies and Parts

Test Mode

Troubleshooting

- Must be performed by a technician -

(2) Replacing the Blower Fan

! WARNING

● To avoid electric shock, accidents or injuries to yourself or other people, or damage to the electronic circuits, be sure to turn off the power switch before starting work.

- 1** Turn off the power switch. (See "7-6-1 Turning the Power Switch On" on page 39.)
- 2** Open the front door. (See "8A-5-1 Opening and Closing the Front Doors" on page 87.)
- 3** Disconnect the connector.
- 4** Remove the four cap socket bolts(M5 x 30), the four springs (M5) and the four flat washers (M5).

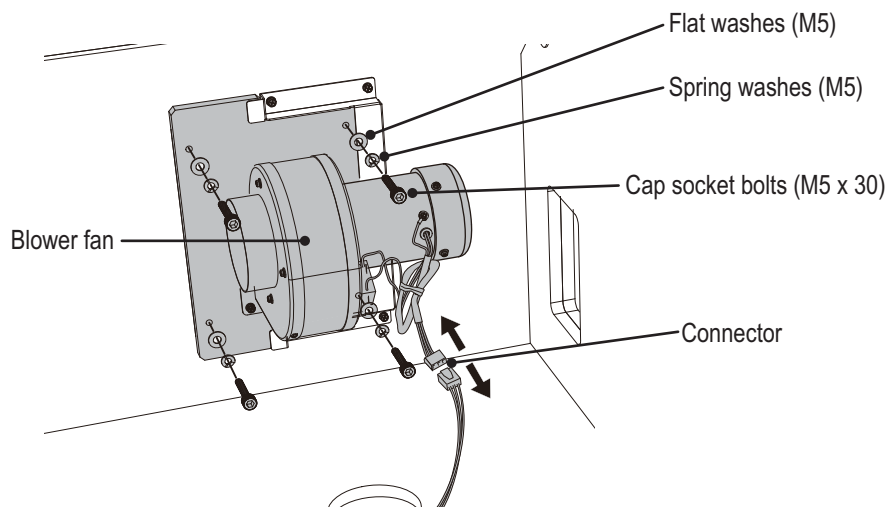

- 5** Slide the blower mounting plate toward the left side, and remove it.

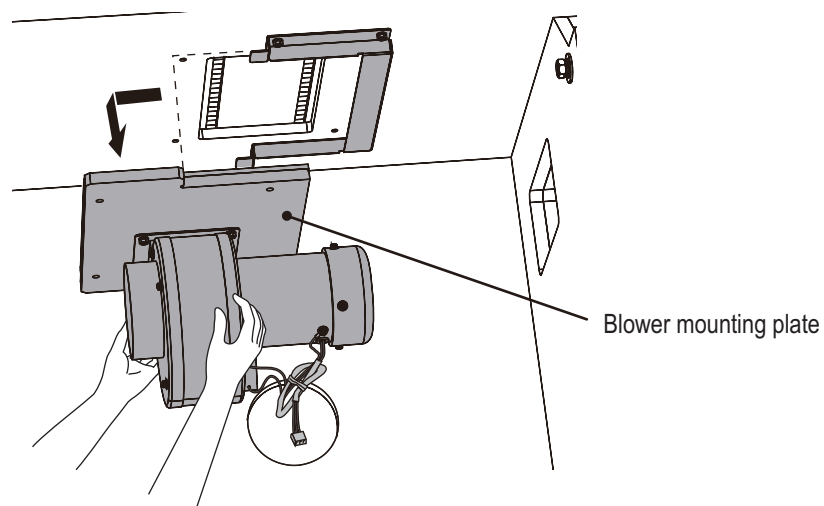

- Must be performed by a technician -

- 6** Remove the four Phillips hexagon socket head bolt (with flat and spring washers) (M5 x 15), and remove the blower fan from the blower fan mounting plate.

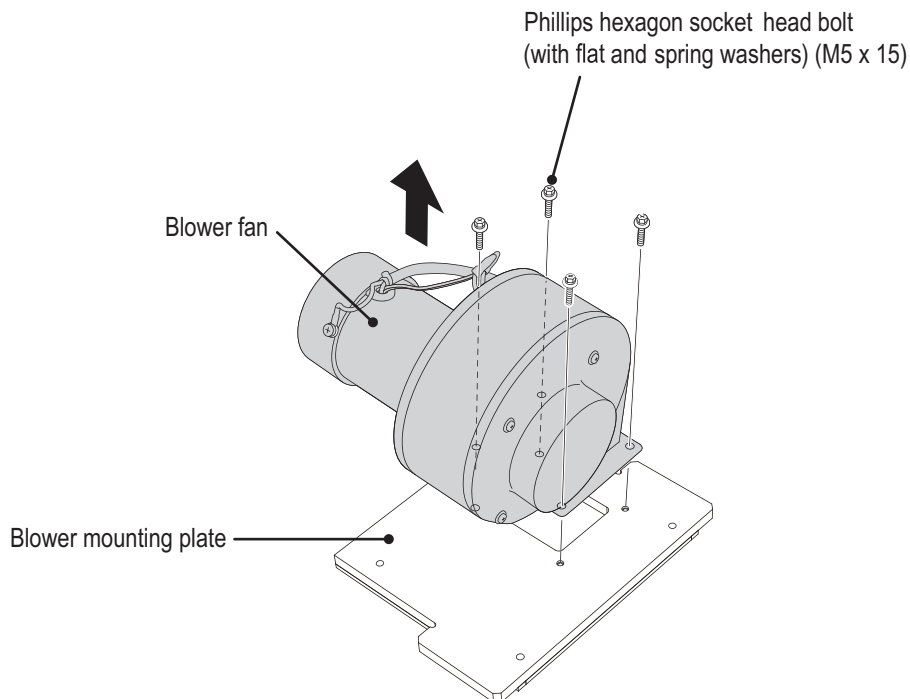

- 7** To install, perform the procedure in reverse.

1

2

3

4

5

6

7

8A

8B

9

10

11

12

Removing, Installing and Replacing Assemblies and Parts

Test Mode

Troubleshooting

- Must be performed by a technician -

8B-4-2 Goal (L) and (R) Assemblies

(1) Replacing the Goal (L) and (R) Sensors (Photosensor Side) and (Photo-emitter Side)

The description below explains how to replace the (L) side. Follow the same procedure for replacement of the (R) side.

WARNING

- To avoid electric shock, accidents or injuries to yourself or other people, or damage to the electronic circuits, be sure to turn off the power switch before starting work.

- 1** Turn off the power switch. (See “7-6-1 Turning the Power Switch On” on page 39.)
- 2** Open the goal (L) assembly. (See “7-5-3 Opening and Closing the Goal (L) and (R) Assemblies” on page 38.)
- 3** Remove the goal (L) assembly. (See “8B-4-1 (1) Removing and Installing the Goal (L) and (R) Assemblies” on page 114.)
- 4** Disconnect the two connectors of the goal (L) sensor (photosensor side) and (photo-emitter side).

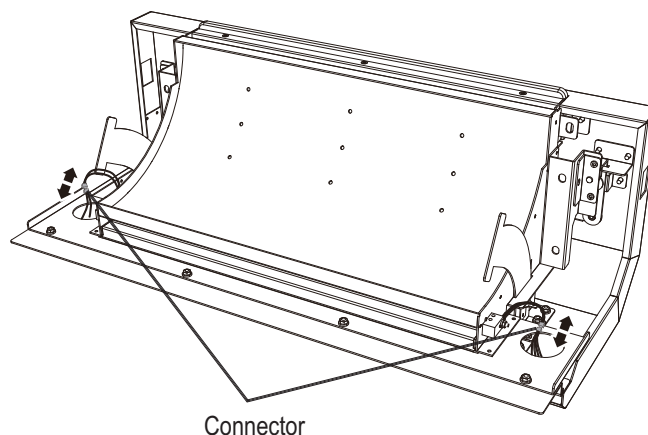

- Must be performed by a technician -

- 5** Remove the two Hex nuts with flange (M3), and remove the goal (L) sensor (photosensor side) and (photo-emitter side).

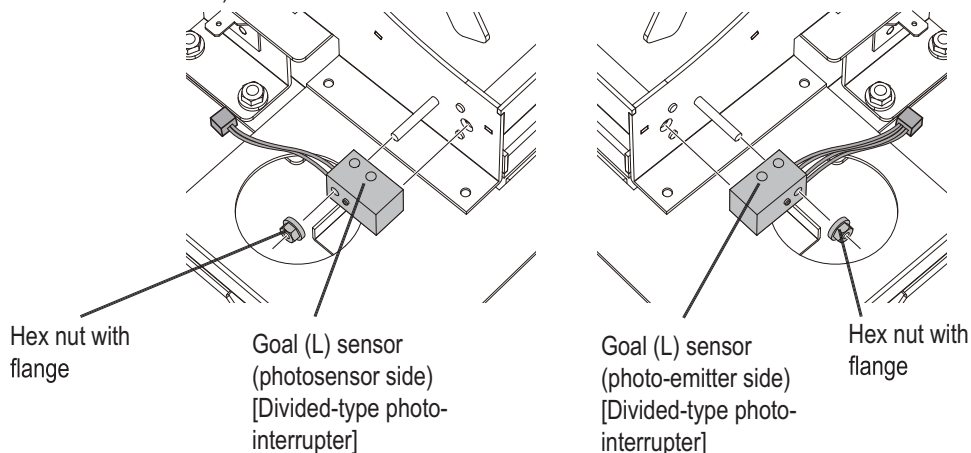

- 6** To install, perform the procedure in reverse.

(2) Replacing the Goal (L) and (R) Illumination PC Board

The description below explains how to replace the (L) side. Follow the same procedure for replacement of the (R) side.

! WARNING

- To avoid electric shock, accidents or injuries to yourself or other people, or damage to the electronic circuits, be sure to turn off the power switch before starting work.

NOTICE

- PC boards are sensitive to static electricity. If a person handles a PC board while charged with static electricity, the parts on the PC board may be damaged. Before handling a PC board, discharge the static electricity from your body; for example, by touching the surface of grounded metal.
- When installing, be careful not to pinch the harnesses and connectors

1

2

3

4

5

6

7

8A

8B

9

10

11

12

Removing, Installing and Replacing Assemblies and Parts

Test Mode

Troubleshooting

8B. Service

- Must be performed by a technician -

- 1** Turn off the power switch. (See "7-6-1 Turning the Power Switch On" on page 39.)
- 2** Open the goal (L) assembly. (See "7-5-3 Opening and Closing the Goal (L) and (R) Assemblies" on page 38.)
- 3** Remove the three countersunk bolts (M4 x 8), the four Hex nuts with flange (M4), and pull the Goal outer forward.

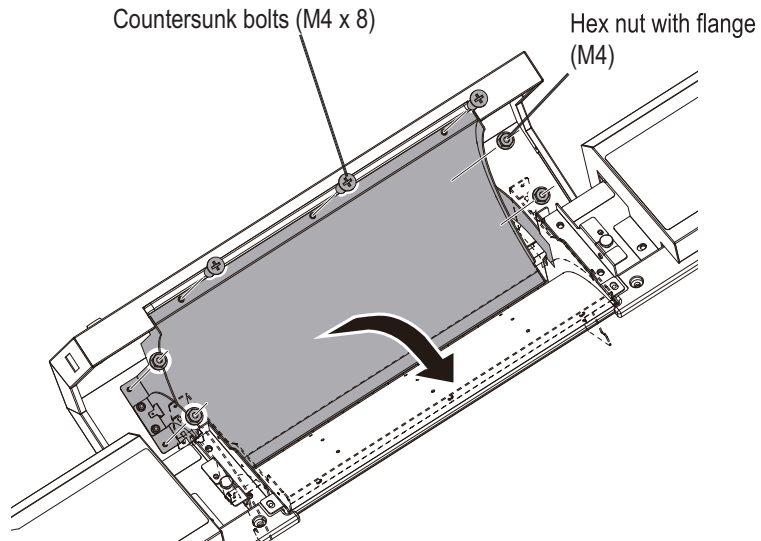

- 4** Disconnect the two connectors, remove the four pan head bolts (with flat and spring washers) ((M3 x 6), replace the Goal Illumination LED PC Board.

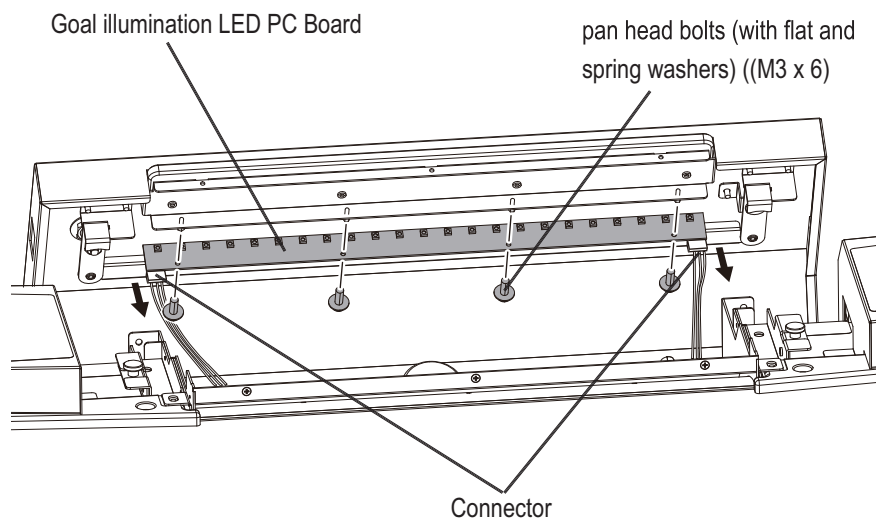

- 5** To install, perform the procedure in reverse.

- Must be performed by a technician -

8B-4-3 Rail (L) and (R) Assemblies

(1) Replacing the Rail (L) and (R) Sensors (A), (B) and (C)

The description below explains how to replace the (L) side. Follow the same procedure for replacement of the (R) side.

! WARNING

- To avoid electric shock, accidents or injuries to yourself or other people, or damage to the electronic circuits, be sure to turn off the power switch before starting work.

- 1 Turn off the power switch. (See "7-6-1 Turning the Power Switch On" on page 39.)
- 2 Open the service door L. (See "8A-5-2 Opening and Closing the Service Doors L and R" on page 87.)
- 3 Disconnect the three connectors of the rail (L) sensor (A), (B) and (C).
- 4 Remove the two Hex nuts with flange (M4), and remove the rail sensor bracket (L).

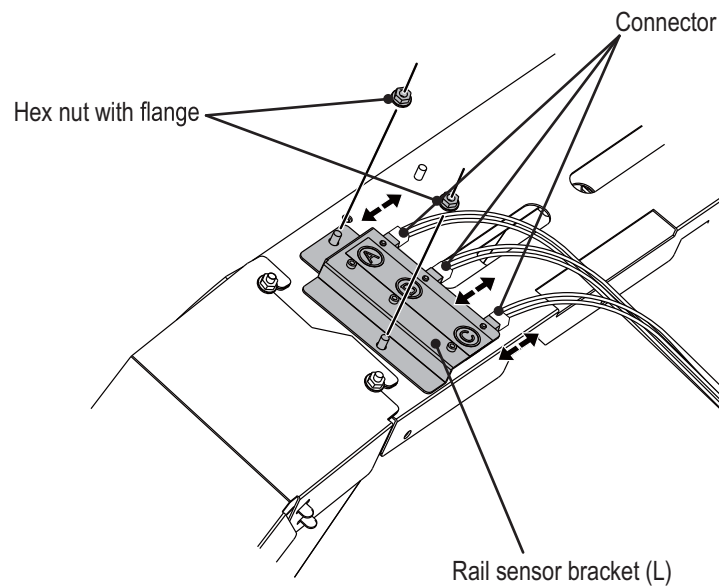

1

2

3

4

5

6

7

8A

8B

9

10

11

12

Removing, Installing and Replacing Assemblies and Parts

Test Mode

Troubleshooting

8B. Service

- Must be performed by a technician -

- 5 Remove the three pan head screws (M3 x 6), and remove the rail (L) sensors (A), (B) and (C).

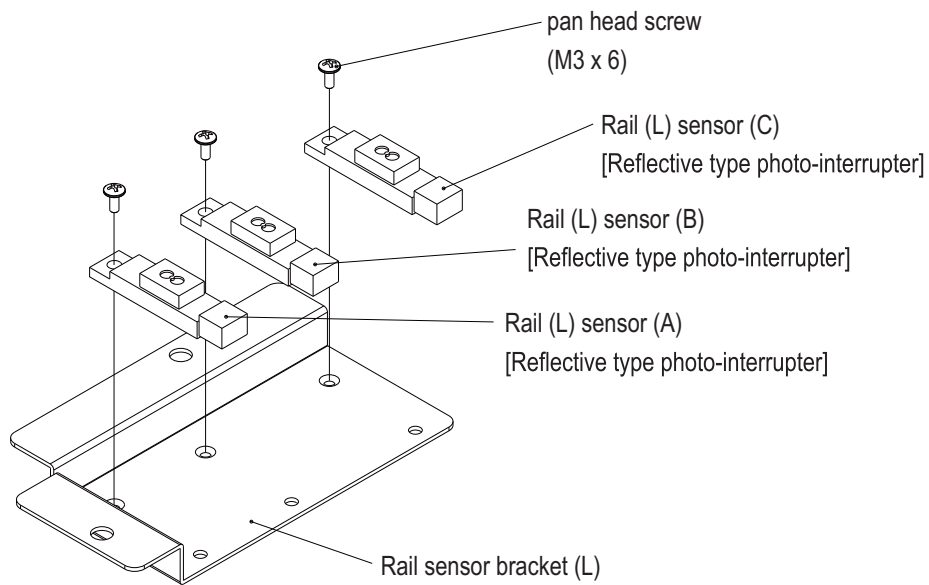

- 6 To install, perform the procedure in reverse.

- Must be performed by a technician -

(2) Replacing the L Stopper (L) and (R) Sensors

The description below explains how to replace the (L) side. Follow the same procedure for replacement of the (R) side.

! WARNING

● To avoid electric shock, accidents or injuries to yourself or other people, or damage to the electronic circuits, be sure to turn off the power switch before starting work.

- 1** Turn off the power switch. (See "7-6-1 Turning the Power Switch On" on page 39.)
- 2** Remove the goal (L) assembly. (See "8B-4-1 (1) Removing and Installing the Goal (L) and (R) Assemblies" on page 114.)
- 3** Disconnect the connector of the L Stopper (L) sensor.
- 4** Remove the two Hex nuts with flange (M3), and replace the photo sensor bracket.

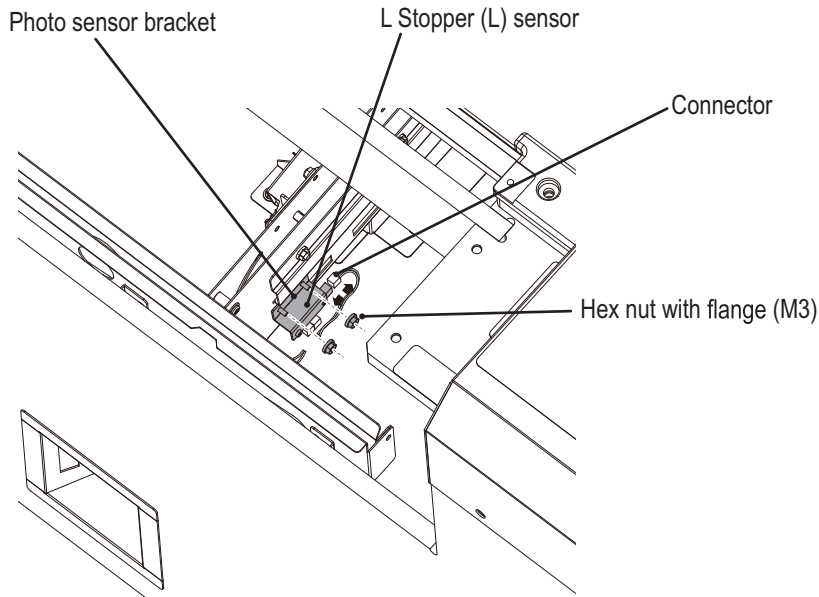

- 5** Remove the pan head screw (M3 x 6), and replace the L stopper (L) sensor.

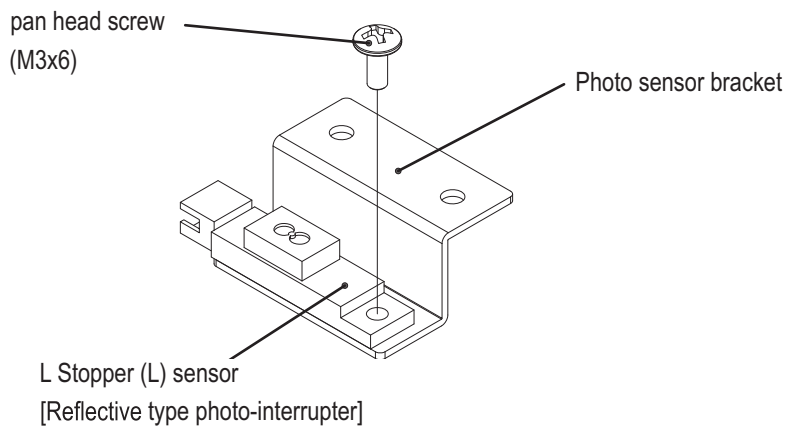

- 6** To install, perform the procedure in reverse.

- 1
- 2
- 3
- 4
- 5
- 6
- 7
- 8A
- 8B**
- 9
- 10
- 11
- 12

Removing, Installing and Replacing Assemblies and Parts

Test Mode

Troubleshooting

- Must be performed by a technician -

(3) Replacing the L Stopper (L) and (R) Solenoids

The description below explains how to replace the (L) side. Follow the same procedure for replacement of the (R) side.

! WARNING

● To avoid electric shock, accidents or injuries to yourself or other people, or damage to the electronic circuits, be sure to turn off the power switch before starting work.

- 1** Turn off the power switch. (See “7-6-1 Turning the Power Switch On” on page 39.)
- 2** Remove the goal (L) assembly. (See “8B-4-1 (1) Removing and Installing the Goal (L) and (R) Assemblies” on page 114.)
- 3** Disconnect the connector of the L Stopper (L) solenoid, cut the two tie wraps.
- 4** Remove the two Hex nuts with flange (M4), and remove the L out solenoid base (L).

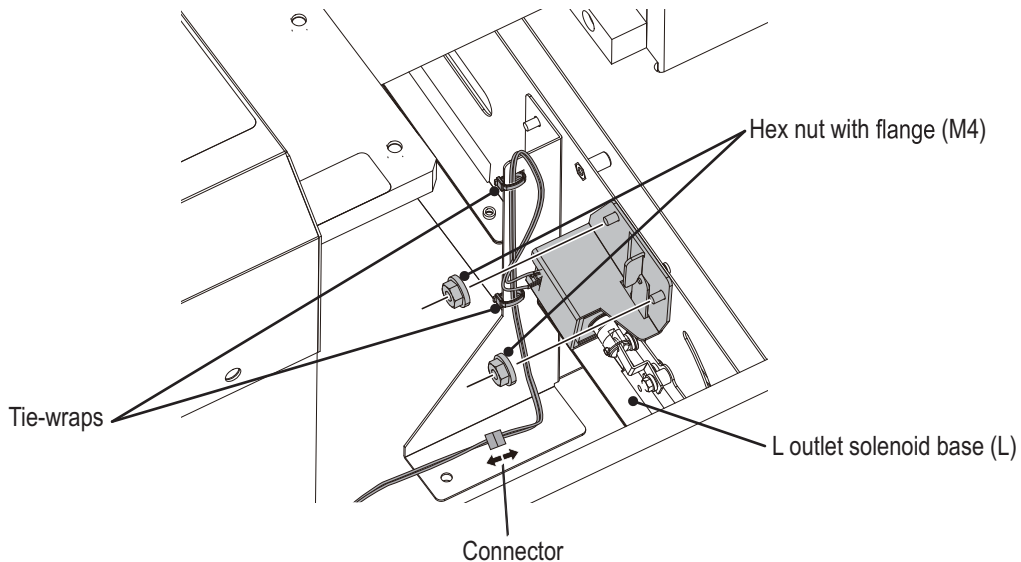

- 5** Remove the pan head screw (with flat and washers) (M3 x 6), and remove the L stopper (L) solenoid.

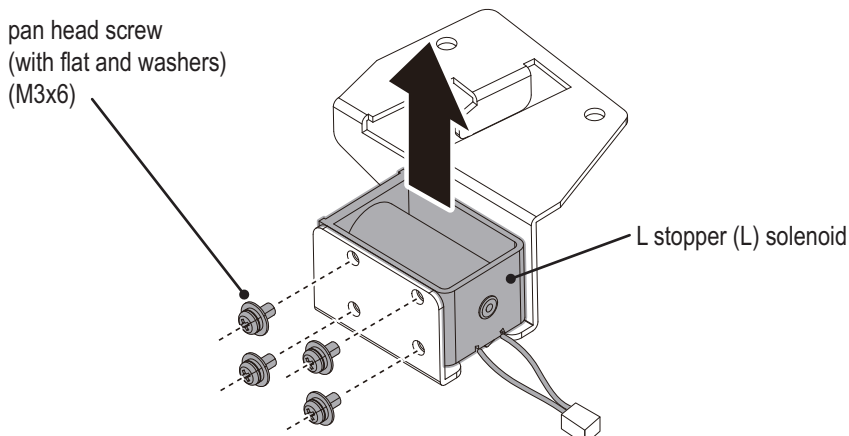

- Must be performed by a technician -

8B-4-4 Side tower assembly

(1) Removing and Installing the Side Tower Assembly

WARNING

- To avoid electric shock, accidents or injuries to yourself or other people, or damage to the electronic circuits, be sure to turn off the power switch before starting work.

- 1** Turn off the power switch. (See "7-6-1 Turning the Power Switch On" on page 39.)
- 2** Remove the side tower assembly by reversing the installation procedure. (See steps **3** - **10** of "8A-2-5 Installing the Side Tower Assembly" on page 81.)
- 3** To install, perform the procedure in reverse.

1

2

3

4

5

6

7

8A

8B

9

10

11

12

Removing, Installing and Replacing Assemblies and Parts

Test Mode

Troubleshooting

- Must be performed by a technician -

(2) Replacing the Main PC Board

! WARNING

● To avoid electric shock, accidents or injuries to yourself or other people, or damage to the electronic circuits, be sure to turn off the power switch before starting work.

NOTICE

● PC boards are sensitive to static electricity. If a person handles a PC board while charged with static electricity, the parts on the PC board may be damaged. Before handling a PC board, discharge the static electricity from your body; for example, by touching the surface of grounded metal.

- 1** Turn off the power switch. (See "7-6-1 Turning the Power Switch On" on page 39.)
- 2** Disconnect the faston terminal in the PCB base, and remove the two wing bolts (M4 x 17).
- 3** Pull out the PCB base, disconnect the 15 connectors.

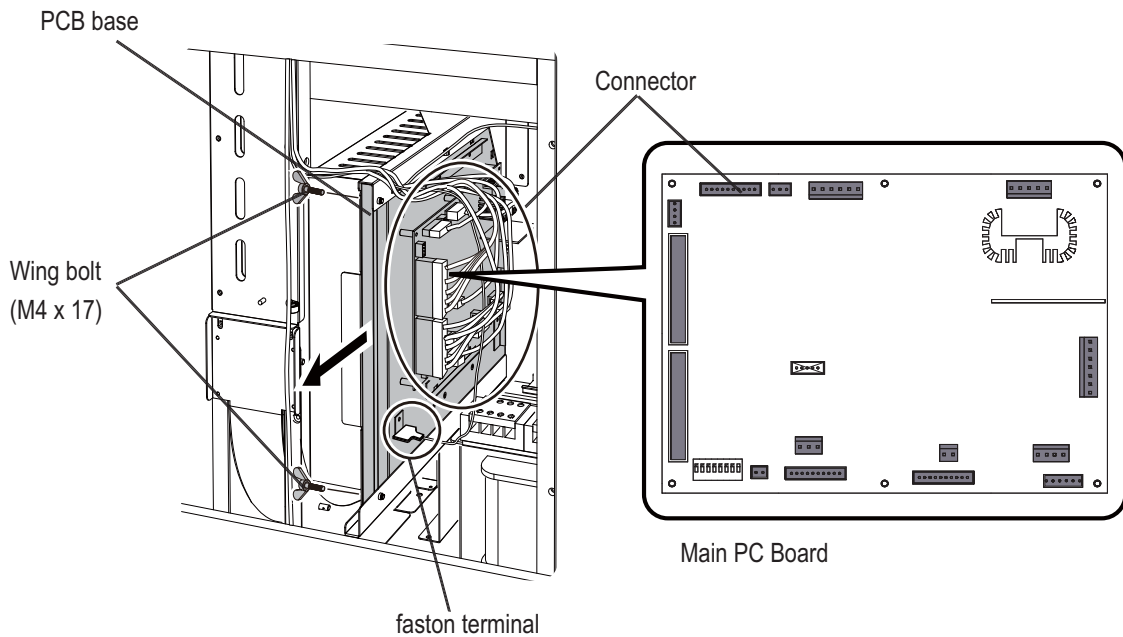

- Must be performed by a technician -

- 4** Remove the six pan head screws (with flat and spring washers) (M3 x 6), and replace the main PC board.

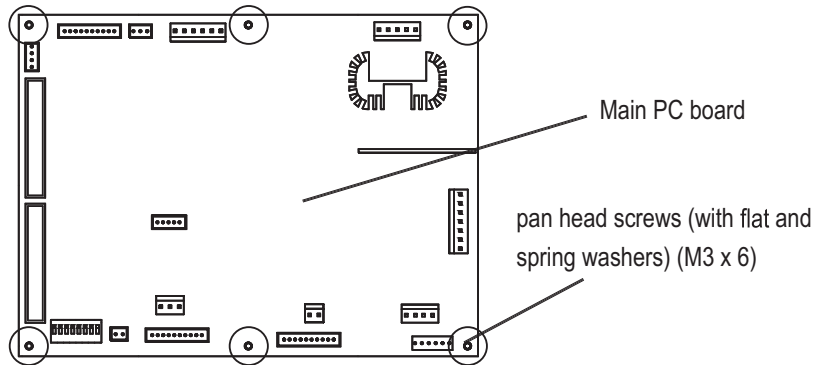

- 5** To install, perform the procedure in reverse.

1

2

3

4

5

6

7

8A

8B

9

10

11

12

Removing, Installing and Replacing Assemblies and Parts

Test Mode

Troubleshooting

- Must be performed by a technician -

(3) Replacing the Switching Regulator

! WARNING

- To avoid electric shock, accidents or injuries to yourself or other people, or damage to the electronic circuits, be sure to turn off the power switch before starting work.

NOTICE

- PC boards are sensitive to static electricity. If a person handles a PC board while charged with static electricity, the parts on the PC board may be damaged. Before handling a PC board, discharge the static electricity from your body; for example, by touching the surface of grounded metal.

- 1** Turn off the power switch. (See “7-6-1 Turning the Power Switch On” on page 39.)
- 2** Disconnect the faston terminal in the PCB base, remove the two wing bolts (M4 x 17), and pull out the PCB base. (See steps **2** of “8B-4-4 (2) Replacing the Main PC Board” on page 126.)
- 3** Remove the two cap screws (M3 x 6), and remove the regulator cover.

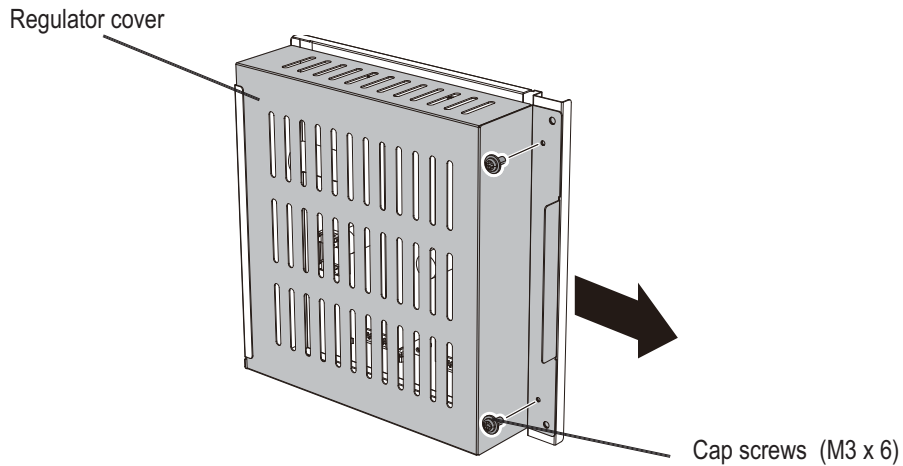

- Must be performed by a technician -

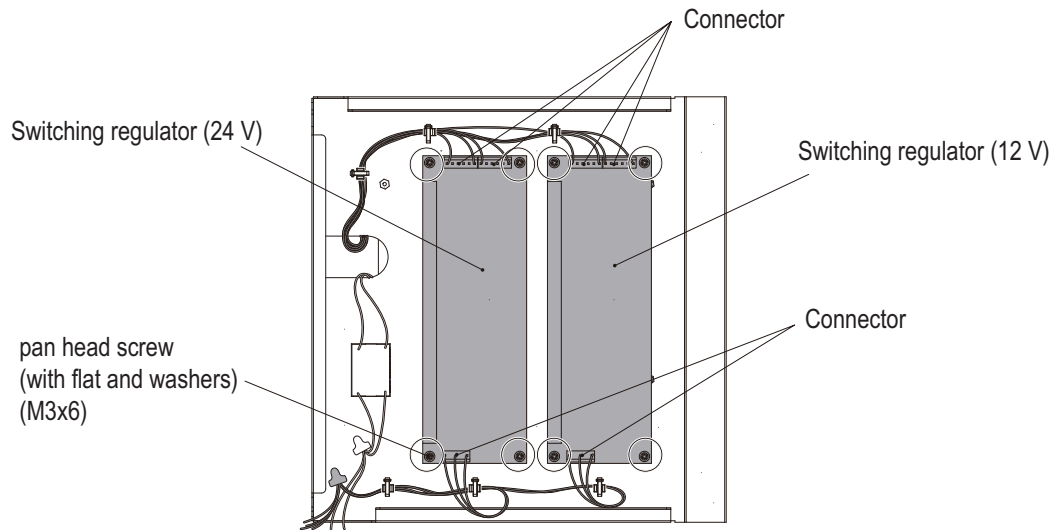

- 4** Disconnect the three connectors of the switching regulator.
- 5** Remove the four pan head screws (with flat and spring washers) (M3 x 6), and replace the switching regulator.
- 6** To install, perform the procedure in reverse.

1

2

3

4

5

6

7

8A

8B

9

10

11

12

Removing, Installing and Replacing Assemblies and Parts

Test Mode

Troubleshooting

- Must be performed by a technician -

(4) Replacing the SSR

! WARNING

● To avoid electric shock, accidents or injuries to yourself or other people, or damage to the electronic circuits, be sure to turn off the power switch before starting work.

- 1** Turn off the power switch. (See "7-6-1 Turning the Power Switch On" on page 39.)
- 2** Disconnect the faston terminal in the PCB base, remove the two wing bolts (M4 x 17), and pull out the PCB base. (see steps **2** of "8B-4-4 (2) Replacing the Main PC Board" on page 126.)
- 3** Remove the two cap screws (M3 x 6), and remove the regulator cover. (See steps **3** of "8B-4-4 (3) Replacing the Switching Regulator" on page 128.)
- 4** Remove the four faston terminal.

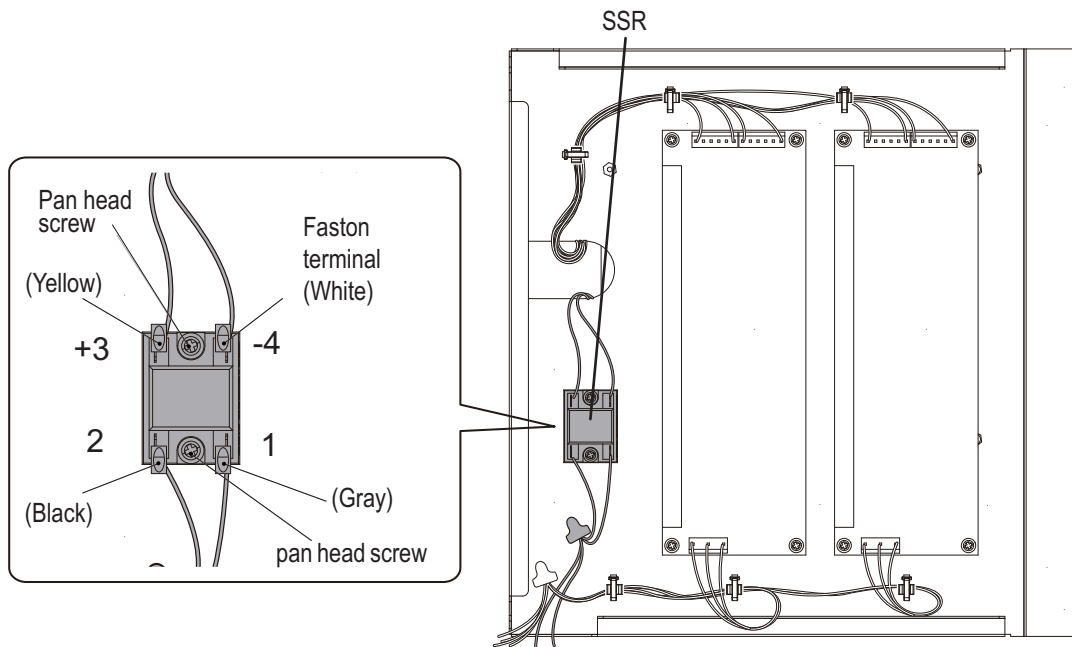

- 5** Remove the two pan head screws (with flat and spring washers) (M3 x 10), and remove the SSR.
- 6** To install, perform the procedure in reverse.

NOTICE

- 6** The SSR has a polarity.
The numbers indicated in the figure are marked on the SSR, so be careful and install the SSR with the correct alignment.
- 6** When installing, be careful not to mix up the Faston terminal colors.

- Must be performed by a technician -

8B-4-5 S Hopper assembly

(1) Replacing the S Hopper Motor

! WARNING

- To avoid electric shock, accidents or injuries to yourself or other people, or damage to the electronic circuits, be sure to turn off the power switch before starting work.

- 1 Turn off the power switch. (See "7-6-1 Turning the Power Switch On" on page 39.)
- 2 Remove the side tower assembly by reversing the installation procedure. (See steps 3 - 10 of "8A-2-5 Installing the Side Tower Assembly" on page 81.)
- 3 Remove the wing bolt (M4 x10), slide the S hopper cover toward the outside, and remove it.

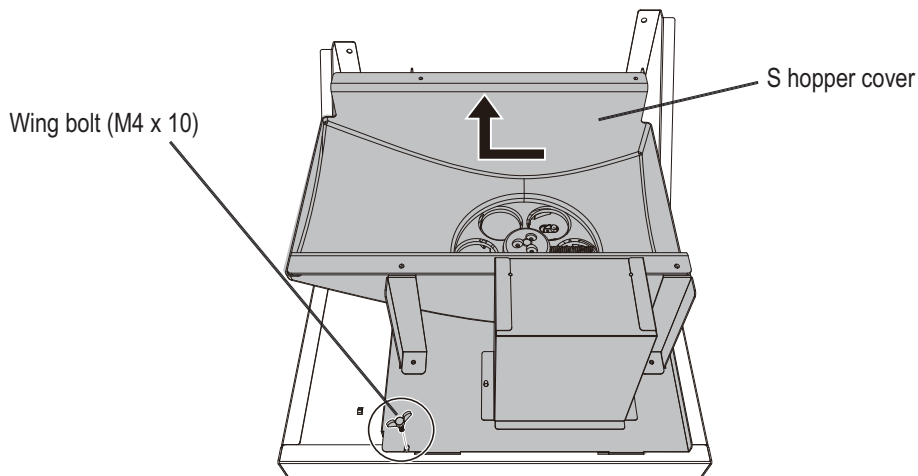

- 4 Disconnect the two connectors.
- 5 Loosen the four pan head screws (with flat and spring washers) (M4 x 10), and remove the S hopper motor bracket.

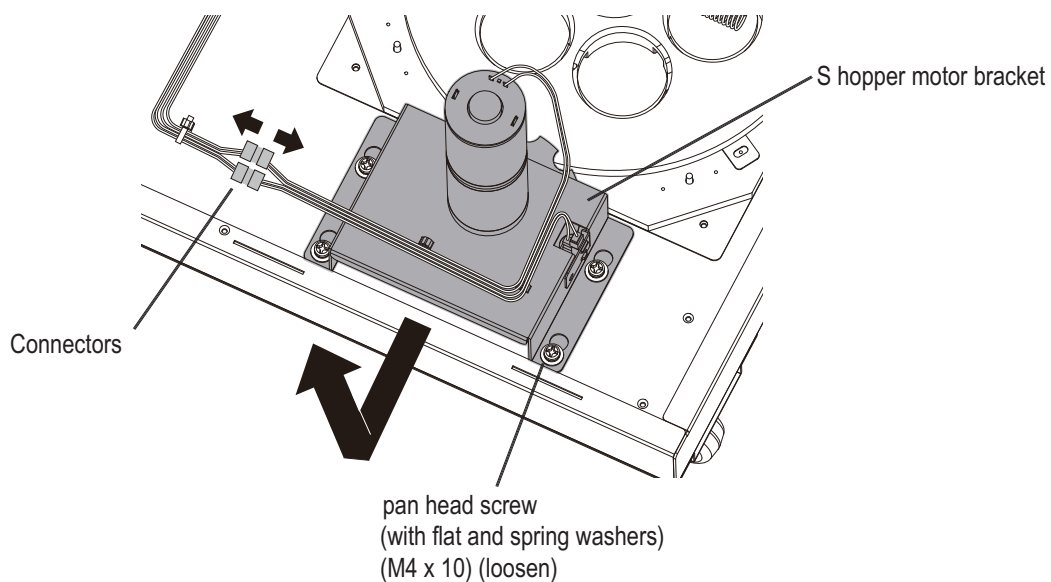

1

2

3

4

5

6

7

8A

8B

9

10

11

12

Removing, Installing and Replacing Assemblies and Parts

Test Mode

Troubleshooting

8B. Service

- Must be performed by a technician -

6 Remove the encoder bracket. (See the step **3** of "8B-4-5 (2) Replacing the S Hopper Motor Sensor" on page 134.)

7 Remove the two double points (M4 x 10), and remove the S hopper gear.

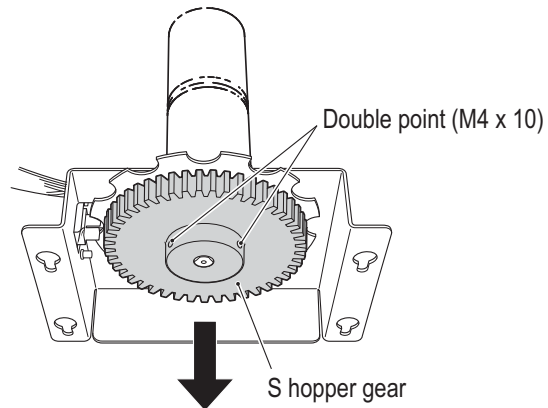

8 Remove the four pan head screws (with flat and spring washers) (M5 x 10), and replace the S hopper motor.

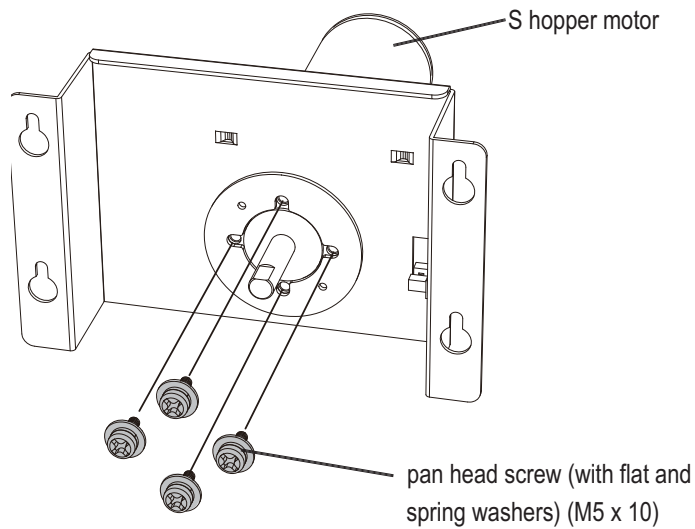

- Must be performed by a technician -

9 To install, perform the procedure in reverse.



- When installing, align the bottom surface of the hopper gear with the tip of the motor shaft.

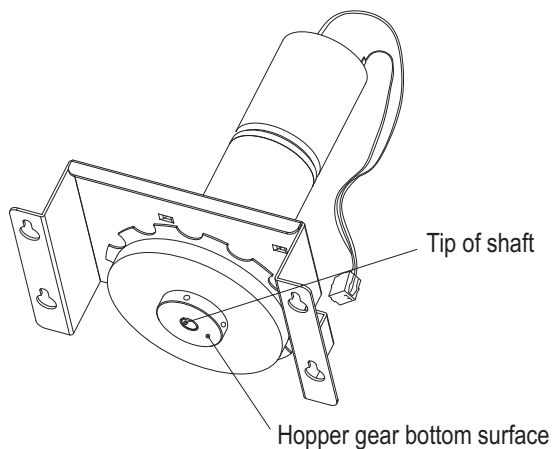

- When installing, install so that the double points are perpendicular to the flat surfaces of the motor shaft.

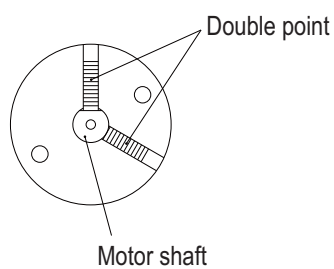

- When installing, press the hopper motor bracket toward the hopper disk so that the hopper gear and hopper disk teeth mesh properly.

1

2

3

4

5

6

7

8A

8B

9

10

11

12

Removing, Installing and Replacing Assemblies and Parts

Test Mode

Troubleshooting

- Must be performed by a technician -

(2) Replacing the S Hopper Motor Sensor

! WARNING

● To avoid electric shock, accidents or injuries to yourself or other people, or damage to the electronic circuits, be sure to turn off the power switch before starting work.

- 1** Turn off the power switch. (See “7-6-1 Turning the Power Switch On” on page 39.)
- 2** Remove the S hopper motor bracket. (See steps **2** - **5** of “8B-4-5 (1) Replacing the S Hopper Motor” on page 131.)
- 3** Remove the cross flange socket bolt (M4 x 6), and remove the encoder bracket.

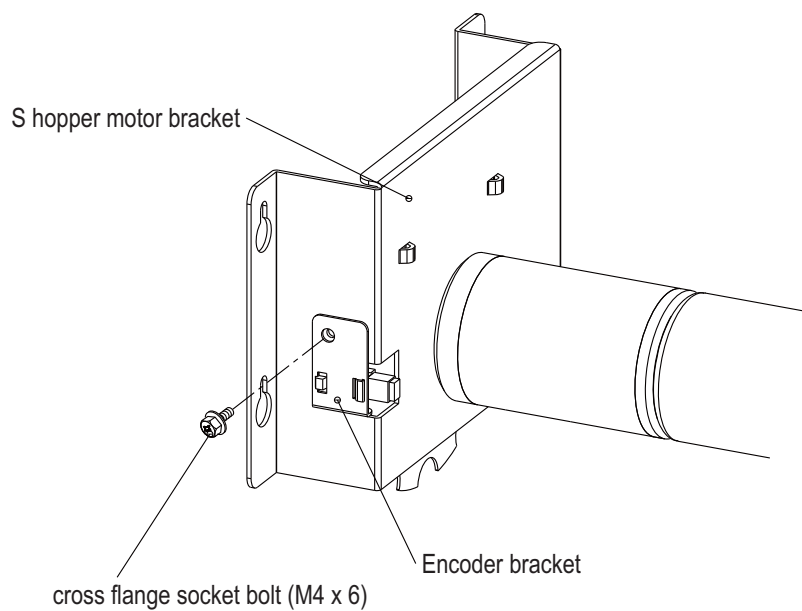

- 4** Release the lock, and replace the S hopper motor sensor.

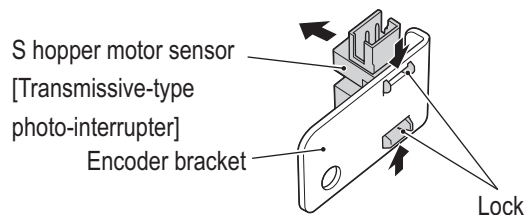

- 5** To install, perform the procedure in reverse.

- Must be performed by a technician -

8B-4-6 Slider Assembly

(1) Replacing the S Stopper Solenoid

! WARNING

● To avoid electric shock, accidents or injuries to yourself or other people, or damage to the electronic circuits, be sure to turn off the power switch before starting work.

- 1 Turn off the power switch. (See "7-6-1 Turning the Power Switch On" on page 39.)
- 2 Remove the rear panel. (See "8A-5-3 Opening and Closing the Rear Panel" on page 88.)
- 3 Open the coating clip, and release the harness. And disconnect the connector.
- 4 Remove the four pan head screws (with flat and spring washers) (M3 x 6), and remove the S stopper solenoid.

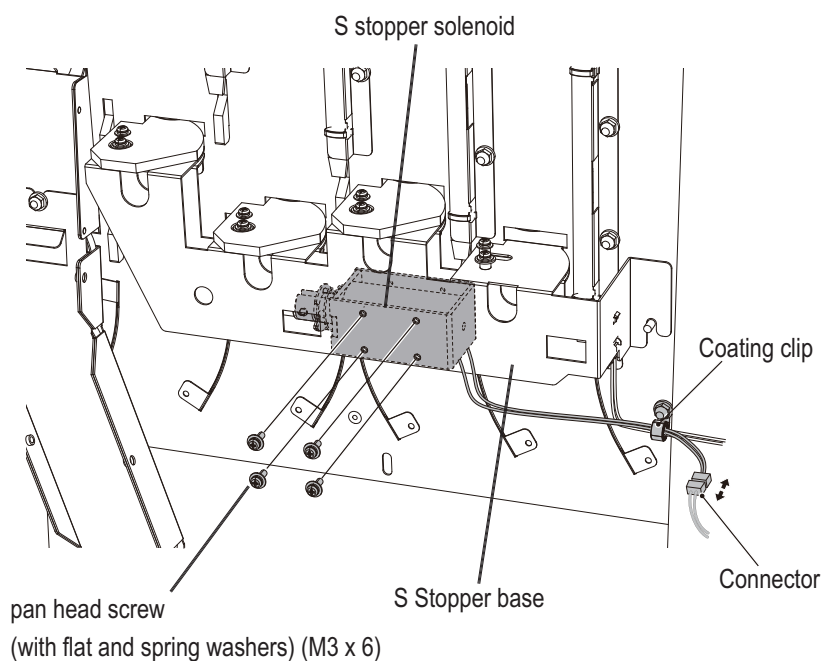

- 5 To install, perform the procedure in reverse.

1

2

3

4

5

6

7

8A

8B

9

10

11

12

Removing, Installing and Replacing Assemblies and Parts

Test Mode

Troubleshooting

- Must be performed by a technician -

(2) Replacing the S Stopper Sensor

! WARNING

● To avoid electric shock, accidents or injuries to yourself or other people, or damage to the electronic circuits, be sure to turn off the power switch before starting work.

- 1** Turn off the power switch. (See "7-6-1 Turning the Power Switch On" on page 39.)
- 2** Remove the rear panel. (See "8A-5-3 Opening and Closing the Rear Panel" on page 88.)
- 3** Disconnect the connector, release the lock, and remove the S stopper sensor.

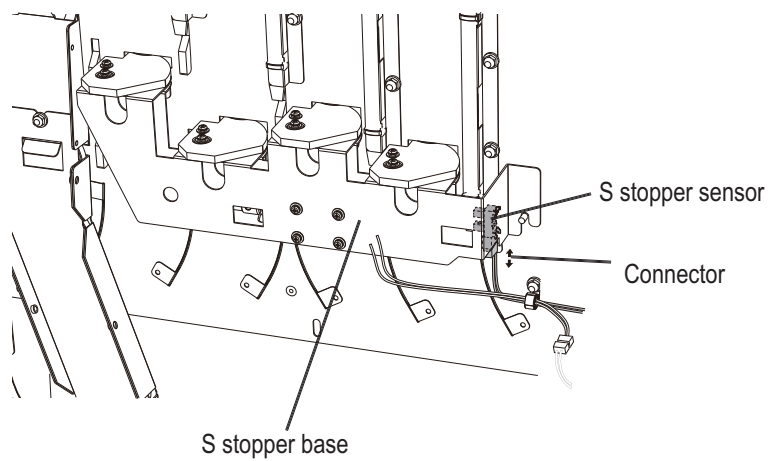

- 4** To install, perform the procedure in reverse.

- Must be performed by a technician -

(3) Replacing the Time LED (Time LED PC Board)

WARNING

- To avoid electric shock, accidents or injuries to yourself or other people, or damage to the electronic circuits, be sure to turn off the power switch before starting work.

NOTICE

- PC boards are sensitive to static electricity. If a person handles a PC board while charged with static electricity, the parts on the PC board may be damaged. Before handling a PC board, discharge the static electricity from your body; for example, by touching the surface of grounded metal.

- 1** Turn off the power switch. (See "7-6-1 Turning the Power Switch On" on page 39.)
- 2** Remove the cover panel. (See steps **2** - **3** of "8B-1-2 (5) Cleaning the Slider Assembly" on page 96.)
- 3** Disconnect the connector, remove the four pan head bolts (with flat and spring washers) (M3 x 6), and replace the time LED (time LED PC board).

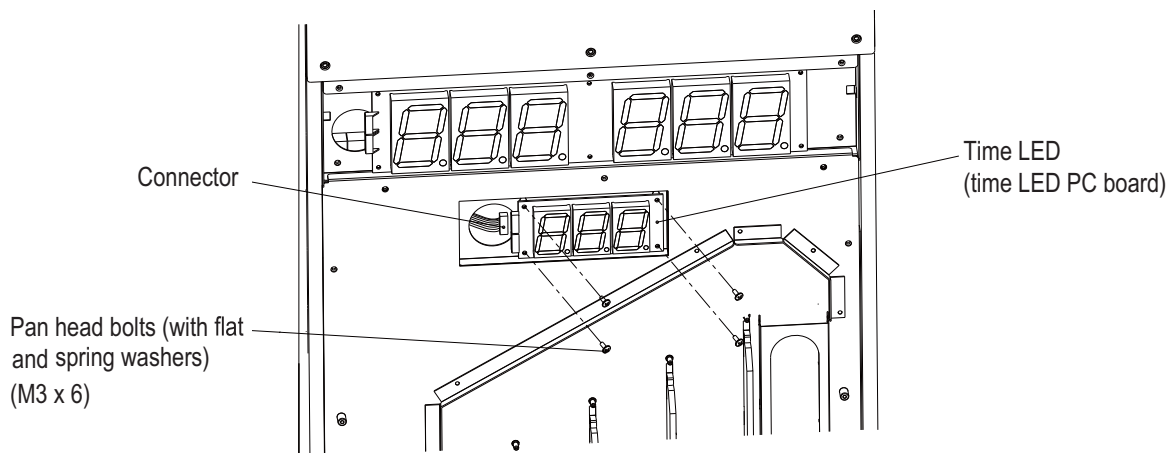

- 4** To install, perform the procedure in reverse.

1

2

3

4

5

6

7

8A

8B

9

10

11

12

Removing, Installing and Replacing Assemblies and Parts

Test Mode

Troubleshooting

- Must be performed by a technician -

(4) Replacing the Score LED (Score LED PC Board)

! WARNING

- To avoid electric shock, accidents or injuries to yourself or other people, or damage to the electronic circuits, be sure to turn off the power switch before starting work.

NOTICE

- PC boards are sensitive to static electricity. If a person handles a PC board while charged with static electricity, the parts on the PC board may be damaged. Before handling a PC board, discharge the static electricity from your body; for example, by touching the surface of grounded metal.

- 1** Turn off the power switch. (See "7-6-1 Turning the Power Switch On" on page 39.)
- 2** Remove the cover panel. (See steps **2** - **3** of "8B-1-2 (5) Cleaning the Slider Assembly" on page 96.)
- 3** Disconnect the two connectors, remove the six pan head bolts (with flat and spring washers) (M3 x 6), and replace the score LED (score LED PC board).

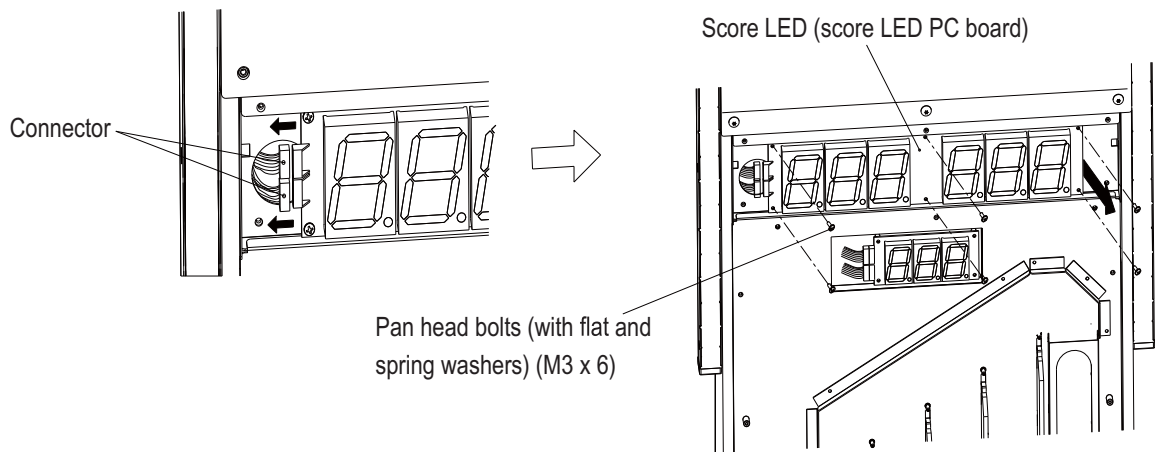

- 4** To install, perform the procedure in reverse.

- Must be performed by a technician -

(5) Replacing the S Stoker LED

WARNING

- To avoid electric shock, accidents or injuries to yourself or other people, or damage to the electronic circuits, be sure to turn off the power switch before starting work.

NOTICE

- PC boards are sensitive to static electricity. If a person handles a PC board while charged with static electricity, the parts on the PC board may be damaged. Before handling a PC board, discharge the static electricity from your body; for example, by touching the surface of grounded metal.
- When installing, be careful not to pinch the harnesses and connectors.

- 1** Turn off the power switch. (See "7-6-1 Turning the Power Switch On" on page 39.)
- 2** Remove the rear panel. (See "8A-5-3 Opening and Closing the Rear Panel" on page 88.)
- 3** Disconnect the two connectors, and remove the two Hex nut with flange (M4).
(In the figure, it is explained by the second S stoker LED from the left)

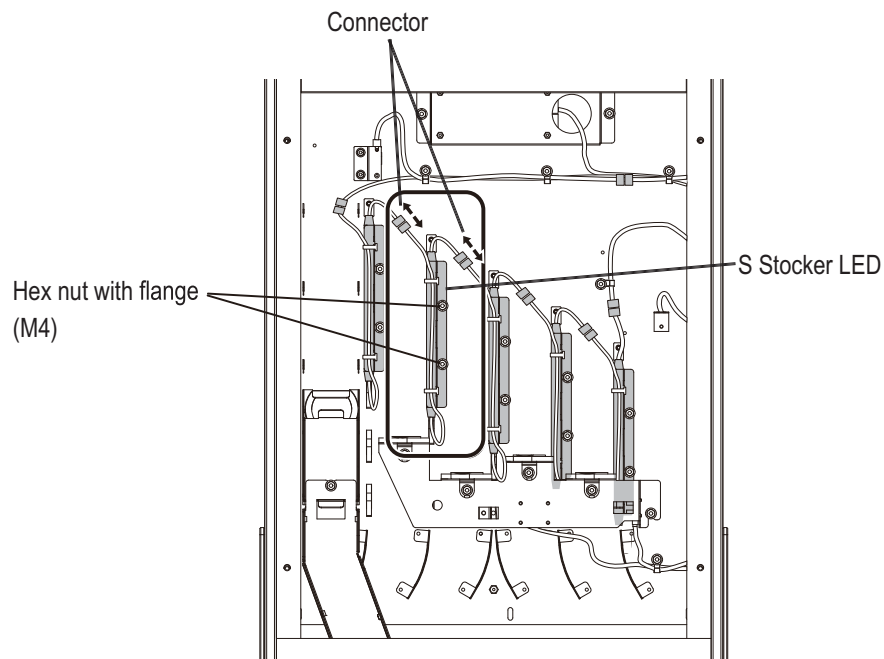

1

2

3

4

5

6

7

8A

8B

9

10

11

12

Removing, Installing and Replacing Assemblies and Parts

Test Mode

Troubleshooting

8B. Service

- Must be performed by a technician -

- 4 Release the two Tie-wraps (100mm) , and replace the S stocker LED.

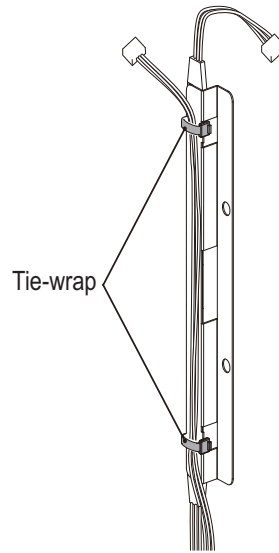

- 5 To install, perform the procedure in reverse.

- Must be performed by a technician -

(6) Replacing the S Escalator Outlet Sensor

! WARNING

- To avoid electric shock, accidents or injuries to yourself or other people, or damage to the electronic circuits, be sure to turn off the power switch before starting work.

- 1 Turn off the power switch. (See "7-6-1 Turning the Power Switch On" on page 39.)
- 2 Remove the rear panel. (See "8A-5-3 Opening and Closing the Rear Panel" on page 88.)
- 3 Disconnect the connector, remove the two Hex nuts with flange (M3), and remove the photo sensor bracket.

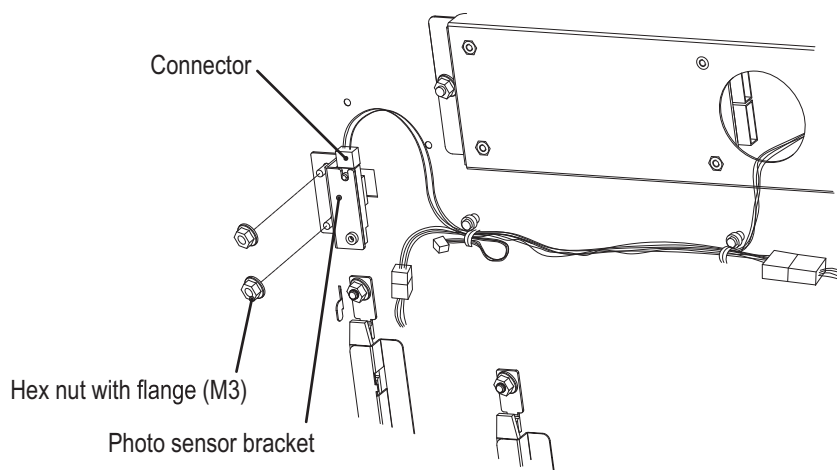

- 4 Remove the pan head screw (M3 x 6), and replace the S escalator out sensor.

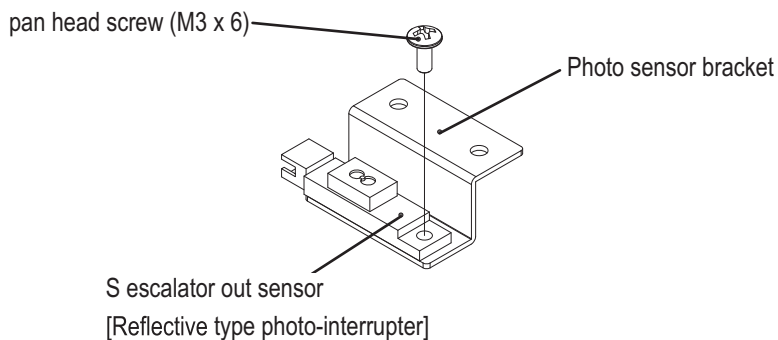

- 5 To install, perform the procedure in reverse.

1

2

3

4

5

6

7

8A

8B

9

10

11

12

Removing, Installing and Replacing Assemblies and Parts

Test Mode

Troubleshooting

- Must be performed by a technician -

8B-4-7 L Outlet (L) and (R) Assemblies

(1) Replacing the L Outlet (L) and (R) Sensors

The description below explains how to replace the (L) side. Follow the same procedure for replacement of the (R) side.

! WARNING

● To avoid electric shock, accidents or injuries to yourself or other people, or damage to the electronic circuits, be sure to turn off the power switch before starting work.

- 1** Turn off the power switch. (See "7-6-1 Turning the Power Switch On" on page 39.)
- 2** Remove the goal (L) assembly. (See "8B-4-1 (1) Removing and Installing the Goal (L) and (R) Assemblies" on page 114.)
- 3** Disconnect the three connectors and faston terminal.
- 4** Remove the four Hex nuts with flange (M4), and remove the L outlet assembly.

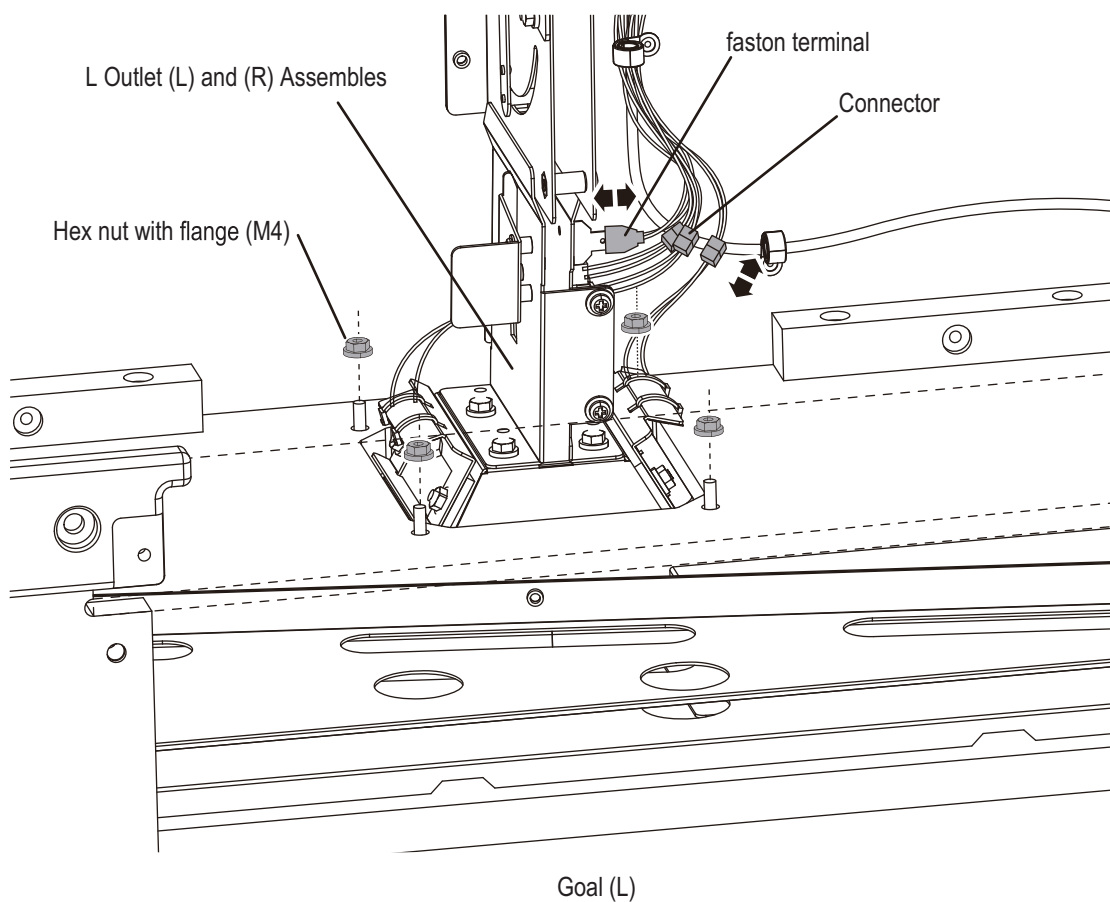

- Must be performed by a technician -

- 5** Disconnect the connector, remove the two hex nuts with flange (M4), and remove the photo sensor bracket.

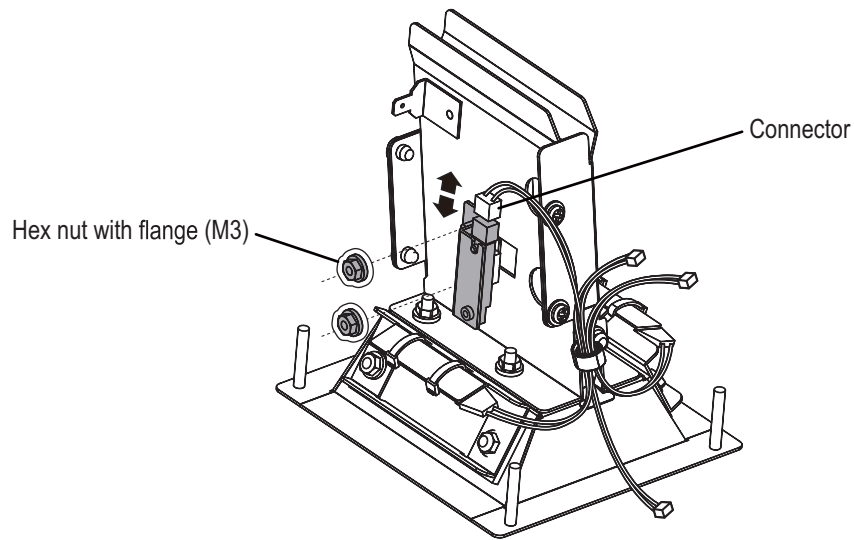

- 6** Remove the pan head screw (M3 x 6), and replace the L outlet sensor.

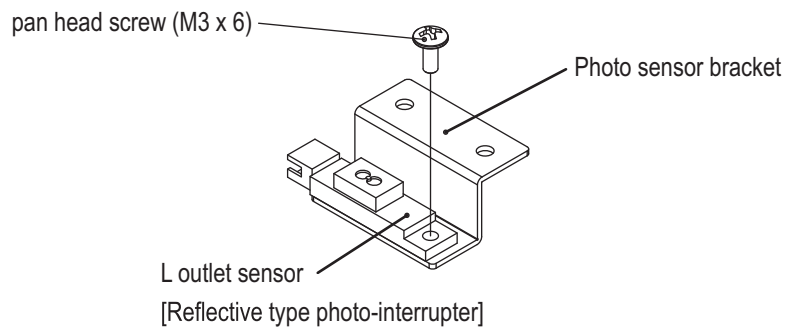

- 7** To install, perform the procedure in reverse.

1

2

3

4

5

6

7

8A

8B

9

10

11

12

Removing, Installing and Replacing Assemblies and Parts

Test Mode

Troubleshooting

- Must be performed by a technician -

(2) Replacing the L Outlet LED

The description below explains how to replace the (L) side. Follow the same procedure for replacement of the (R) side.

! WARNING

- To avoid electric shock, accidents or injuries to yourself or other people, or damage to the electronic circuits, be sure to turn off the power switch before starting work.

NOTICE

- PC boards are sensitive to static electricity. If a person handles a PC board while charged with static electricity, the parts on the PC board may be damaged. Before handling a PC board, discharge the static electricity from your body; for example, by touching the surface of grounded metal.
- When installing, be careful not to pinch the harnesses and connectors

- 1** Turn off the power switch. (See “7-6-1 Turning the Power Switch On” on page 39.)
- 2** Remove the goal (L) assembly. (See “8B-4-1 (1) Removing and Installing the Goal (L) and (R) Assemblies” on page 114.)
- 3** Remove the L outlet assembly. (See steps **3** - **4** of “8B-4-7 (1) Replacing the L Outlet (L) and (R) Sensors” on page 142.)
- 4** Loosen the clip, cut the two Tie-wraps (100mm), and replace the L outlet LED.

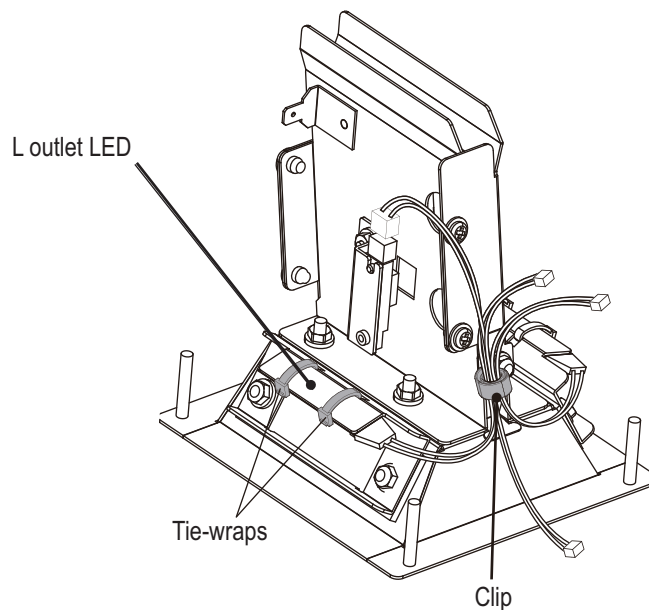

- 5** To install, perform the procedure in reverse.

- Must be performed by a technician -

8B-4-8 Light Assembly

(1) Replacing the Light LED PC Board

The description below explains how to replace the (L) side. Follow the same procedure for replacement of the (R) side.

WARNING

- To avoid electric shock, accidents or injuries to yourself or other people, or damage to the electronic circuits, be sure to turn off the power switch before starting work.

NOTICE

- PC boards are sensitive to static electricity. If a person handles a PC board while charged with static electricity, the parts on the PC board may be damaged. Before handling a PC board, discharge the static electricity from your body; for example, by touching the surface of grounded metal.

- 1 Turn off the power switch. (See "7-6-1 Turning the Power Switch On" on page 39.)
- 2 Loosen the two pan head bolts (with flat and washers) (M4 x 8), and disconnect the connector.

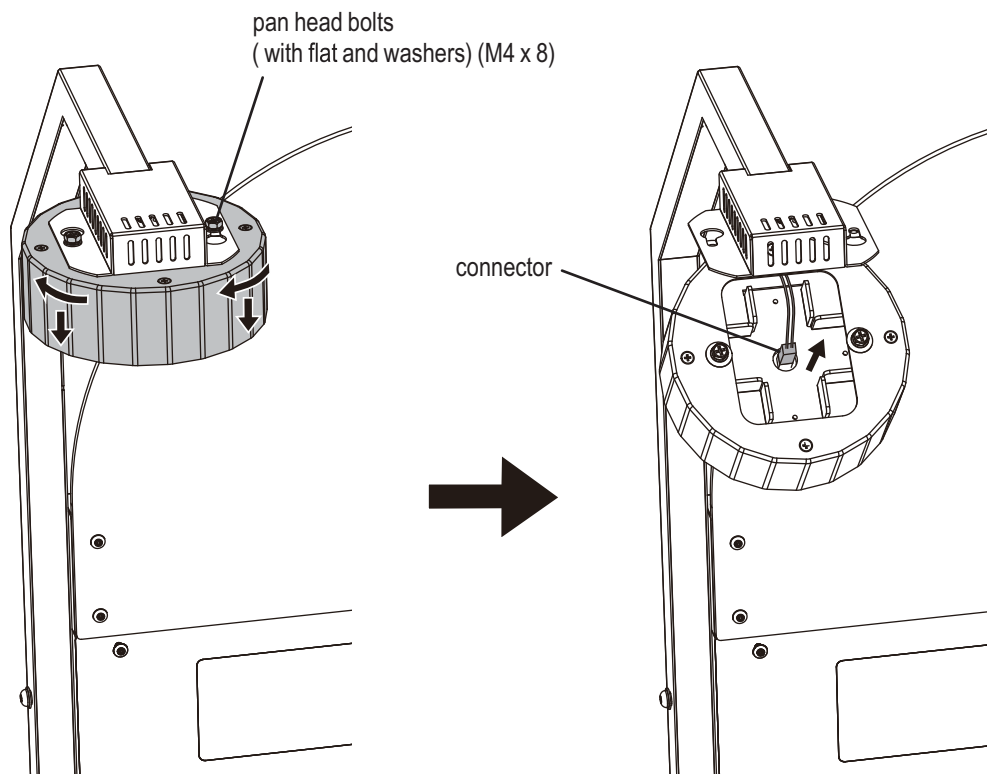

1

2

3

4

5

6

7

8A

8B

9

10

11

12

Removing, Installing and Replacing Assemblies and Parts

Test Mode

Troubleshooting

8B. Service

- Must be performed by a technician -

- 3** Remove the four countersunk bolts (M4 x 8) and light cover.
Remove the four pan head bolts (M3 x 6) and replace Led light PC Board.
To install, perform the procedure in reverse

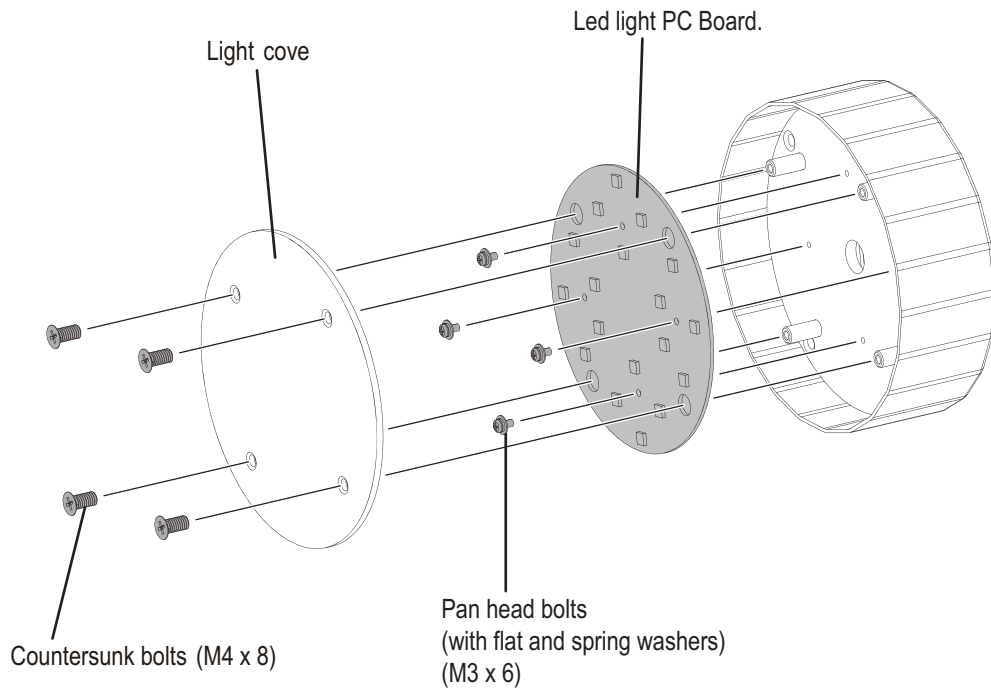

9. Disposal

WARNING

- When disposing of the machine, follow the applicable regulations for collection, transportation and disposal.
- When delegating the collection, transportation and disposal of the machine, be sure to delegate to specialists in each field.

1

2

3

4

5

6

7

8A

8B

9

10

11

12

Disposal

Test Mode

Troubleshooting

10. Parts List

10-1 Overall

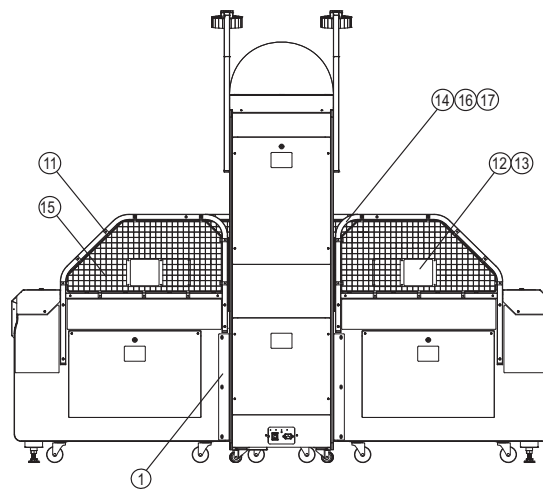
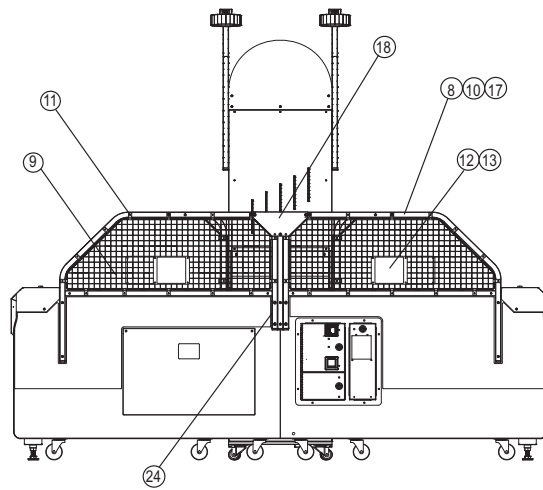
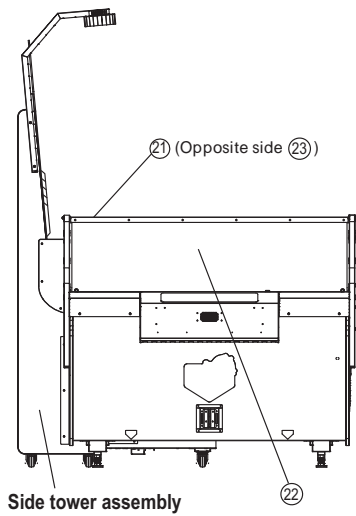
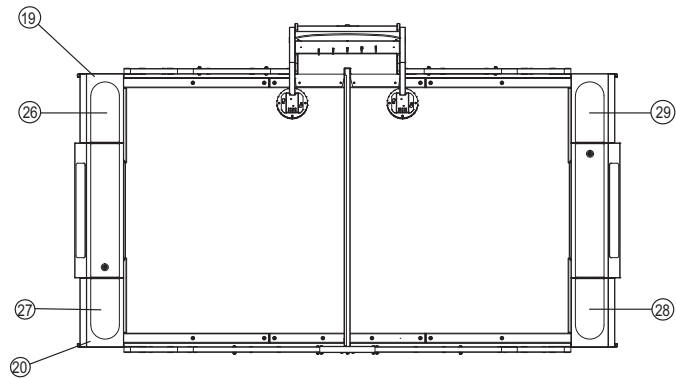

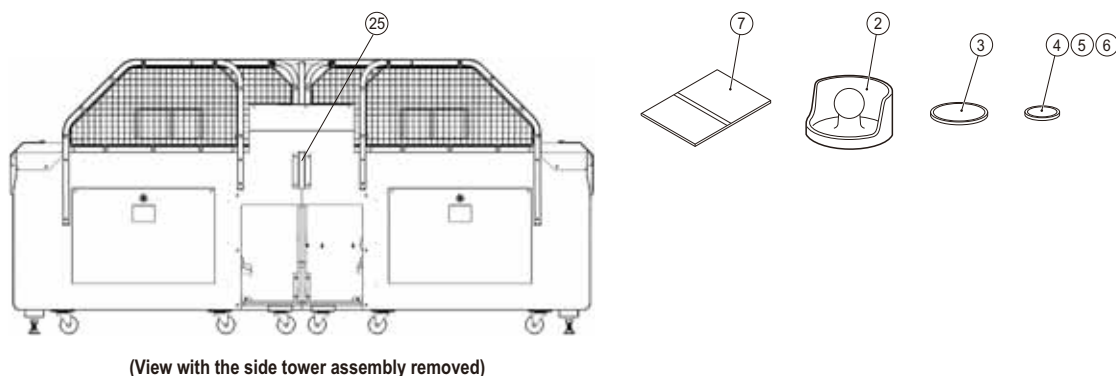

No.	Name	Qty.	Type and rating	Part No.
1	Side tower bracket	2		742-233
2	Mallet	4		731-322
3	Big puck	10	(1 set: 10 pucks)	731-323
4	Mini puck (green)	50	1 set: 60 pucks (20 pucks of each color)	731-349
5	Mini puck (pink)	50		
6	Mini puck (orange)	50		
7	Operation Manual (English)	1		742-223
8	Net L frame	2		742-400
9	Net L	2		742-401
10	Net L frame bracket	2		742-402
11	Net fixing bracket	48		731-329
12	Caution sticker Do Not Approach Net EXP	4		461-771
13	Sticker plate	4		731-346
14	Net S frame	2		742-405
15	Net S	2		742-406
16	Net S frame bracket	2		742-407
17	Pipe cap	11		742-435
18	Triangle bracket	1		742-410
19	Corner cover (L)	2		742-282
20	Corner cover (R)	2		742-283
21	Center guard frame	1		742-420
22	Center guard	1		742-421
23	Center guard retainer	1		742-422
24	Center guard bracket (A)	1		742-411
25	Center guard bracket (B)	1		742-412
26	Corner cover (L) sticker EXP (pink)	1		742-634
27	Corner cover (R) sticker EXP (pink)	1		742-636
28	Corner cover (L) sticker EXP (green)	1		742-615
29	Corner cover (R) sticker EXP (green)	1		742-617
30	Power Cord UL (U.S.)	1		
	Power Cord BIZ (Europe)	1		

1

2

3

4

5

6

7

8A

8B

9

10

11

12

Overall

Test Mode

Troubleshoot-

10-2 Table top assembly

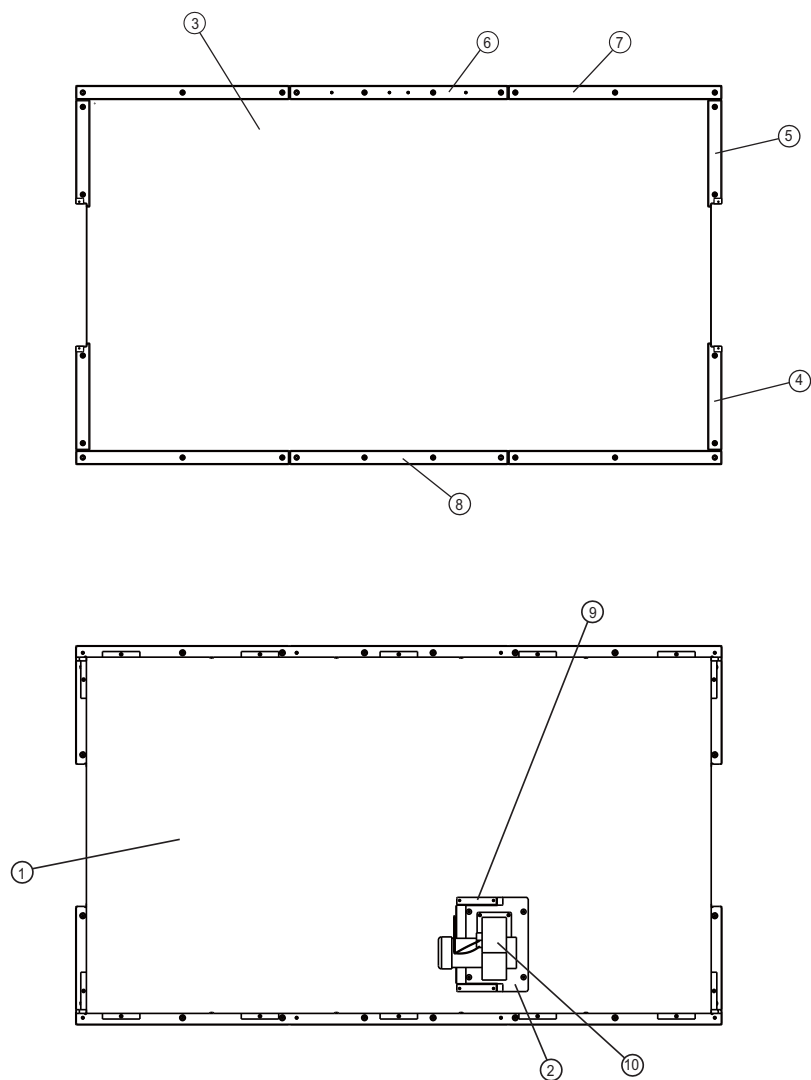

No.	Name	Qty.	Type and rating	Part No.
1	Air chamber(EXP)	1		742-385
2	Blower mounting plate	1		742-395
3	Blower fan	1	CY120_100-110V_60HZ	005-587
4	Goal bumper (L)	2		742-391
5	Goal bumper (R)	2		742-390
6	Bumper A	1		742-387
7	Bumper B	4		742-388
8	Bumper C	1		742-389
9	Blower bracket	1		742-392

10-3 Cabinet (L) assembly

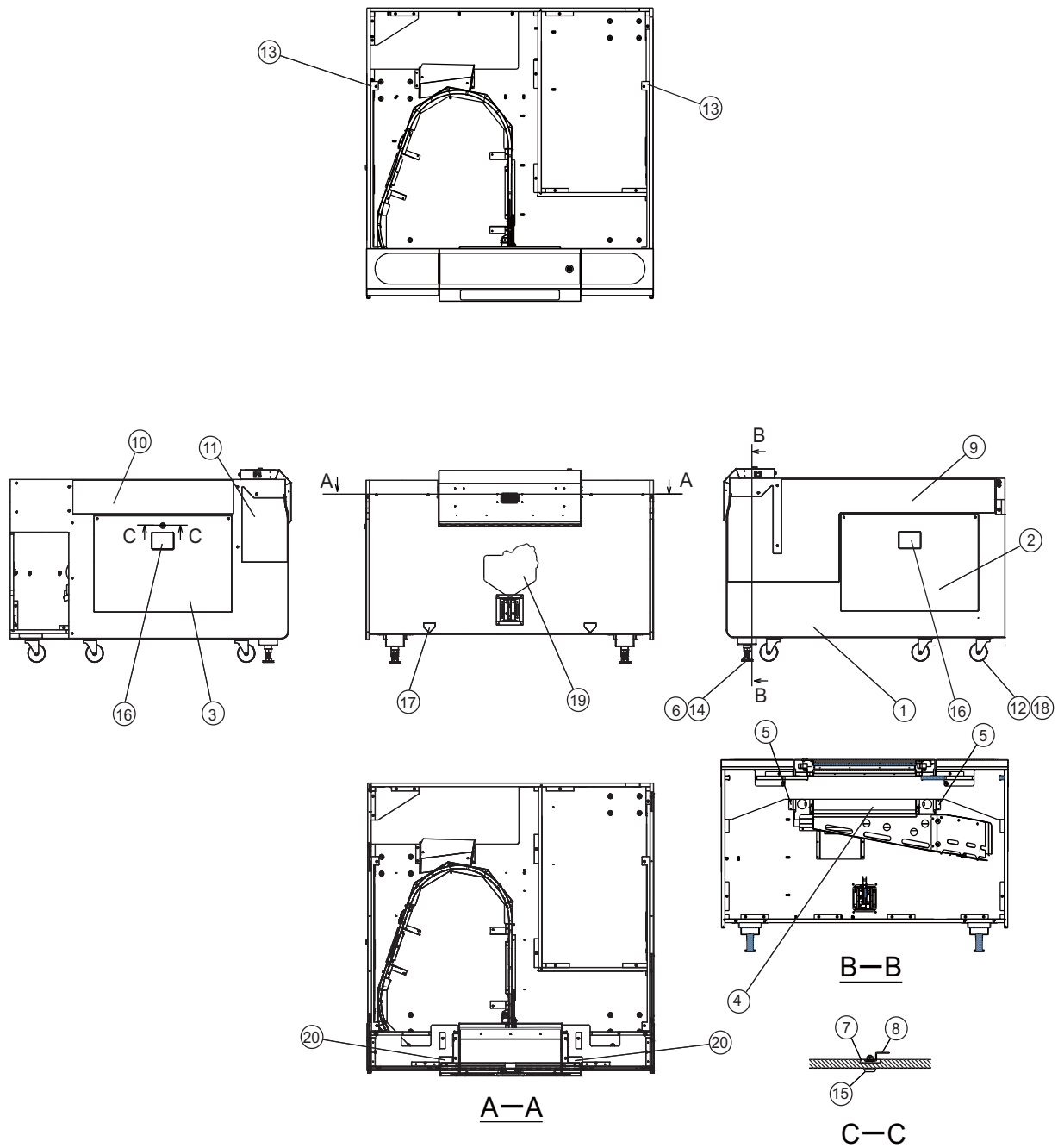

No.	Name	Qty.	Type and rating	Part No.
1	Table cabinet (L)	1		742-360
2	Front door	1		742-361
3	Service door	1		742-290
4	Goal set bracket	1		742-291
5	Goal set guide	2		742-344
6	Adjuster bracket	2		742-281
7	Key washer	1		731-453
8	Key plate	1		731-646
9	Cabinet sticker A2(EXP)	1		742-362

- 1
- 2
- 3
- 4
- 5
- 6
- 7
- 8A
- 8B
- 9
- 10
- 11
- 12

Table top assembly / Cabinet (L) assembly

Test Mode

Troubleshoot-

10. Parts List

10	Cabinet sticker B1(U)(EXP)	1		742-363
11	Cabinet sticker B1(L)(EXP)	1		742-364
12	Caster bracket	4		742-293
13	Air chamber bracket	2		742-284
14	Leveling bolt	2	M16X91L	102-297
15	COIN LOCK	1	N5008	741-715
16	Warning sticker Service (B) EXP	2		461-539
17	Fork sticker	2		742-285
18	Caster (swivel type)	4		102-295
19	L outlet sticker(EXP)	1		742-623
20	Warning sticker P(EXP)	2		742-622

10-4 Goal (L) assembly

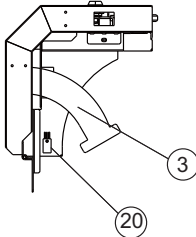
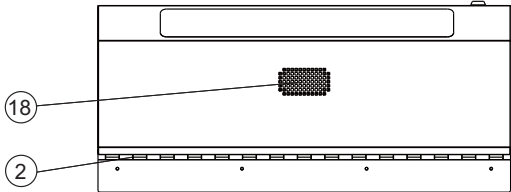
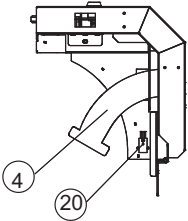
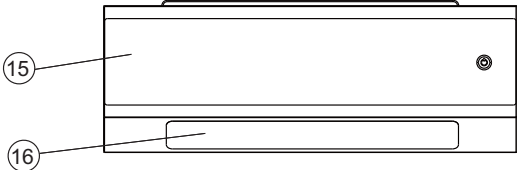
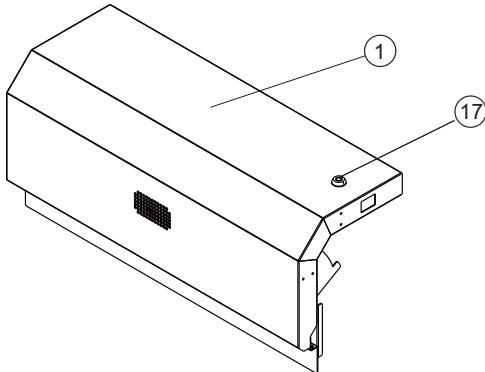

- 1
- 2
- 3
- 4
- 5
- 6
- 7
- 8A
- 8B
- 9
- 10**
- 11
- 12

Cabinet (L) assembly / Goal (L) assembly

Test Mode

Troubleshoot-

10. Parts List

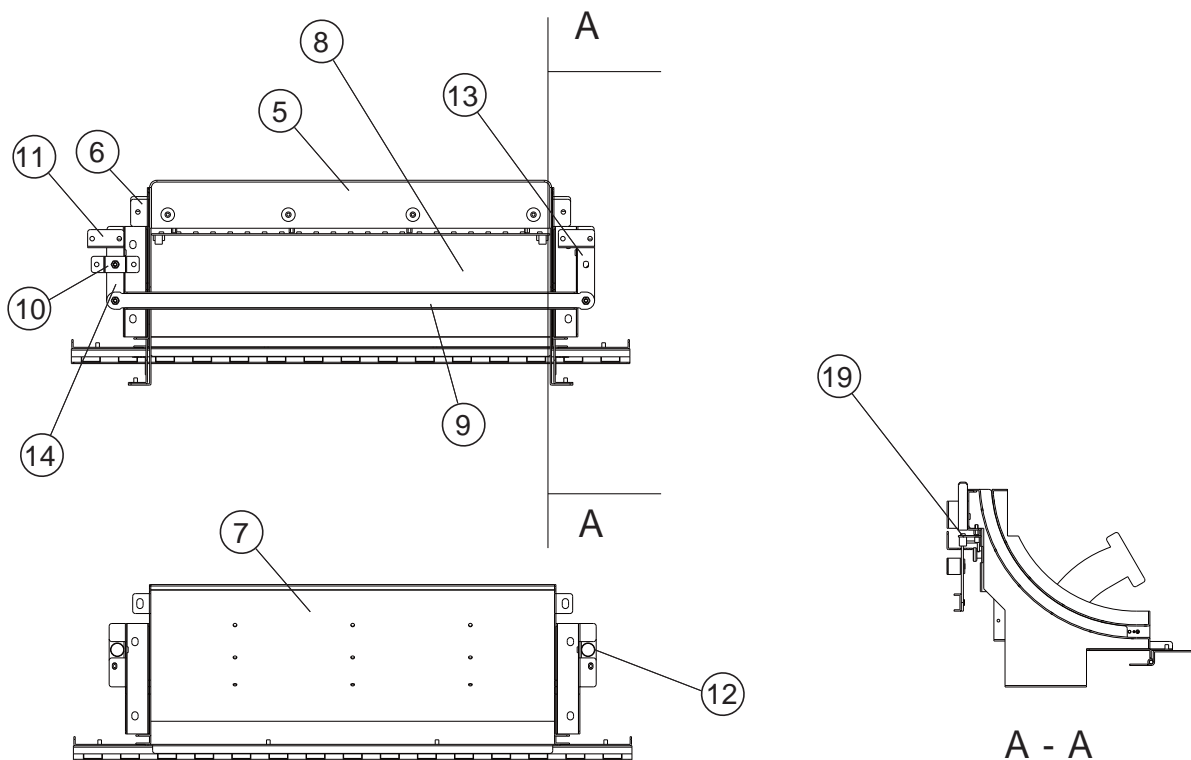

No.	Name	Qty.	Type and rating	Part No.
1	Goal cover	1		742-340
2	Goal cover hinge	1		742-341
3	Stopper R	1		742-342
4	Stopper L	1		742-343
5	Illumination plate	1		742-345
6	Illumination plate bracket	1		742-346
7	Goal inner	1		742-347
8	Goal outer	1		742-348
9	Link arm	1		742-349
10	Link base	1		742-350
11	Link stopper	2		742-351
12	Goal stopper	2		742-352
13	Lock Lever (R)	1		742-353
14	Lock Lever (L)	1		742-354
15	Instruction sticker EXP (pink)	1		742-365
16	Warning sticker Goal (EXP)	1		461-851
17	COIN LOCK	1	N5008	741-715
18	Speaker 8Ω10W	1	TV-5090FCA-R(Rohs)	006-212
19	Goal Illumination LED PC Board	1		742-453
20	Photo-Interrupter(detector/emitter)	1	KB892-AA22LF+AA12LF	000-954

10-5 Rail (L) assembly

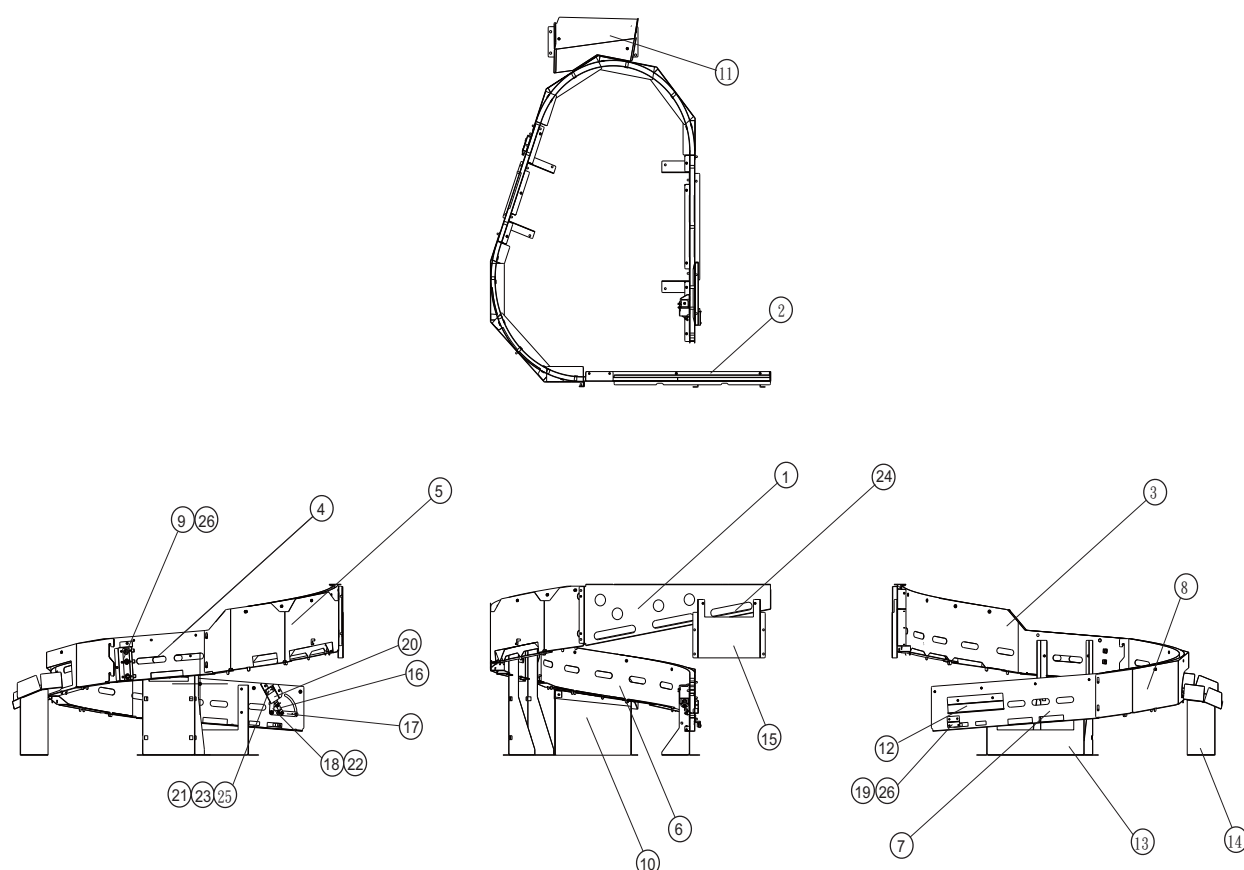

No.	Name	Qty.	Type and rating	Part No.
1	Goal outer lower (L)	1		742-370
2	Goal inner lower (L)	1		742-371
3	Corner inner (L)	1		742-372
4	Corner outer (L)	1		742-373
5	Corner bracket1 (L)	1		742-374
6	Rail inner (L)	1		742-375
7	Rail outer (L)	1		742-376
8	Rail center (L)	1		742-377
9	Rail sensor bracket (L)	1		742-378
10	Hopper slope (L) base	1		742-379
11	Hopper slope (L)	1		742-380
12	Puck guide	1		742-311
13	Rail base A	1		742-312
14	Rail base B	1		742-313
15	Rail base C	1		742-314
16	Link A	1		742-315
17	Link B	1		742-316
18	Link C	1		742-317
19	Photo sensor bracket	1		742-256

1

2

3

4

5

6

7

8A

8B

9

10

11

12

Goal (L) assembly / Rail (L) assembly

Test Mode

Troubleshoot-

10. Parts List

20	L outlet solenoid base(R)	1		742-381
21	Link shaft	1		742-319
22	Bush	2		742-320
23	Solenoid spring	1		742-321
24	Cushioning rubber	2		742-322
25	Shaking unit	1	SH-1039-12V	004-781
26	Reflective-type photo-interrupter	4	GP2A25J0000F	000-674

10-6 Cabinet (R) assembly

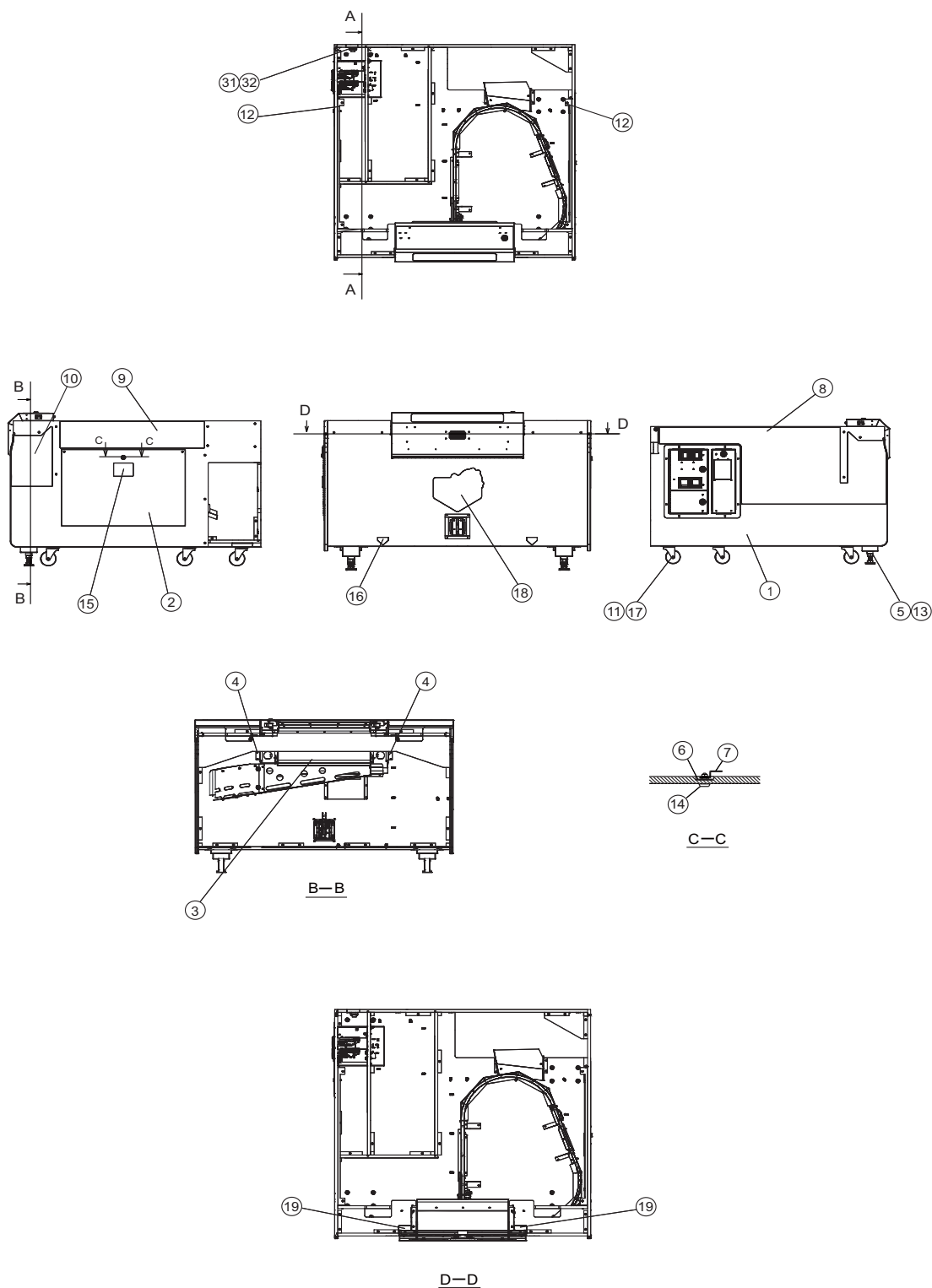

- 1
- 2
- 3
- 4
- 5
- 6
- 7
- 8A
- 8B
- 9
- 10
- 11
- 12

Rail (L) assembly / Cabinet (R) assembly

Test Mode

Troubleshoot-

10. Parts List

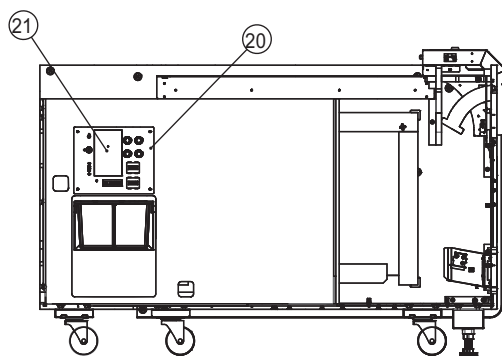

A - A

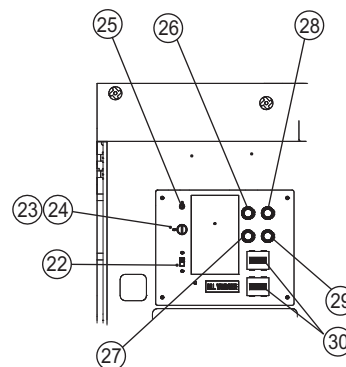

Detailed view of Service panel

No.	Name	Qty.	Type and rating	Part No.
1	Table cabinet (R)	1		742-280
2	Service door	1		742-290
3	Goal set bracket	1		742-291
4	Goal set guide	2		742-344
5	Adjuster bracket	2		742-281
6	Key washer	1		731-453
7	Key plate	1		731-646
8	Cabinet sticker A1(EXP)	1		742-286
9	Cabinet sticker B2(U)(EXP)	1		742-287
10	Cabinet sticker B2(L)(EXP)	1		742-288
11	Caster bracket	4		742-293
12	Air chamber bracket	2		742-284
13	Leveling bolt	2		102-297
14	COIN LOCK	1	N5008	741-715
15	Warning sticker Service (B) EXP	1		461-539
16	Fork sticker	2		742-285
17	Caster (swivel type)	4		102-295
18	L outlet sticker(EXP)	1		742-623
19	Warning sticker P(EXP)	2		742-622
20	Service panel	1		742-292
21	Service ST(EXP)	1		731-734
22	Slide switch	1	P-218-10mm	000-953
23	Volume	1	24N1-B5K,L-15KC/CI	008-089
24	Volume knob	1	P/598A	008-088
25	Toggle switch	1	MS-500E-B	000-956
26	Push switch (red)	1	502B-2R	000-941
27	Push switch (green)	1	502B-2G	000-952
28	Push switch (yellow)	1	502B-2Y	000-750
29	Push switch (blue)	1	502B-2BL	000-951
30	Electromagnetic counter	2	OA-126CL	003-065
31	RM5 PC board bracket	1	(EU specifications)	742-625
32	RM5 PC board	1	(EU specifications)	100-526

10-7 Goal (R) assembly

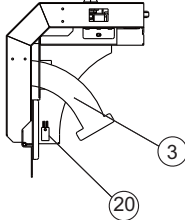
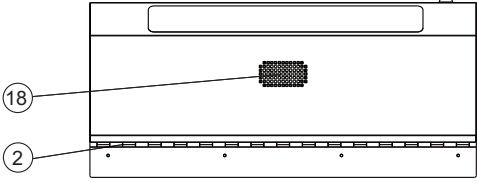
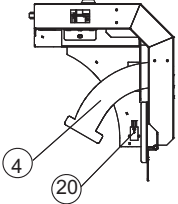
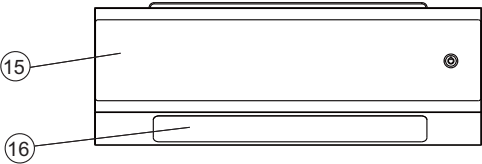
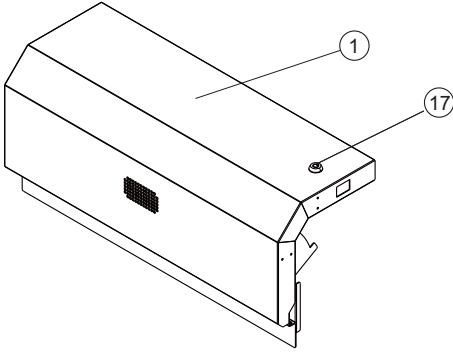

- 1
- 2
- 3
- 4
- 5
- 6
- 7
- 8A
- 8B
- 9
- 10**
- 11
- 12

Cabinet (R) assembly / Goal (R) assembly

Test Mode

Troubleshoot-

10. Parts List

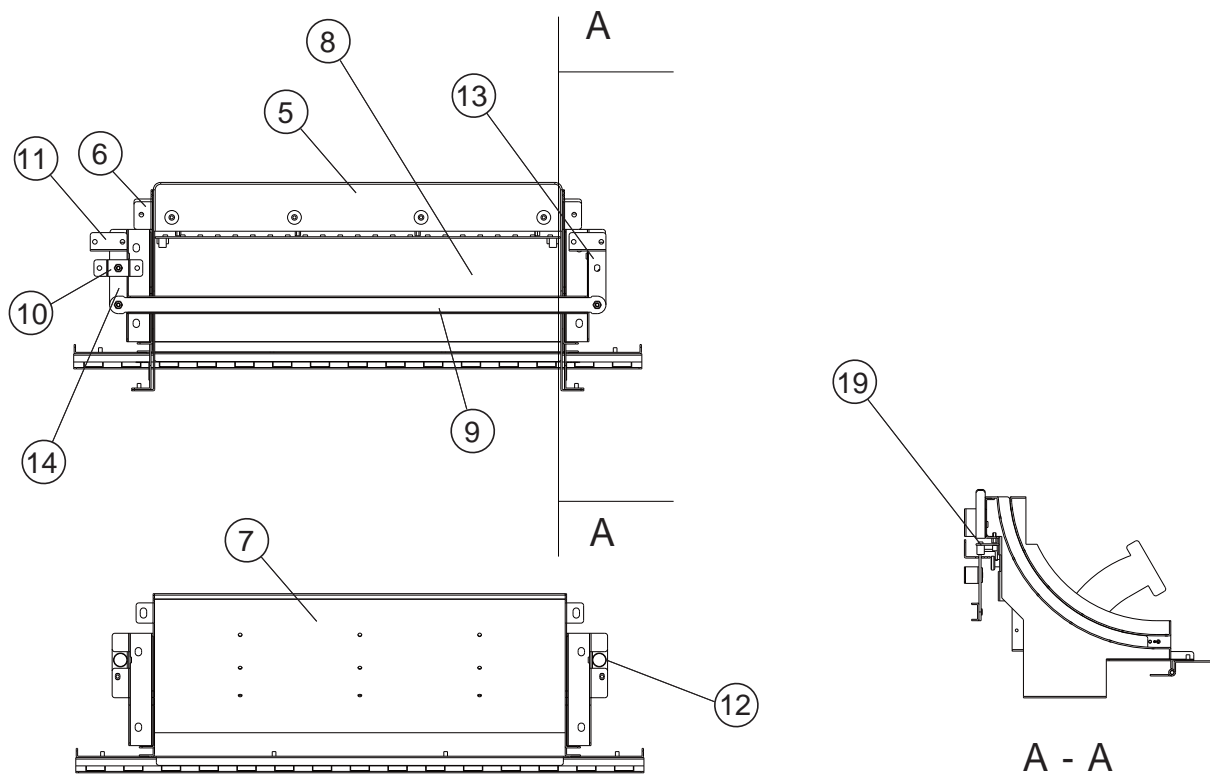

No.	Name	Qty.	Type and rating	Part No.
1	Goal cover	1		742-340
2	Goal cover hinge	1		742-341
3	Stopper R	1		742-342
4	Stopper L	1		742-343
5	Illumination plate	1		742-345
6	Illumination plate bracket	1		742-346
7	Goal inner	1		742-347
8	Goal outer	1		742-348
9	Link arm	1		742-349
10	Link base	1		742-350
11	Link stopper	2		742-351
12	Goal stopper	2		742-352
13	Lock Lever (R)	1		742-353
14	Lock Lever (L)	1		742-354
15	Instruction sticker (green) EXP	1		742-289
16	Warning sticker Goal (EXP)	1		461-851
17	COIN LOCK	1	N5008	741-715
18	Speaker	1	TV-5090FCA-R(Rohs)	006-212
19	Goal Illumination LED PC Board	1		742-453
20	Photo-Interrupter(detector/emitter)	1	KB892-AA22LF+AA12LF	000-954

10-8 Rail (R) assembly

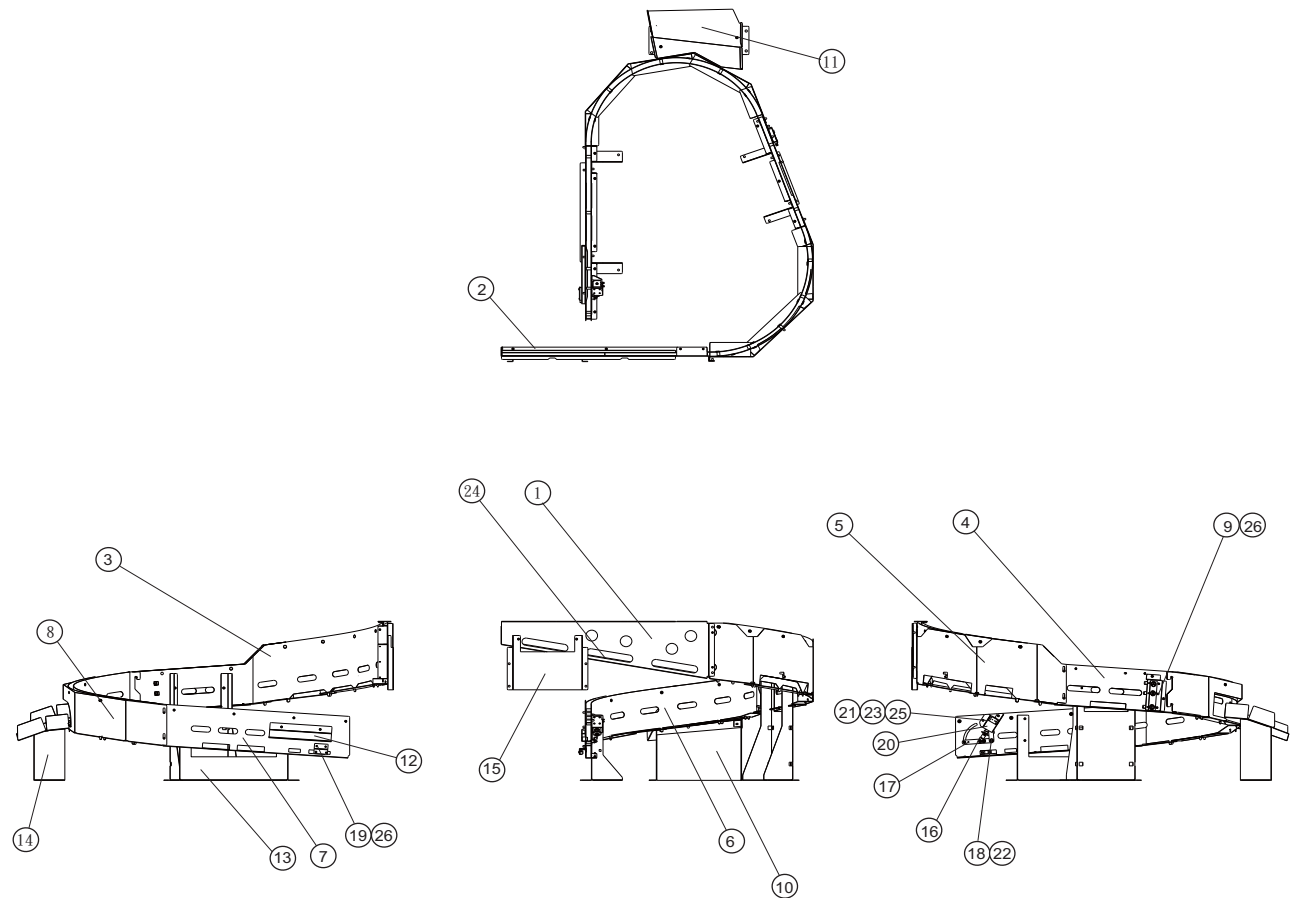

No.	Name	Qty.	Type and rating	Part No.
1	Goal outerlower (R)	1		742-300
2	Goal inner lower (R)	1		742-301
3	Corner inner (R)	1		742-302
4	Corner outer (R)	1		742-303
5	Corner bracket1 (R)	1		742-304
6	Rail inner (R)	1		742-305
7	Rail outer (R)	1		742-306
8	Rail center (R)	1		742-307
9	Rail sensor bracket (R)	1		742-308
10	Hopper slope (R) base	1		742-309

- 1
- 2
- 3
- 4
- 5
- 6
- 7
- 8A
- 8B
- 9
- 10
- 11
- 12

Goal (R) assembly / Rail (R) assembly

Test Mode
Troubleshoot-

10. Parts List

11	Hopper slope (R)	1		742-310
12	Puck guide	1		742-311
13	Rail base A	1		742-312
14	Rail base B	1		742-313
15	Rail base C	1		742-314
16	Link A	1		742-315
17	Link B	1		742-316
18	Link C	1		742-317
19	Photo sensor bracket	2		742-256
20	L outlet solenoid base(R)	1		742-318
21	Link shaft	1		742-319
22	Bush	2		742-320
23	Solenoid spring	1		742-321
24	Cushioning rubber	2		742-322
25	Shaking unit	1		004-781
26	Reflective-type photo-interrupter	4		000-674

10-9 Side tower assembly

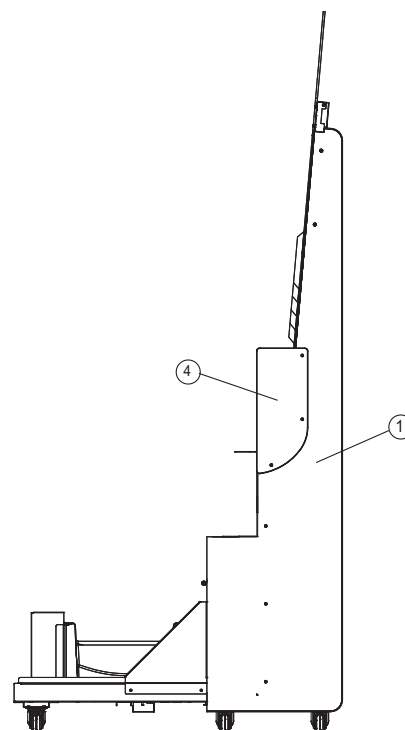
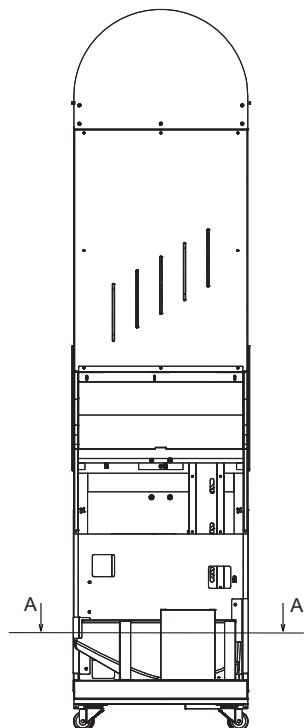

- 1
- 2
- 3
- 4
- 5
- 6
- 7
- 8A
- 8B
- 9
- 10**
- 11
- 12

Rail (R) assembly / Side tower assembly

Test Mode

Troubleshoot-

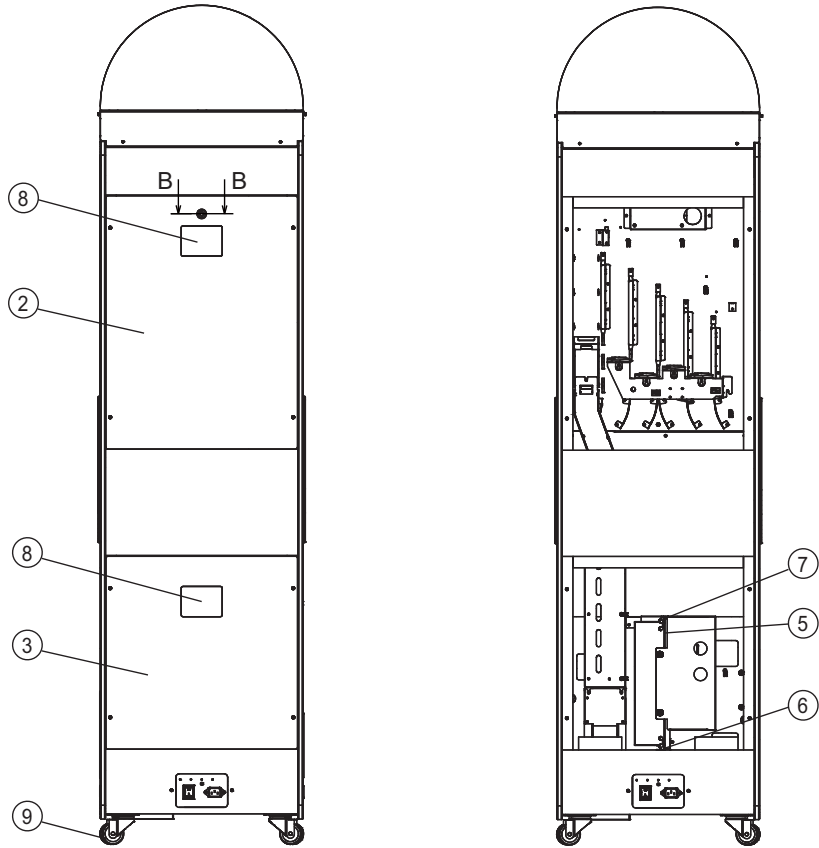

(When the Power supply cover is removed)

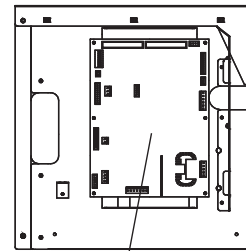
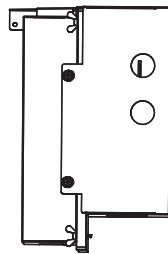
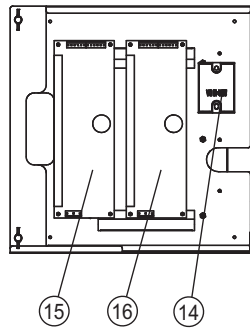

Main PC board

Detailed view of ⑤

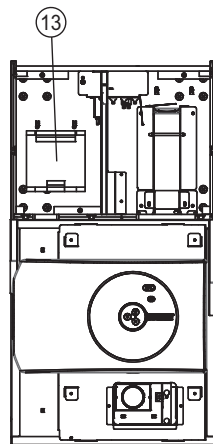

A-A

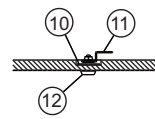

B-B

10. Parts List

No.	Name	Qty.	Type and rating	Part No.
1	Side tower cabinet	1		742-230
2	Rear panel	1		742-231
3	Service door	1		742-232
4	Side Wall	2		742-241
5	PC Board Base	1		742-242
6	PCB rail (L)	1		742-243
7	PCB rail (U)	1		742-244
8	Warning sticker Service B(EXP)	2		461-539
9	Castor(swivel type)	4		102-296
10	Key washer	1		731-453
11	Key plate B	1		731-452
12	COIN LOCK	1	N5008	741-715
13	Transformer	1		004-782
14	SSR	1	SSR S5C-215LV (5V 15mA)	004-783
15	Switching regulator (12 V)	1	LPP-150-12V	009-298
16	Switching regulator (24 V)	1	LPP-150-22V	009-299

1

2

3

4

5

6

7

8A

8B

9

10

11

12

Side tower assembly

Test Mode

Troubleshoot-

10-10 S hopper assembly

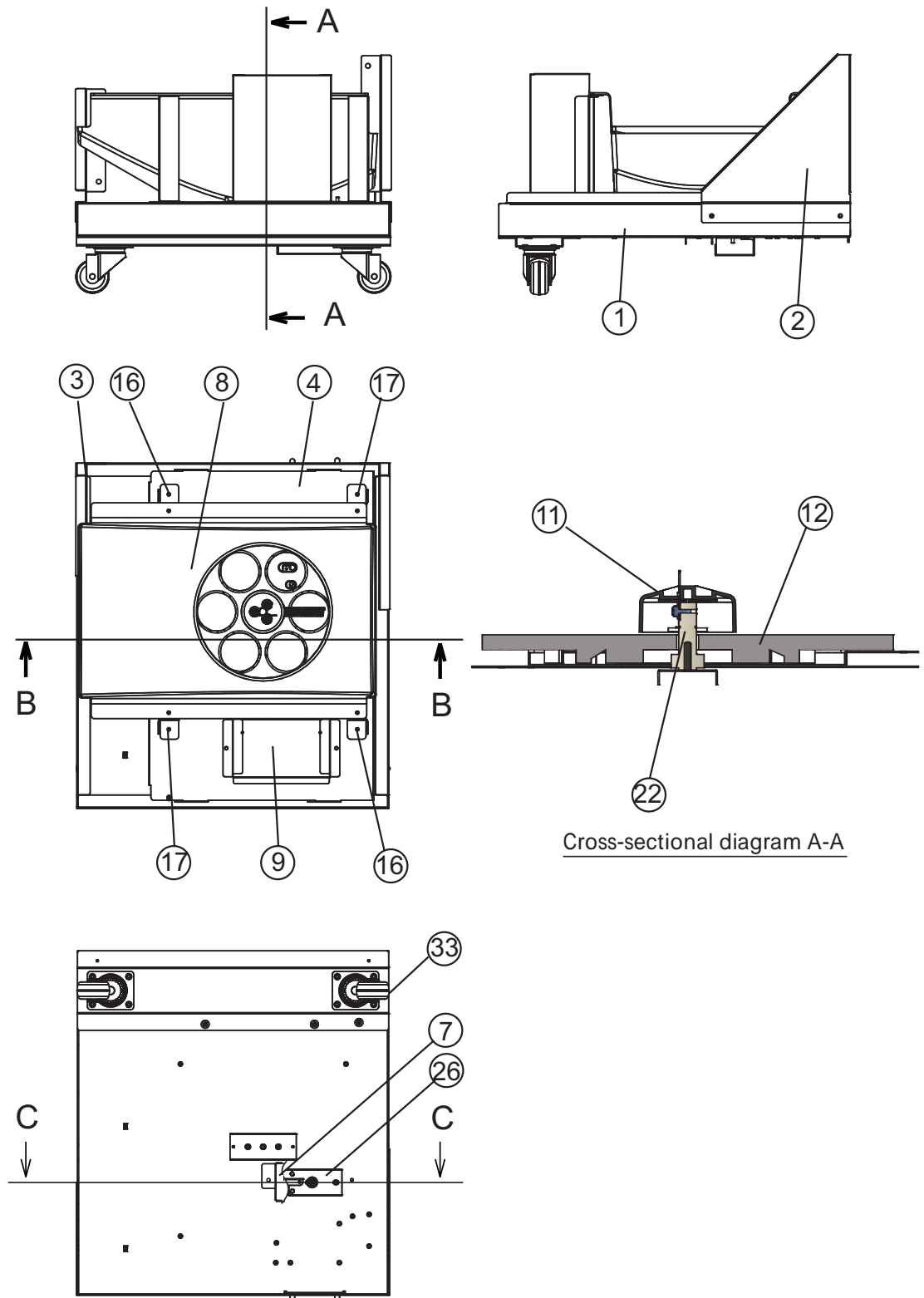

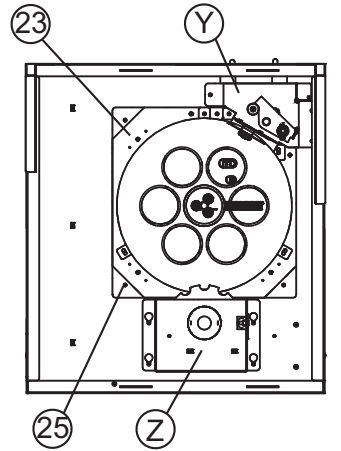

Condition with 4 removed

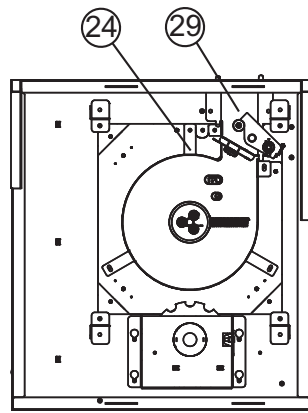

Condition with 4, 12, Y removed

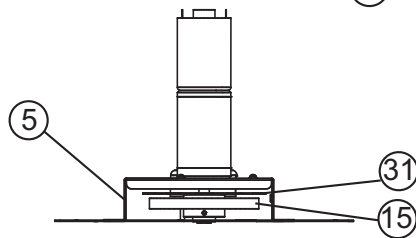
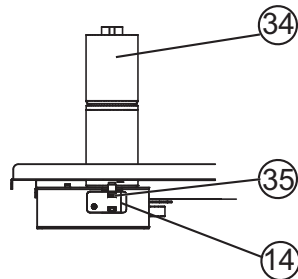

Detailed view of part Z

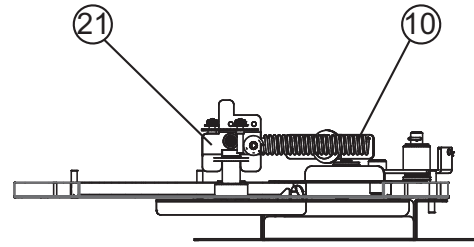

Cross-sectional diagram B-B
(Condition with 11 removed)

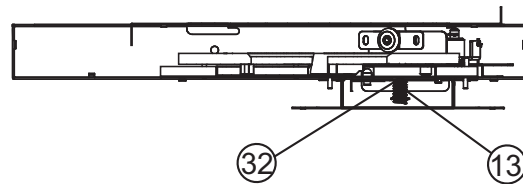

Cross-sectional diagram C-C

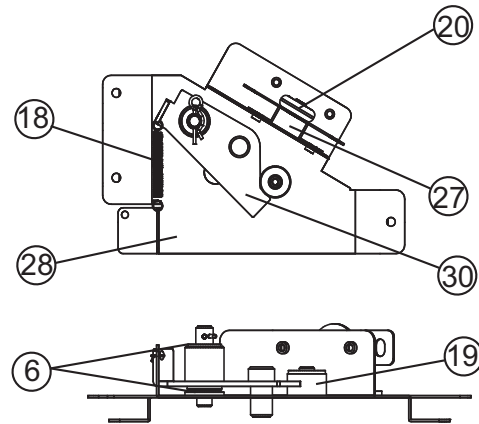

Detailed view of part Y

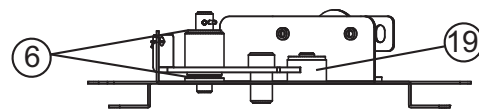

- 1
- 2
- 3
- 4
- 5
- 6
- 7
- 8A
- 8B
- 9
- 10
- 11
- 12

S Hopper assembly

Test Mode

Troubleshoot-

10. Parts List

No.	Name	Qty.	Type and rating	Part No.
1	Hopper base	1		742-270
2	Side plate (R)	1		742-271
3	Side plate (L)	1		742-272
4	Hopper cover	1		742-273
5	Hopper motor bracket	1		742-274
6	Flange bush	2		742-275
7	Guide pin cover	1		742-276
8	S bucket	1		742-277
9	Motor cover	1		742-278
10	Hopper spring	1		731-498
11	Disk top	1		731-481
12	S hopper disk	1		731-480
13	Guide pin spring	1		731-486
14	Encoder bracket	1		731-475
15	S hopper gear	1		731-490
16	S Bucket base A	2		731-472
17	S Bucket base B	2		731-473
18	Latch spring	1		731-476
19	Latch Stopper rubber	1		731-482
20	Roller	1		731-494
21	Hopper spring base	1		731-487
22	Disk shaft	1		731-488
23	S hopper under	1		731-461
24	S hopper puck guide	1		731-463
25	S hopper bottom	1		731-457
26	guide pin S	1		731-491
27	Disk retainer bracket	1		731-493
28	S hopper latch base	1		731-465
29	S hopper exit	1		731-484
30	S hopper latch	1		731-469
31	Encoder disk	1		731-474
32	S washer	1		731-497
33	Castor (swivel type)	2		102-296
34	Geared DC motor	1	IG520066_DC24V	005-588
35	Transmissive-type Photo-interrupter	1	GP1A173LCS2F	000-887

10-11 Slider assembly

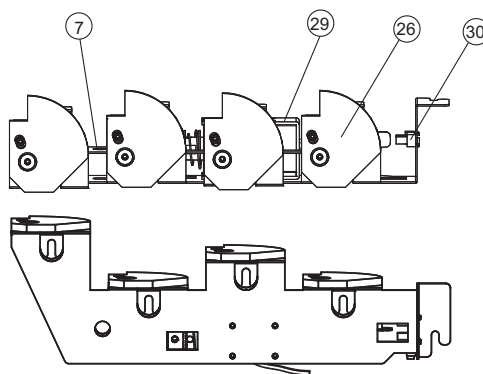
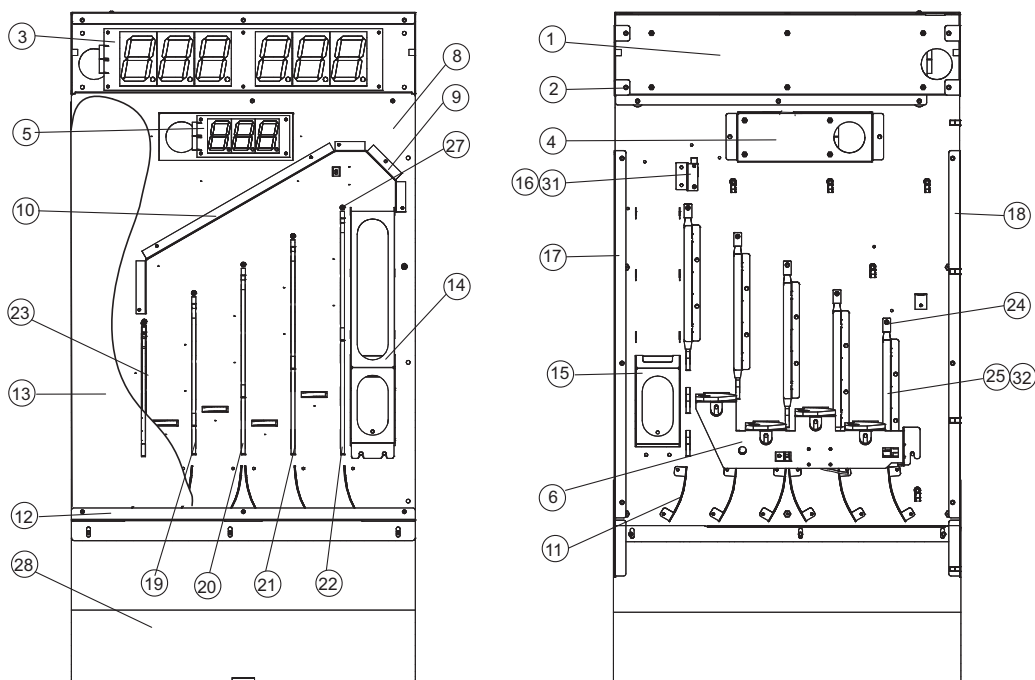

- 1
- 2
- 3
- 4
- 5
- 6
- 7
- 8A
- 8B
- 9
- 10**
- 11
- 12

S Hopper assembly / Slider assembly

Test Mode

Troubleshoot-

10. Parts List

No.	Name	Qty.	Type and rating	Part No.
1	Score LED base	1		742-234
2	Bracket A	2		742-235
3	Score LED PC board	1		742-451
4	Time LED base	1		742-236
5	Time LED PC board	1		742-452
6	S stopper base	1		742-245
7	S stopper link	1		742-246
8	Slider base	1		742-247
9	Slide guide A	1		742-248
10	Slide guide B	1		742-249
11	Guide rail	6		742-250
12	Cover panel retainer	1		742-251
13	Cover panel (EXP)	1		742-252
14	Slider Rail cover	1		742-254
15	Slider Rail (L)	1		742-255
16	Photo sensor bracket	1		742-256
17	Slider base bracket (R)	1		742-257
18	Slider base bracket (L)	1		742-258
19	Guide A	1		742-259
20	Guide B	1		742-260
21	Guide C	1		742-261
22	Guide D	1		742-262
23	Slider LED plate	5		742-263
24	Slider guide fixed plate	5		742-264
25	Slider guide	5		742-265
26	Stopper L	4		731-517
27	Entrance pin T	5		731-534
28	Slope(EXP)	1		742-423
29	Shaking unit	1		004-780
30	Transmissive-type Photo-interrupter	1	GP1A173LCS2F	000-887
31	Refective-type photo-interrupter	1	GP2A25J0000F	000-674
32	Tape LED	5	SMD5054	002-783

10-12 S escalator assembly

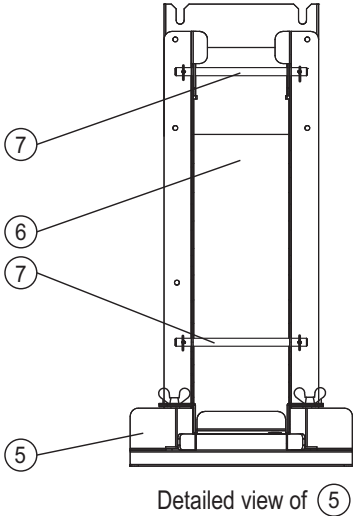
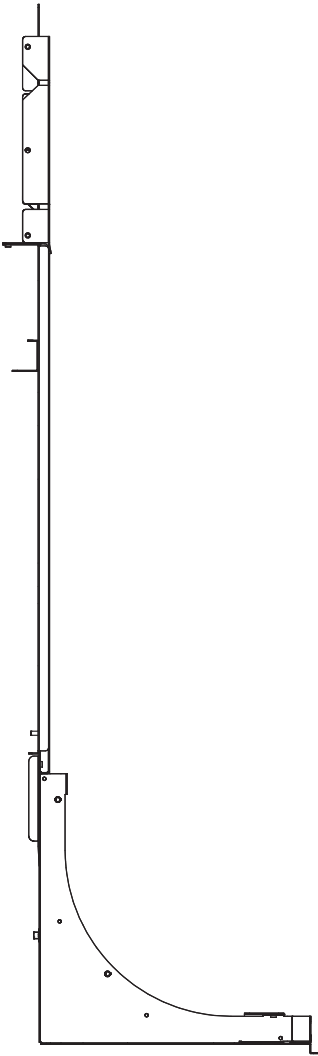
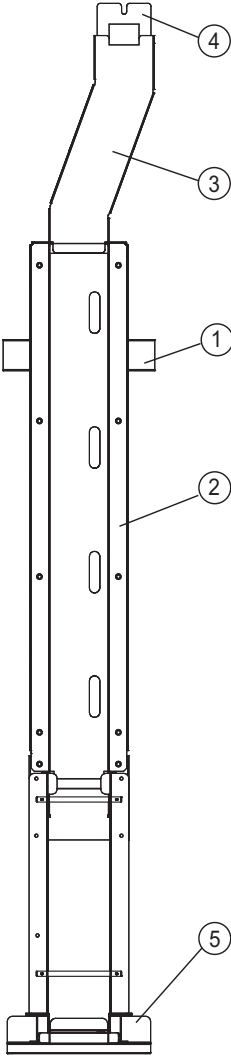

Detailed view of 5

- 1
- 2
- 3
- 4
- 5
- 6
- 7
- 8A
- 8B
- 9
- 10**
- 11
- 12

Slider assembly / S escalator assembly

Test Mode

Troubleshoot-

10. Parts List

No.	Name	Qty.	Type and rating	Part No.
1	S rail cover (L)	1		742-237
2	S rail (L)	1		742-238
3	S rail (U)	1		742-239
4	S rail cover (U)	1		742-240
5	S rail(R)	1		731-540
6	S rail (R) lid	1		731-550
7	Lid pin S	2		731-551

10-13 Coin cabinet assembly

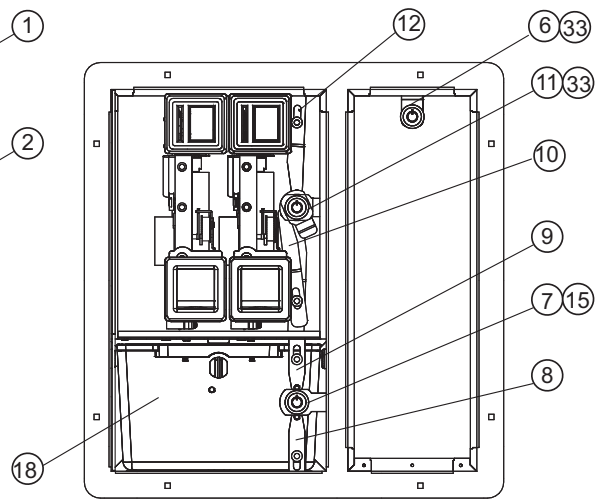
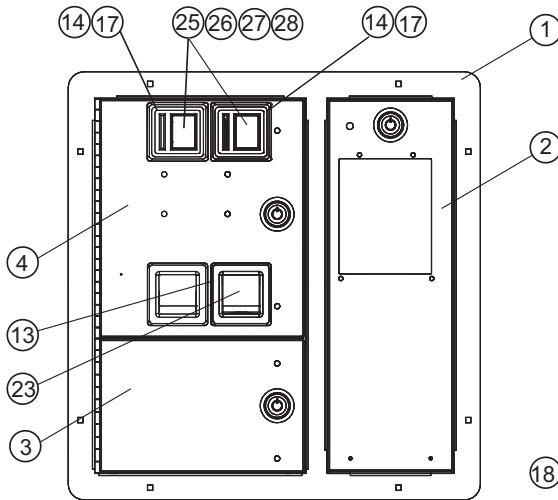
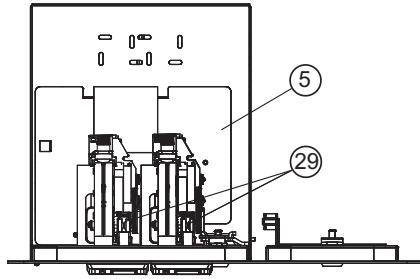

* 2 Way are U.S. only the specification

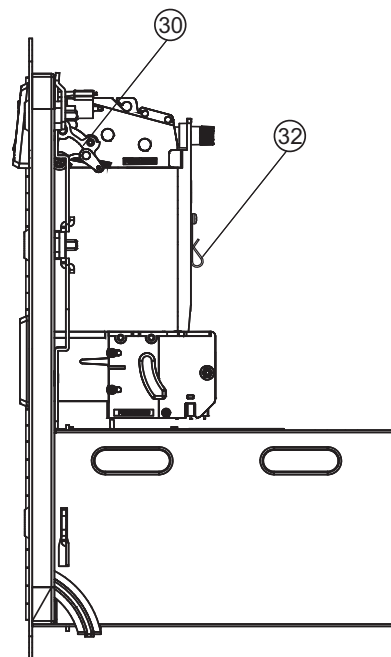
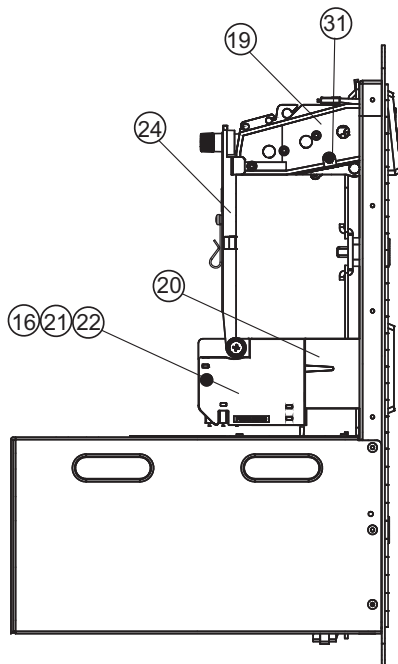

- 1
- 2
- 3
- 4
- 5
- 6
- 7
- 8A
- 8B
- 9
- 10
- 11
- 12

Escalator assembly / Coin cabinet assembly

Test Mode

Troubleshoot-

10. Parts List

No.	Name	Qty.	Type and rating	Part No.
1	Coin cabinet	1		742-460
2	Bill Validator door	1		742-461
3	Coin door	1		742-462
4	Selector door(2way)	1		742-463
5	Cash box upper plate	1		742-465
6	Key hook(Bill Validator door)	1		742-466
7	Key hook A(Coin door)	1		742-467
8	Key hook B(Coin door)	1		742-468
9	Key hook C(Coin door)	1		742-469
10	Key hook A(Selector door)	1		742-470
11	Key hook B(Selector door)	1		742-471
12	Key hook C(Selector door)	1		742-472
13	Return bezel	1		742-473
14	Entry bezel	2		742-474
15	Coin lock	1		741-715
16	Micro switch	2		000-957
17	Spacer	16		742-478
18	Cash box	1		742-479
19	Coin slot	2		742-480
20	Coin return outlet	2		742-481
21	Switch cover	2		742-482
22	Switch cover plate	2		742-483
23	Return door flap	2		742-484
24	Selector plate	2		742-485
25	Reject button cover	2		742-486
26	Reject link plate	2		742-487
27	Reject lamp plate	2		742-488
28	blocker plate	2		742-489
29	LED lamp Assembly	2		742-490
30	Reject lever	2		742-491
31	Spring	2		742-493
32	Spring pin	2		742-494
33	Coin lock	2	N5008	741-715
34	Coin lock	1		741-715
35	Micro switch	2		000-957

10-14 Signboard assembly

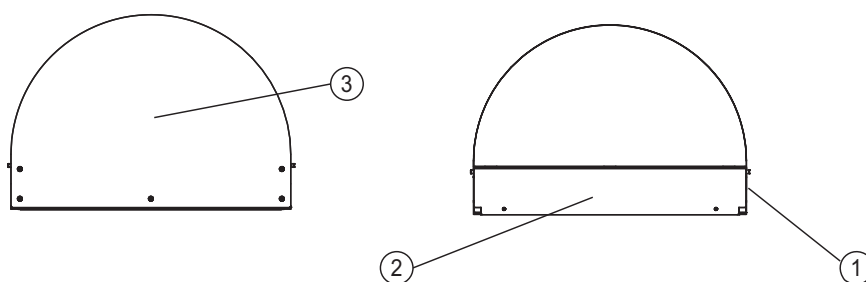

No.	Name	Qty.	Type and rating	Part No.
1	Signboard base	1		742-424
2	Signboard base cover	1		742-425
3	Signboard(EXP)	1		742-432

10-15 Cord box assembly

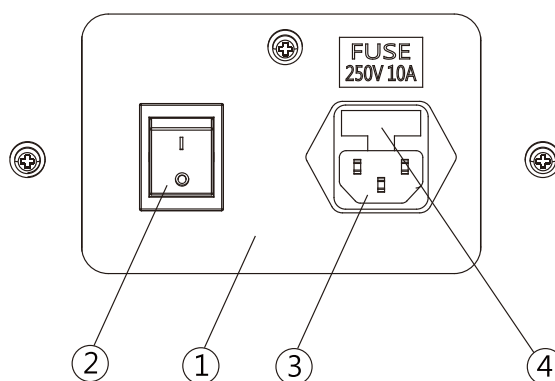

No.	Name	Qty.	Type and rating	Part No.
1	Cord box	1		742-253
2	Power switch	1	JS-608-RAL-0-R/B-2-2V/VDE	000-950
3	Noise filter	1	YL10T1	011-284
4	Mini fuse	1	10A Φ 5×20mm	742-626

1

2

3

4

5

6

7

8A

8B

9

10

11

12

Coin cabinet assembly / Sign board assembly / Cord box assembly

Test Mode

Troubleshoot-

10-16 L outlet assembly

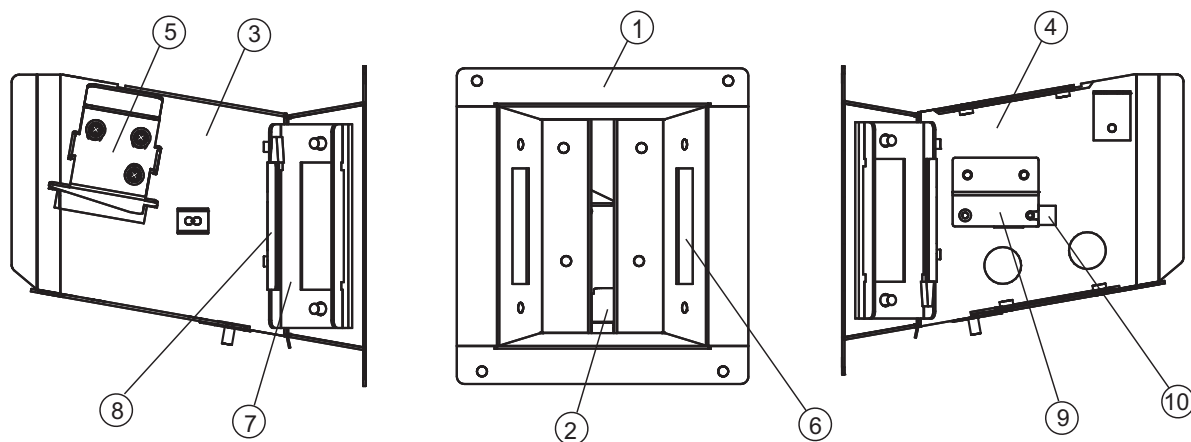

No.	Name	Qty.	Type and rating	Part No.
1	L outlet panel	2		742-330
2	L outlet stopper	2		742-331
3	L outlet rail cover	2		742-332
4	L outlet rail	2		742-333
5	Pendulum stopper	2		742-334
6	L outlet LED cover	4		742-335
7	L outlet LED bracket	4		742-336
8	Tape LED	4		002-782
9	Photo sensor bracket	2		742-256
10	Refl active-type photo-interrupter	2	GP2A25J0000F	000-674

10-17 Light assembly

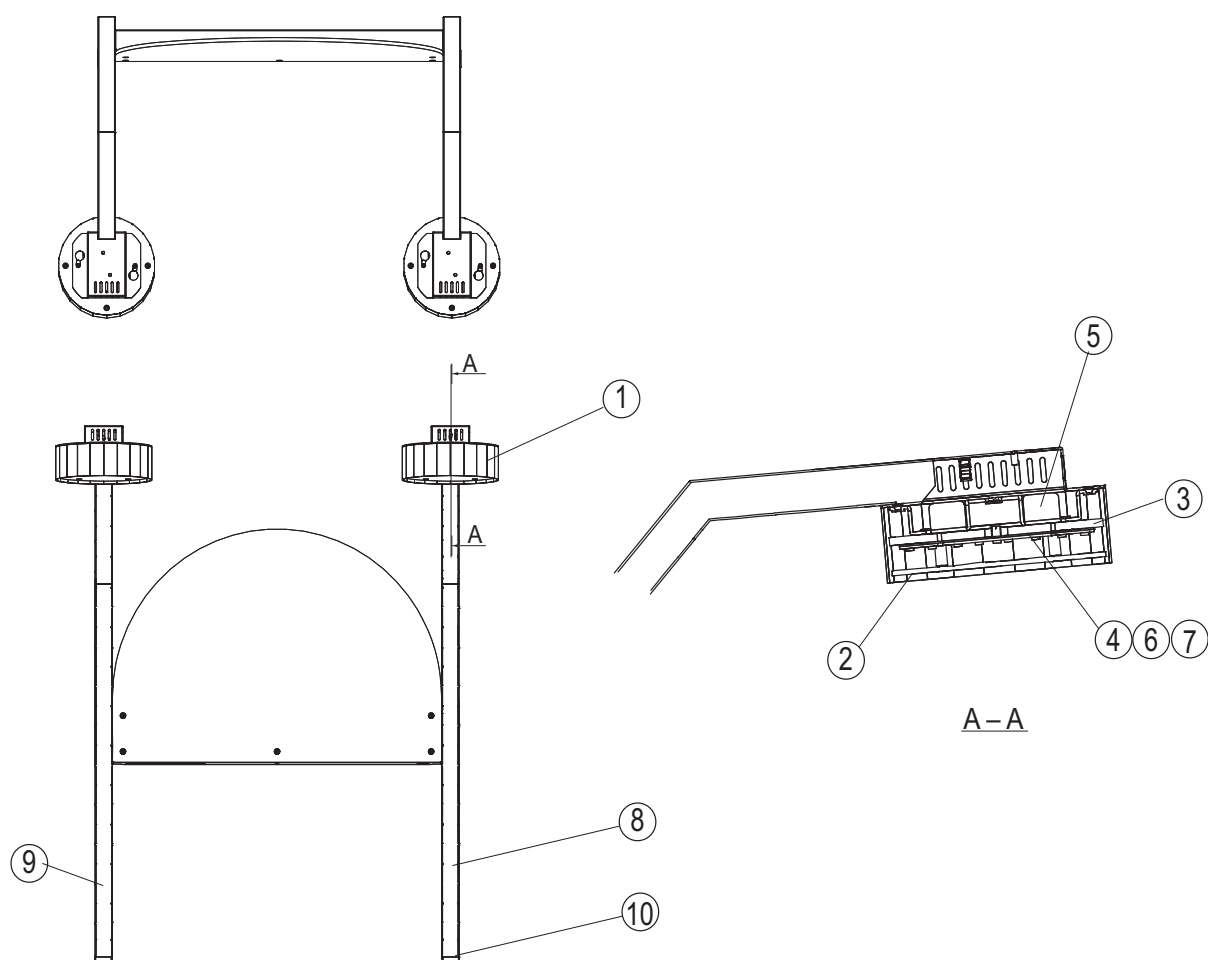

No.	Name	Qty.	Type and rating	Part No.
1	Light frame	2		742-426
2	Light cover	2		742-427
3	Light bracket	2		742-428
4	LED light pc board	2		742-454
5	Cooling plate	2		742-429
6	Bush	8		742-430
7	Thermal conducting sheet	2		742-431
8	Light arm (R)	1		742-433
9	Light arm (L)	1		742-434
10	Pipe cap	2		742-435

- 1
- 2
- 3
- 4
- 5
- 6
- 7
- 8A
- 8B
- 9
- 10
- 11
- 12

L outlet assembly / Light assembly

Test Mode

Troubleshoot-

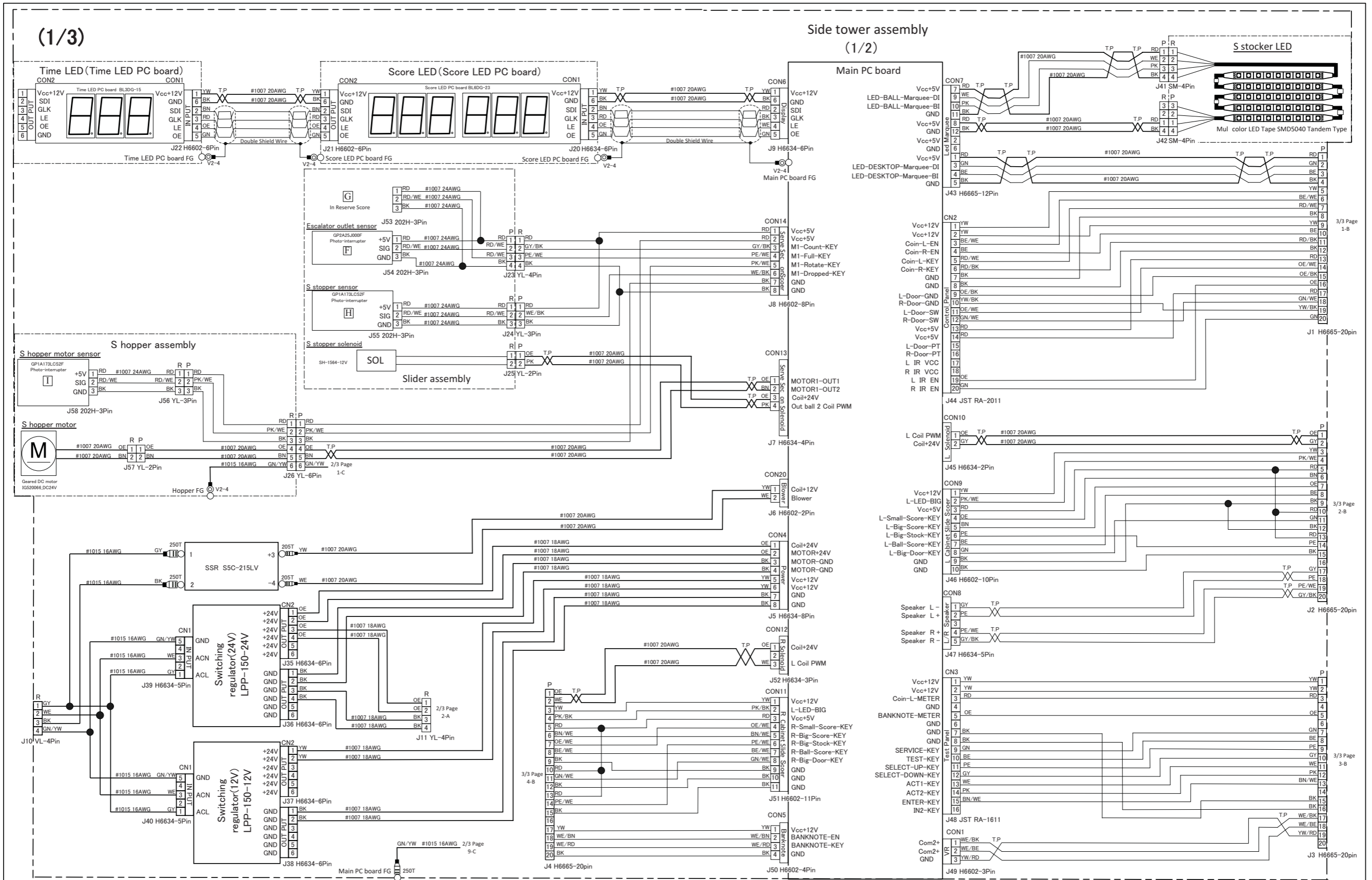

BK	BLACK	OE	ORANGE	BE	BLUE	WE	WHITE
BN	BROWN	YW	YELLOW	PE	PURPLE	PK	PINK
RD	RED	GN	GREEN	GY	GRAY		

- 1
 - 2
 - 3
 - 4
 - 5
 - 6
 - 7
 - 8A
 - 8B
 - 9
 - 10
 - 11
 - 12
- Wiring Diagram
- Test Mode
- Troubleshooting

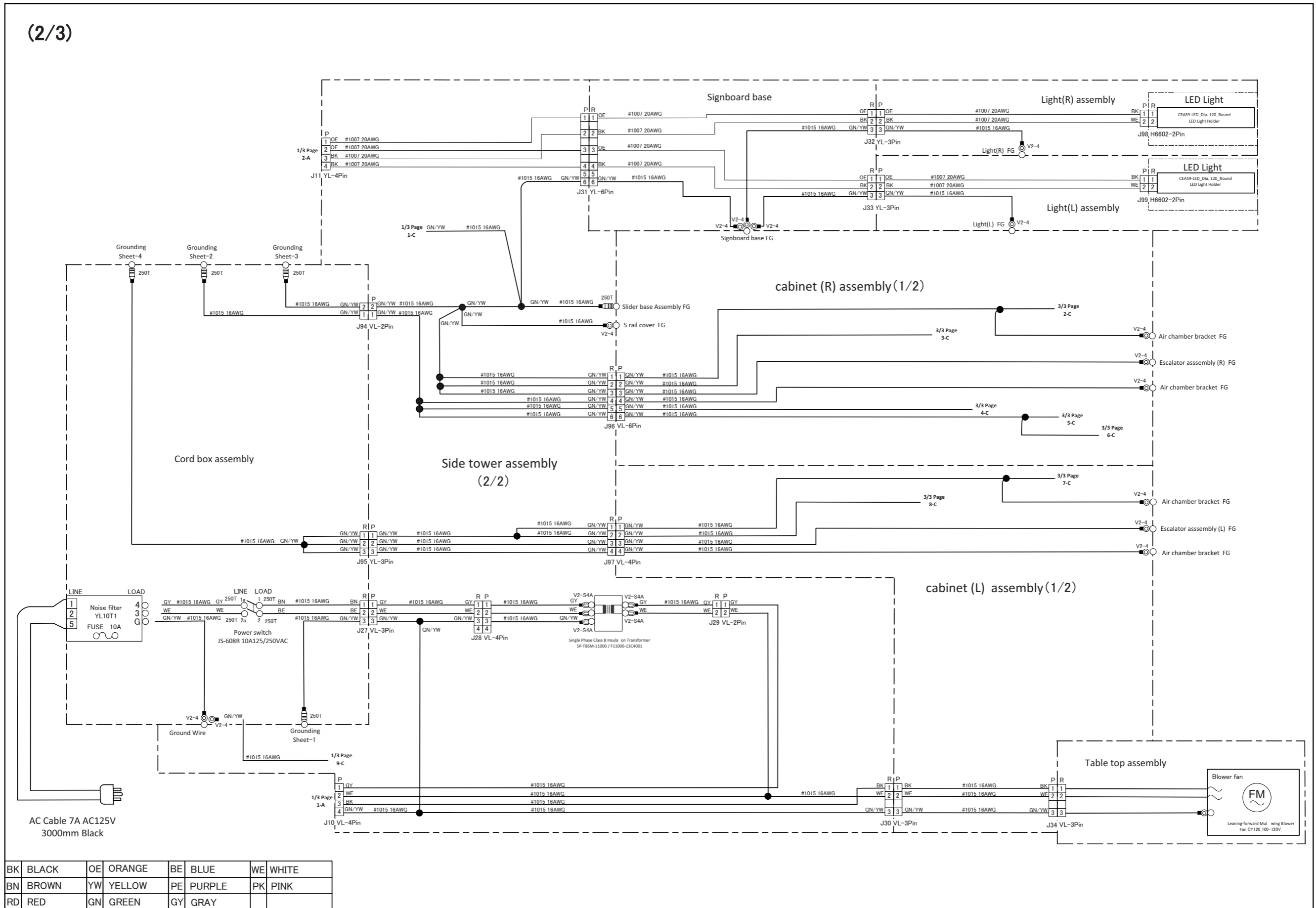

BK	BLACK	OE	ORANGE	BE	BLUE	WE	WHITE
BN	BROWN	YW	YELLOW	PE	PURPLE	PK	PINK
RD	RED	GN	GREEN	GY	GRAY		

- 1
- 2
- 3
- 4
- 5
- 6
- 7
- 8A
- 8B
- 9
- 10
- 11
- 12

Wiring Diagram

Test Mode

Troubleshooting

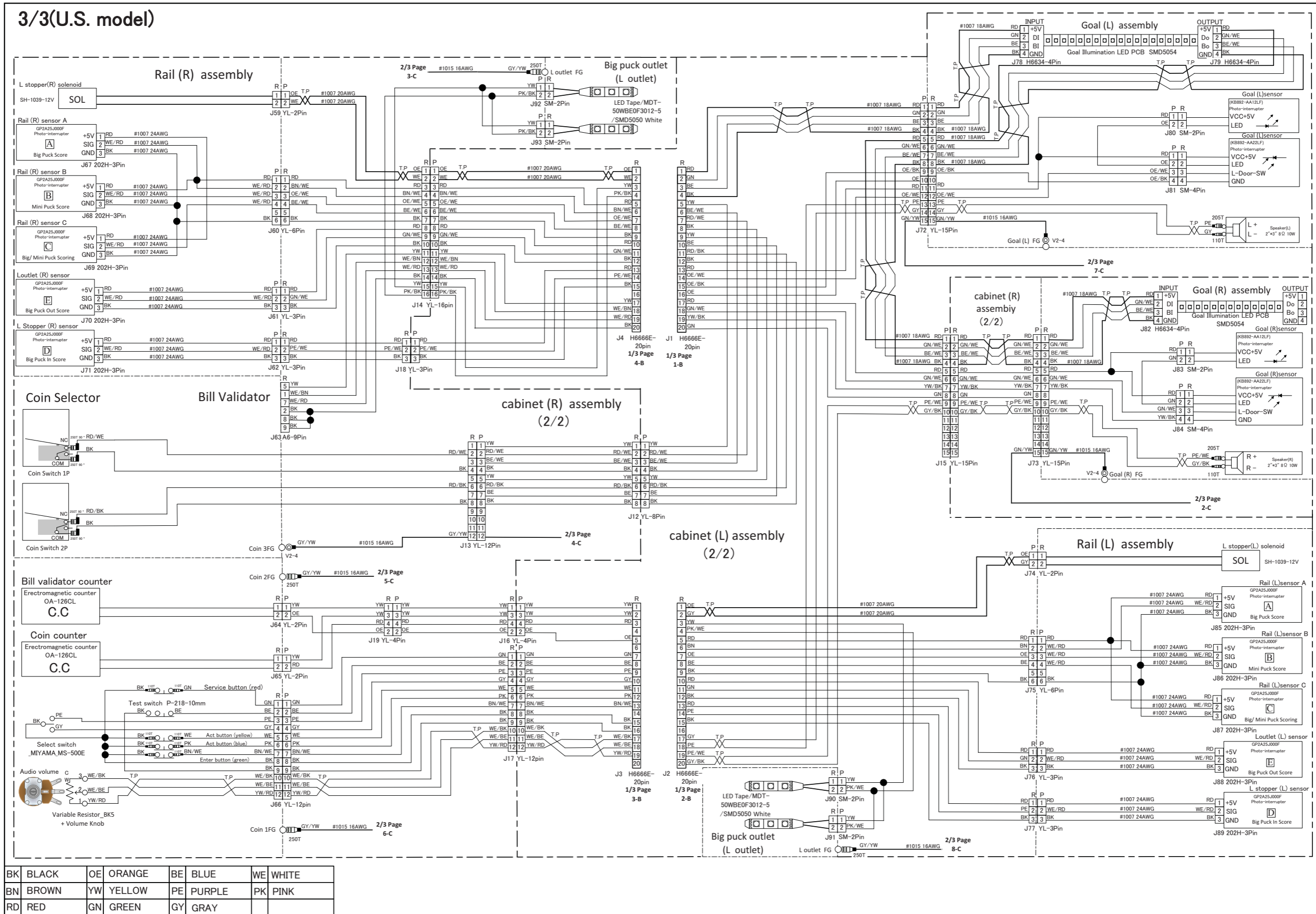

- 1
- 2
- 3
- 4
- 5
- 6
- 7
- 8A
- 8B
- 9
- 10
- 11
- 12
- Wiring Diagram
- Test Mode
- Troubleshooting

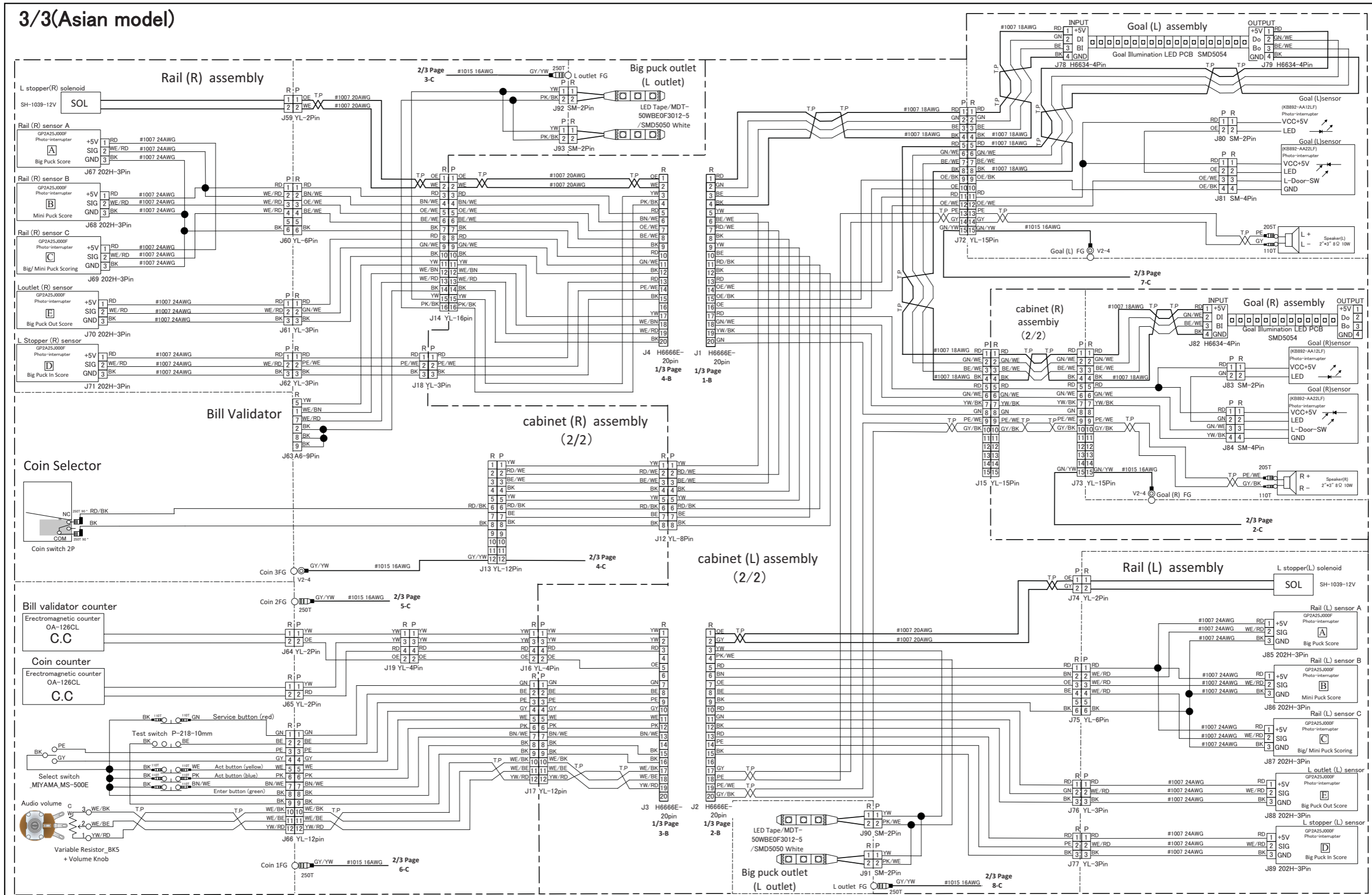

- 1
- 2
- 3
- 4
- 5
- 6
- 7
- 8A
- 8B
- 9
- 10
- 11
- 12
- Wiring Diagram
- Test Mode
- Troubleshooting

- 1
- 2
- 3
- 4
- 5
- 6
- 7
- 8A
- 8B
- 9
- 10
- 11
- 12
- Wiring Diagram
- Test Mode
- Troubleshooting

3/3(European model)

