

KIDDIE RIDES



OPERATORS MANUAL

NOO-NOO

INITIAL INSPECTION

Upon arrival of the machine check for any signs of damage to the packing or ride. Any damage should be reported to your supplier immediately. Check the mains supply voltage and coin mechanism are correct.

INITIAL OPERATION

1. Prior to operating the ride read the instruction manual
2. Ensure the mains supply stated on the rides serial number plate prior to connection. Connect the machine to a mains supply.
3. Upon connection of supply the ride lights (if fitted) will flash. Insert a coin (or however many coins the ride is set for) and the ride should operate. Sound should work. Ride will operate for a pre set period (normally 60 seconds) then stop. Some machines are fitted with a start button and will only start when the correct coinage is inserted and the start button pressed.
At the end of ride the machine will stop and the counter will have recorded 1 ride (or in the case of rides with multi mechanisms which give credits the counter will record coin base units).

PRIOR TO SITING THE RIDE

Before siting the ride make a note of the machines serial number. This is situated on the silver manufacturers plate at the rear of the machine. The serial number gives access to essential manufacturing details of your ride and is vital for the tracing of parts and manufacturing detail, and spares back-up.

SITING THE RIDE

The following conditions must be observed when siting the machine:-

1. The machine must be placed on level ground which is firm and free from holes etc. The surface that the machine stands on should not be slippery.
2. The ride is designed for protected locations. The ride should not be sited in any area where it would be subjected to water splash. The ride may be sited outdoors if under a canopy which will protect it from rain.
3. The machine should be connected to an RCB device.
4. The machine should be sited clear from any other obstruction. The manufacturer recommends the machine is sited a minimum of 1.8 metre from any other obstruction or equipment.
5. The power point that supplies the ride should be no further than 6 feet away and the cable must be safely secured and protected to eliminate any risk of damage or tripping.
6. The ride should not be sited in an area where it will cause an obstruction.
7. Always ensure that the mains plug is accessible so that mains power may be isolated in an emergency.

NORMAL OPERATION (FOR RIDE FITTED WITH MECHANICAL COIN MECHANISM)

We will assume 1 ride = 25c (Quarter)

1. Ensure volume knob is set to a high level
2. Connect ride to mains supply:-
Light should flash

FOR 1 RIDE

3. INSERT coin - coin should accept and the ride will start. Counter will turn 1 revolution.
4. After approximately one minute, ride will end.

To adjust ride time, volume and coins per ride, see Stamar 'Tiny Tunes' guide.

WARNING STICKERS

Amutec's rides are provided with comprehensive warning stickers and instructions which are applied to the ride at the time of sale. Operators should ensure:-

1. These stickers remain in place
2. Stickers remain clearly readable and undamaged
3. Stickers are translated into any commonly used local language and then applied to the machine

COPYRIGHT AND TRADEMARK NOTICES

It is a licensing requirement that these notices remain legible and permanently affixed to the ride.

INSPECTIONS

Every time the ride is emptied check:-

1. The mains cable and mains plug are in good condition ensuring the fuse is of the correct rating
2. All warning stickers or instruction stickers are in a clean undamaged condition
3. That no sharp edges have been caused by broken lenses or damaged fibreglass
4. Run the machine and check operation is correct

Every three months check:-

1. No items on the machine have come loose
2. There is no build up of rubbish in the base of the machine

EVERY YEAR CARRY OUT THE FOLLOWING INSPECTION PROCEDURE

MECHANICAL EXAMINATION

1. Remove inspection covers (where fitted) or sufficient casings so as to allow thorough examination of moving parts and any part of the structure which could conceivably be regarded as vital to the safe running of the ride. (Whenever fibreglass covers are dis-assembled, workwear gloves should be worn to protect from internal fibreglass raw edges)
2. Check that all bolts and nuts are tight and fitted with shake-proof or spring washers, where appropriate
3. Check that all bearings are in good condition and lubricated where necessary
4. Check that lubrication levels are correct where appropriate (in gearbox's supplied by Amutec this is not necessary)
5. Check that couplings, belts, chains and hydraulic rams are in good condition and in the case of hydraulic parts and pneumatic systems, ensure that all seals are secure. Check seals for leakage of hydraulic fluid or air as appropriate
6. Passenger restraints, where fitted, to be checked for effectiveness
7. When confident that all reasonable mechanical checks have been carried out, check for damage or weakness in casings and in the body of the ride

ELECTRICAL EXAMINATION

1. Check mains input lead for damage and that correct polarity has been observed. All covers should be removed and terminations checked for tightness and integrity. Any abrasions to sheath or insulation should be noted and cables renewed as required

2. Check that any fuses fitted are correct rating and type
3. Any metal parts of the machine such as the base, stem or metal parts attached thereto, which could possibly come into contact with, or have any connection to components which are supplied by mains voltage, should be securely earthed. All earth connections should be checked and the earth path to the furthest extreme of the machine manually checked. All such connections and terminations should be free of dirt and corrosion. Metal parts forming part of the SELV circuit, or completely remote from the possibility of contact with electrical parts, or induced currents, should not be earthed (see note 3)
4. Check to ensure good connections and freedom from damp and dirt on connectors, cable runs etc.
5. All components must be checked to ensure correct functioning and that no cracks or breakages have been sustained. In the case of lamps, that the correct wattage is fitted
6. Instrument test should be carried out to verify the comprehensive manual inspection. The test carried out should be:-
 - (a) EARTH CONTINUITY (bonding) to the requirements of IEE Regulations and Electricity at Work Regulations (that is in the case of children's coin operated rides 0.3 ohms max. at a test current of 25 amps
 - (b) INSULATION PROTECTION to the requirements of IEE Regulations and Electricity at Work Regulations (that is 2 megohm at a test voltage of 500-600 volts)

As a whole, electrical test envisaged includes a comprehensive visual examination, the instrument test can be regarded as absolute. Reference to the machine history is therefore not necessary (in most cases a machine history is difficult to establish)

A portable appliance tester, therefore giving absolute readings only, ie; pass or fail, would be satisfactory for such tests. Examples of such instruments are the Seaward PAC 500 or the Metrohm PAT

If access is restricted when manually checking the earth path of a particular type of ride, and manual inspections are not possible, a more elaborate instrument giving full analogue or digital readings may be desirable

The reason for this would be to establish a history for the machine which could indicate any deterioration or degradation of the machines integrity from one inspection to another. Examples of test equipment which would perform this function are the Seaward PAT 100s, PAT 100X, MEGGER PAT 2, MEGGER PAT 3, MEGGER PAT 101 or METROHM PAT with digital read out

7. Check low voltage to coin mechanism and other devices, eg; control levers, etc.
8. Where rides are sited outdoors or in adverse situations, it is essential that an RCCB is fitted. Where such a device is fitted, a check should be carried out for suitability and safe operation of such device.

TEST

9. Finally, test the ride by the insertion of a coin and by applying a loading to the ride slightly in excess of the minimum load of 51Kg. (which is the minimum load for a child as laid down by the Fairgrounds and Amusement Parks - A Code of Safe Practice

NOTE 3

On most modern rides, low voltage (derived from a dual wound isolated transformer) is used on all components, eg: coin slot, control levers, lights etc. In such cases bonding to earth of the metal parts associated with these components and other isolated metal parts, may not be necessary, or indeed desirable. If in doubt, Manufacturers advice should be sought.

This test list can only afford general guide lines. The examiner must use discretion and always be aware that the ride safety is the paramount objective. If all checks are found correct, fill out and sign the appropriate form. If any defects are found disconnect the ride and inform the operator or person responsible. Disconnection of the ride should include removal of the fuses or some other means of immobilising the ride prior to informing the operator or person responsible.

Such tests should be carried out at least every fourteen months but it must be realised that the safety of the ride is essential at all times and failure to keep the ride in good condition, in accordance with the above guide lines and the

Fairground and Amusement Parks - A Code of Safe Practice, could render the operator liable to prosecution under the "Health and Safety at Work Act 1974". (Applies to UK customers)

All the above inspections should be carried out by a competent person. All electrical work should be carried out by a qualified electrician

Amutec Kiddie Rides recommend that a ride maintenance sheet is kept as a record of all maintenance and servicing work carried out on the machine

CARE OF FIBREGLASS

Amutec's kiddie ride toys (not the characters) are manufactured in self coloured GRP. This material can be maintained to a high standard using the following simple instructions

1. Day to day cleaning

Wipe down with hot soapy water and polish with a silicone based polish. Ensure the power supply is disconnected during this process and that water does not come into contact with any electrical items

2. Scratches

Scratches can be removed using a cutting type of polish. Amutec recommend Farecla P315 and P615 cutting compounds for this process. (This material should be used in conjunction with the manufacturers instructions). This material is available through Amutec or any good automotive supplier

3. Full Refurbishment

Deep scratches can be removed by using a wet/dry finishing paper. In most cases a 1000 grit should be used. Very deep scratches can be removed with 600 grit paper. In both cases use with plenty of water. After rubbing and drying, the fibreglass will look very dull. The gloss surface can be recovered by polishing using Farecla P315 and P615 with water and preferably a high speed buffing wheel (approximately 1800rpm). Amutec recommend Farecla G mops for high speed buffing

Holes in Fibreglass

Small holes in fibreglass caused by vandalism etc. can be filled using car body filler available from any good automotive outlet. This should be rubbed down to a smooth finish using 600 then 1000 grit wet/dry finishing paper. When completed, these holes can be painted with touch up paint (see paint pantone reference sheet). If any fibreglass damage causes a weakening of the fibreglass structure, manufacturers advice should be sought prior to carrying out any repair work

Touch up paints are available from the manufacturer

CARE OF MECHANICAL PARTS

The mechanism used on all Amutec rides is designed for low maintenance. Whenever the ride is stripped for refurbishment check the following:-

1. condition of 'V' belt
2. tightness of pulleys
3. lubrication in bearings
4. tightness of nuts and bolts

CARE OF ELECTRICAL PARTS

Check condition of earth point

Check the cable for signs of wear every time the machine is emptied (maximum of 1 month)

Check the fuse rating is correct and the mains plug is in good condition every time the machine is emptied (maximum of 1 month)

Check the condition of the earth bond and earth leakage using a calibrated portable appliance tester every six months

Carry out full electrical inspection every year

FAULT FINDING (Stamar 'Tiny Tunes')

To be carried out by a competent person. Ensure volume control is turned up for testing purposes.

<u>Symptom</u>	<u>Check</u>
Coins do not accept - Electronic Validator	Press coin test button on timer. If counter moves and audio prompt is heard, check mech. and ribbon cable connections and for damage to unit.
Coins accept but do not turn counter - Validator	Press coin test button on timer. If audio prompt or flashing start button operates replace counter.
S1 mech. Coin accepted but does not start ride	Check operation and setting of microswitch. Press test button on timer. If ride operates check connections to coin mech.
Ride starts without pressing start button - Electronic mechs.	Check that N/C terminals and common are used on microswitch. Check continuity to timer.
No lights	Check mains supply to PSU in base. Check for 12v LED on timer. If not lit check on-board fuse in PSU. Check for 12v DC at timer input. Check 4 way plug is secure.
Ride sound is heard but no movement	Check motor connections to PSU. Check relay feed from timer to PSU.
Ride operates permanently	Check relay in PSU.

SPARE PART ORDERING

When ordering spare parts please have available the following information:-

1. The serial number of the machine
2. The part number required and a description
3. For some parts the supply voltage and coin settings

TECHNICAL SPECIFICATION

Dimensions

Length	:	130cm	51in
Width	:	130cm	51in
Height	:	164cm	64in
Weight	:	139 kg.	306lbs.

MOTOR:- 180W CONTINUOUSLY RATED DUAL VOLTAGE. THERMAL TRIP FITTED

GEARBOX:- 63:1 REDUCTION MINIMUM BACKLASH GEARS

LIGHTING:- 12v DC FUSE RATING:- (110v MODELS) 6.3amps (fuse is fitted in power supply unit)

Stamar "Tiny Tunes" Configuration Instructions

The new "Tiny Tunes" programmable control unit has three externally accessible DIL switches SW1, SW2 and SW3, which are used to select different modes of operation.

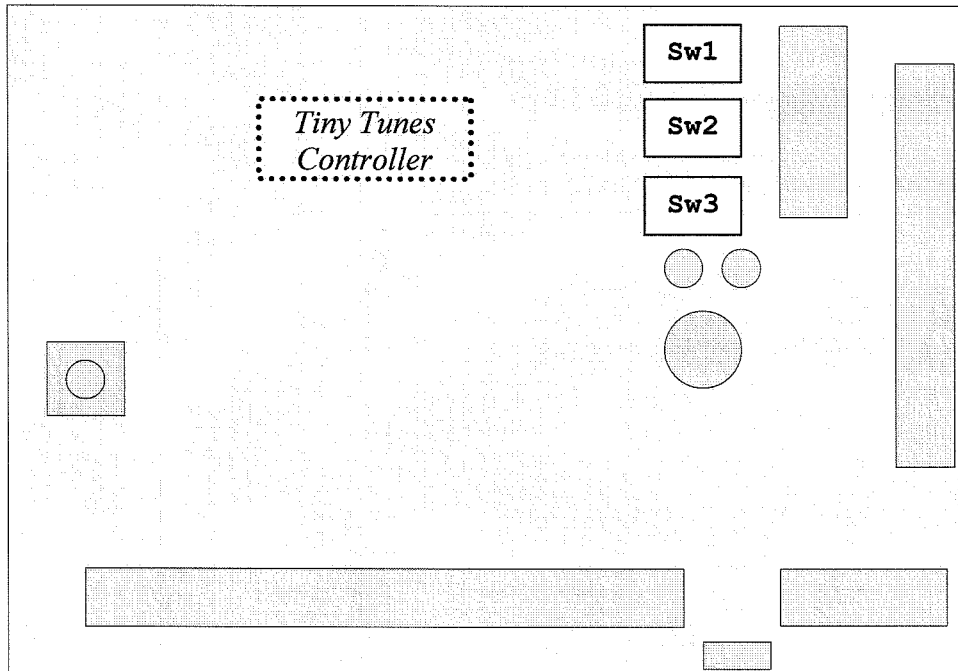

It is advisable to remove the control unit from the ride as this will assist viewing the switches and referring to these instructions. The control unit should only be removed from the ride *after power to the ride has been switched off*.

All alterations to these switches should only be made after power to the ride has been turned off as this will avoid any unintentional damage to the control unit and/or the ride.

SW1 sets either the Price of Play value or Credit Program Options.

Please note that the settings for *either* "price of play" or "credits" on SW1 as shown below are selected using SW2/S1 as shown in SW2 settings below.

- i.e. SW2/S1 must be set to On if "Price of Play" options are required.
 SW2/S1 must be set to Off if "Credit programs" are required.

SW1

S1	S2	S3	S4	Price Of Play Selected	<u>Or</u>	Pre-Programmed Credit Options Available
on	off	off	off	1 Coin	<u>Or</u>	30 P 1 RIDE
off	on	off	off	2 Coin	<u>Or</u>	50 P 2
on	on	off	off	3 Coin	<u>Or</u>	£1 5
off	off	on	off	4 Coin	<u>Or</u>	20 P 1 RIDE
on	off	on	off	5 Coin	<u>Or</u>	50P 1 RIDE
off	on	on	off	6 Coin	<u>Or</u>	£1 3 RIDES
on	on	on	off	7 Coin	<u>Or</u>	£1 2 RIDES
off	off	off	on	8 Coin	<u>Or</u>	10P 1 RIDE
on	off	off	on	9 Coin	<u>Or</u>	30P 4
off	on	off	on	10 Coin	<u>Or</u>	£1 3 RIDES
on	on	off	on	11 Coin	<u>Or</u>	
off	off	on	on	12 Coin	<u>Or</u>	
on	off	on	on	13 Coin	<u>Or</u>	
off	on	on	on	14 Coin	<u>Or</u>	
on	on	on	on	15 Coin	<u>Or</u>	Programmable By User

Please note that the Price Of Play refers to multiples of the Base Coinage that the coin mech. has been programmed to accept.

- Eg. UK mech. programmed for 10P base gives play values from 10p (min) to £1.50 (max)
 USA mech. programmed for 25c base gives play values from 25c (min) to \$3.75 (max)

SW2 is used to set the ride time and either Price of Play or Credit Program Options.

SW2

The ride time can be set from 30 secs to 120 secs in 15 sec increments or to run for as long as the main soundtrack.

Ride Time	S1	S2	S3	S4
30 secs	X	off	off	off
45 secs	X	on	off	off
60 secs	X	off	on	off
75 secs	X	on	on	off
90 secs	X	off	off	on
105 secs	X	on	off	on
120 secs	X	off	on	on
Ride Time Set By Soundtrack	X	on	on	on

Please note that it is not recommended that the "Ride time set by soundtrack" option is used if the ride is fitted with sound effect push switches as the ride will continue to run whilst these switches are continually operated!

SW2

Sw2/1 also selects either price of play or credit program options:

	S1	S2	S3	S4
Select Price of Play options	On	x	x	x
Select Credit Program options	Off	x	x	x

SW3 selects additional ride features

SW3

S1	S2	S3	S4
----	----	----	----

Prompt phrases On/Off	On/Off	x	x	x
Attract sounds On/Off	x	On/Off	x	x
Count No. of Rides	x	x	On	x
Count No. of Coins (coin mech. base coin value)	x	x	Off	x

S4 is used to select "Program Mode" and under normal operating conditions is not used and *Must be set to the OFF position!*

"Program Mode" should only be used by experienced operators familiar with the extended programming sequence, or under direct instruction from either "Amutec" kiddie rides technical dept. or "Stamar Electronics".

Programming instructions are available by request only.

HOW TO ADJUST THE STANDARD OPERATION OF THE RIDE

Volume Control (All Models)

The volume control knob is fitted to the timer which is situated behind the cashbox. Opening this door gives access to live parts. Remove power supply, open door, adjust volume, close door and check that volume is acceptable

COIN MECHANISM

Refer to figs. 1,2, and 3

This section is intended to help the user get the most from the S1 acceptor mechanism. It discusses the adjustments and maintenance of the acceptor and related components. No applications section can be complete, however, and customers are always very welcome to contact us direct.

The frontplate (1/1) is the first check. This prevents entry of oversize, bent or badly distorted coins. The coin passes onto the run-down track formed by the magnet side (1/6) and the swinging side (1/7) which are held together by the bulldog clip (1/8). This track is inclined 14° from the horizontal to permit the coins to run down due to gravity, and 5° from the vertical, so as to check for diameter. As the coin enters the track it passes the washer catcher (1/11). This has a tooth which engages in the hole in a washer preventing further travel of the washer. At this point, the coin passes an over diameter stop on the adjustable slider (1/9), which stops the passage of slightly oversize coins.

If the coin is not over diameter, it passes further to an under diameter check. Here the coin is tilted an extra 4° from vertical against the under diameter ridge on the slider. Under diameter coins fall past this ridge to be rejected.

The base of the track has an under thickness gate, where thinner coins fall through to reject. The coin deflecting cones stop over thickness coins in the track by forcing the coins against the under diameter ridge in the slider. These coins are returned by pressing the reject button (1/4) which splits the track. When the reject button is released, it is returned to its original position by the button spring (1/2), allowing the acceptor to close up again. Rejected coins then either exit through a chute at the bottom of the acceptor (indirect reject) or are guided via the return chute (1/5) through the reject slot in the frontplate, and come to rest in the u-bolt (1/3).

The magnet positioned in the 'magnet-side' (1/6) of the rundown stops all ferromagnetic blanks. These can be stripped clear by the swinging side (1/7), by pressing the reject button (1/4). The anti-tilt leg (1/10) prevents cheating the acceptor by tilting the machine to gain acceptance of under diameter coins. If the machine is tilted, the leg swings across the track and prevents entry of all coins.

The final test is in the black marinyl cradle (1/13 to 1/20). This incorporates a diameter check in the form of a cradle (1/17) and weight (1/18). Under diameter coins fall straight through the cradle and fail to actuate the microswitch (1/19). The true coin then passes through an interlock mechanism (1/15) prior to actuating the microswitch. This interlock prevents 'coin-on-cotton' cheating and fishing. The coin guide (1/16) is adjusted to ensure that the coin hits the microswitch arm in the correct position.

If the optional lock out assembly (1/21 to 1/25) is fitted, the lockout arm (1/24) will prevent entry of coins into the mechanism. To enable coin acceptance, the correct voltage must be applied to the lock out coil (1/22) which will then withdraw the lock out arm from the coin path.

ADJUSTMENT

The S1 mechanism can be adjusted both for diameter and thickness. The thickness adjustment is done first as this effects the diameter setting. It is often impossible to do this adjustment whilst the mechanism is still within the machine. It is therefore advisable that a spare fixed side be carried by a service engineer, so that the swinging side can be removed from the machine (by removing the bull-dog clip), and temporarily attached to the spare. This will allow the swinging side to be adjusted outside the machine.

COIN MECHANISM

Refer to Figs. 1, 2 and 3

THICKNESS

To adjust the thickness setting, first release the setting screw locknuts. Place a true coin on a track and adjust the thickness setting to a point where the coin just starts to fall through the coin track at both ends of the track. Before tightening the locknuts, the screws should be withdrawn just sufficient to allow the good coin to ride on the edge of the track at the fixed side.

DIAMETER

The diameter setting is adjusted by moving the slider. Release the slider fixing screws, and with a true coin, adjust the slider so that it is parallel to the base of the coin track, and just stops the coin from falling out of the side of the run down. Check this at both ends of the track, and if correct, re-tighten the fixing screws. Check both settings using new and well-worn coins of the correct denomination, and check for rejection of incorrect coins and any problem blanks.

MICROSWITCH

The microswitch accept chute is adjustable to one of four widths. This is factory adjusted to the correct diameter and should not require field adjustment.

The microswitch actuating wire should not catch on the side of the black plastic microswitch bracket. At its resting position, the wire should run along the mid point of a small ridge in the bracket.

The microswitch is available in three different spring tensions - identified by the colour of the plastic boss at the wires pivot point.

Red: Light tension e.g. 1 Aus. Sch. 25c NL.

Black: Medium tension e.g. 2p and other intermediate coins.

White: Heavy tension e.g. 10p, 10p 5DM.

For security reasons, the microswitch with the heaviest tension which still allows the coin to pass is fitted.

Finally, check that the interlock hangs freely as this prevents the coin-on-cotton fiddle.

IF THE ABOVE PROCEDURES ARE NOT SUCCESSFUL, CHECK FOR WORN OR DAMAGED PARTS AND REPLACE WHERE NECESSARY.

LOCK OUT COILS

Voltage	Current	Power	Colour Code
240V AC	30.0 mA	7.2 VA	White + Blue
110V AC	42.0 mA	4.62 VA	White + Green
50V AC	76.5 mA	3.8 VA	White + Red
24V AC	240.0 mA	5.76 VA	White + Yellow
12V AC	240.0 mA	2.88 VA	White + Grey
24V DC	300.0 mA	7.2 W	Black + Yellow Band
12V DC	350.0 mA	4.2 W	Black + Grey/Blue Band
10V DC	300.0 mA	3.2 W	Black + Brown

Fig. 1 S1 Acceptor

S1 Acceptor

A single coin mechanical 'Roll Down' acceptor, it is jam resistant and comes complete with accept - reject assembly. It is economical in size/shape, simple in construction and easy to adjust. It incorporates the Marinyl switch/cradle assembly (fitted as standard) and is also available with meter microswitch bracket or flip flap assembly.

Features

- Track adjustable or preset for all coins from 17mm-30mm
- Coin on cotton catch
- Washer catcher
- Diameter, thickness and ferrous content check
- Tests for underweight coins/fraud
- S/S front plate with up to 4 entries
- Reject button and reject outlet
- Lockout coil wound for most AC and DC voltages
- Busy B bounce resistant coin microswitch
- Indirect entry available
- Indirect reject available
- Anti-strimmer wire available for use with marinyl cradle

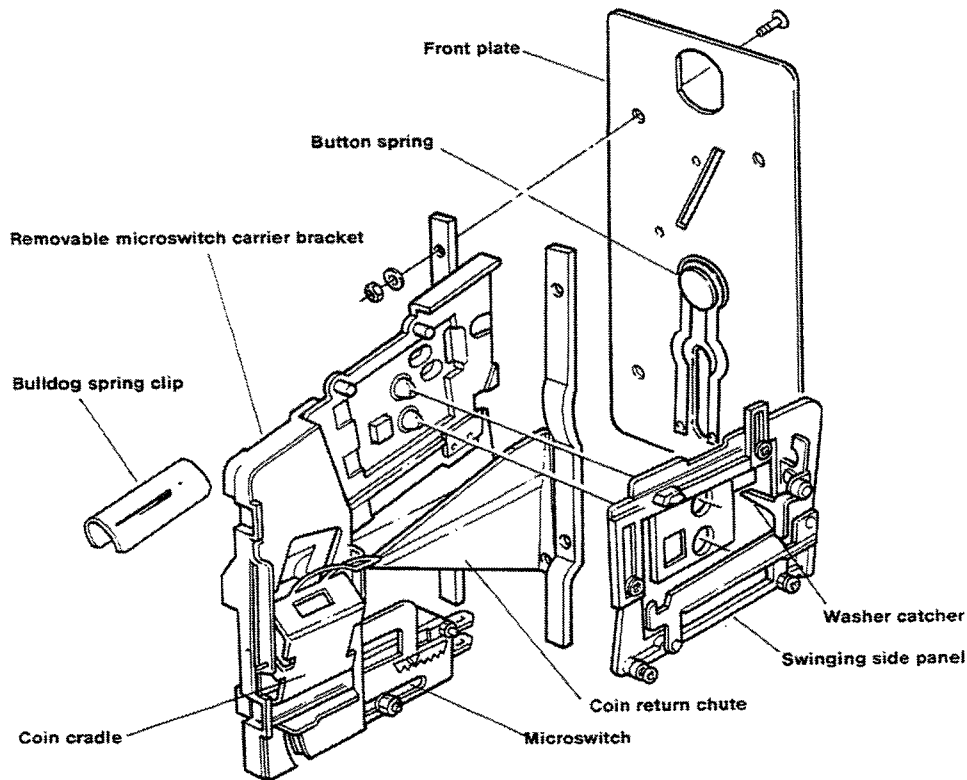
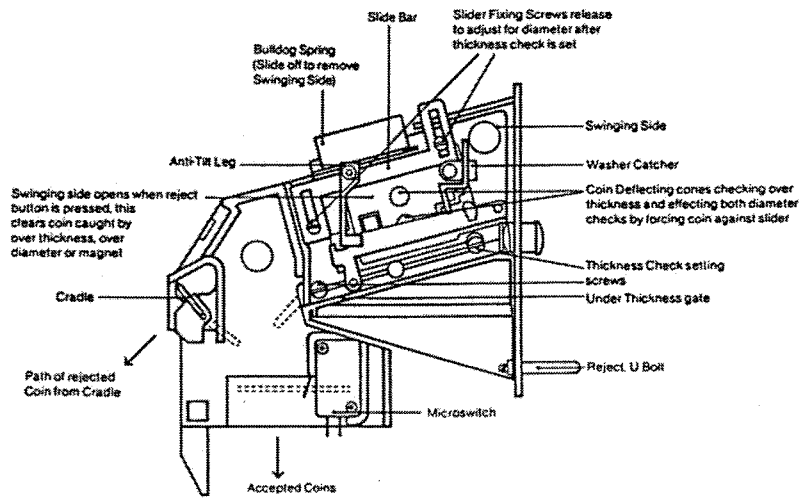

Fig. 2 Dimensional Checks

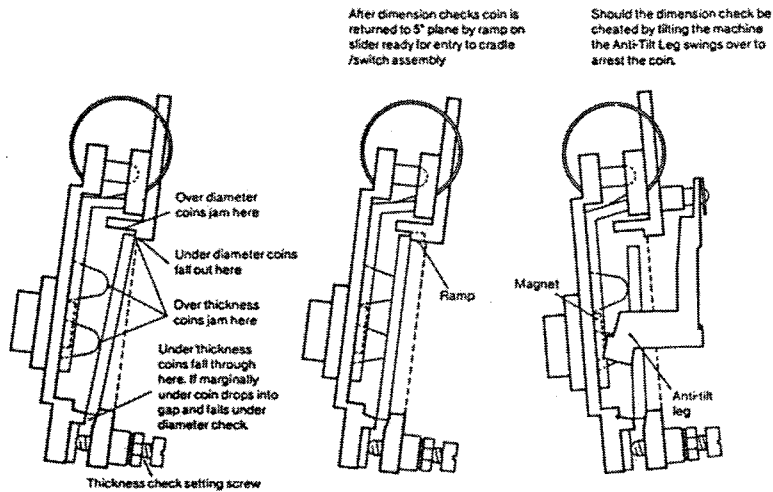
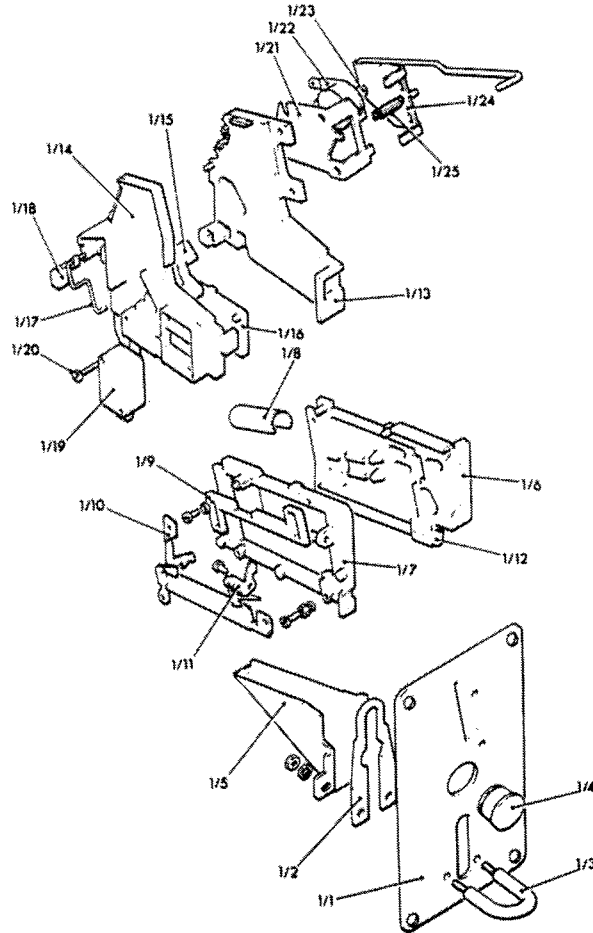

Fig. 3 Exploded Diagram

Parts List

- 1/1 Front plate
(state coinage)
- 1/2 Button Spring
- 1/3 U Bolt
- 1/4 Button
- 1/5 Return Chute
- 1/6 Magnet Side
(state coinage)
- 1/7 Swinging Side
- 1/8 Bulldog Spring
- 1/9 Slider
- 1/10 Anti-tilt leg
- 1/11 Washer catcher
- 1/12 Button Stop
- 1/13 Fixed Side
(M/Sw Brkt)
- 1/14 Removable Side
(M/Sw Brkt)
- 1/15 Interlock
- 1/16 Coin guide
- 1/17 Cradle (state coinage)
- 1/18 Cradle weight (state coinage)
- 1/19 Microswitch (state coinage)
- 1/20 M/Sw Screws (2)
- 1/21 Lockout bracket
- 1/22 Lockout coil (state voltage)
- 1/23 Pole piece
- 1/24 Lockout arm (state type)
- 1/25 Lockout spring



AMUTEC SYSTEM 4000 TINY TUNES CONTROLLER

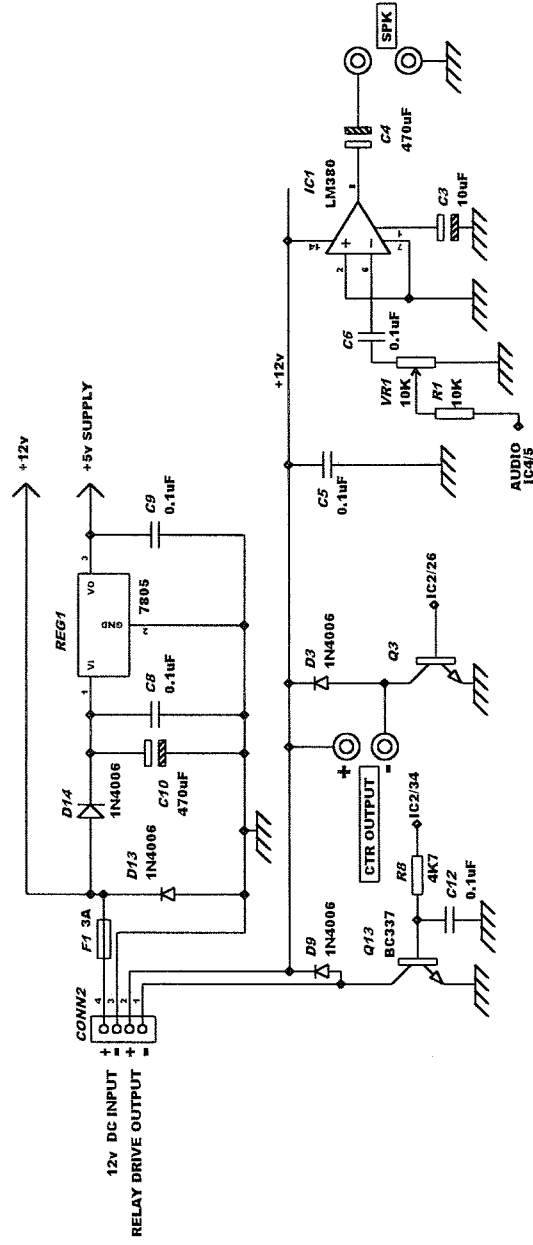

STAMAR ELECTRONICS
 NORTH CLIFTON
 NEWARK

DRG. No. AMUJ82 ISSUE 3

AMUTEC SYSTEM 4000 TINY TUNES CONTROLLER

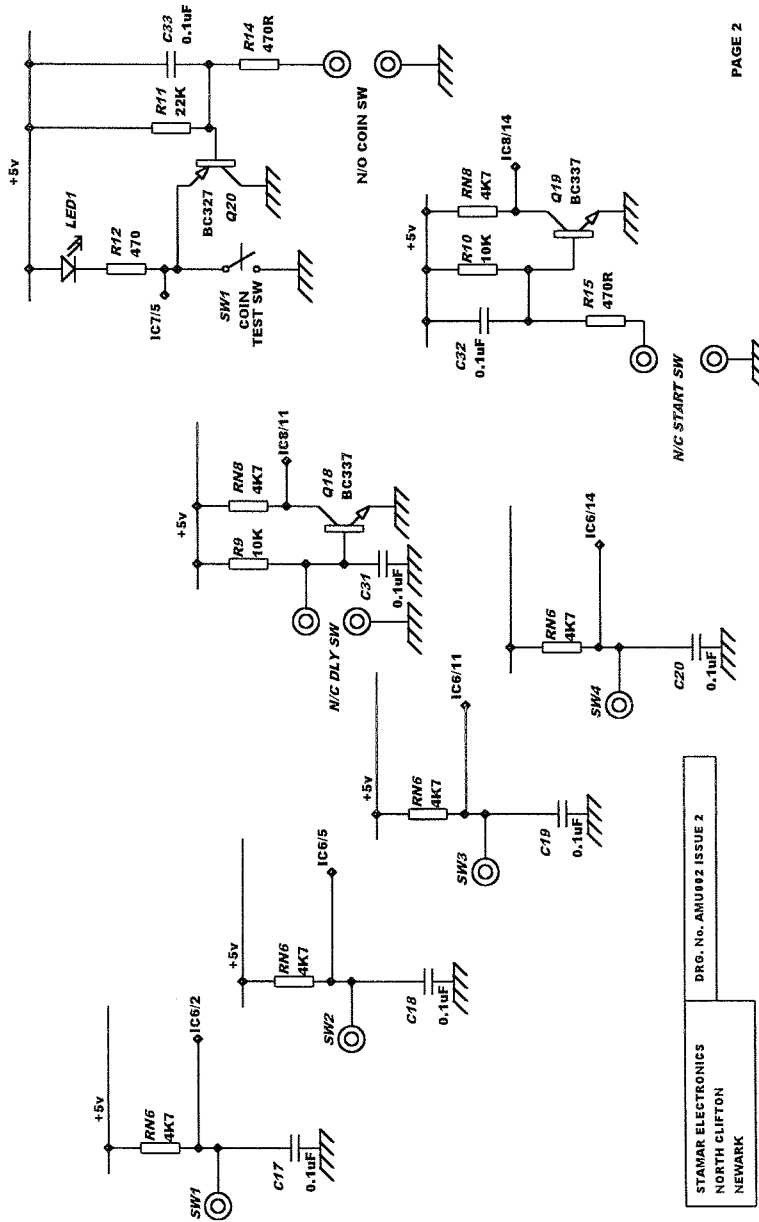

STAMAR ELECTRONICS
 NORTH CLIFTON
 NEWARK

N/C START SW

AMUTEC SYSTEM 4000 TINY TUNES CONTROLLER

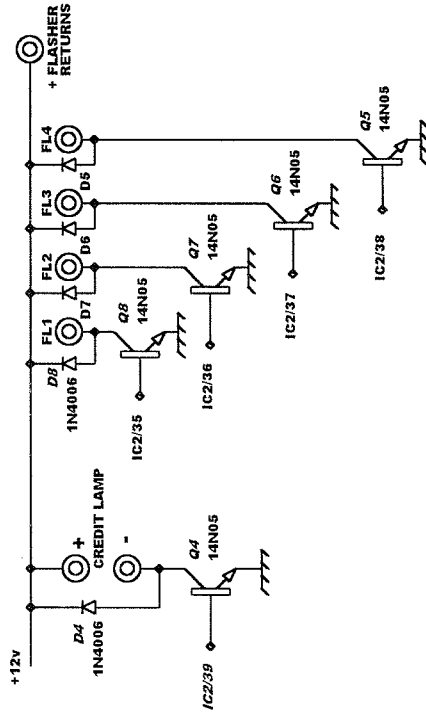

STAMAR ELECTRONICS
NORTH CLIFTON
NEWARK

DRG. No. AMU802 ISSUE 3

AMUTEC SYSTEM 4000 TINY TUNES CONTROLLER

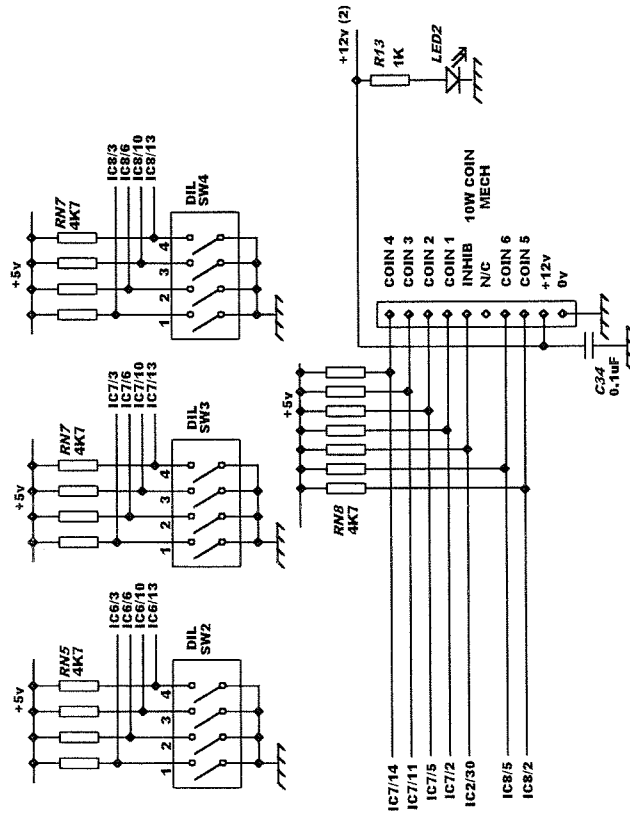

STAMAR ELECTRONICS
 NORTH CLIFTON
 NEWARK

DRG. No., ARU802 ISSUE 2

AMUTEC SYSTEM 4000 TINY TUNES CONTROLLER

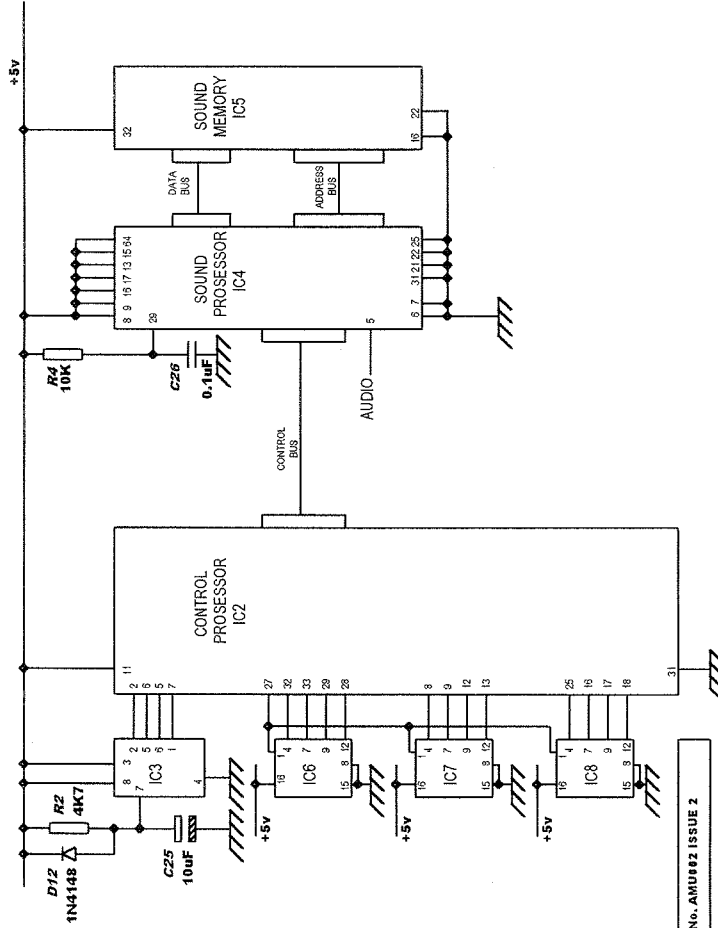

STAMAR ELECTRONICS
 NORTH CLIFTON
 NEWARK

DRG. No. AMU002 ISSUE 2

STAMAR 12V 30VA DC PSU1 UNIT

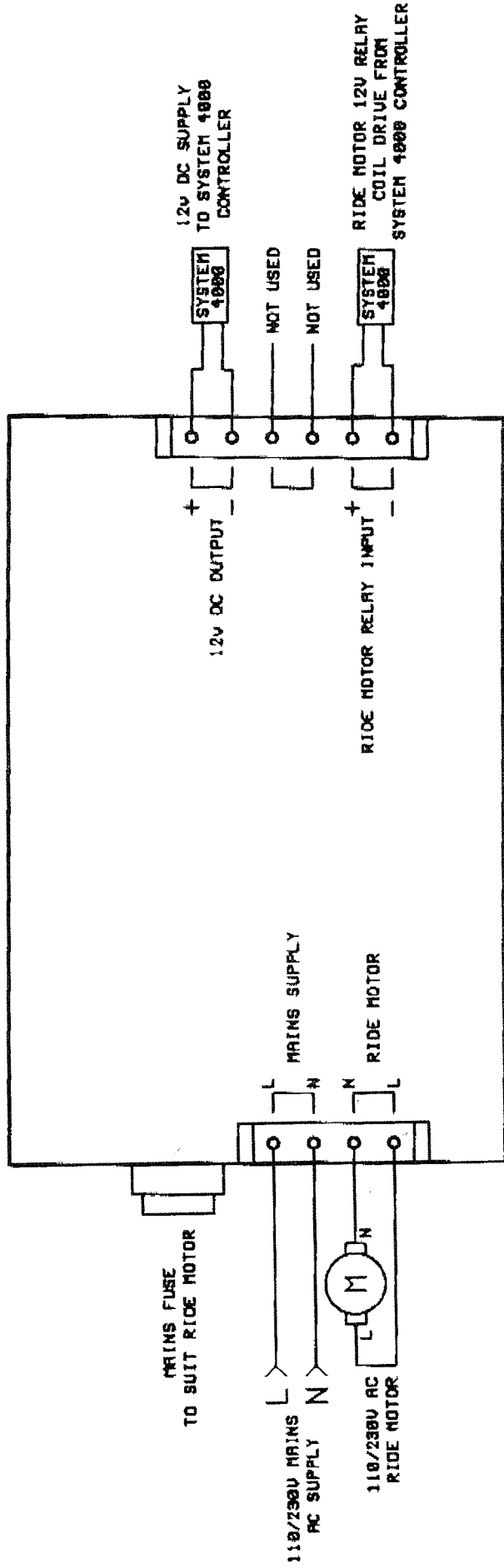

CUSTOMER: GENERAL
REVISION No: SA 28/07/00 DRG. No. PSU1-01
STAMAR ELECTRONICS MORTH CLIFTON TEL: 01777 228666

Title

NOO NOO - S1 Mech

Customer

Amutec Ltd

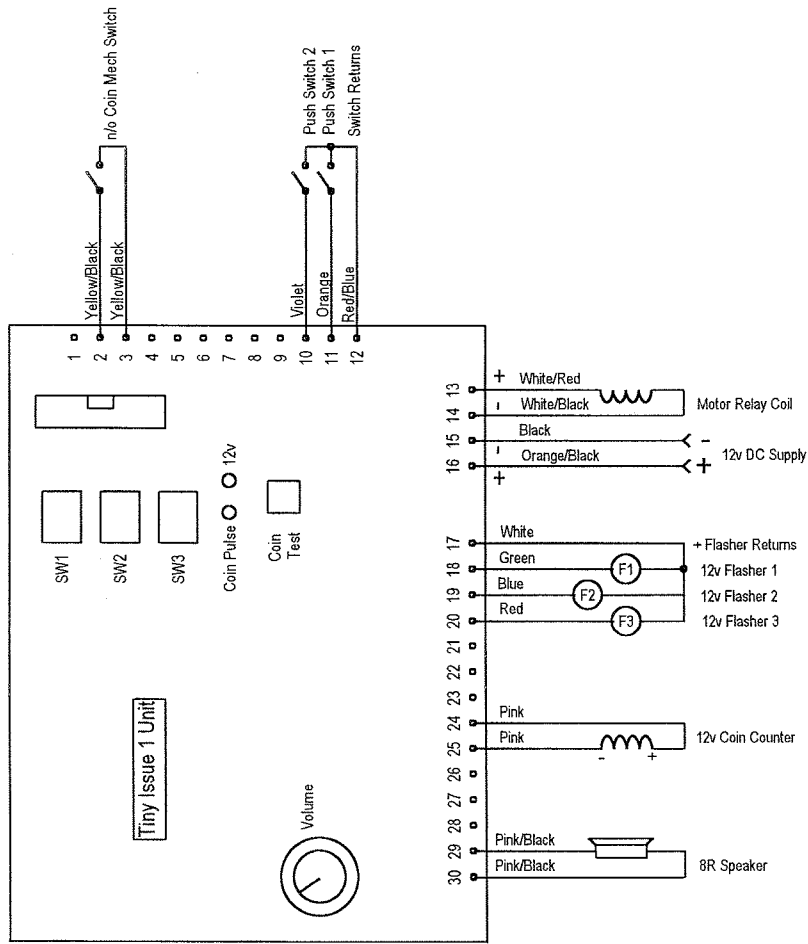

Stamar Electronics
 North Clifton
 Newark
 NG23 7AU
 01777 228665

DRG. No. S00006



Date

26th July 2000

Revision 3



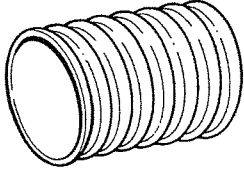
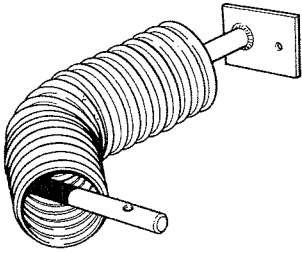
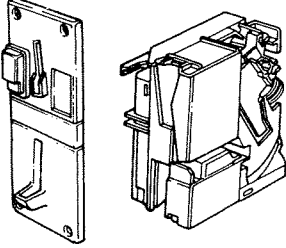

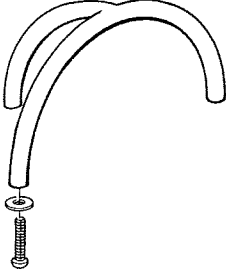
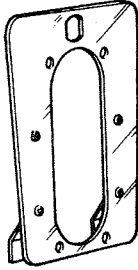
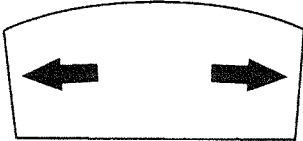
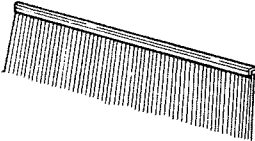
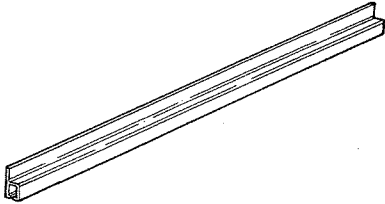
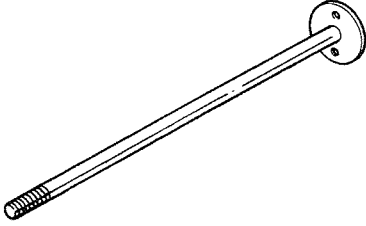
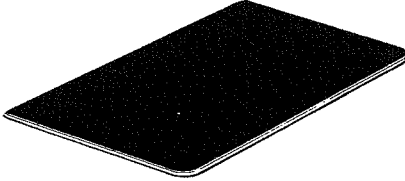
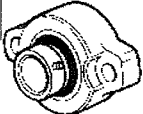
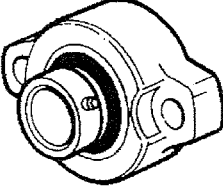
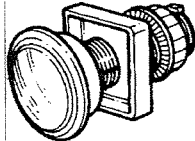
Revision 2

Revision 1

<p>AMT 0944</p>  <p>HOSE EYE (FOR EYE ONLY)</p>	<p>AMT 1132</p>  <p>HOSE ASSEMBLY</p>	<p>AMT 0613 - FRONT PLATE AMT 0585 - UK COIN MECH AMT 0586 - OTHER COIN MECH</p> 
<p>AMT 0952</p>  <p>DOMES</p>	<p>AMT 0953</p>  <p>DOMES GUARD</p>	<p>AMT 0591</p>  <p>COIN MECH PLATE</p>
<p>AMT 1070</p>  <p>DIRECTION PLAQUE</p>	<p>AMT 0945</p>  <p>STRIP BRUSH</p>	<p>AMT 1089</p>  <p>STRIP BRUSH CARRIER</p>
<p>AMT 1092</p>  <p>EYE BAR</p>	<p>AMT 0946</p>  <p>ANTI-SLIP FLOOR PAN</p>	<p>AMT 0955</p> <div data-bbox="1123 1473 1362 1576" style="border: 1px solid black; padding: 5px; text-align: center;"> <p>© and ™ Ragdoll 1996 Licensed by BBC Worldwide Limited</p> </div> <p>TRADE MARK STICKER</p>
<p>AMT 1030</p>  <p>BEARING 12mm</p>	<p>AMT 1027</p>  <p>BEARING 20mm</p>	<p>AMT 0727</p>  <p>LOW PROFILE MCPB BUTTON</p>

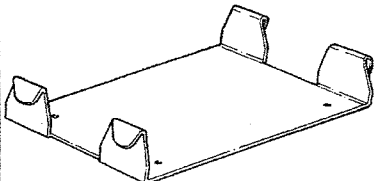
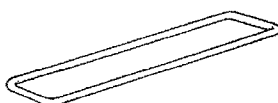
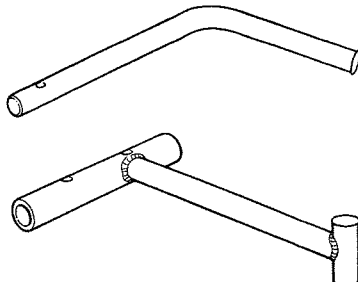
NOO NOO

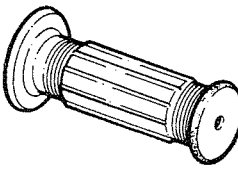
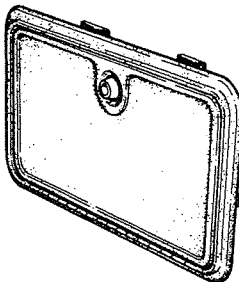
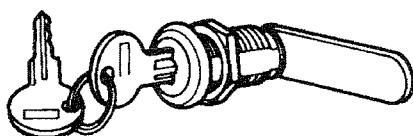
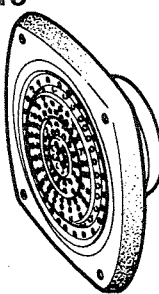
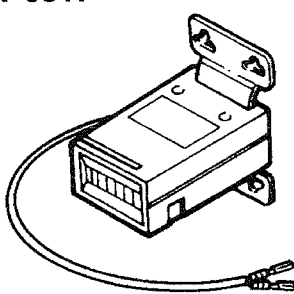
AMUTEC

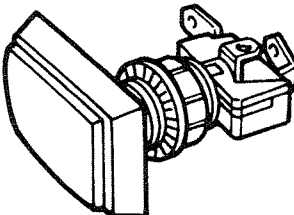
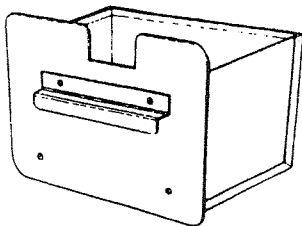
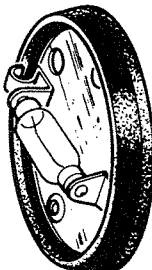
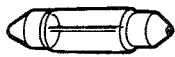
<p>AMT 1061</p>  <p>TIMER CRADLE</p>	<p>AMT 1063</p>  <p>RUBBER BAND</p>	<p>AMT 0951</p>  <p>COLUMN ACTUATOR</p>						
<p>AMT 0071</p>  <p>BEARING 12mm (ROD END)</p>	<p>AMT 0951</p>  <p>HANDGRIP</p>	<p>AMT 0075</p>  <p>CASH BOX DOOR</p>						
<p>AMT 0592</p>  <p>COIN MECH LOCK</p>	<p>AMT 0515</p>  <p>SPEAKER COVER</p>	<p>AMT 0517</p>  <p>12V FOOT MOUNT COUNTER</p>						
<p>AMT 0553</p> <div style="border: 1px solid black; padding: 5px;"> <p> MINIMUM AGE - 3 YEARS MAXIMUM AGE - 8 YEARS</p> <p>CHILDREN MUST BE SUPERVISED BY AN ADULT AND SEATED AT ALL TIMES WHEN RIDING THIS MACHINE</p> <p>DO NOT PERMIT MORE THAN ONE CHILD AT A TIME ON THIS MACHINE</p> </div> <p>MINIMUM AGE PLATE</p>	<p>AMT 0414</p>  <p>START BUTTON</p>	<p>AMT 0062</p>  <p>CASH BOX</p>						
<p>AMT 0932</p> <div style="border: 1px solid black; padding: 5px;"> <table border="1" style="width: 100%; border-collapse: collapse;"> <tr> <td style="text-align: center;">1 RIDE</td> <td style="text-align: center;">30p</td> </tr> <tr> <td style="text-align: center;">2 RIDES</td> <td style="text-align: center;">50p</td> </tr> <tr> <td style="text-align: center;">3 RIDES</td> <td style="text-align: center;">£1</td> </tr> </table> <p style="text-align: center;">CHILD MUST BE SEATED BEFORE INSERTING COIN(s)</p> <p style="text-align: center;">This machine accepts 10p - 20p - 50p & £1 coins NO CHANGE GIVEN</p> </div> <p>INSTRUCTION PLATE</p>	1 RIDE	30p	2 RIDES	50p	3 RIDES	£1	<p>AMT 1133</p> <p>WIPAC BASE UNIT</p>   <p>AMT 0042</p> <p>5w FESTOON BULB</p>	
1 RIDE	30p							
2 RIDES	50p							
3 RIDES	£1							

Item	Description	Part No.
1	GEARBOX	AMT 1243
2	CRANK to A280 GEARBOX	AMT 0078
3	SPACER	AMT 0311
4	SL1" BEARING	AMT 0060
5	ROCKER FRAME	AMT 0956
6	FRAME - top section Noo-noo	AMT 0957
7	SL12mm BEARING	AMT 0061
8	PULLEY 3 1/2" x 10mm	AMT 0081
9	V' BELT A740/A28	AMT 0082
10	PULLEY 2" x 1 1/2"	AMT 0073
11	MOTOR 1/4HP (state voltage)	AMT 0051
12	INSPECTION PANEL Noo-noo	AMT 0958
13	FRAME - Noo-noo Base	AMT 0940
14	CONTROL UNIT - Noo-noo	AMT 0948
15	BUNG 1" Square	AMT 0027

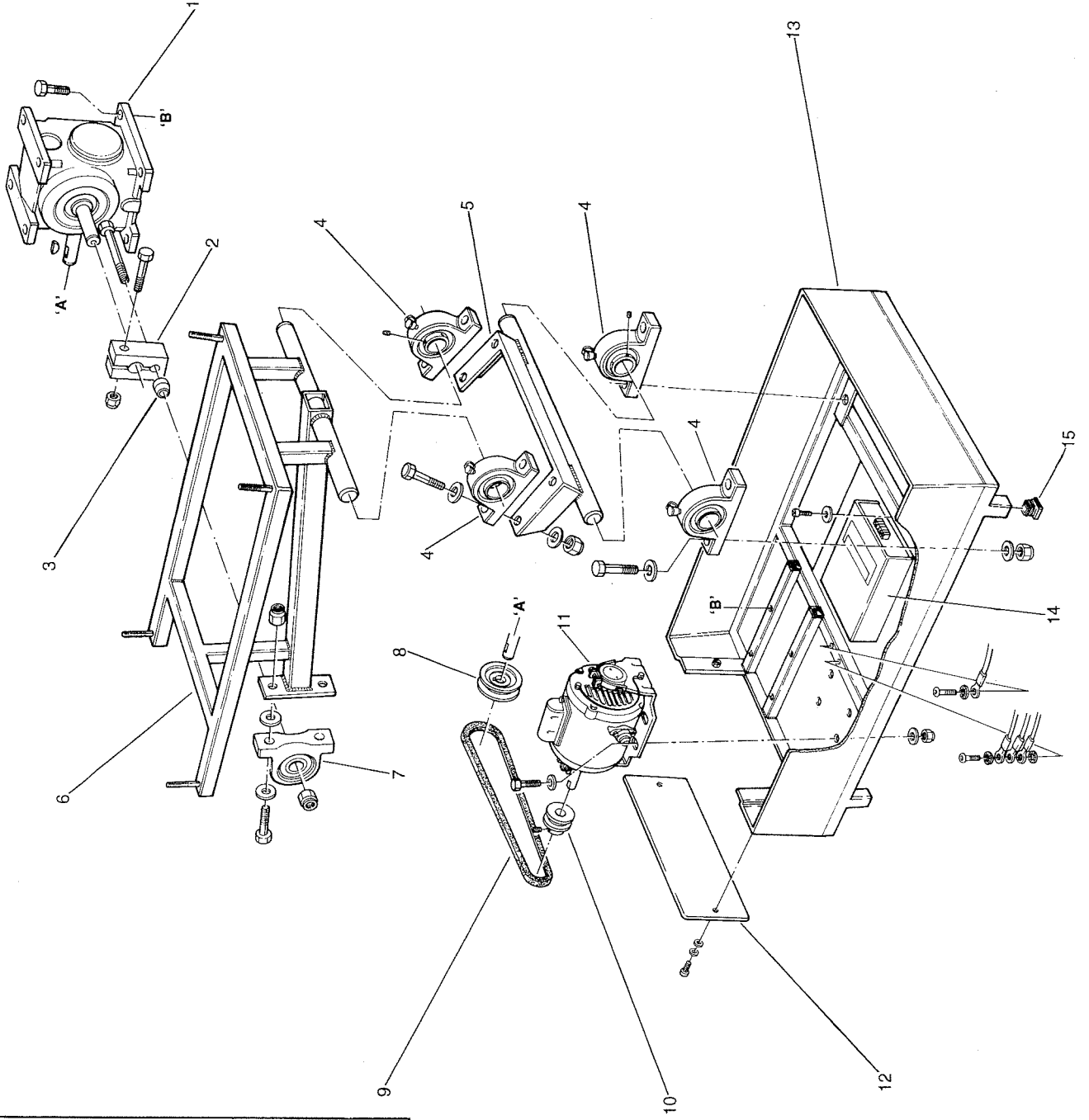

AMUTEC
NOO NOO MECHANISM

