

MONOPOLY



THE CLASSIC
LICENSE
DIMENSIONS:
W 41" x D 60" x H 93"



Re-Spin

I C E G A M E . C O M



Table of Contents

Safety, Warnings, and Power Requirements	4
Operator Controls	5
Program Menus and Options	6
Service	
Major Component Access	14
Marquee Illumination	15
Monitor Removal	16
Monitor Power Supply Removal	18
Power Supply Specifications	19
Warranty	20

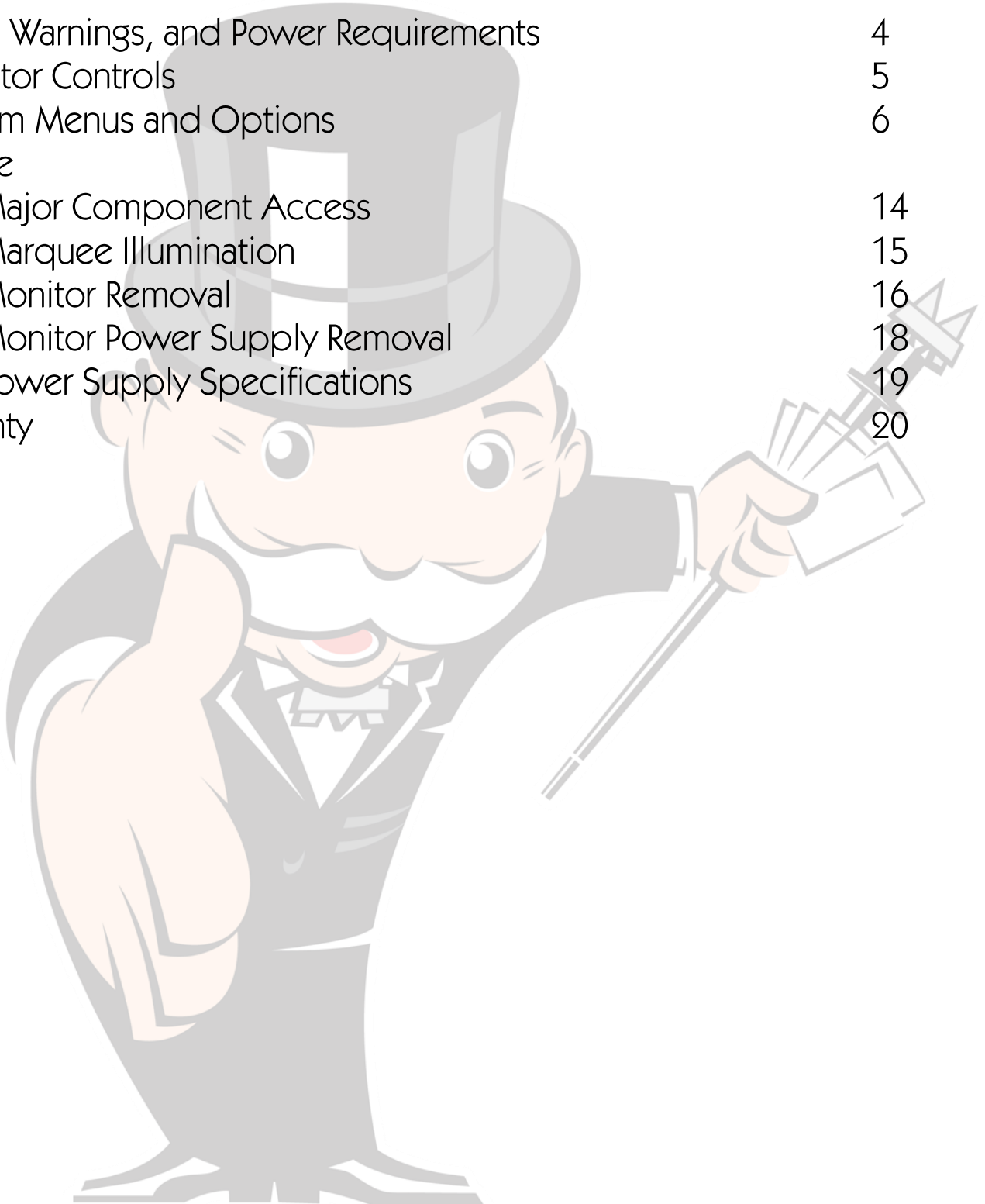



SAFETY AND WARNINGS BEFORE YOU BEGIN

WARNING: WHEN INSTALLING THIS GAME, A GROUNDED A.C. RECEPTACLE MUST BE USED. FAILURE TO DO SO COULD RESULT IN INJURY TO YOURSELF OR OTHERS. FAILURE TO USE A GROUNDED RECEPTACLE COULD ALSO CAUSE IMPROPER GAME OPERATION, OR DAMAGE TO THE ELECTRONICS.

NOTE: THIS GAME IS INTENDED FOR INDOOR USE ONLY.

DO NOT DEFEAT OR REMOVE THE GROUNDING PRONG ON THE POWER CORD FOR THE SAME REASON AS GIVEN ABOVE. USING AN IMPROPERLY GROUNDED GAME COULD VOID YOUR WARRANTY.

HAVE A QUALIFIED ELECTRICIAN CHECK YOUR A.C. RECEPTACLE TO BE SURE THE GROUND IS FUNCTIONING PROPERLY.

THIS GAME IS DESIGNED TO DISSIPATE STATIC ELECTRICITY THROUGH THE GROUNDING PLANE OF THE GAME. IF THE A.C. GROUND DOES NOT WORK, THE GAME COULD DISCHARGE STATIC ELECTRICITY THROUGH THE GAME CIRCUITRY, WHICH COULD CAUSE DAMAGE.

THE POWER SUPPLY IS NOT VOLTAGE ADJUSTABLE. TO OPERATE THE GAME AT VOLTAGES OTHER THAN THOSE IT WAS DESIGNED FOR. PLEASE CONTACT OUR SERVICE DEPARTMENT FOR VOLTAGE CONVERSION INFORMATION.

WARNING

DO NOT remove any of the components on the main board (e.g. compact flash and eproms) while the game is powered on. This may cause permanent damage to the parts and the main board. Removing any main board component part while powered on will void the warranty.

ALWAYS REMOVE POWER TO THE GAME, BEFORE ATTEMPTING ANY SERVICE, UNLESS NEEDED FOR SPECIFIC TESTING. FAILURE TO OBSERVE THIS PRECAUTION COULD RESULT IN SERIOUS INJURY TO YOURSELF OR OTHERS.

THIS GAME IS NOT SUITABLE FOR INSTALLATION IN AN AREA WHERE A WATER JET COULD BE USED.

This appliance is not intended for use by persons (including children) with reduced physical, sensory or mental capabilities, or lack of experience and knowledge, unless they have been given supervision or instruction concerning use of the appliance by a person responsible for their safety. Children should be supervised to ensure that they do not play with the appliance

AC Power Information

The games main fuse is accessed through the back of the game at the power mod. Above the power cord is a small panel that contains the main fuse. The value of the fuse for 120 volt users is 5 AMPS at 250Volt type slow blow. The value of the fuse for 230 users is 2.5 AMPS at 250Volt type slow blow.



USER CONTROL PANEL

The games' user control panel is located behind the upper coin door. The user control panel contains both the coin meter and ticket meter. It also has control buttons that can enter programming to change game options, give a test credit to play the game, and adjust the games' volume without entering programming.

Use the buttons labeled "DOWN" and "UP" to adjust the volume when in game mode.

Use the button labeled "SERVICE" to provide a service credit to play the game.

Use the "TEST" button to enter program mode. In program mode, the buttons labeled "UP" and "DOWN" will move between options. The button labeled "SERVICE" selects the option. When a option is selected the buttons labeled "UP" and "DOWN" will cycle through the different settings available for that option.

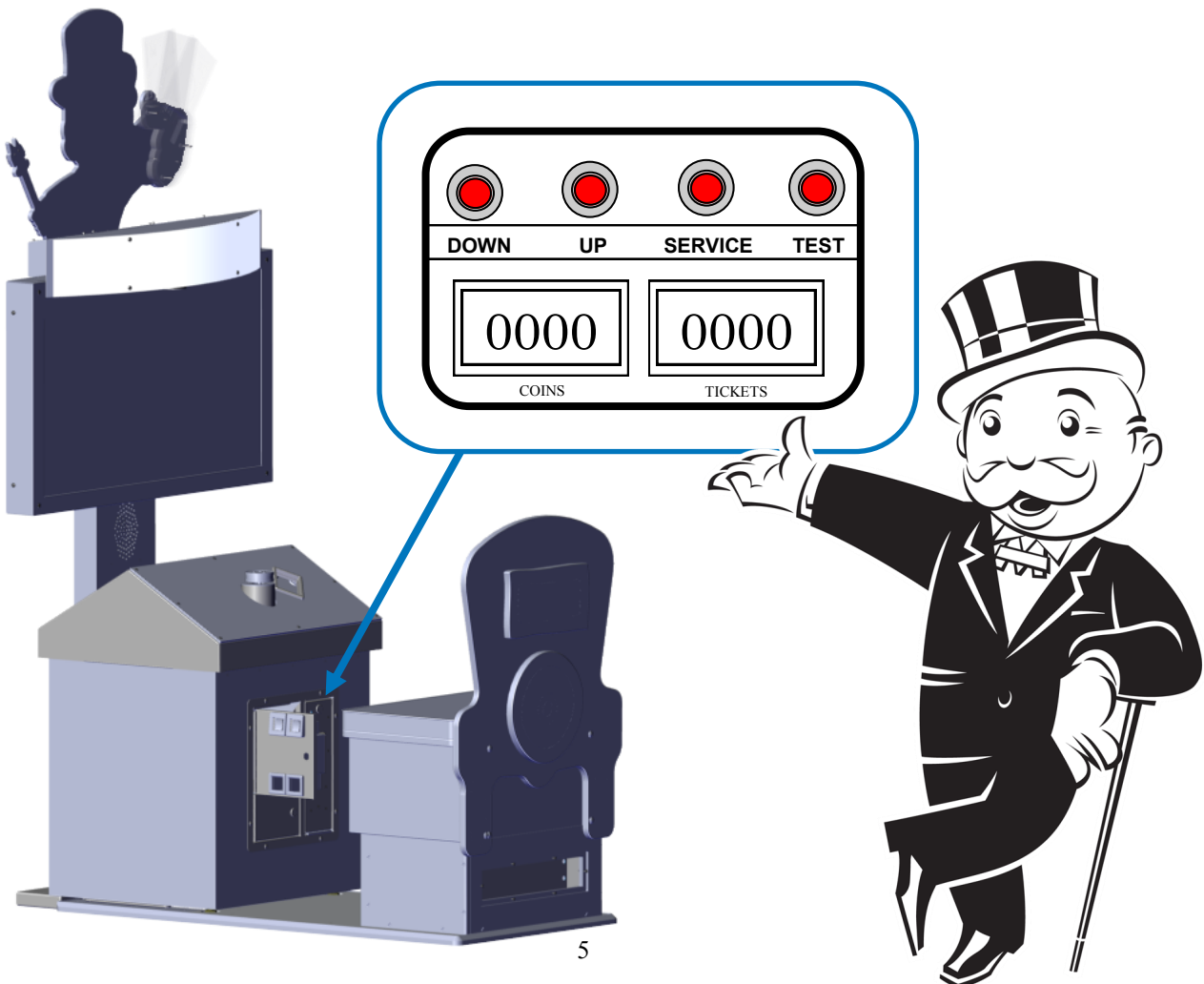



PROGRAM MENUS AND OPTIONS

Monopoly Arcade Main menu

Exit

Selecting this will return to the game's attract mode.

Factory Setup

This menu will pre-configure your game in three different ways.

Adjustments

This menu will allow you to manually change the different options of the game.

Audits

This menu will allow you to view the different saved information from the game.

Resets

This menu will allow you to clear various stored data for the game including credits

System Information

Selecting this menu will give you options to check status of game systems.

Tests

Selecting this test will give you different menus to confirm proper operation of your game.

Utilities

This menu will allow you to calibrate the game's spinner.

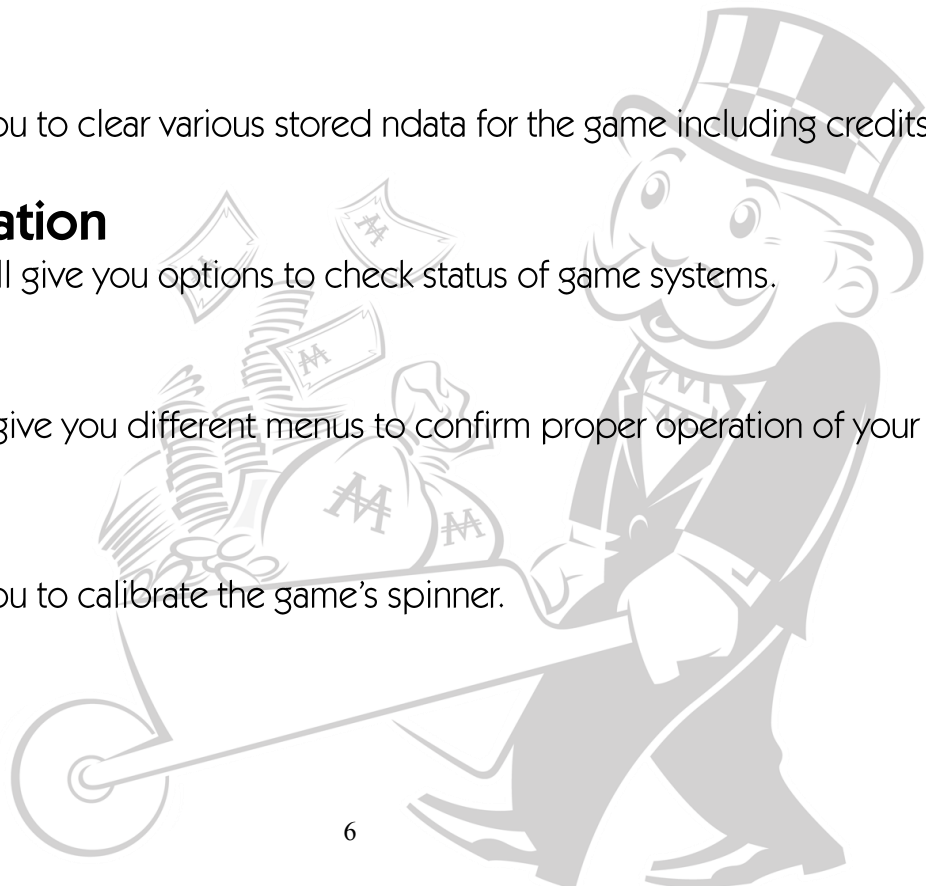
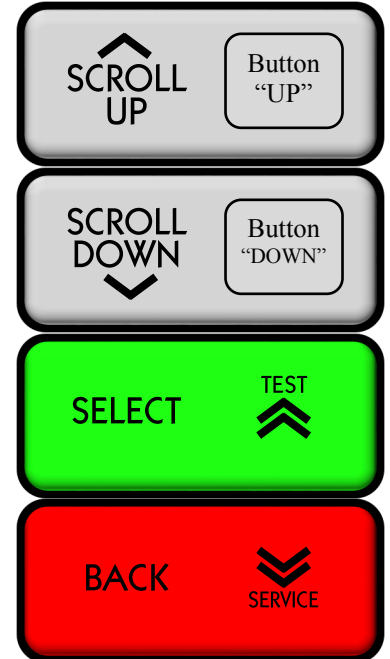



PROGRAM MENUS AND OPTIONS

Monopoly Arcade Factory Settings menu

USA

Selecting this option will preset your game with suggestive settings for use in the United States of America..

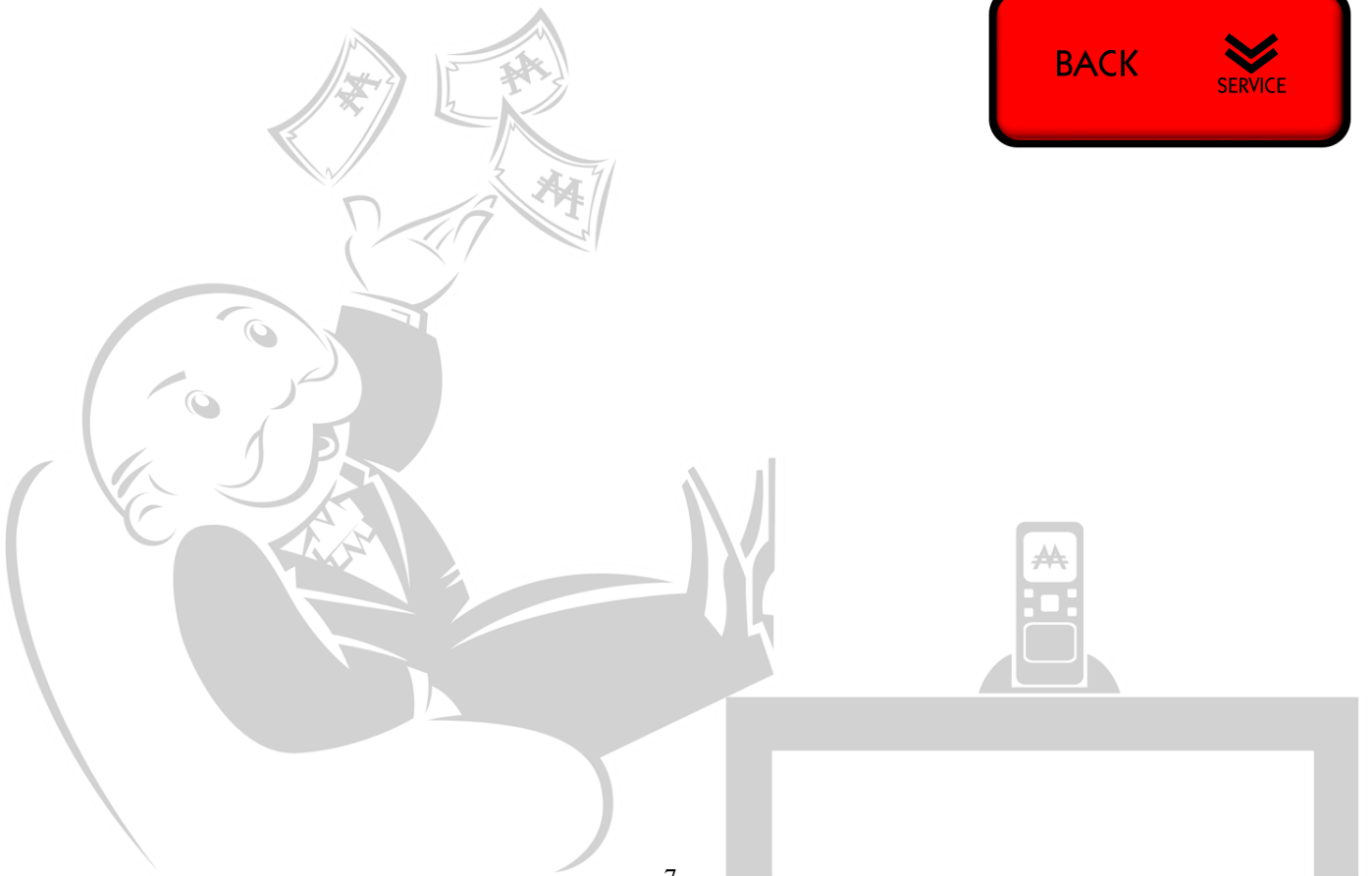
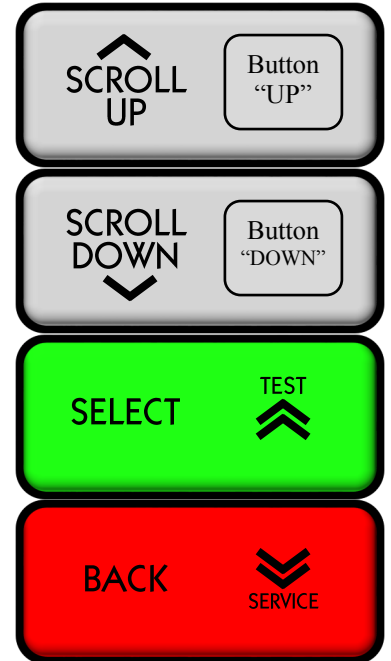



PROGRAM MENUS AND OPTIONS

Monopoly Arcade Adjustments menu

Date / Time Adjustments

This menu will allow you to set the time and date on the games' computer to match your date and time. This is important if you are using the games' generated audit information.

Player Cost Adjustments

Under this menu there are two options. One option enables free play mode which will allow the game to be played for free and the other determines the price to play the game if free play is disabled.

Sound Adjustments

This menu will allow you to set the game and the attract volumes differently. It will also allow you to alter the frequency of when the attract audio is heard.

Gameplay Adjustments

This menu will give you the option of how many rolls of the dice per game and if the player can continue the game if more money is inserted.

Redemption Award Adjustments

This menu allows you to change what is displayed on the screen (Tickets or Coupons). You can set the game to either pay no tickets or coupons (instead it will show points when won), let the game dispense tickets depending on how the player plays, or give away a fixed amount of tickets or coupons. Each of those settings will display different sub menus like payout percentage (what you want to give back to the player in the form of tickets or coupons), what your ticket is worth in money, if you wish to use a ticket multiplier (for 2 point tickets) and how the game will restart dispensing tickets or coupons when they are refilled.

Coin Adjustments

This menu has options to set the currency type (Swipes, US Dollars, Pounds, etc...), the value of your coin or what each swipe is worth, how much your Dollar Bill Validator pulse is valued at, and how much a service credit is valued at.

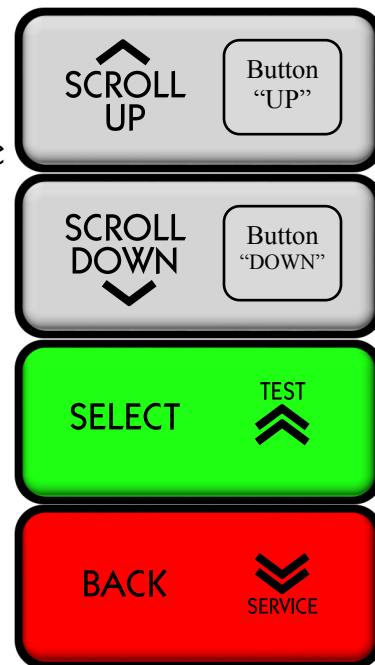



PROGRAM MENUS AND OPTIONS

Monopoly Arcade Audits menu

Coin Audits

This screen shows the total amount of money in, the total amount of coins that was inserted in coin slot 1 and 2, how many pulses it received from the dollar bill validator, and any service credits used.



System Audits

This screen shows how many watchdogs, exceptions, bad traps, maintenance power cycles, and maintenance reboots occurred. This information is useful for ICE Technical support.

Gameplay Audits

This screen provides detail information on how the game was played, length of the game, and the different bonuses won.

Redemption Award Audits

This screen shows your current payout percentage, total amount of tickets awarded





PROGRAM MENUS AND OPTIONS

Monopoly Arcade Resets menu

Reset Credits

This option will clear any remaining credits.

Reset Coin Audits

This option will reset all coin audits.

Reset Adjustments

This option will return the game to preset values that was configured in a previous menu.

Reset Gameplay & Ticket Audits

This option clears gameplay statics and ticket payouts.

Reset Tickets Owed

This option clears any tickets still owed.

Reset Hardware Monitoring Data

This option clears all diagnostic information.

Factory Reset

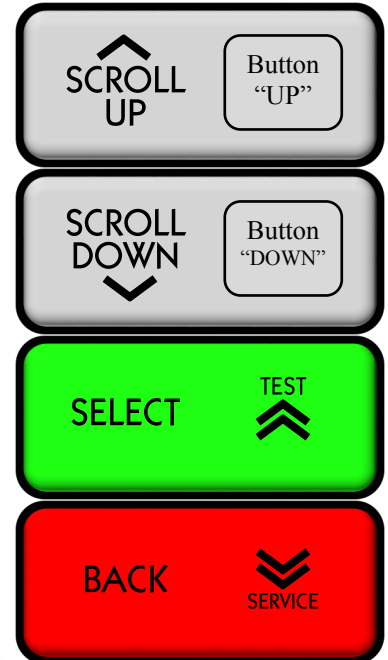



PROGRAM MENUS AND OPTIONS

Monopoly Arcade System Information menu

System Details

This screen shows various information an ICE technical support personal might need in supporting your game in the future.

Hardware Monitoring

This screen shows various information an ICE technical support personal might need in supporting your game in the future.

View Game Log

This screen shows the computer log of its activities.

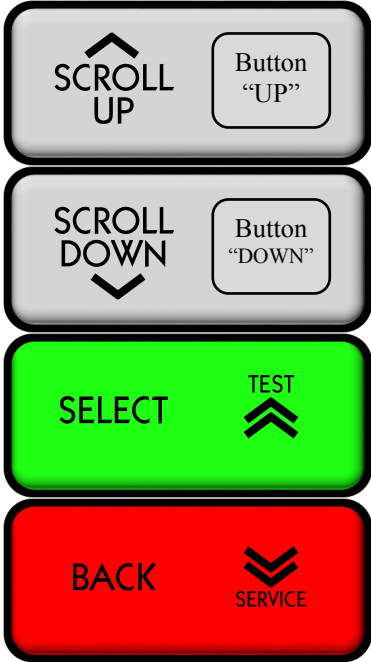
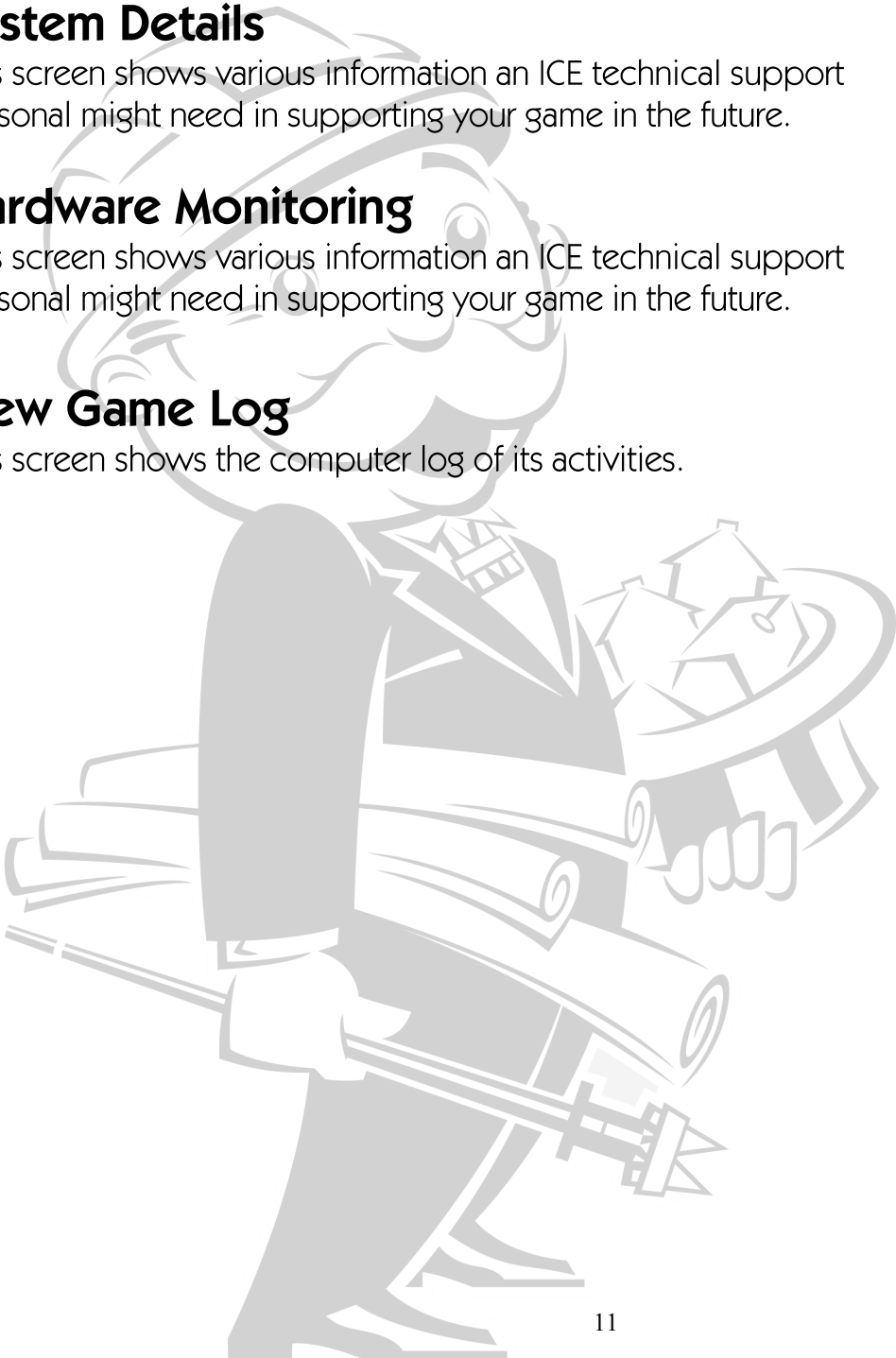



PROGRAM MENUS AND OPTIONS

Monopoly Arcade Tests menu

Input Tests

This test ensures all input devices are working.

Video Tests

This tests the function of your game's monitor.

Coin Meter Test

This test will test the coin meter by advancing it once.

Sound Tests

This test will play audio files to ensure proper operation.

Lamp Test

This test will turn on all lamps.

File Test

This test ensures the files stored on the hard drive are not corrupt.

Ticket Meter Test

This test will advance the ticket meter once.

Watchdog Test

This test will cause a watchdog to occur and reboot the computer.

Ticket Dispenser Test

This will dispense one ticket or coupon.

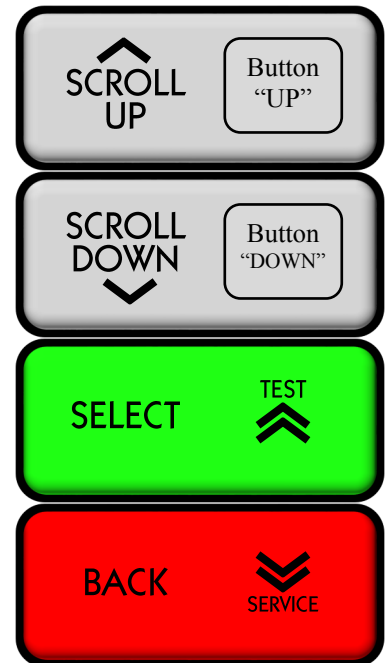



PROGRAM MENUS AND OPTIONS

Monopoly Arcade Utilities menu

Spinner Calibration

This option will allow you to calibrate your spinner. This should be preformed if you replace your spinner.

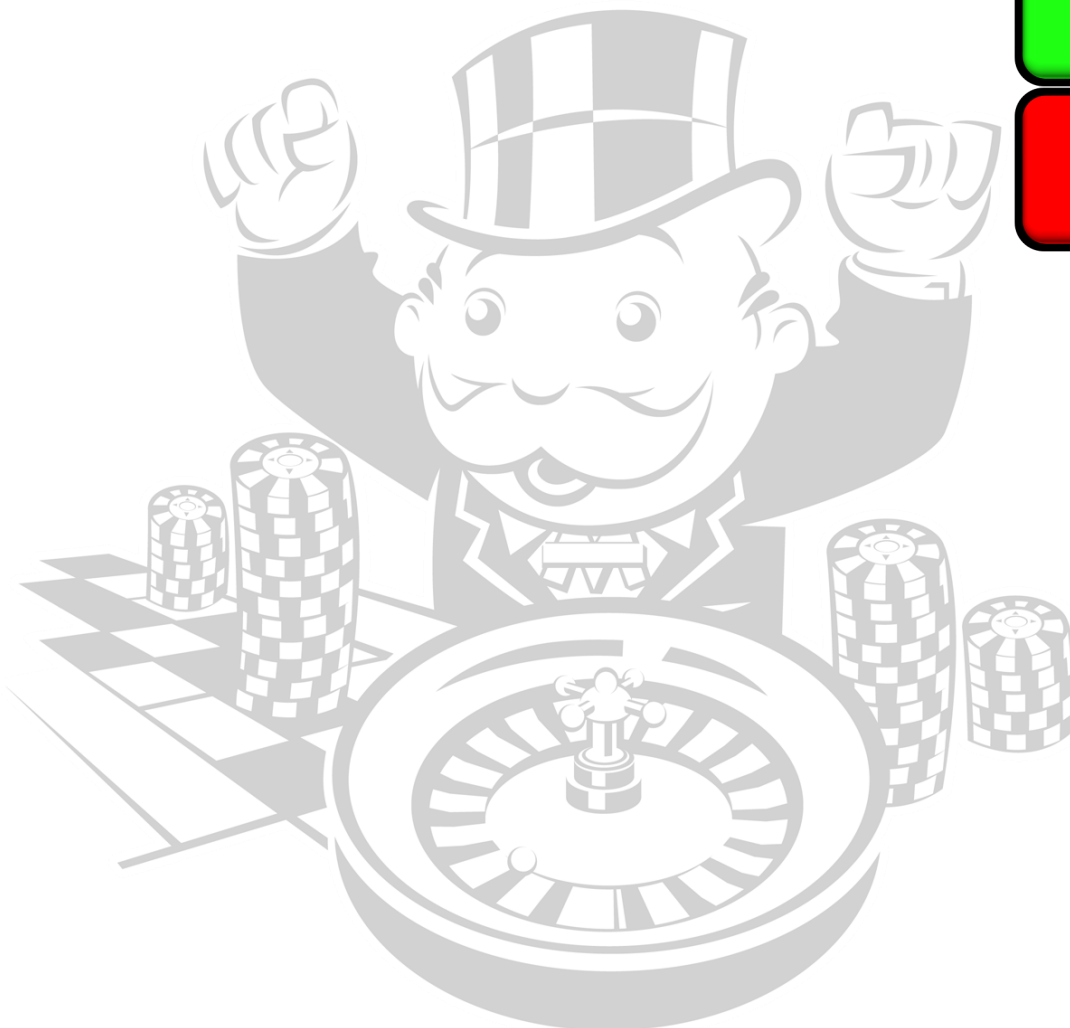
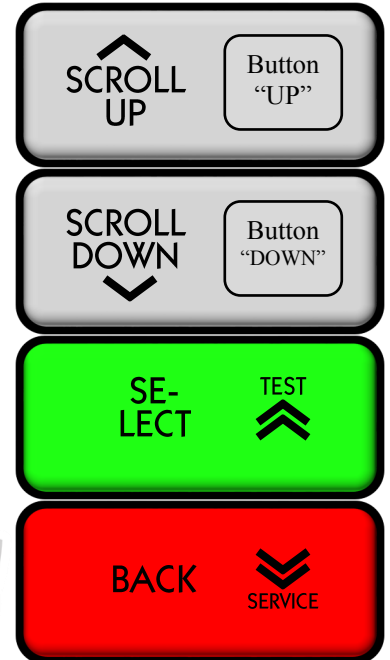

SERVICE

Major component Access

Open the upper coin door and release the two latches that hold the control panel from being opened. Here you will find the computer at the bottom of the cabinet.

To access the I/O board, games' power supply, start button, and spinner, twist the knob clockwise and lower the shelf that is located within the upper control panel.

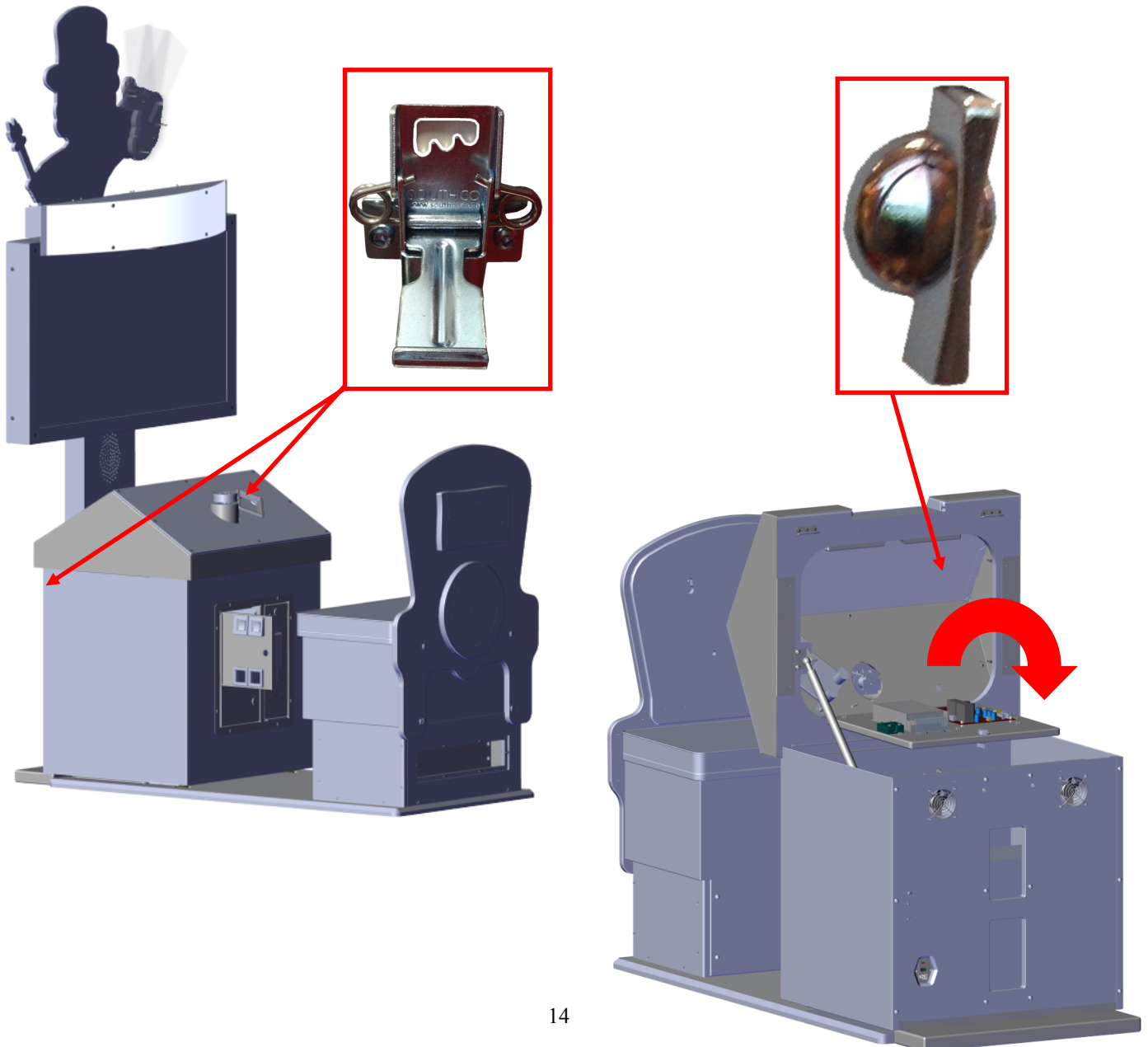

SERVICE

Marquee illumination

To replace the upper marquee's PLL bulb, remove the four screws holding the marquee graphic to the front of the cabinet. Remove the PLL clip and push the red release button.

To replace the upper PLL bulb that lights Mr. Monopoly, remove the six screws holding the top cover. Remove the PLL clip and press the red release button.

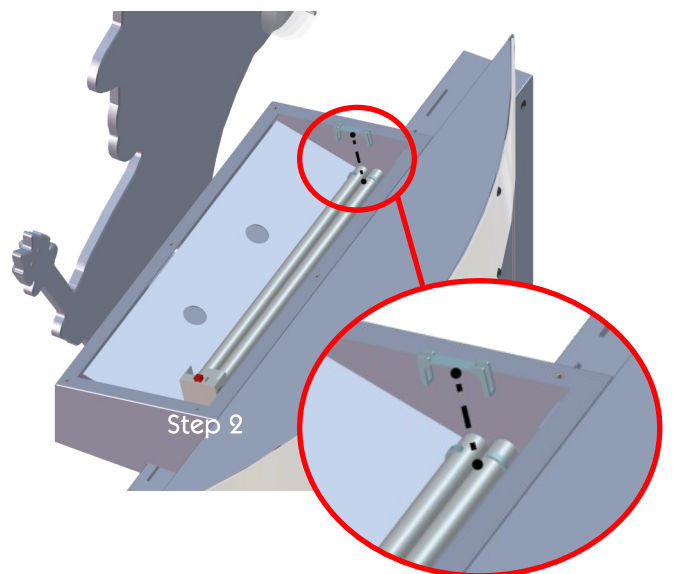
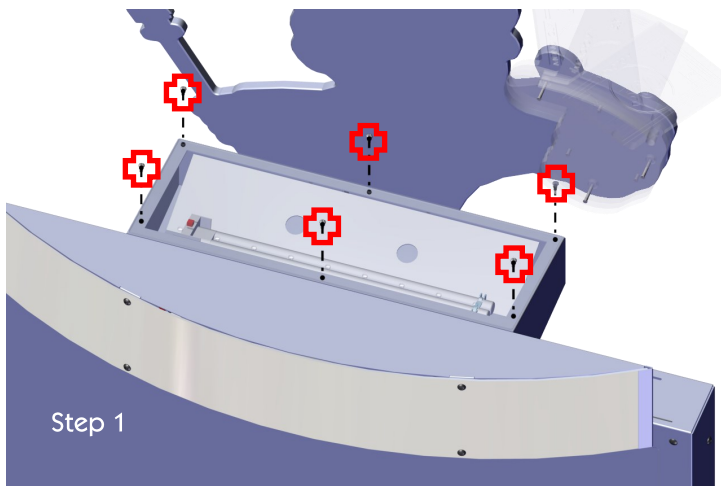
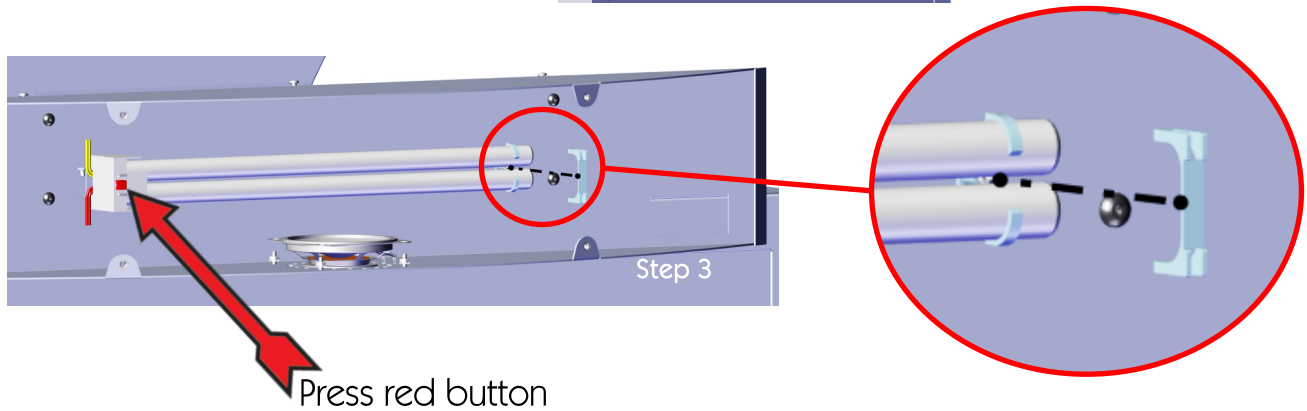
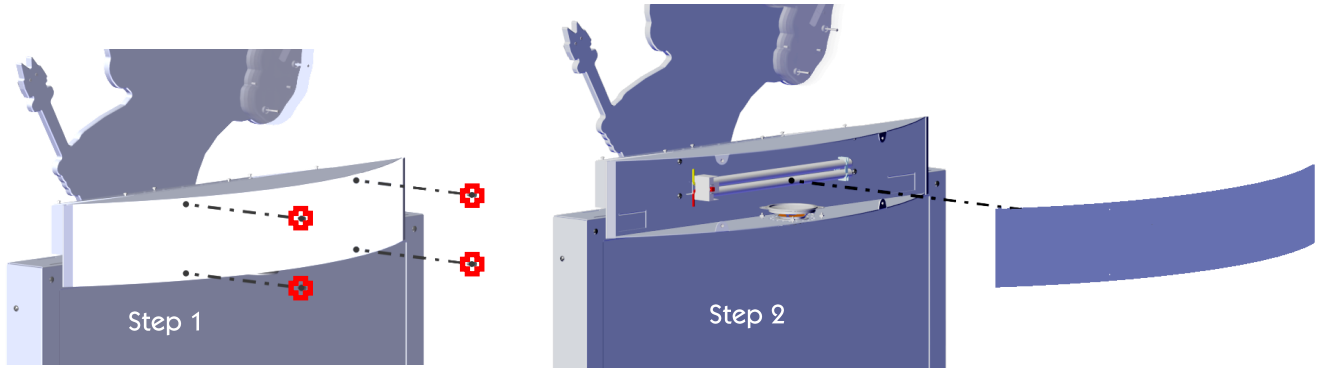

SERVICE

Monitor removal

To replace the monitor you must remove the top marquee assembly first. Remove the four bolts, two on each side, on the top side of the marquee assembly. Remove the back two recessed Allen bolts. Now lift the upper marquee assembly.

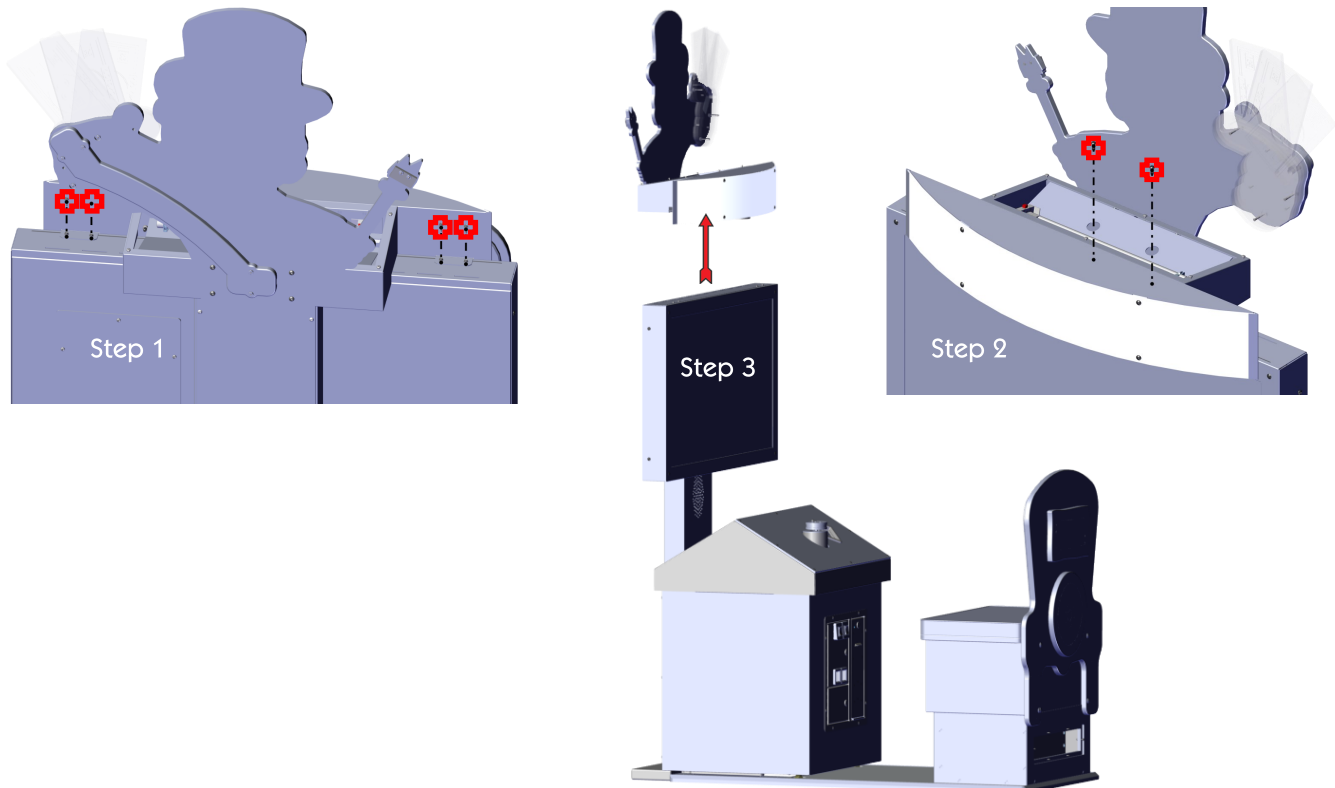

Now remove the four side mounting bolts (two on each side) and the two back bolts.

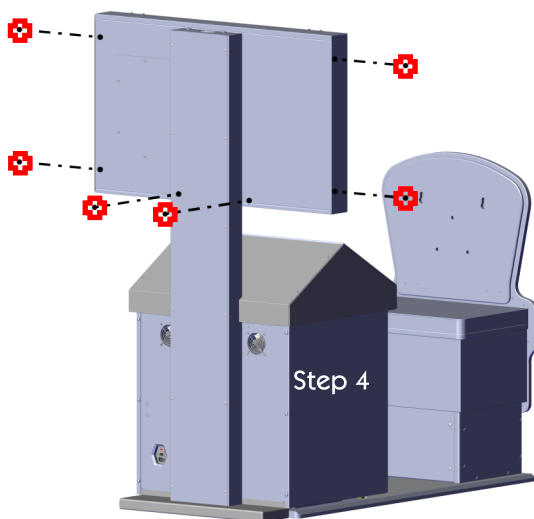

SERVICE

Monitor removal

To replace the monitor you must remove the top marquee assembly first. Remove the four bolts, two on each side, on the top side of the marquee assembly. Remove the back two recessed Allen bolts. Now lift the upper marquee assembly by lifting the bottom out then lift straight up..

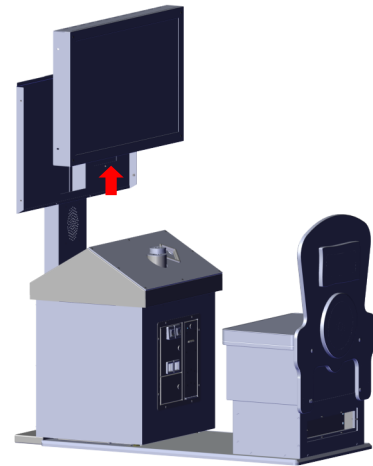
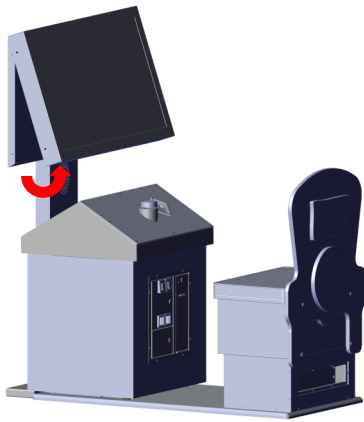

Place the upper monitor assembly down on it's face and remove the four nuts and bolts. It is recommended to use two people to lift the monitor out of the assembly.

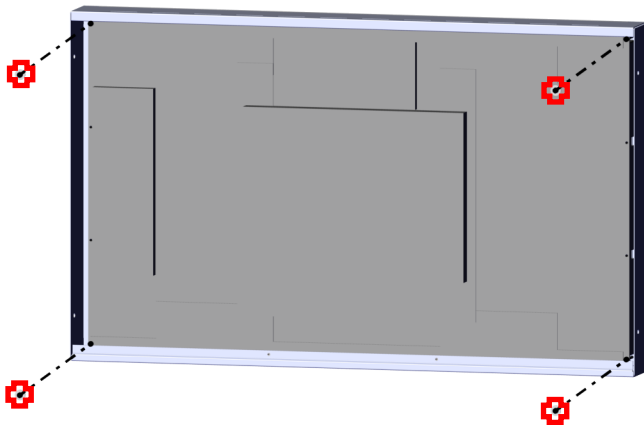

SERVICE

Monitor's power supply removal

To replace the monitor's power supply remove the back of the support bar which holds the monitor and marquee assembly. Now remove the four nuts that hold the power supply to the upper support arm.

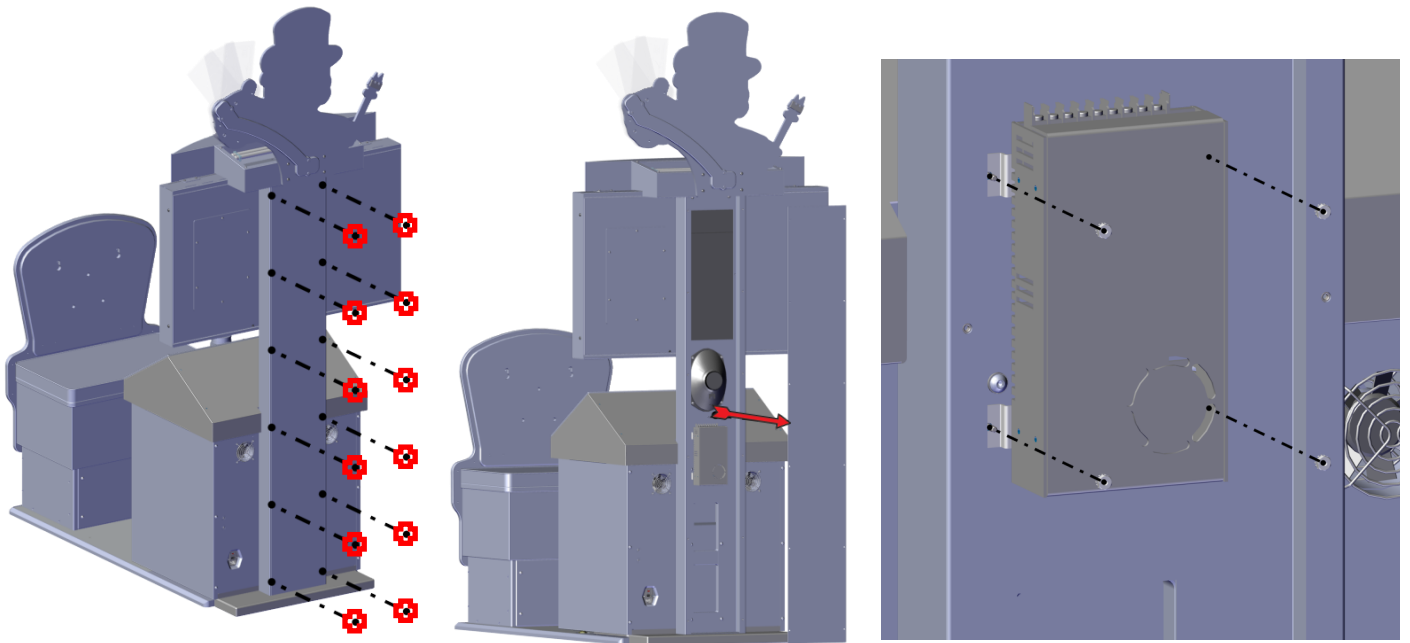

Power supply Specifications

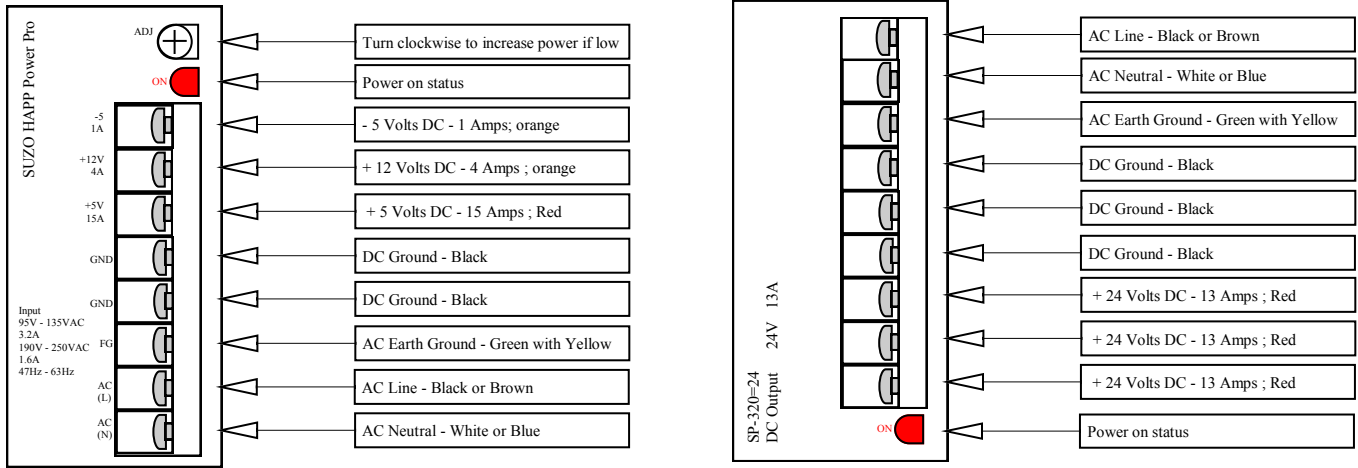

Checking DC Voltages

Volt test with the volt meter set to DC voltage. The +12 output can be adjusted by turning the adjustment screw of the power supply. Adjust to as close to +12 as possible. Increasing the +12. The voltage range can be plus or minus 5%.

Positive Probe:
Connect to +12V on power supply
(orange wire to power supply)

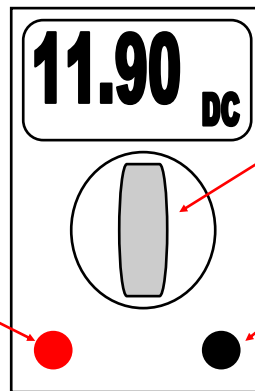

Turn to DC voltage check

Ground Probe:
Connect to GND on power supply

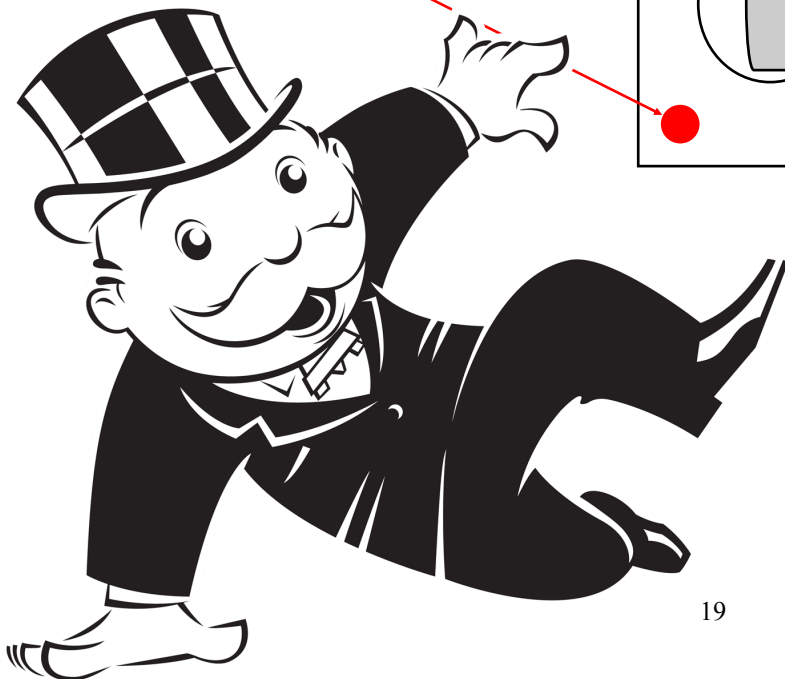



WARRANTY POLICY

I.C.E. Inc warrants all components in new machines to be free of defects in materials and workmanship for the period listed below:

- 180 days on Main PCB's, Computers & Motors
- 1 year on all LCD monitor panels
- 90 days on all other electronic and mechanical components
- 30 days on all I.C.E. repairs and parts purchases

I.C.E. Inc shall not be obligated to furnish a warranty request under the following conditions:

- Equipment or parts have failed through normal wear and tear
- Equipment has been subjected to unwarranted stress, abuse or neglect
- Equipment has been damaged as a result of arbitrary repair/modification

Products will only be covered under warranty by obtaining an I.C.E. authorized RMA #. To obtain an RMA # please provide I.C.E. tech support with the game serial # or original I.C.E. invoice # and a detailed description of the failure or fault symptoms.

I.C.E. Inc will assume no liability whatsoever for costs associated with labor or travel time to replace defective parts. All defective warranty covered components will be replaced with new or factory refurbished components equal to OEM specifications.

I.C.E. Inc will cover domestic UPS ground, or comparable shipping costs during the warranty period. International or expedited shipments are available for an additional charge. To obtain credit defective parts must be returned to I.C.E. Inc, at the customer's expense, within 30 days. After 30 days a 15% re-stocking fee will apply to all returns.

ICE distributors are independent, privately owned and operated. In their judgment, they may sell parts and/or accessories other than those manufactured by I.C.E. Inc. We cannot be responsible for the quality, suitability or safety of any non-I.C.E. part or modification (including labor) that is performed by such a distributor.

Innovative Concepts in Entertainment

10123 Main St.

Clarence, NY 14031

Phone #: (716) - 759 - 0360

Fax #: (716) - 759 - 0884

www.icegame.com