

Jam Session

GUITAR EDITION



Service Manual



PLACE SERIAL NUMBER LABEL HERE

FACTORY CONTACT INFORMATION



BAY TEK GAMES INC.
Pulaski Industrial Park
1077 East Glenbrook Drive
Pulaski, WI 54162 U.S.A.
www.baytekgames.com

Our Vision:

We aspire to be the best in the world at developing and manufacturing coin operated games for our customers.

JOIN SERVICE FIRST NETWORK!

This free service is intended to keep you up to date on the latest game information, early notification of parts specials, pertinent technical bulletins, updates on retro fit parts, software upgrades, & much more. Log on to:
www.baytekgames.com/parts
& then click on the Service First icon.

8 AM - 5 PM C.S.T. MON - FRI

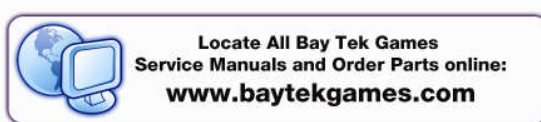

SALES

P: 920.822.3951
F: 920.822.8936
sales@baytekgames.com

PARTS

P: 920.822.3951 x 1101
F: 920.822.1496
parts@baytekgames.com

SERVICE:

P: 920.822.3951 X 1102
F: 920.822.1496
service@baytekgames.com

All games proudly manufactured at our factory in Pulaski, Wisconsin U.S.A.

TABLE OF CONTENTS

FACTORY CONTACT INFORMATION	2
TABLE OF CONTENTS	3
INTRODUCTION	4
INSPECTION	4
JAM SESSION / PART NUMBER	5
SPECIFICATIONS	6
SAFETY PRECAUTIONS	6
HOW TO PLAY	7
MAIN MENU	8
GAME / ATTRACT VOLUME	9
TICKET PATTERNS	10/14
MERCY TICKETS	14
JAMMIN BONUS VALUE	15
JAMMIN BONUS ROUND TIMER	15
JAMMIN BONUS QUANTITY SETTING	16
STATISTICS / CLEAR STATISTICS	17
GAME DIAGNOSTICS	18
NEW JERSEY SETTINGS	19
TROUBLE SHOOTING GUIDE	20/24
DIAGNOSE POWER SUPPLY	25
MAIN BOARD WIRING PINOUT GUIDE	26/27
AUX BOARD WIRING PINOUT GUIDE	28
BACK DISPLAY AND CIRCUIT BOARD WIRING	29
TECHNICAL SUPPORT	30
WARRANTY	31
PARTS LIST	32/33
REPAIR / MAINTENANCE LOG	34
SAFETY CERTIFICATION	35

INTRODUCTION TO JAM SESSION™

Congratulations on your JAM SESSION™ purchase!

We've gone back to our roots and we're more excited than ever to be there! JAM SESSION delivers proven quick-coin game play and is packaged with one of today's hottest themes - Guitar Rock!

Our team has integrated awesome engineering detail into every inch of this game! The LED lighting package is choreographed to the rhythm of the jam, the 3-D marquee plays frets of virtual guitars, the coin ramp chases tokens with RGB lighting effects, and a subtle under-glow sends energetic vibes to players across the room! Players love the moving playfield of bonus targets, so don't be caught off guard when you see them shaking their hips to the music!

We hope you take a few moments to read through this manual, and encourage you to contact the factory with any further questions you may have .

Thank you in advance for your Jam Session purchase and we wish you great success!

Your Friends at Bay Tek Games



GAME INSPECTION

Inspect the game for any damaged, loose, or missing parts. If damage is found, please contact your freight carrier first. Then, contact Bay Tek Games Service Department at 920.822.3951 or e-mail them at service@baytekgames.com for further assistance.

Be sure to complete your new game registration card located inside the cashbox for an additional 3 months FREE WARRANTY!

JAM SESSION / PART NUMBER



Order with: BAYTEK GAMES PART # AAGM-JS

SPECIFICATIONS









WEIGHT	
WEIGHT	245 lbs.
SHIP WEIGHT	290 lbs.
DIMENSIONS	
WIDTH	29"
DEPTH	43.5"
HEIGHT	84"
NORMAL GAME OPERATING TEMPERATURE	
Degrees	75 - 85 F
Degrees	43 - 53 C

POWER REQUIREMENTS			
INPUT VOLTAGE & FREQUENCY RANGE	110 / 120 60 HZ	or	220 / 240 50 HZ

MAX START UP CURRENT
2.5 AMPS @ 115 VAC
1.25 AMPS @ 230 VAC

OPERATING CURRENT
1.3 AMPS @ 115 VAC
1.15 AMPS @ 230 VAC

SAFETY PRECAUTIONS

	DANGER	
<p>DO NOT perform repairs or maintenance on this game with the power ON. Unplug the unit from the wall outlet or shut off the power at the power strip located inside the game cabinet.</p>		
	WARNING	
<p>Use of flammable substances can cause severe burns or serious injury. Always use NON-FLAMMABLE solvents for cleaning. DO NOT use gasoline, kerosene, or thinners. Not suitable for installation in an area where water jet would be used.</p>		
	CAUTION	
<p>Lifting heavy objects can cause back, neck, or other injuries. Be sure adequate lifting and moving devices are available when unloading, unpacking, and moving this game.</p>		
	ATTENTION	
<p>Be sure the electrical power matches the game requirements. See the serial number decal located on the back of the game cabinet. Always plug game into a grounded circuit. If the supply cord is damaged, it must be replaced by a special cord or assembly available from the manufacturer or its service agent.</p>		

HOW TO PLAY: JAM SESSION

Players release tokens into the ramp and are awarded tickets for any target hit on the **inner red wheel**.



Inner Red Wheel



Outer Blue Wheel

PLUS when these targets are hit, the wheel rises up for 20 seconds (selectable) revealing bonus targets on the **outer blue wheel**, worth double tickets!

To top off the excitement, we added a **JAMMIN BONUS!** Hit any Yellow Bonus Target **TWICE** (selectable) on the outer blue wheel and **win up to 1000 tickets!** (selectable)



Jammin' Bonus Display

MAIN MENU

1. Open ticket tray door and locate the **menu** button (*shown to right*)
2. Hold **menu** button down for 6 seconds to enter menu options listed below.
3. Press **menu** button to scroll through each selection.

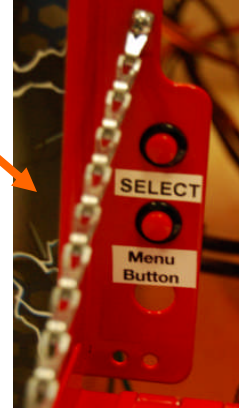

JAM SESSION MAIN MENU SELECTIONS

n1	Game Volume
n2	Attract Volume On or Off
n3	Ticket Pattern Selection
n4	Jammin' Bonus Value
n5	Bonus Round Timer
n6	Mercy Tickets
n7	Number of Times To Hit Jammin' Bonus
n8	Statistics
n9	Clear Statistics
n10	Diagnostics Mode

GAME VOLUME

1. Hold **menu** button down for 6 seconds to enter main menu.
2. Press **menu** button until **n1** is shown on the “TICKETS” display
3. Press **select** button to make volume selection.



Factory Default Setting

low 0 1 2 3 4 5 6 7 high

ATTRACT MODE VOLUME

1. Hold **menu** button down for 6 seconds to enter main menu.
2. Press **menu** button until **n2** is shown on the “TICKETS” display
3. Press **select** button to make attract mode selection.



Factory Default Setting

0 = ATTRACT VOLUME ON **1 = ATTRACT VOLUME OFF**

TICKET PATTERNS

1. Hold **menu** button down for 6 seconds to enter main menu.
2. Press **menu** button until **n3** is shown on the “TICKETS” display
3. Press **select** button to make ticket pattern selection.
Contact Bay Tek’s Parts department if additional ticket value decals are needed.



**Ticket Pattern 1 is
Factory Default Setting**



ADDITIONAL TICKET PATTERNS

PATTERN 2



PATTERN 3



ADDITIONAL TICKET PATTERNS

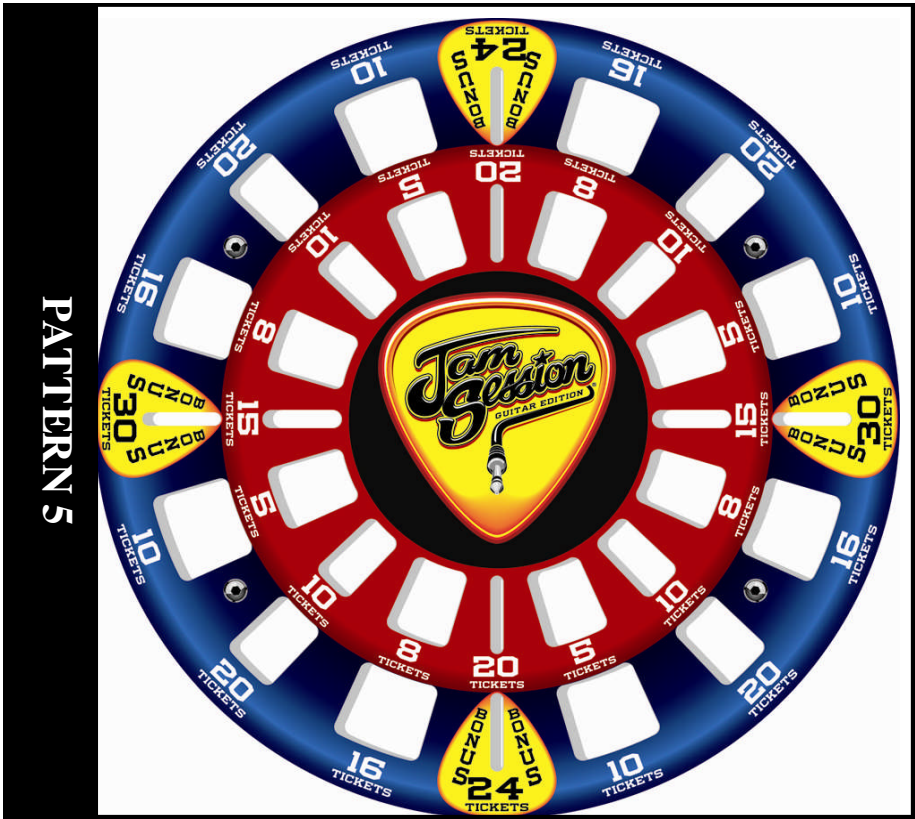
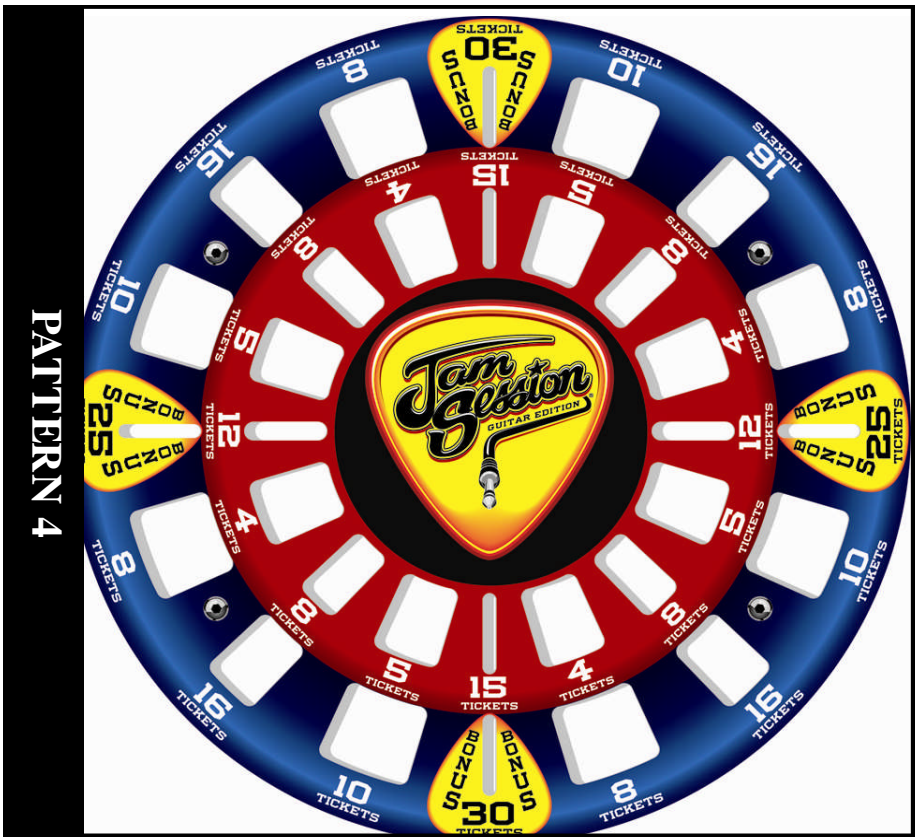

ADDITIONAL TICKET PATTERNS



ADDITIONAL TICKET PATTERNS

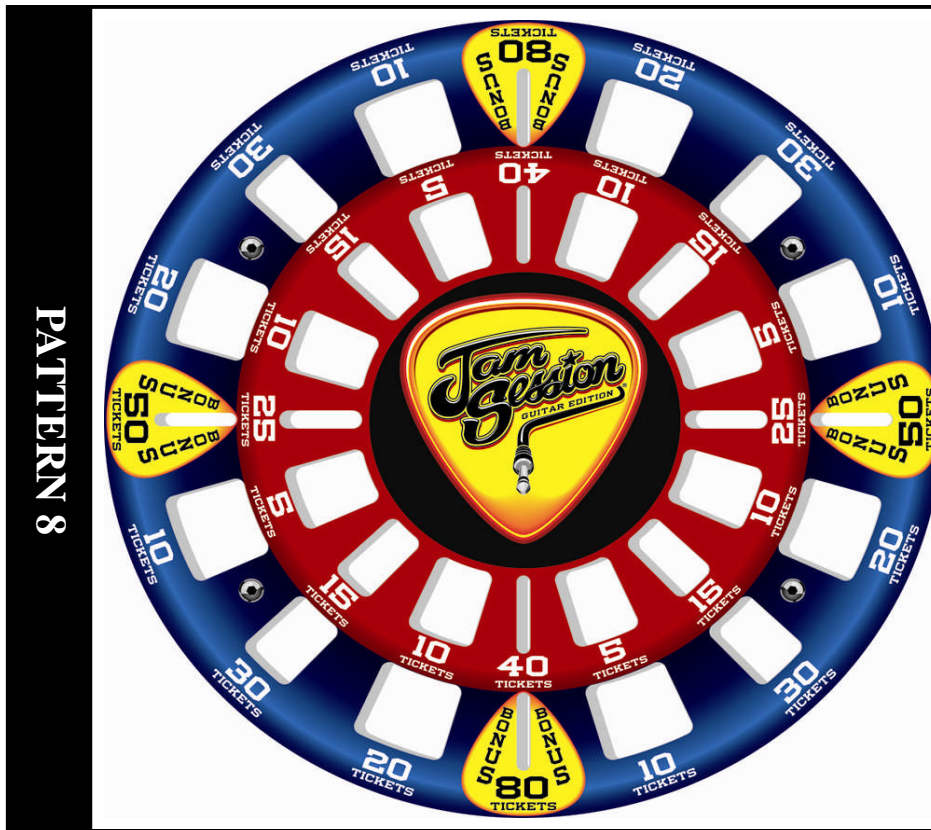

Contact Bay Tek Games Parts Department at (920) 822-3951 x1101 for replacement decal sheets should you make a change to the existing ticket pattern.

MERCY TICKETS

1. Hold **menu** button down for 6 seconds to enter main menu.
2. Press **menu** button until **n6** is shown on the “TICKETS” display
3. Press **select** button to make mercy ticket selection.



Factory Default Setting

0 1 2 3 4 5

Mercy Tickets are quantity of tickets dispensed per game regardless of a target being hit.

JAMMIN' BONUS VALUE

1. Hold **menu** button down for 6 seconds to enter main menu.
2. Press **menu** button until **n4** is shown on the "TICKETS" display
3. Press **select** button to make JAMMIN bonus selection (shown on large 4-segment display on guitar marquee)



Factory Default Setting

50 150 250 500 **1000** 2000

The JAMMIN' Bonus is the number of tickets awarded when players hit a yellow bonus target on the outer blue wheel two times (selectable /see n7)



BONUS ROUND TIMER

1. Hold **menu** button down for 6 seconds to enter main menu.
2. Press **menu** button until **n5** is shown on the "TICKETS" display
3. Press **select** button to make bonus time selection.



Factory Default Setting

7 seconds 14 seconds **20 seconds** 25 seconds

The **Bonus Round Timer** refers to the length of time the blue bonus targets are exposed to the player before the wheel returns to home position where only red inner targets are exposed to players.



NUMBER OF TIMES TO HIT JAMMIN' BONUS

1. Hold **menu** button down for 6 seconds to enter main menu.
2. Press **menu** button until **n7** is shown on the "TICKETS" display
3. Press **select** button to make JAMMIN bonus hits selection



Factory Default Setting

1 2 3 4

Number of Times To Hit JAM BONUS is the number of times a player must hit any yellow target on the outer blue wheel to win the big JAMMIN' BONUS displayed on center of the guitar marquee on the 4-segment display.



STATISTICS

Statistics

S1	Total Games Played
S2	Total Tickets (Number / 100)
S3	Big Bonus Tickets
Round 1 Hits	
S4	Hits for Slots 0 and 8
S5	Hits for Slots 1 and 9
S6	Hits for Slots 2 and 10
S7	Hits for Slots 3 and 11
S8	Hits for Slots 4 and 12
S9	Hits for Slots 5 and 13
S10	Hits for Slots 6 and 14
S11	Hits for Slots 7 and 15
S12	Round 1 Misses
Round 2 Hits	
S13	Hits for Slots 0 and 8
S14	Hits for Slots 1 and 9
S15	Hits for Slots 2 and 10
S16	Hits for Slots 3 and 11
S17	Hits for Slots 4 and 12
S18	Hits for Slots 5 and 13
S19	Hits for Slots 6 and 14
S20	Hits for Slots 7 and 15
S21	Round 2 Misses

To View Game Statistics:

1. Hold **menu** button down for 6 seconds to enter main menu.
2. Press **menu** button until **n8** is shown on the “TICKETS” display.
3. Press **select** button until **s1** appears in the “TICKETS” display.
4. Press **select** button to view data. (see chart to left)



Slot Location Diagram

To Clear Statistics:

1. Hold **menu** button down for 6 seconds to enter main menu.
2. Press **menu** button until **n9** is shown on the “TICKETS” display.
3. Then press **select** button until **DON** is shown in “TICKETS” display.

GAME DIAGNOSTICS

To Enter Diagnostics:

1. Hold **menu** button down for 6 seconds to enter main menu.
2. Press **menu** button until **n10** is shown on the “TICKETS” display.
3. The encoder wheel **slot location** is displayed in the right “BONUS TIMER” display, while the corresponding **ticket value** is displayed in the “TICKETS” display. If the values displayed on the bonus timer do not match your wheel—there may be a slot sensor and/or encoder issue.



TICKET VALUE DIAGRAM



WHEEL SLOT DIAGRAM

STATE OF NEW JERSEY SETTINGS

Fixed Ticket Payout

P1 = 5
P2 = 6
P3 = 7
P4 = 8
P5 = 9
P6 = 10
P7 = 11
P8 = 12

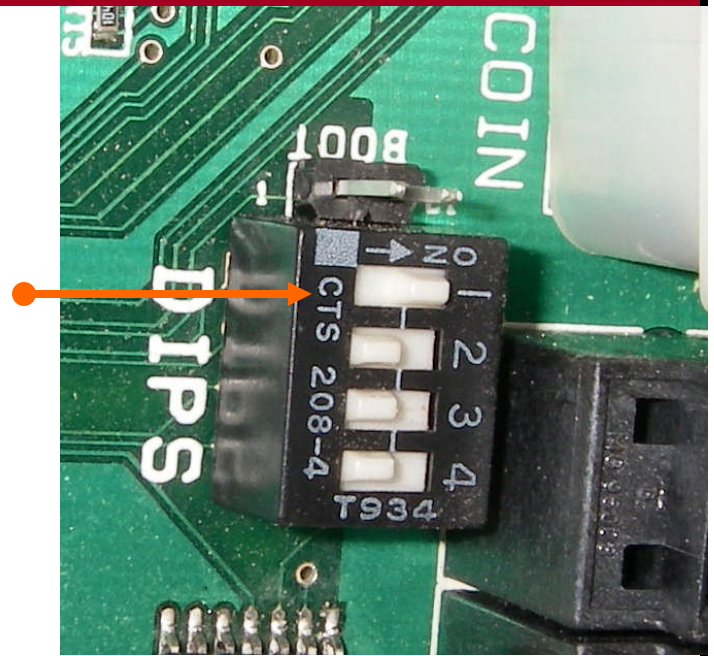

FIXED TICKET PAYOUT = DIP 1 / ON

Power Loss Memory

In the event that the power is lost during ticket payout, the game can store the unpaid amount and continue the payout once power is restored.

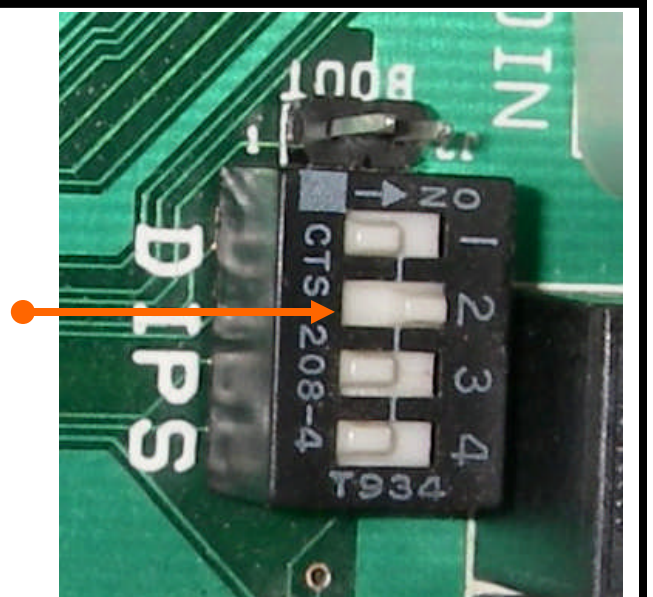

POWER LOSS MEMORY = DIP 2 / ON

TROUBLE SHOOTING GUIDE

Troubleshooting Strategy

Use common sense and a systematic method of troubleshooting to determine the exact problem, probable cause and remedy. Use the process of elimination to find the faulty component. Always check for the simple and obvious causes first such as unplugged, loose or broken wires and bad sensors, bent, pinched, stuck or jammed components.

Error Code	Probable Cause	Remedy
Err 01	Ticket Jam	Clear tickets. Re-feed through dispenser making sure tickets pass through opto eye on dispenser. Refer to Tickets Do Not Dispense below.
Lo 02 Low or no tickets in ticket tray.	Low or no tickets in ticket tray.	Add tickets, replace switch, and check wiring from main board to switch. Refer to Tickets Do Not Dispense below.
Err 04 Coin Sensor Fault – Game is reading coin at Slot Sensor Board at wrong time.	Coin is not triggering coin switch. Misalignment of sensors. The green LED should normally be off. Faulty sensor board.	Coin switch must sound before coin is allowed to score. Check all emitters and detectors for proper alignment. Bend by hand. Refer to Game Does Not Score below.
Err 20 Lifter Problem	Lifter sensor faulty. Lift motor faulty. Faulty Cable	Check for lifting at power on. Ensure nothing binding on assembly. Refer to Wheel Not Lifting below.
Err 40 Wheel Speed Fault.	Faulty Motor Cam slipping on motor shaft.	Ensure set screw is tight on motor shaft. Refer to Wheel Not Rotating below.
Err 80 Game Not Reading Wheel.	Wheel position sensor faulty. Silver code wheel decal not reflective.	Check for power to sensor, clean sensor and silver code decal. Refer to Diagnosis Code Wheel below.

TROUBLE SHOOTING GUIDE

Troubleshooting Strategy

Use common sense and a systematic method of troubleshooting to determine the exact problem, probable cause and remedy. Use the process of elimination to find the faulty component. Always check for the simple and obvious causes first such as unplugged, loose or broken wires and bad sensors, bent, pinched, stuck or jammed components.

	Probable Cause	Remedy
No power to the game.	Unplugged. Circuit breaker tripped. Power supply unplugged. Power supply shutting down because of 12 V overload. Bad power supply.	Check wall outlet. Reset power strip switch or building circuit breaker. Insure unit is plugged into power strip. See power supply diagnostics to isolate bad component. A bad motor or 12 volt short would cause this.
No Audio	Volume too low. Loose wire at control or speaker. Main circuit board malfunction.	Increase the volume by entering menu. N1 sets game volume. N2 sets attract mode on and off. Press and hold red menu button down to enter menu. Press select button to change settings. Check audio cable connections to speaker, and main circuit board. Cable # AACE9203. Check continuity. Replace main board with board from another game if possible to isolate the problem to the main circuit board.
Fluorescent Lighting not functioning properly.	Fixture unplugged. Lamp out.	Plug power cable into power strip. Replace compact fluorescent bulb. (A5LI0001)
Part of a display is not showing.	Segment faulty.	Replace display board. Refer to circuit board wiring diagram to identify board.
Upper displays not functioning properly.	Displays frozen. Previous board in line faulty.	Display boards are "daisy chained" together. Check the "Out" socket from previous display, cable, and "In" socket on suspect board.

TROUBLE SHOOTING GUIDE

Troubleshooting Strategy

Use common sense and a systematic method of troubleshooting to determine the exact problem, probable cause and remedy. Use the process of elimination to find the faulty component. Always check for the simple and obvious causes first such as unplugged, loose or broken wires and bad sensors, bent, pinched, stuck or jammed components.

Wheel not rotating. Check for 11 Volts DC within the first 5 seconds after power-up.	11 Volts ok but motor does not turn.	Faulty motor.	Replace motor. (A5MO4010)
	11 Volts ok, motor turns, but stops after 5 seconds.	Wheel position sensor faulty.	Refer to Diagnosis Code Wheel
	11 Volts not present.	Wheel position sensor faulty. Cable problem. Faulty Aux Board. Faulty Main Board.	Replace wheel position sensor. (AACB1451) Check cable (ACE9206) from sensor to Aux board. Check cable (ACE9200) from Aux board to main board. Swap cables to verify. Check solder connections and clean phone jack sockets on Aux Board. Replace main board.
Wheel not lifting. (Error 20) At game power on, wheel raises and lowers. Check for 12 Volts DC on motor at power on.	12 Volts ok, but motor does not rise.	Faulty Motor.	Replace motor. (A5MO4010)
	12 Volts not present.	Faulty Cable Faulty Lift Sensor Board. Faulty Aux Board. Faulty Main Board.	Check cable (ACE9214), clean phone connector sockets. Replace Lift Sensor Board. (AACB1455) Check solder connections and clean phone jack sockets on Aux Board. Replace main board.
Wheel lifts at power up, but does not come back down correctly.	Sensor is "seeing" home position too soon. Wheel pauses as it lifts. Mechanical jam in Assy. Faulty sensor.	Sensor should only reflect off metal cam. Ensure that wood lifter is dull and not reflective. Cam too close to sensor. Back the cam away 1/16 inch. Remove cam from motor and manually raise and lower wheel, making sure it slides freely. Replace Sensor. (AACB1455)	
Wheel is always going up and down. (Error 20)	Lift sensor not seen. Faulty lift sensor. Faulty Cable Faulty Aux Board. Faulty Main Board.	Clean sensor and shiny reflective cam. (A5CA4100) Swap board from other side. Replace if needed. (AACB1455) Check cables (ACE9214), clean phone connector sockets. Check solder connections and clean phone jack sockets on Aux Board. Replace main board.	

TROUBLE SHOOTING GUIDE

<p>Game doesn't score.</p> <p>Check for coin up sound at coin dropping through coin mech.</p>	<p>No coin up sound</p>	<p>Switch bad in coin mech. Disconnected, loose or broken wires.</p> <p>No game sound.</p>	<p>Replace coin mech. (A5CM-AS-COMP) Check connectors. Check for continuity. Clean phone cable sockets. Cable #'s : AACE1527, AACE9201</p> <p>Go to No Audio section.</p>
<p>Yes – Coin up sound</p>	<p>Yes – Coin up sound</p>	<p>Coin taking too long to get to sensor board. Slot sensor board not seeing coin. Faulty cable. Faulty Aux Board. Slot sensor board bad.</p>	<p>Clean ramp. Ensure coin passes from coin mech to ramp cleanly. Green LED should be OFF normally. It comes ON when sensor is blocked. Check cable - AACE9214. Clean phone connector sockets. Clean & replace if needed. (AACB9200) Replace chip. (ULN2803) Replace board. (AACB1452)</p>
<p>Game scores wrong values</p>		<p>Game is scoring too soon – before coin reaches Slot sensor board. Wheel is not rising after any win. Wheel position decal scratched. Check menu settings..</p>	<p>Slot sensor board is bad – Align/clean sensors, replace chip, or replace board. (AACB1452) Wheel will score double, even if wheel does not rise. Refer to Wheel not Lifting section. Replace wheel decal. (A5DC4103) Check menu settings.</p>
<p>Tickets do not dispense or Wrong amount dispensed.</p> <p>Check for the correct amount of tickets adding up on Tickets Owed Display</p>	<p>Tickets Owed Display is adding up correct.</p>	<p>Opto Sensor on ticket dispenser dirty. Faulty ticket dispenser. Notch on tickets cut too shallow. Faulty cable.</p> <p>Faulty Main Board.</p>	<p>Blow dust from sensor and clean with isopropyl alcohol. Replace with working dispenser to isolate the problem. (A5TD1) Flip tickets and load upside-down to have large cut notch toward opto sensor. Check cables 1615 9205, from ticket dispenser to J5 on main board Replace main board.</p>
<p>Tickets Owed Display is not adding correctly</p>	<p>Tickets Owed Display is not adding correctly</p>	<p>a. Check menu settings. b. Game is scoring too soon – before coin reaches Slot sensor board.</p>	<p>Check settings on main board. Check menu settings. Slot sensor board is bad – Align/clean sensors, replace chip, replace board. (AACB1452)</p>

TROUBLE SHOOTING GUIDE

Diagnose Code Wheel

The silver code wheel decal, attached to the back side of the wheel, must work properly to identify slot location and ticket payout.

To check for proper operation;

Press and hold red menu button down to enter menu.

Continue pressing menu button as display cycles up through N #'s. Stop at N10.

The right side display will count up from zero to 16.

The left side display will show ticket value associated with the slots.

If a slot number is skipped as the wheel rotates past the coin slot hole, the wheel position sensor (AACB1451) is not reading the silver code wheel decal (A5DE4103)

Clean the decal and sensor and retest. Replace the wheel assembly if needed.

The game will automatically exit diagnostics.

Error 80 - Wheel not being seen.	Dirty sensor or decal. Ripped or dull silver decal. No power to sensor board Faulty sensor board. Faulty cable.	Remove wheel and clean optos and silver decal on back of wheel. Replace decal. (A5DE4103) Insure green LED on board is ON. Replace wheel position sensor. (AACB1451) Check cables AACE9206 going to Aux board, and AACE9200 going to main board. Clean phone connector sockets.
----------------------------------	---	---

DIAGNOSE POWER SUPPLY

Use the following procedure to check the power supply.

Check the small green LED light on the power supply circuit board. If the light is out there is a short somewhere. If the light dims, there is an overload in one of the circuits, such as a bad connection.

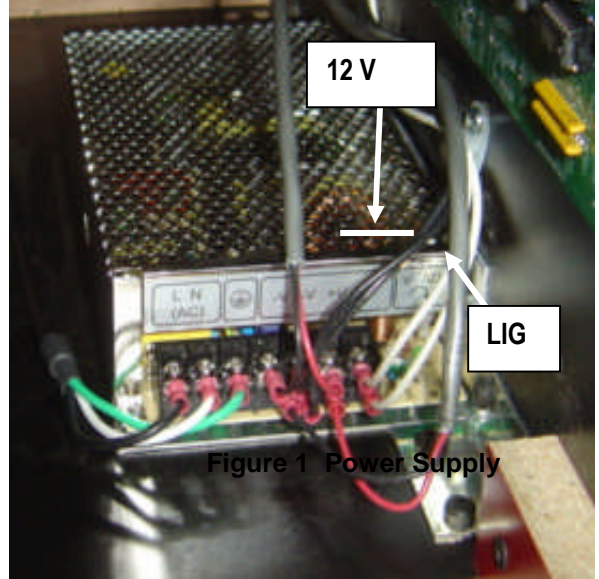
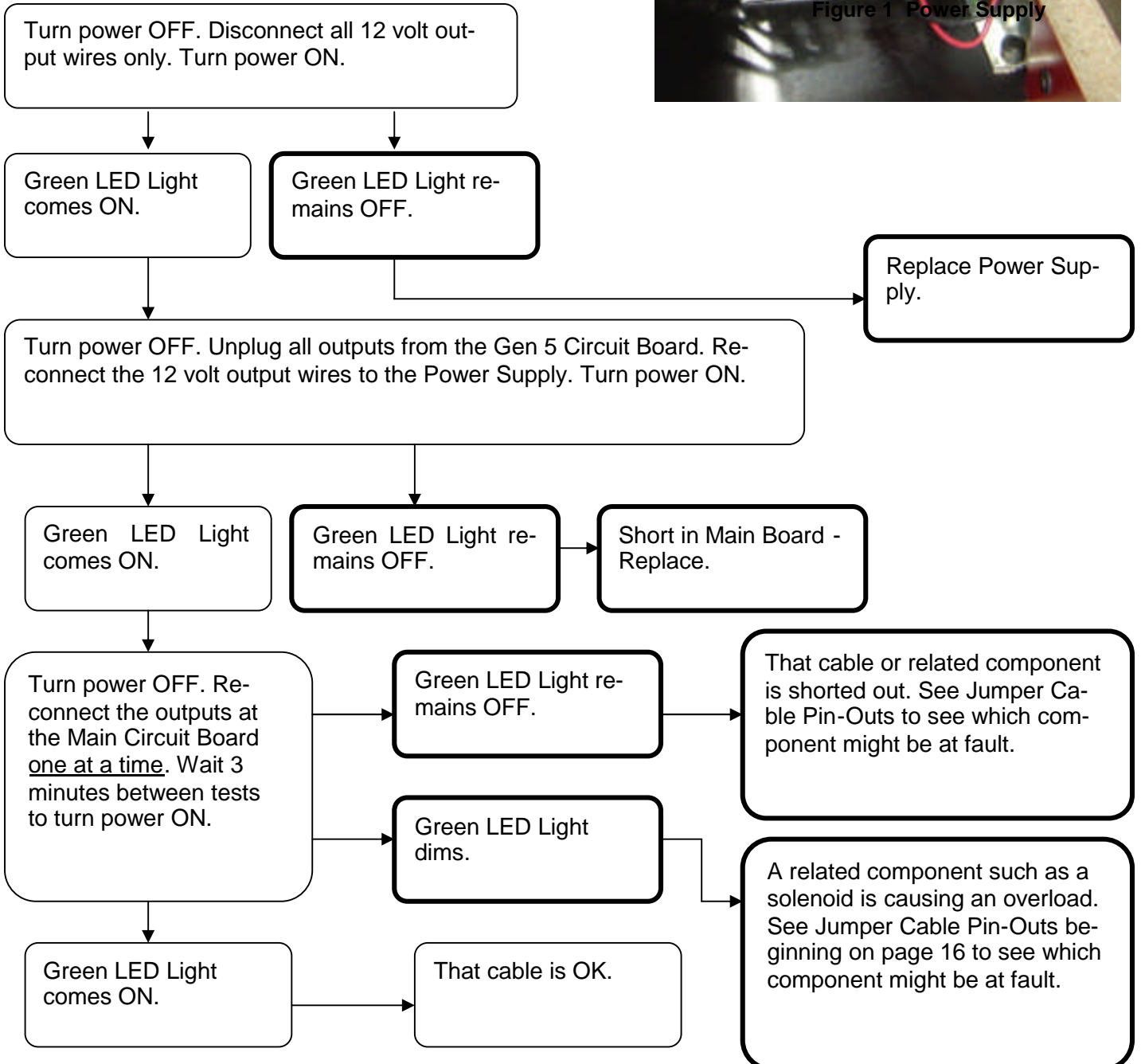

Figure 1 Power Supply



MAIN BOARD WIRING PINOUT

(Part # AANEWGEN1)

J22 – AACE9201
Counters and Color
Lighting

J25 – AACE9202
Menu and Select
Buttons

J18 –
AACE4502
Power In
from Power
Supply

J6 – AACE9201
Coin Mech

J11 & J12
AACE9208
Chase
Lights

J10 – AACE4211
To Displays

AACE9203
Speakers

J21 – AACE9200 to Aux
Board Components

J25 –
AACE9200
Ramp Lights

J9 – AACE9205
Low Ticket Switch

J5 – AACE9205
Ticket Dispenser

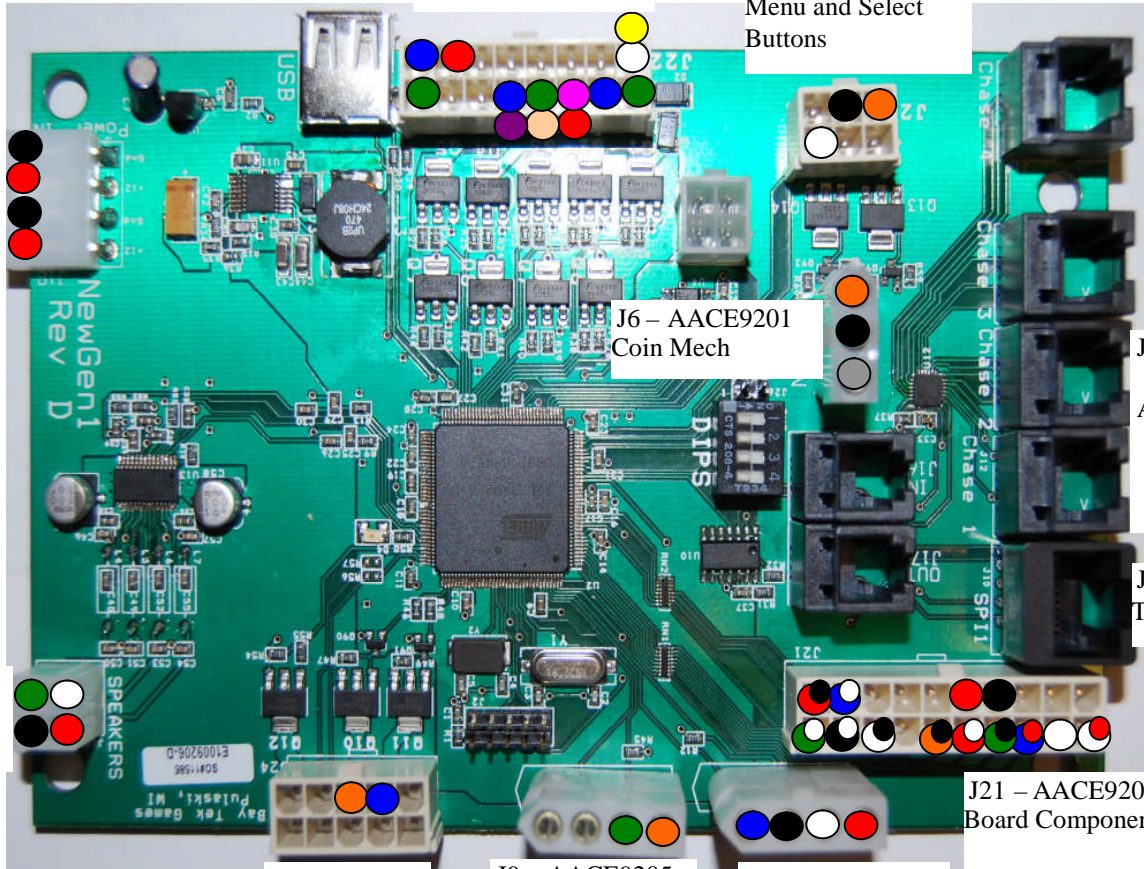

MAIN BOARD PINOUT

Pin Type	Purpose	Ref	Pin #
LOWSIDE #1, w diode	Wheel Motor (aacb1451 pin 5)	J22	1
LOWSIDE #2, w diode	Wheel Level Motor (aacb1455 pin 4)	J22	2
LOWSIDE #3	Acrylic Lighting RED Color	J22	3
LOWSIDE #4	Acrylic Lighting GREEN Color	J22	4
LOWSIDE #5	Acrylic Lighting BLUE Color	J22	5
LOWSIDE #7	Unused	J22	7
LOWSIDE #8	Mech Count 1	J22	8
LOWSIDE #9	Mech Count 2	J22	9
+12 Volts		J22	11
+12 Volts		J22	12
+12 Volts		J22	13
+12 Volts		J22	14
+12 Volts		J22	15
+12 Volts		J22	16
+12 Volts		J22	17
+12 Volts		J22	18
+12 Volts		J22	19
+12 Volts		J22	20

HIGHSIDE #13		J25	1
HIGHSIDE #14		J25	2
PX10	Service Button #1	J25	3
PX11	Service Button #2	J25	4
Ground	Ground for Service Buttons	J25	5
Ground	Ground for Mech. Counters	J25	6

+12 Volts	Coin Door Power	J6	1
PA05	Coin Input	J6	2
Ground	Coin Ground	J6	3

3	Wheel Level Stop Sensor Input	J21	1
PX39	Guitar Handle Latch to 9100 board	J21	2
PX00	Ramp Latch to 9100 board	J21	3
PX01	Ramp Clock to 9100 board	J21	4
PB20	Slot Coin Sensor	J21	5
PX02	Ramp Data To 9100 board	J21	6
PB21		J21	7
PB22	Wheel Encoder #1 (Home)	J21	8
PB23	Wheel Encoder #2	J21	9
PB24	Guitar #1 Handle Data to 9100 board	J21	10
Ground		J21	11
Ground		J21	12
Ground		J21	13
Ground		J21	14
+12 Volts		J21	15
+12 Volts		J21	16
+12 Volts		J21	17
+12 Volts		J21	18
PB25	Guitar #2 Handle Data to 9100 board	J21	19
PB26	Guitar Handle Clock to 9100 board	J21	20

=Low Side Driver
=High Side Driver
= TTL Input/Output
= LED Constant Current Drive
= 12 Volts
= Ground

Pin Type	Purpose	Ref	Pin #
Ground		J24	1
Ground		J24	2
+12 Volts		J24	3
+12 Volts		J24	4
PB7	Unused	J24	5
LOWSIDE #12	Unused	J24	6
PX29	Unused	J24	7
HIGHSIDE #10	TO AACB9100	J24	8
HIGHSIDE #11	TO AACB9100	J24	9
3.3V		J24	10

PX37	Ticket Notch #1	J5	1
Ground	Ground for Ticket Dispensor	J5	2
PB18	Ticket Motor #1	J5	3
+12 Volts	Power for Ticket Dispensor	J5	4

PB16	Low Ticket Switch	J9	1
Ground	Ground for Low Ticket Switch	J9	2
PB17	Unused	J9	3
+12 Volts		J9	4

PA06	DBA Input	J8	1
+12 Volts		J8	2
Ground		J8	3
Ground		J8	4

Driver 1	To AACB9101 Speaker Chase Lights	J12	1
Driver 2	To AACB9101 Speaker Chase Lights	J12	2
+12 Volts	To AACB9101 Speaker Chase Lights	J12	3
Driver 3	To AACB9101 Speaker Chase Lights	J12	4
Driver 4	To AACB9101 Speaker Chase Lights	J12	5
+12 Volts	To AACB9101 Speaker Chase Lights	J12	6

Driver 5	To AACB9101 Speaker Chase Lights	J11	1
Driver 6	To AACB9101 Speaker Chase Lights	J11	2
+12 Volts	To AACB9101 Speaker Chase Lights	J11	3
Driver 7	To AACB9101 Speaker Chase Lights	J11	4
Driver 8	To AACB9101 Speaker Chase Lights	J11	5
+12 Volts	To AACB9101 Speaker Chase Lights	J11	6

Driver 9		J13	1
Driver 10		J13	2
+12 Volts		J13	3
Driver 11		J13	4
Driver 12		J13	5
+12 Volts		J13	6

Driver 13		J14	1
Driver 14		J14	2
+12 Volts		J14	3
Driver 15		J14	4
Driver 16		J14	5
+12 Volts		J14	6

AUX BOARD WIRING PINOUT

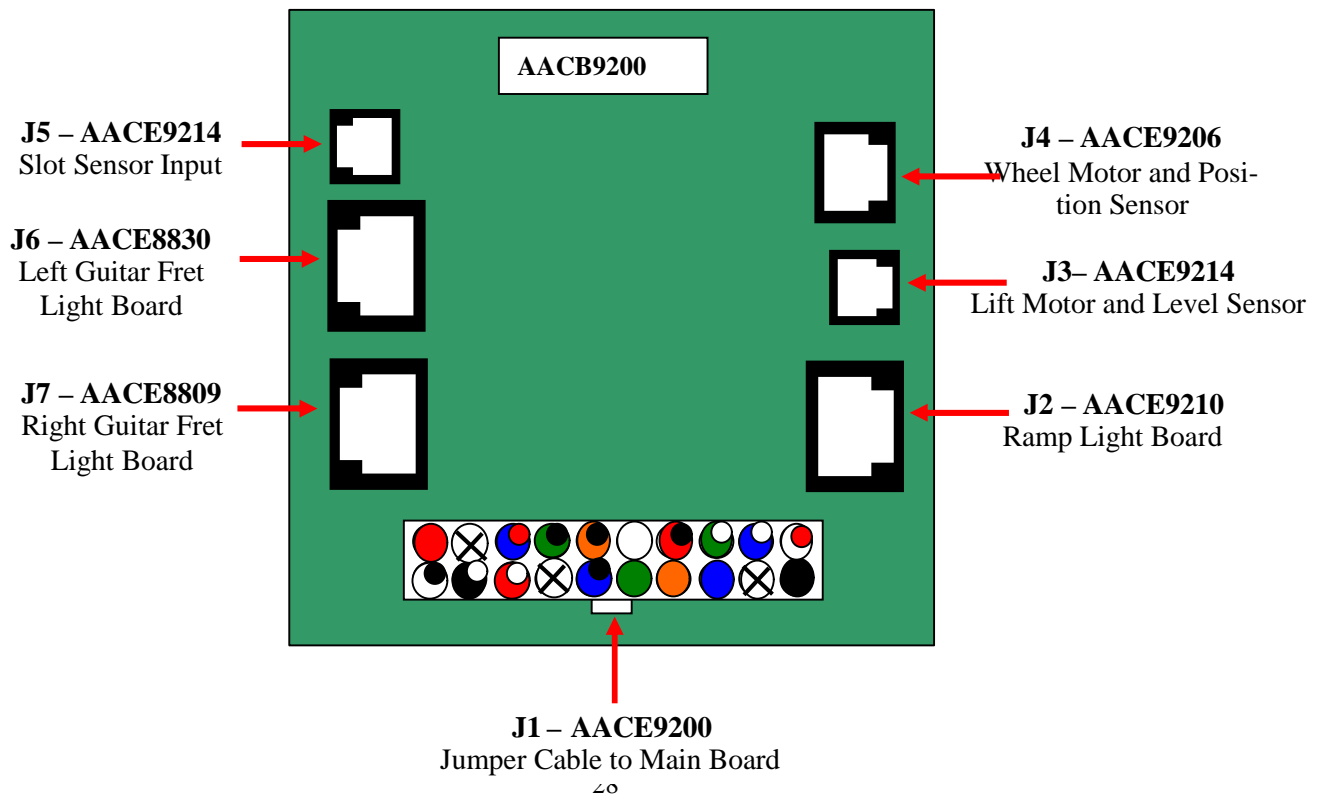
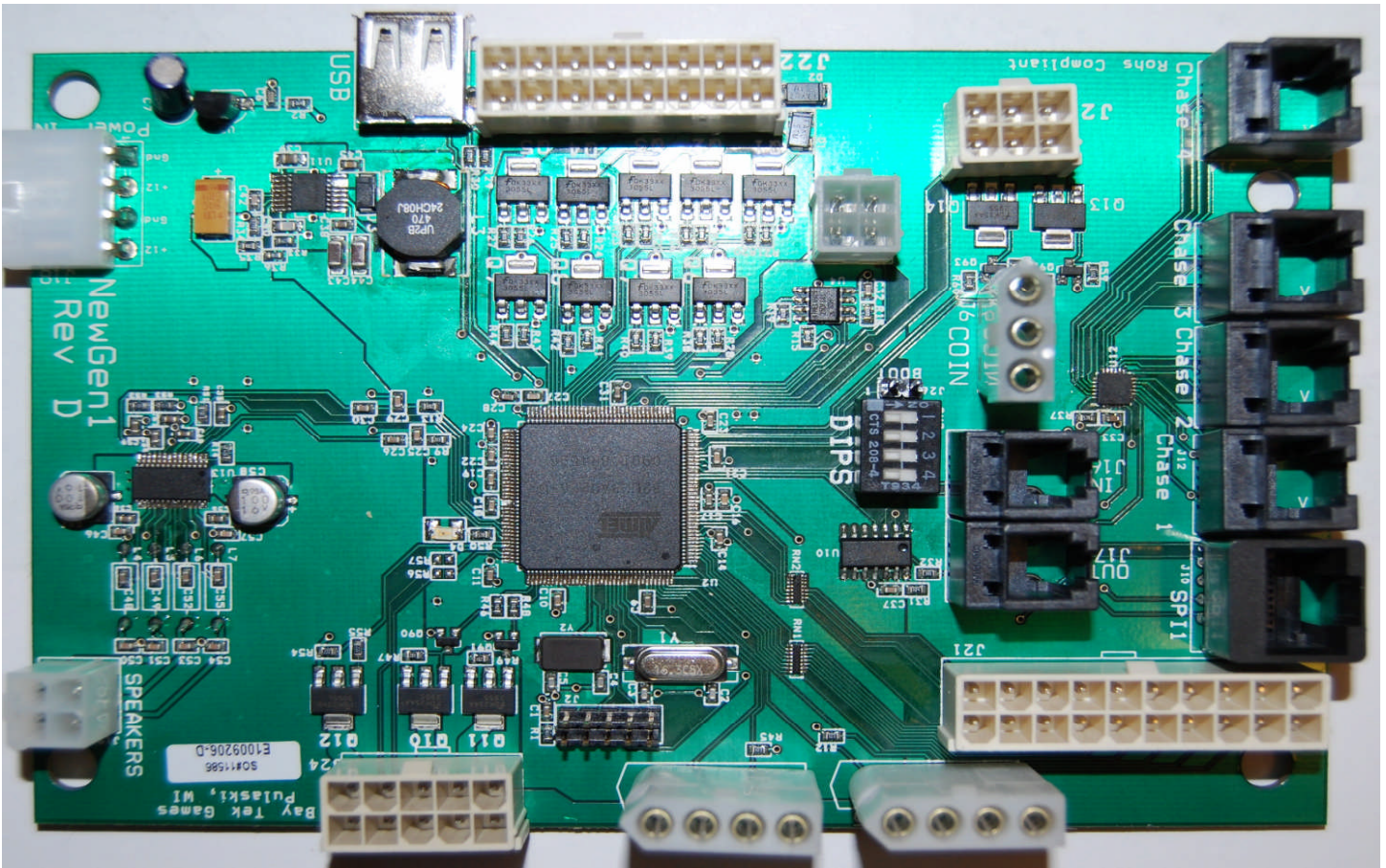

Back Display and Circuit Board Wiring

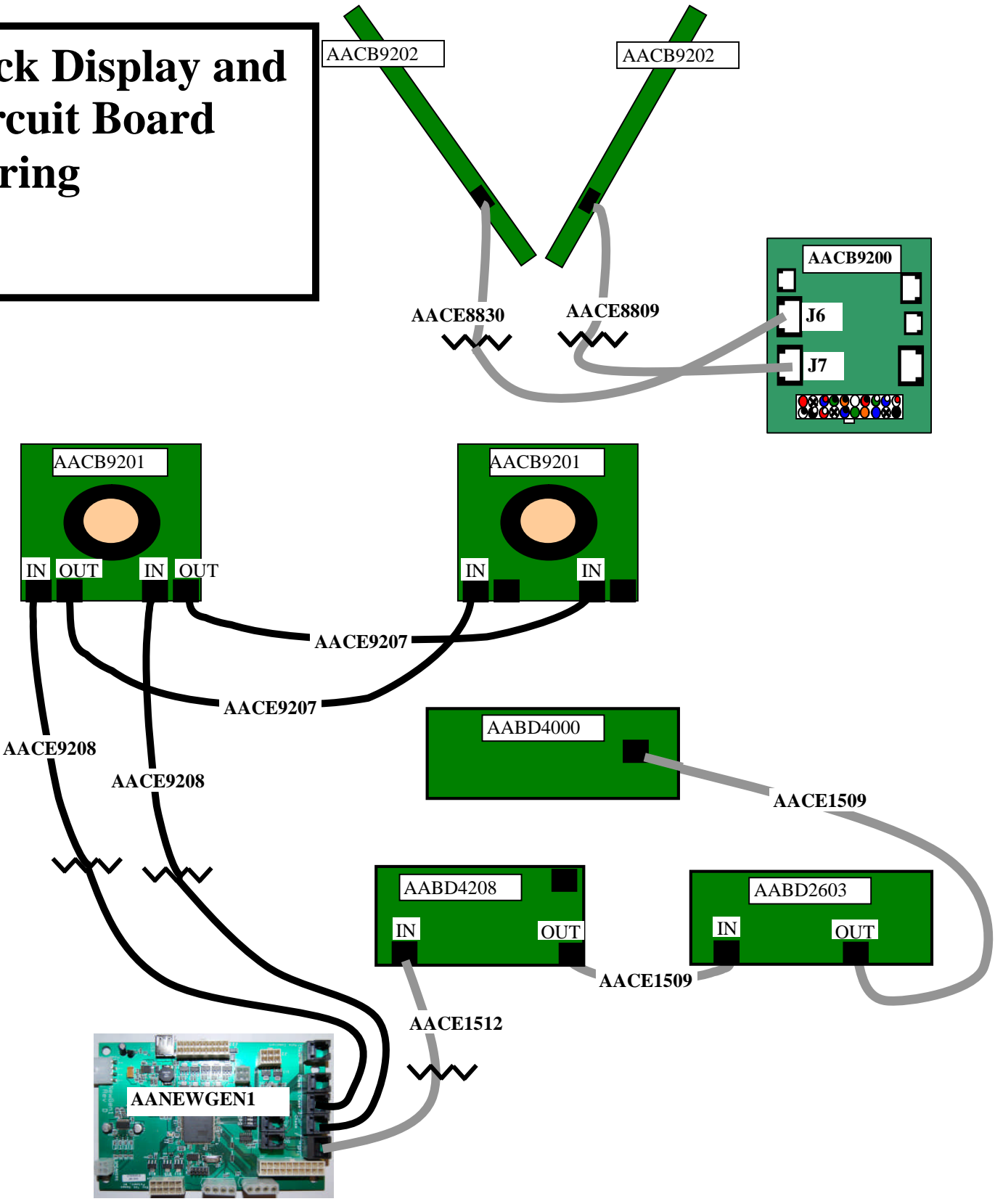

Remember to unplug game before disconnecting or connecting display boards to prevent damage to display boards.

TECHNICAL SUPPORT

Excellent customer service is very important to Bay Tek Games! We know that keeping your games in great operating condition is important to your business. When you need us, we are here to help. You can call us for free technical assistance, and you can count on us to have parts on-hand to support your game. When you do need us, it's important that you know what to expect. We offer options that fit your needs.

Electronics / Circuit Boards - Repair Options

Repair & Return – If you have Circuit Board issues with your Bay Tek game, you can send the board to us and we'll repair it right away. Most items sent to us are repaired and returned to you within two days. This option is your best value as we offer this fast turn-around service at the most reasonable price.

Advance Replacement – If you have Circuit Board issues with your Bay Tek game, but you don't have time to send in your board in for repair, give us a call and ask for an Advance Replacement. We'll send you a replacement board that same day (pending availability). When you get your new board, just repackage the defective board in the same box and send it back to us. We make it easy by including a UPS Return Shipping label for you to put on the box (not available for international shipments). This is your best option when you need to get you game up and running as quickly as possible!

Spare Parts – Take matters into your own hands and purchase new spare Circuit Boards for your Bay Tek games. Many of our games share the same main-board electronics. This means you can buy one set of spare electronics to support many of your Bay Tek games. Spare boards allow you to get your game up and running and provide you a valuable troubleshooting option. Call our technicians to get recommendations for what you should keep on hand for spare parts!

Technical Support:

“You” are the best tool for troubleshooting! Your abilities to understand the game and your skills to repair the game are invaluable to us! If you need help, you know you can call us. It's not easy to diagnose a game remotely by phone, but our technicians do a great job. They'll need your help to perform some troubleshooting steps and convey to them exactly what's happening with your game.

Returns, Credits, & Fees:

NOTICE! ALL ITEMS being sent to Bay Tek Games for repair or return, etc. require prior Return Authorization! Bay Tek Games will provide a Product Return Form with an authorizing Ticket Number for each item to be returned. Please be certain to include this document with all shipments!

Late Fees and Non-Return Fees - Advance Replacement and Warranty Replacement items require the defective items to be returned by Bay Tek games promptly to avoid Late Fees. We would expect items to be returned within 10 working days. Late fees are invoiced monthly. Late fees are non-refundable under any circumstance! Any item not returned within 90 days will be invoiced in full as a replacement part!

Bench Fees - Bench fees will apply for each electronic item returned to Bay Tek Games (this includes unused Advance Replacement items). This charge covers our cost to inspect, evaluate and retest each item. Please note that returned items that do not pass our tests will be charged accordingly as replacement items or advance replacements.

Restocking Fees - Unused items returned for credit will be credited minus a restocking fee. Items must be returned within 30 days of purchase in order to qualify for any credit amount. No shipping charges will be credited.



WARRANTY



Bay Tek Games warrants to the original purchaser that all game components will be free of defects in workmanship and materials for a period of 6 months from the date of purchase. Hint: Register your new game for an extra 3 months on your warranty (Find registration card in the cashbox)

Bay Tek Games will, without charge, repair or replace, at their option, defective component parts upon notification to the parts/service department.

Warranty replacement part(s) will be shipped immediately, via ground service, along with a Product Return Form for the return of defective part(s).

Defective part(s) must be shipped back to Bay Tek Games unless otherwise instructed. Items not returned to Bay Tek Games will be invoiced as replacement parts.

This warranty does not apply in the event of any misuse or abuse to the product, or as a result of any unauthorized repairs or alterations. The warranty does not apply if any serial number decal is altered, defaced, or removed from its original position.

	ATTENTION	
In order to maintain the safety & other compliance certifications of the game, ONLY approved parts may be used. For approved parts, refer to the parts list in this manual.		

Should you need your game serviced, determine the serial number from the decal placed on the front of this manual, or locate it on the back of the game. Then contact our Service Department at: 920.822.3951 or e-mail: service@baytekgames.com

NON-WARRANTY

Should you need your game serviced, determine the serial number on the front page of this manual, or by locating the decal on the back of the game cabinet, and contact our Service Department at: 920.822.3951 or service@baytekgames.com

Options and estimated charges will be provided to you for your approval. Please remember that any items being sent to Bay Tek Games must include prior return authorization from our Parts & Service Department. This approval will include a Product Return Form which is required to be included with any incoming shipments. Repaired part(s) will be shipped back using the same method in which they were received. Repairs are warranted for 30 days from the date of return shipment.

JAM SESSION PARTS LIST

PART #	DESCRIPTION	PART #	DECAL
A5CB8020	Cash Box	AACE9206	Wheel Motor Cable
A5SP1050	Speaker	AACE9207	Speaker Light Cable
A5MI9200	Microphones on Playfield	AACE9208	Guitar Light Cable
AAPB2700	Red Menu Push Buttons	AACE9209	Power Supply Cable
AACB7017	Halogen Lamp Socket	AACE9210	Display Cable
A5SE200	Low Ticket Switch	AACE9211	Tower Lights Cable
A5CR03	12 Volt Counter	AACE9212	Floor Lights Cable
A5LA9200	12 Volt Light	AACE9213	Power Strip Cable
W5TM4003	13/16" Red T-Molding	AACE9214	Aux Board to Sensors Cable
A5LI0001	120 Volt Light	AACE4502	Power Supply Jumper
A5HU1200	Hub For Wheel	AACE8822	Flurorescent Light Power Cable
A5CA4100	Cam	AACE8830	Aux Board to Guitar Chaselight Cable
A5SH4100	Shaft Slide	AACE1509	Display Jumper Cable 2 Per
A5TG9200	Top Glass	AACE1512	Aux Board to Display Cable
A5ME4107	Wheel Motor Mount	AACE1715	Grounding Cable
AAWH9200	Scoring Wheel Assembly	AACB7017	Halogen Lamp Cable
A5GUMO410	Motor Mount Guide	AACE1527	Coin Comparator Cable
A5MO4010	Wheel Motor	AACE1615	Ticket Disp. / Low Tkt. Switch Cable
A5CM-AS-COMP	Coin Mech, Compata	AALIHL110	120 Volt Light Holder Cable
A5FI9010	Inline Filter	AACE4410	Grounding Cable
A5GU5024	Glass Guide	AACE4411	Coin Door Grounding Cable
A5OU1000	Outlet Strip	A5CORD5	AC Computer Cord
A5TD1	Ticket Dispenser	A5ME4104-1	Metal Coin Mech Box
AACE9200	J1 Aux Board Cable	A5ME4111	Metal Ramp Bracket Brace
AACE9201	Main Cable	A5ME4113-1	Metal Coin Mech Door
AACE9202	Ticket / Menu Cable	A5ME4180	Metal Ticket Tray Bracket
AACE9203	Volume Cable	A5ME9200	Metal Right Front Door
AACE9204	Xenon Light Cable	A5ME9201	Metal Coin Box Door
AACE9205	Ticket Tray Jumper Cable	A5ME9202	Metal Front

JAM SESSION PARTS LIST

PART #	DESCRIPTION	PART #	DECAL
A5ME9203	Metal Coin Return Bracket	A5DE9216	Front Cash Box Decal
A5ME9204	Metal Right Light Bracket	A5DE9217	Right Bottom Side Decal (Large Pick)
A5ME9205	Metal Left Light Bracket	A5DE9218	Left Bottom Side Decal (Large Pick)
A5VF9200	Big Guitar Vacuum Form	A5DE9219	Top Right Side Decal
A5VF9201	Center Pick Vacuum Form on Wheel	A5DE9220	Top Left Side Decal
A5DE4103	Scoring Position Decal	A5DE9221	Left Instructions Decal
PART #	DECAL	A5DE9222	Right Instructions Decal
A5DE4110	Rear Coin Shield Acrylic Decal	A5DE9223	Center Wheel Decal (Small Pick)
A5DE9113	Hurry To Shoot Playfield Decal	A5DE9224	Scoring Wheel Decal
A5DE9200	Left Speaker Decal	A5DE9225	Round 1 Ticket Pattern Decals
A5DE9201	Right Speaker Decal	A5DE9226	Round 2 Ticket Pattern Decals
A5DE9202	Big Guitar Decal	A5DE9227	Side Window 1 Decal
A5DE9203	Top Backlit Pick Decal	A5DE9228	Side Window 2 Decal
A5DE9204	Top Left Sm. Marquee Decal	PART #	CIRCUIT BOARD
A5DE9205	Top Center Marquee Decal	AACB1451	Wheel Sensor
A5DE9206	Top Right Small Marquee Decal	AACB1452	Slot Sensor Board
A5DE9207	Left Marquee Small Speaker Decal	AACB1453	Ramp Light Board
A5DE9208	Right Marquee Small Speaker Decal	AACB1455	Level Sensor Board
A5DE9209	Left Ramp Cover Decal	AACB9200	Aux Board
A5DE9210	Right Ramp Cover Decal	AACB9201	Speaker Light Board (X2)
A5DE9211	Right Side Coin Mech Box Decal	AACB9202	Guitar Fret Light Board
A5DE9212	Left Side Coin Mech Box Decal	AABD2603	Tickets Display Board
A5DE9213	Pointer Decal	AABD4208	Bonus Countdown Display Board
A5DE9214	Front Cabinet decal	AABD4000	Jackpot Display Board
A5DE9215	Front Ticket Door Decal	A5PS1001	Power Supply
		AANEWGEN1	New Gen 1 Main Board



SAFETY CERTIFICATIONS

Tested & Certified to FCC & CE, designed to comply with UL-22.