

SERVICE MANUAL



Ver 1.1



ISSUE DATE: June. 27, 2017



- ▶ Please read the manual carefully and keep it in mind before using this machine.
- ▶ Put this manual within touch of your reference in anytime.

PRECAUTIONS FOR USE

The following safety precautions are given throughout this manual. They must be strictly followed to protect those who install, use or maintain this product as well as to protect players, visitors and property.

For safety reasons.

- The following suggestions should be adhered to:



Disregarding could result in serious injury.



Disregarding could result in injury or product damage.

- The following graphic suggestions describe the types of precautions to be followed.



Indicates a care should be taken.



Forbidden.



Indicates a matter which must be performed.

- **Precautions to be followed:**

Certain procedures require a qualified in-shop maintenance person or industry specialist. For such instructions, a qualified person must take care of the jobs.

- Otherwise an electric shock, machine trouble, or a serious accident may result.
- Replacing the machine parts, inspecting and maintaining the machines, and troubleshooting must be assigned only to a qualified in-shop maintenance person or industry specialist. This booklet gives instructions that hazardous jobs in particular must be handled by an industry specialist. Qualified in-shop maintenance person and industry specialist are defined as follows.

Qualified in-shop maintenance person

- A service staff shall have experience in operations of game machines. The staff shall be responsible for assembly, installation, inspection and maintenance of the machine.

Industry specialist

- An industry specialist must be engaged in designing, manufacturing, inspecting and servicing amusement machines. He or she must have an education in electrical, electronic and mechanical engineering, and routinely maintain and repair amusement machines.

PRECAUTIONS FOR USE

WARNING

Be sure to consult an industry specialist when setting up, moving or transporting this product.

- This product should not be set up, moved or transported by any one other than an industry specialist.
- When installing this product, set the 4 leg levelers evenly on the floor and make sure that the product is installed stably in a horizontal position. Unstable installation may result in injury or accident.
- When installing this product, do not apply undue force on movable parts. Otherwise, injury and accident may result, or the product may be damaged.

The machine for indoor usage only does not install outside.



Do not set the game machine up near emergency exits.



Protect the game machine from:

- Rain or moisture.
- Direct sunlight.
- Direct heat from air-conditioning and heating equipment, etc..
- Hazardous flammable substances.
- Otherwise an accident or malfunction may result.



Do not place containers holding chemicals or water on or near the game machine.



Do not place objects near the ventilating holes.



Do not bend the power cord by force or place heavy objects on it.



Never plug or unplug the power cord with wet hands.



Never unplug the game machine by pulling the power cord.



CAUTION

Be sure to use indoor wiring within the specified voltage requirements. For extension cord, use the specified rating or more.

Be sure to use the attached power cord.

Never plug more than one cord at a time into the electrical receptacle.



Do not lay the power cord where people walk through.



Be sure to ground this product.



Do not exert excessive force when moving the machine.



For proper ventilation, keep the game machine 100mm(4") away from the walls.

Do not alter the system related dipswitch settings.

PRECAUTIONS FOR USE

WARNING

If there is any abnormality such as smoke, bad smell or abnormal noise being emitted from the machine, immediately turn OFF the main power switch and unplug the power cord from the receptacle to stop operating it. 

- Using the machine in abnormal conditions could result in fire or accidents.

In case of abnormality

1. Turn OFF the main power switch.
2. Unplug the power cord from the receptacle.
3. Contact your nearest dealer.

Do not leave the power cord plugged in improperly or covered with dust. 

- Doing so could result the power cord periodically.

CAUTION

Do not use this product anywhere other than industrial areas. 

- Using in a residential area or an area next to a residential area could affect signal reception of radios, television sets, telephones, etc..

- Do not give shock the surface of glass products.

- Please do not play this game if
 - When you do drinking;
 - When your physical condition is not normal;
 - When you are in pregnancy;
 - When you have on a pulse controller;
 - When you have recently experienced a cramp or fainting away while watching TV.

- Avoid excessive force/shock while playing/moving the game.

- While do games, pay attention to surrounding.

Do not plug or unplug the power cord with wet hands. 

In handling the power cord, follow the instructions below. 

- | | |
|---|--|
| • Do not damage the power cord. | • Do not modify the power cord. |
| • Do not bend the power cord excessively. | • Do not twist the power cord. |
| • Do not heat the power cord. | • Do not pull the power cord. |
| • Do not bind the power cord. | • Do not stand on the power cord. |
| • Do not sandwich the power cord. | • Do not drive a nail into the power cord. |

If the power cord or power plug becomes damaged, stop using the machine immediately and ask your nearest dealer to replace the parts.

- * **Electromagnetic wave may cause unexpected noise from speaker.**

PRECAUTIONS FOR USE

⚠ WARNING

Be sure to turn OFF the main power switch and unplug the power cord from the receptacle before inspecting or cleaning the machine.



When replacing parts, be sure to use parts of the correct specifications. Never use parts other than the specified ones.



Opening inside the machine shall be done by machine specialist only as high electric current is being sent inside. For game machine with monitor, a care should be taken while opening its back door. If not, a damage to the inside parts or the monitor may occur.



If the sub power switch of the service panel is turned OFF without turning OFF the main power switch of the power supply unit, some parts in the units remain live. When opening the back door, be sure to turn OFF the main power switch and unplug the power cord from the receptacle.



Strictly refrain from disassembly and repair of parts which are not indicated in this manual, as well as settings and remodeling.



To clean the game machine, wipe it with a soft cloth dampened in a neutral detergent.

- Using thinner or other organic solvent or alcohol may decompose the material.
- Electrical shock or equipment failure could be caused by water entering the inside of the machine.

⚠ CAUTION

Components in the game are sensitive to vibrations and impact. Care should be used when moving and transporting the game machine.



Be sure not to let the machine tip over.

Before moving the machine, be sure to turn OFF the main power switch, unplug the power cord from the receptacle and remove the power cord from the machine.



Before moving take the machine, off the levelers and move it on the casters.

Avoid excessive force while moving the machine.

.....

PRECAUTIONS IN HANDLING

- When setting up, inspecting, maintaining, moving or transporting this product, follow the procedures and instructions set forth in this manual and perform such work safely.
- Do not set up, handle, inspect, maintain, move or transport this product under conditions equivalent to the condition of "WARNING" or "CAUTION" specified in this manual.
- If a new owner is to have this product as a result of transfer, etc., be sure to give this manual to the new owner.

PRÉCAUTION D'EMPLOI

Les consignes de sécurité suivantes sont données dans ce manuel. Elles doivent être strictement suivies pour protéger ceux qui les installent. Utiliser ou entretenir ce produit pour la sécurité des utilisateurs, des visiteurs et des biens.

Pour des raisons de sécurité.

- **Les suggestions suivantes doivent être respectées:**

ATTENTION

Le non-respect peut entraîner des blessures graves.

PRUDENCE

Le non-respect peut entraîner des blessures ou des dommages au produit.

- **Les suggestions graphiques suivantes décrivent les types de précautions à prendre.**



Indique qu'attention est requise.



Interdit.



Indique que quelque chose doit être effectuée.

- **Les précautions à prendre :**

Certaines procédures exigent une personne de maintenance qualifiée en atelier ou un spécialiste de l'industrie. Pour ces instructions, une personne qualifiée doit prendre soin des travaux.

- Sinon, un choc électrique, un dysfonctionnement de la machine, ou un accident grave peut en résulter.
- Remplacement des pièces de machines, l'inspection et la maintenance des machines, et le dépannage doit être attribué qu'à une personne de maintenance qualifiée en atelier ou spécialiste de l'industrie. Cette brochure donne des instructions que les emplois dangereux, en particulier, doivent être traités par un spécialiste de l'industrie. La personne de maintenance qualifiée en atelier et le spécialiste de l'industrie sont définis comme suit.

La personne de maintenance qualifiée en atelier

- Un personnel de service doit avoir de l'expérience dans les opérations de machines de jeux. Le personnel est responsable pour l'assemblage, l'installation, l'inspection et l'entretien de la machine.

Le spécialiste de l'industrie

- Un spécialiste de l'industrie doit être engagé dans la conception, la fabrication, l'inspection et l'entretien des appareils d'amusement.
Il ou elle doit avoir une formation en génie électrique, électronique et mécanique, et de maintenir régulièrement et de réparer les appareils d'amusement.

PRÉCAUTION D'EMPLOI

ATTENTION

Si il y a une anomalie comme fumée, mauvaise odeur ou bruit anormal émis par la machine,  couper immédiatement l'interrupteur principal et débranchez le câble d'alimentation de la prise pour arrêter son fonctionnement.

- L'utilisation de l'appareil dans des conditions anormales peut provoquer un incendie ou un accident.

En cas d'anomalie

1. Mettez l'interrupteur principal sur ARRÊT.
2. Débranchez le câble d'alimentation de la prise.
3. Contactez votre revendeur le plus proche.

Ne pas brancher le câble d'alimentation incorrectement ou le laisser être recouvert de poussière. 

Cela pourrait nuire le câble d'alimentation.

PRUDENCE

Ne pas utiliser ce produit ailleurs que dans les zones industrielles. 

- L'utiliser dans une zone résidentielle ou d'une zone à côté d'un quartier résidentiel pourrait nuire à la réception des radios, téléviseurs, téléphones, etc.
- Ne donnez pas de choc à la surface d'un produit en verre.

- S'il vous plaît ne pas jouer à ce jeu.
 - Quand vous buvez;
 - Lorsque votre condition physique n'est pas normale;
 - Lorsque vous êtes dans une période de grossesse;
 - Lorsque vous avez un contrôleur d'impulsion;
 - Lorsque vous avez récemment subi une crampe ou évanouissement en regardant la télévision.
- Évitez une force excessive / un choc pendant la lecture / de déplacer le jeu.
- Quand vous jouez les jeux, faite attention aux alentours.

Ne pas brancher ou débrancher le câble d'alimentation avec les mains mouillées. 

Dans la manipulation du câble d'alimentation, suivez les instructions ci-dessous. 

- | | |
|--|---|
| • Ne pas endommager le câble d'alimentation. | • Ne pas modifier le câble d'alimentation. |
| • Ne pas plier le câble d'alimentation de manière excessive. | • Ne tordez pas le câble d'alimentation. |
| • Ne pas chauffer le câble d'alimentation. | • Ne tirez pas sur le câble d'alimentation. |
| • Ne pas lier le câble d'alimentation. | • Ne montez pas sur le câble d'alimentation. |
| • Ne pas prendre en sandwich le câble d'alimentation. | • Ne pas mettre un clou dans le câble d'alimentation. |

Si la fiche du câble d'alimentation ou est endommagé, cessez immédiatement d'utiliser la machine et demandez à votre revendeur le plus proche de remplacer les pièces.

PRÉCAUTION D'EMPLOI

⚠ ATTENTION

Assurez-vous de consulter un spécialiste de l'industrie lors de la mise en place, du déplacement ou le transport de ce produit.

- Ce produit ne doit pas être mis en place, déplacé ou transporté par une quelconque autre qu'un spécialiste de l'industrie.
- Lors de l'installation de ce produit, installez 4 niveleurs de pieds uniformément sur le sol et assurez-vous que le produit est installé de façon stable dans une position horizontale. Une installation instable peut entraîner des blessures ou un accident.
- Lors de l'installation de ce produit, ne pas appliquer une force excessive sur les pièces mobiles. Sinon, des blessures et des accidents peuvent y résulter, ou le produit peut être endommagé.

La machine pour une utilisation en intérieur uniquement, ne pas installer à l'extérieur.



N'installez pas la machine de jeu près des issues de secours.



Protéger la machine de jeu de:



- L'humidité ou la pluie.
- La lumière directe du soleil.
- La chaleur directe de la climatisation et du chauffage, etc...
- Des substances inflammables dangereuses.
- Sinon, un accident ou un dysfonctionnement.

Ne pas placer les récipients contenant des produits chimiques ou de l'eau sur ou près de la machine de jeu.



Ne placez pas d'objets à proximité des orifices de ventilation.



Ne pas plier le cordon d'alimentation par la force ou de placer des objets lourds au-dessus.



Ne jamais brancher ou débrancher le cordon d'alimentation avec les mains mouillées.



Ne jamais débrancher la machine de jeu en tirant le câble d'alimentation.



⚠ PRUDENCE

Veillez à utiliser le câblage intérieur selon les exigences de tension spécifiées. Pour une rallonge, utilisez la notation spécifiée ou plus.

Veillez à utiliser le cordon d'alimentation fourni.

Ne jamais brancher plus d'un cordon à la fois dans la prise électrique.



Ne pas poser le cordon d'alimentation où les gens marchent à travers.



Soyez sûr de mettre à la terre ce produit.



Ne pas exercer une force excessive lors du déplacement de la machine.





Pour une ventilation correcte, garder la machine de jeu 100mm (4 ") loin des murs.

Ne pas modifier les réglages des commutateurs DIP liées au système.

PRÉCAUTION D'EMPLOI

ATTENTION

Veillez à éteindre l'interrupteur d'alimentation principale et débranchez le cordon d'alimentation de la prise avant d'inspecter ou de nettoyer la machine. 

Lors du remplacement des pièces, veillez à utiliser une partie des spécifications correctes. Ne jamais utiliser de pièces autres que celles spécifiées. 

L'ouverture à l'intérieur de la machine doit être effectuée par le spécialiste de la machine seulement, comme le courant électrique élevé est transmis à l'intérieur. Pour la machine de jeu avec le moniteur, un soin doit être pris lors de l'ouverture de sa porte arrière. Si non, une détérioration des pièces à l'intérieur ou à l'écran peut se produire. 

Si l'interrupteur secondaire du panneau de service est éteint sans éteindre le commutateur d'alimentation principale de l'unité d'alimentation, certaines parties dans les unités restent sous tension. Lors de l'ouverture de la porte arrière, veillez à éteindre l'interrupteur d'alimentation principale et débranchez le cordon d'alimentation de la prise. 

Il est strictement conseillé de s'abstenir de démonter et de réparer des pièces qui ne sont pas indiqués dans ce manuel, ainsi que les paramètres et le remodelage. 

Pour nettoyer la machine de jeu, l'essuyer avec un chiffon doux imbibé avec un détergent neutre.

- L'utilisation plus mince d'un autre solvant organique ou de l'alcool peut décomposer le matériel.
- Un choc électrique ou une défaillance de l'équipement pourraient être causés par la pénétration de l'eau à l'intérieur de la machine.

PRUDENCE

Les composants de la machine de jeu sont sensibles aux vibrations et aux chocs. Il faut faire attention lors du déplacement et le transport de la machine de jeu. 

Veillez à ne pas laisser la machine se renverser.

Avant de déplacer la machine, veillez à éteindre l'interrupteur d'alimentation principale, débranchez le cordon d'alimentation de la prise et débranchez le cordon d'alimentation de la machine. 

Avant de déplacer la machine, la mettre hors des niveleurs et le déplacer sur les roulettes.

Éviter une force excessive lors du déplacement de la machine.

.....

PRÉCAUTIONS LORS DU MANIEMENT

- Lors de la mise en place, l'inspection, l'entretien, déplacement ou le transport de ce produit, suivez les procédures et les instructions énoncées dans ce manuel et effectuer ce travail en toute sécurité.
- Ne pas mettre en place, manipuler, inspecter, entretenir, déplacer ou transporter ce produit dans des conditions équivalentes à l'état de "ATTENTION" ou "PRUDENCE" spécifiée dans ce manuel.
- Si un nouveau propriétaire obtient ce produit à la suite d'un transfert, etc., soyez sûr de donner ce manuel au nouveau propriétaire.

CONTENTS

1. SPECIFICATION AND DIMENSIONP02	5-12. COUNTER ERRORP45
1-1. DIMENSIONP02	5-13. SOUND ERRORP46
1-2. SPECIFICATIONP02	5-14. 2813B 16EA, 21EA WHEN NOT LITP47
1-3. NAME OF PARTSP03	5-15. 2813B 30EA, 21EA WHEN NOT LITP48
1-4. STICKER LOCATIONP04	5-16. 2813B FLEX or SIDE LIGHT WHEN NOT LITP49
1-5. COMPONENTSP05	6. EXPLODED VIEWP50
2. INSTALLATIONP06	6-1. MAIN CABINET PARTP50
2-1. INSTALLATION SPACEP06	6-2. TOP BILLBOARD PARTP51
2-2. HOW TO INSTALLP07	6-3. BILLBOARD MAIN PARTP52
3. GAME CHARACTERISTICSP09	6-4. BACK BOARD PARTP53
4. SETUP SETTINGP10	6-5. CABINET UPPER DISPLAY PARTP54
4-1. MACHINE SETUPP10	6-6. BUTTON PLATE PARTP55
4-2. SETUP MODEP12	6-7. COIN CONVEYOR PARTP56
4-3. CLEAR MODEP18	6-8. CARD CONVEYOR PARTP57
4-4. TEST MODEP21	6-9. CARD DISPENSER PARTP58
4-5. ERROR CODEP24	6-10. FRONT UPPER DOOR PARTP59
* THE CHECKING METHOD FOR WRONGLY WORKING SENSORP25	6-11. SETUP PANEL PARTP60
* CHECKING METHOD OF DM JELLY'S TOKEN SENSOR PCBP26	6-12. TICKET DOOR PARTP60
5. TROUBLESHOOTINGP28	6-13. SMPS PARTP61
5-1. CREDIT FND PCB ERRORP28	6-14. FRONT LOWER DOOR PARTP61
5-2. 1P TICKET FND PCB ERRORP29	6-15. REAR LIGHTING-L PARTP62
5-3. 2P TICKET FND PCB ERRORP30	6-16. GAME PLATE MIDDLE DISPLAY PARTP62
5-4. JACKPOT FND PCB ERRORP31	6-17. MAIN BOARD PARTP63
5-5. COIN SELECTOR ERRORP32	6-18. BACK BOARD REAR PARTP63
5-6. MAIN GAME BELT MOTOR ERRORP33	6-19. GAME PLATE MIDDLE PCB PARTP64
5-7. CARD BELT DROP MOTOR ERRORP35	6-20. CABINET UPPER BAR LED PARTP64
5-8. BELT SCAN SENSOR ERRORP37	6-21. TOKEN DROP HOPPER PARTP65
5-9. TOKEN DROP HOPPER ERRORP39	6-22. CARD OUT CHUTE PARTP66
5-10. CARD DISPENSER ERRORP42	6-23. COIN BOX COVER PARTP66
5-11. TICKET DISPENSER ERRORP44	6-24. GAME BOTTOM FLEXIBLE LED PCB PARTP67
		7. BLOCK DIAGRAMP68

1. SPECIFICATION AND DIMENSION

1-1. DIMENSION

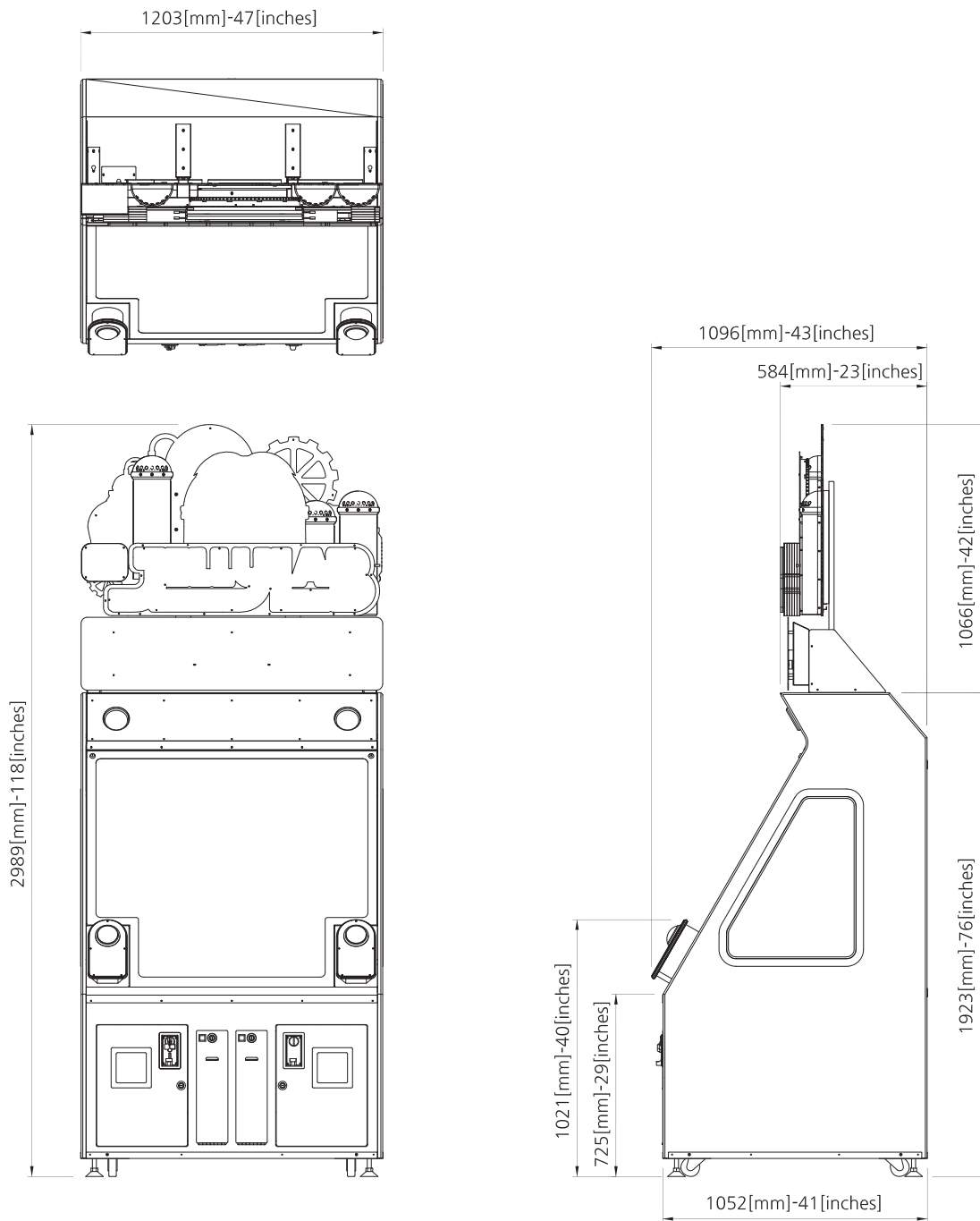

1-2. SPECIFICATION

DIMENSION (W x D x H)	1203 x 1096 x 2989 (mm)	
PACKING DIMENSION (W x D x H)	1150 x 1700 x 2100 (mm)	
WEIGHT (kg)	320 kg [WEIGHT INCLUDING : 355 kg] PACKAGING]	
VOLTAGE	AC 120V	AC 230V
FREQUENCY RANGE	60Hz	50,60Hz
CONSUMPTION	360 W	360 W
CERTIFICATION	-	

1-3. NAME OF PARTS

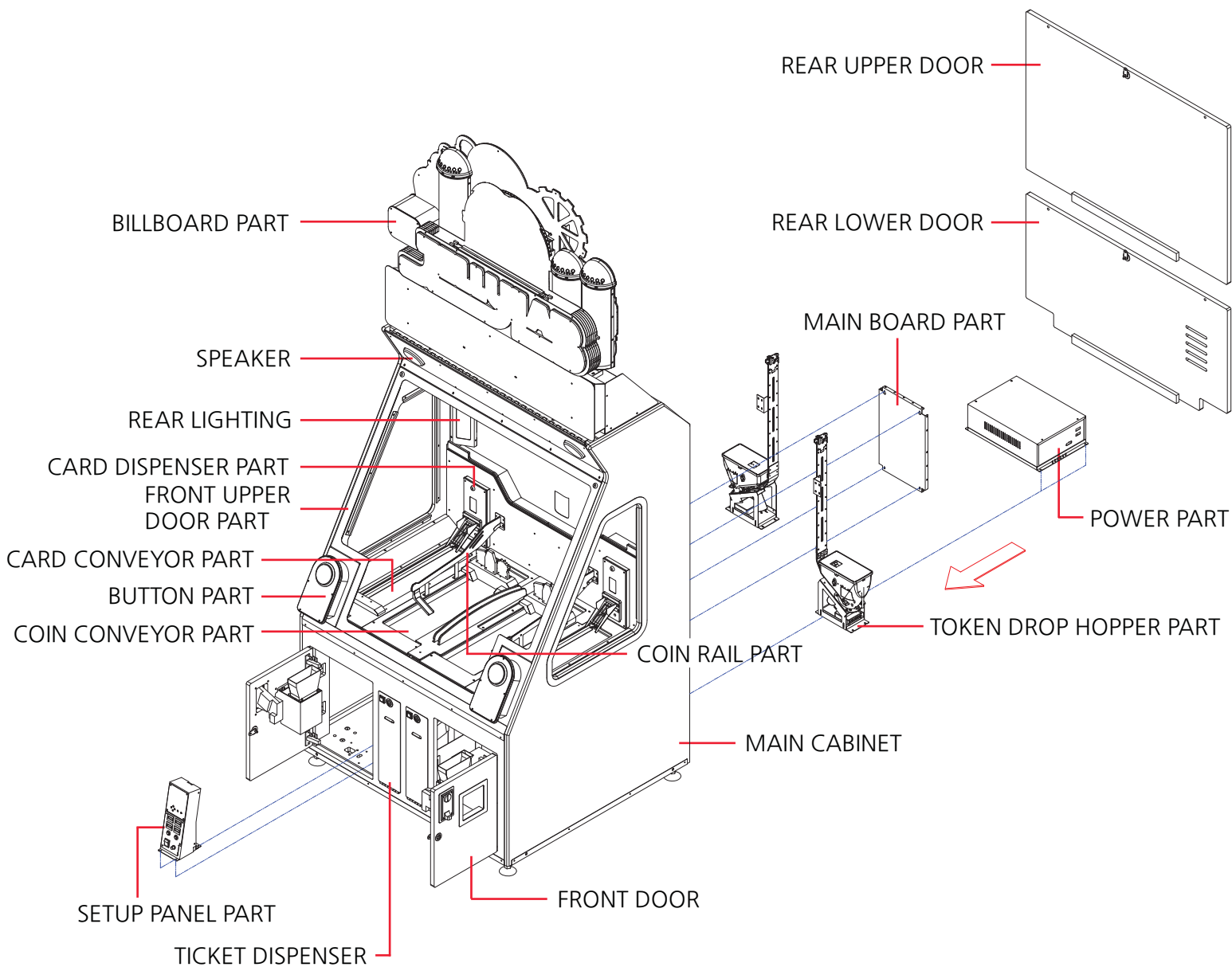

1-4. STICKER LOCATION

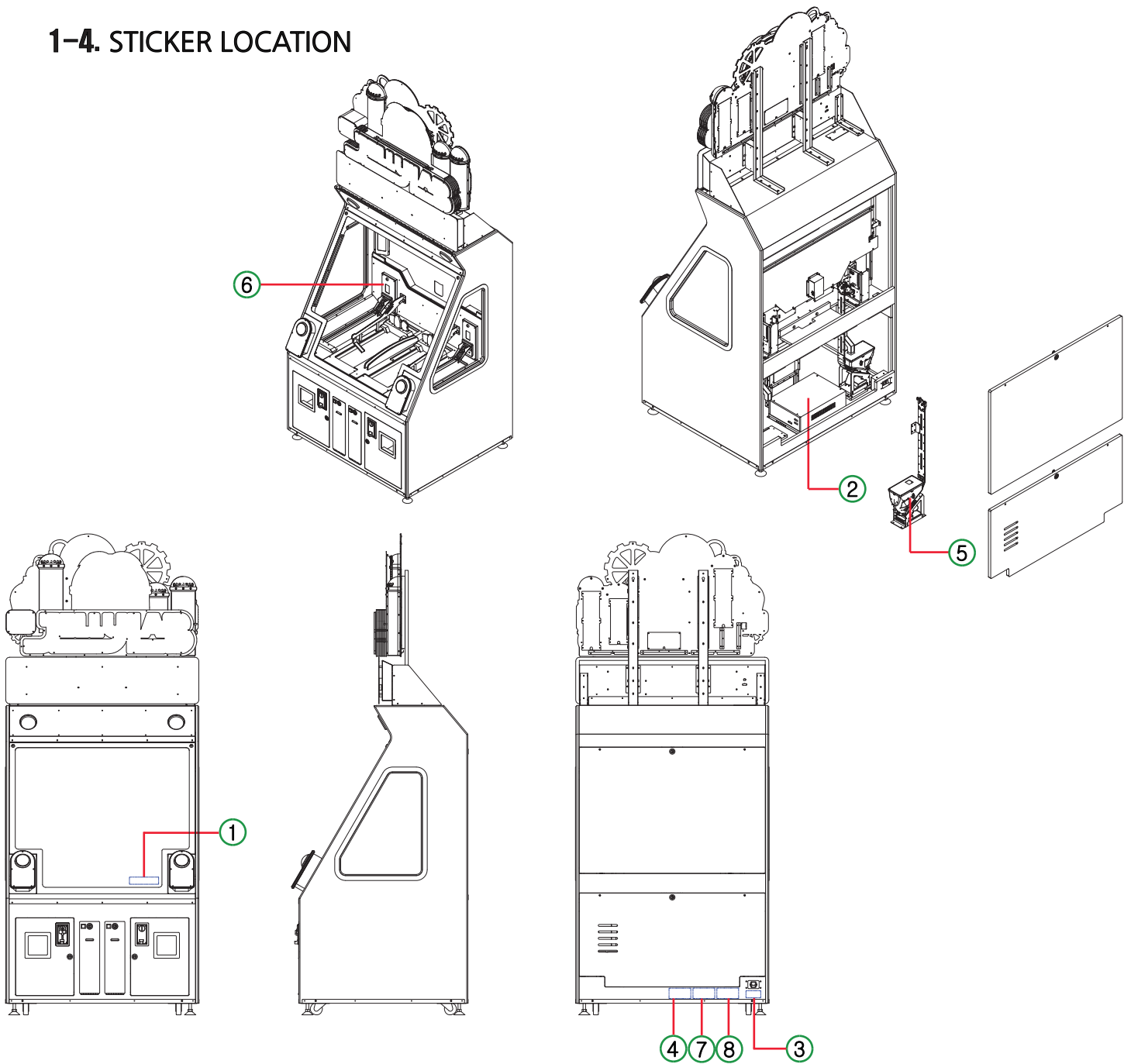

1

	Do not push or hit this. It would be damaged.
	Ne pas le pousser ou frapper. Elle serait endommagée.

2

WARNING/ATTENTION	
	Except service personnel, please never open the product as there is a risk of electric shock.
	Il y a un risque d'électrocution, n'ouvrez pas le produit excepté le responsable, s'il vous plaît.

3

CAUTION/PRUDENCE	
For continuous protection against risk of fire, replace only with the same type 10A-250V fuse	
Pour une protection continue contre les risques d'incendie, remplacer un fusible avec seulement le même type 10A-250V	

4

WARNING ROCKING, SHAKING OR TIPPING MAY CAUSE INJURY OR DEATH! This unit must be fastened securely to the wall, floor or adjacent object in compliance with the installation instructions.
ATTENTION AGITER, SECOUER OU BASCULER PEUT CAUSER DES BLESSURES OU ENTRAÎNER LA MORT! Cette unité doit être fixée au mur, au plancher ou à un objet à proximité conformément aux instructions d'installation.

5

NOTICE	
Please be sure to use the coins supplied by Andamiro. Otherwise, it will cause troubles to operation of hopper.	
To clear out error 06 (ER06), tap the coin hopper by hand, then, push the reset button.	

6

NOTICE	
Before loading new cards, shuffle all cards properly.	



7



8

Product Name: GAME MACHINE Model No.: DM JELLY LAB Rating: 120V~, 60Hz, 210W Web site: http://www.andamiro.com	 Intertek 5001493
ANDAMIRO MADE IN KOREA	Intertek 5001493 Intertek is a member of the Intertek Group of companies. Intertek is a member of the Intertek Group of companies. Intertek is a member of the Intertek Group of companies.
Serial Number	

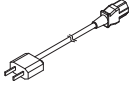
1-5. COMPONENTS

NO.	PART NAME	SPEC.		QTY
1	AC POWER CORD	-		1
2	KEY	6001, 7001		EACH 2
3	BOLT	4x8		13
4	BOLT	4x10		10
5	BOLT	4x25		3
6	BOLT	6x20		22
7	BOLT	6x30		19
8	WRENCH	3mm		EACH 1
9	STICKET REMOVER	-		1
10	COIN CHECK SENSOR BKT	-		1
11	CARD HEAVY PUSH BKT	-		2
12	CABINET TOP HARNESS COVER BKT	-		1
13	TOKEN	-		130
14	MANUAL	-		1
15	TROUBLE SHOOTING MANUAL	-		1
16	RETAIL COIL	-		2

2. INSTALLATION

2-1. INSTALLATION SPACE

- Need to have installation place.
Maintenance Zone & Play zone should have at least 3000mm x 2700mm each.

IMPORTANT

- Once you set up the machine with required game-play area, when installing this product, set the 4 leg levelers evenly on the floor and make sure that the product is installed stably in a horizontal position. Otherwise the set winning percentage can be twisted.

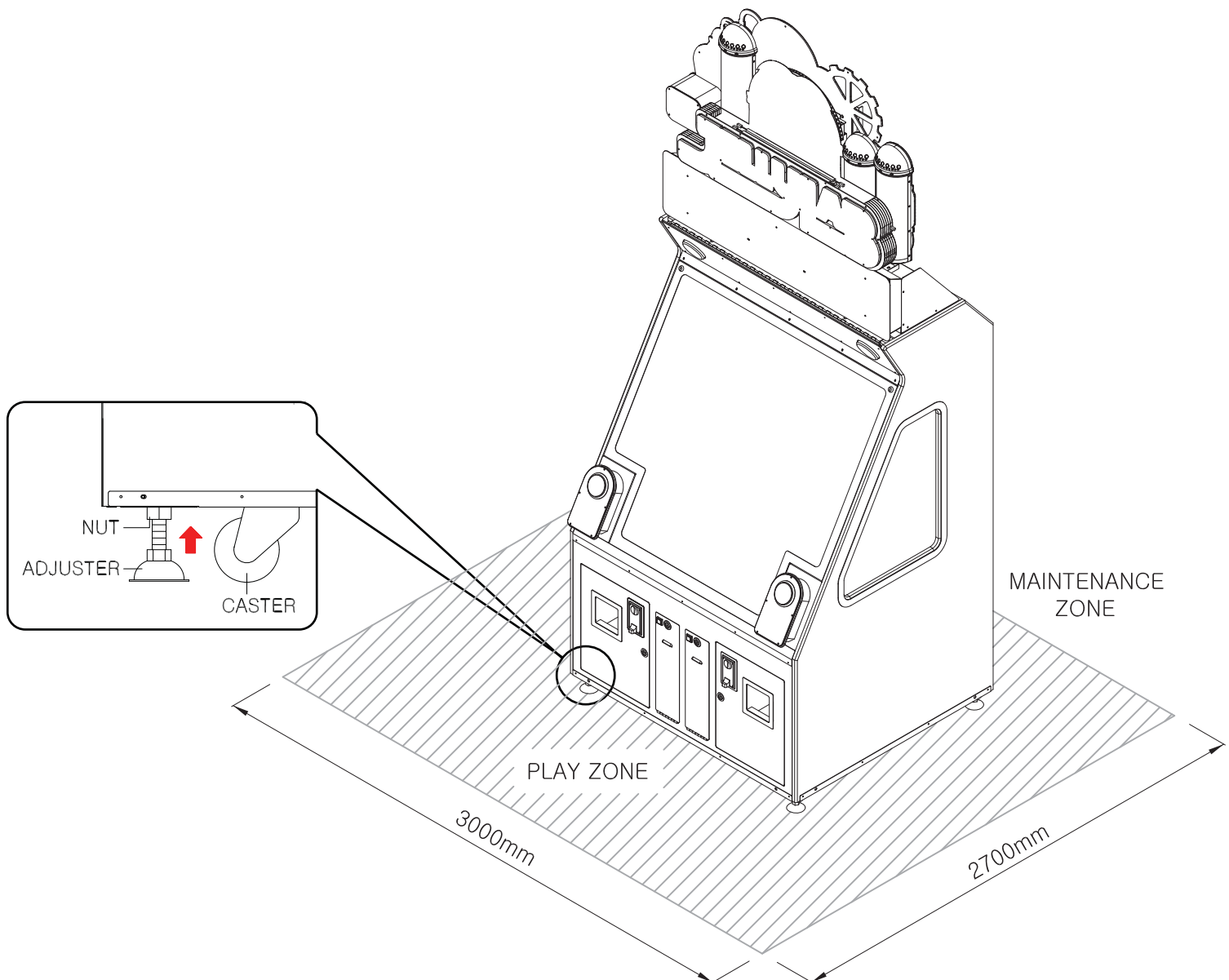

2-2. HOW TO INSTALL

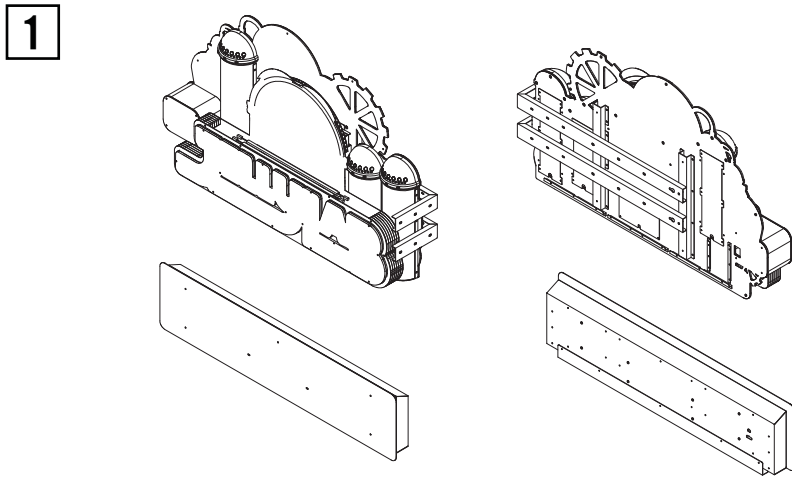

- Billboard part is separately packed in TOP BILLBOARD and BILLBOARD MAIN ASS'Y.

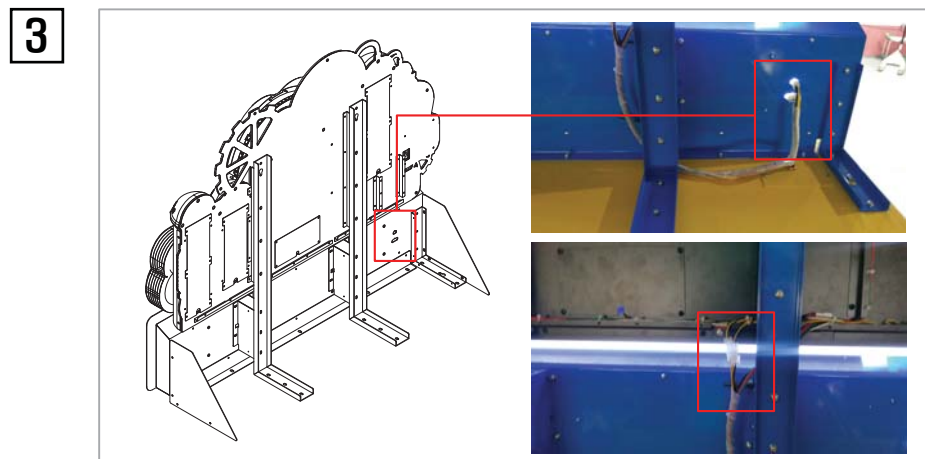
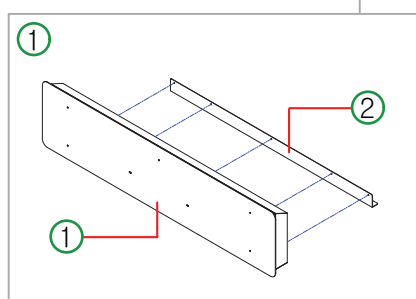
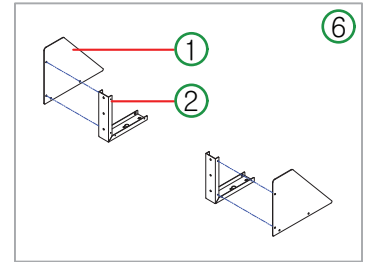
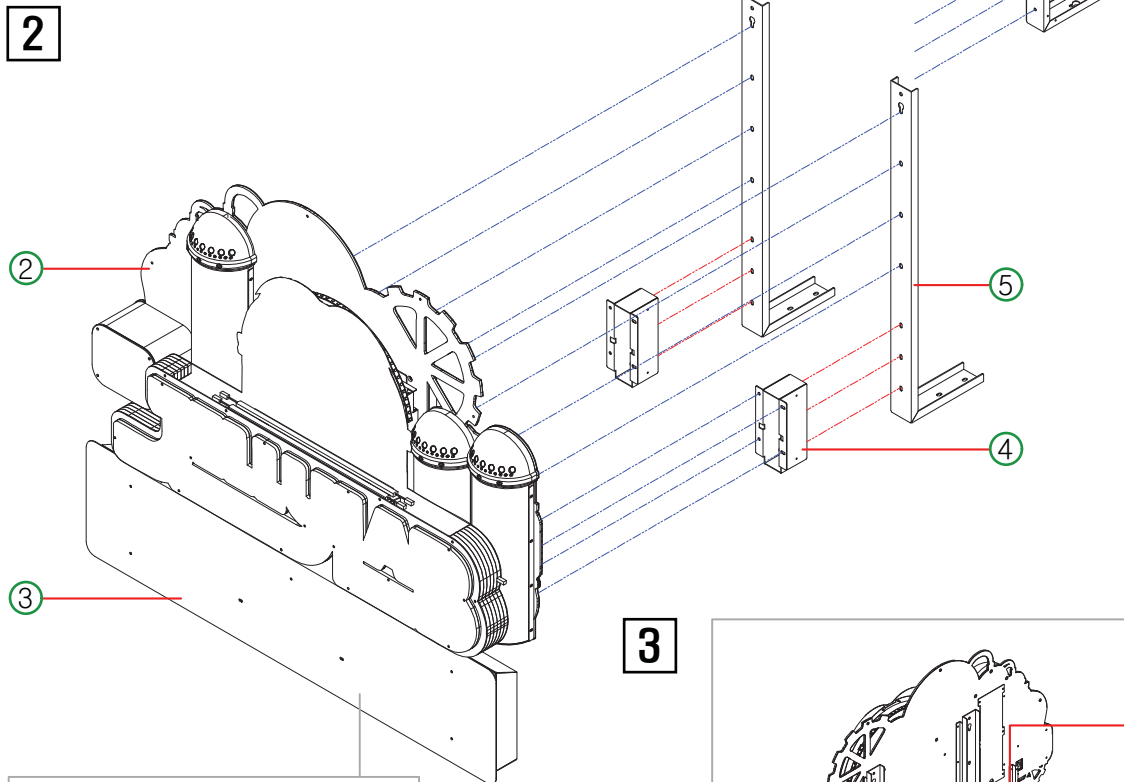

- Combine **2** BILLBOARD MAIN REAR LOWER SUPPORT BKT to **1** BILLBOARD MAIN ASS'Y as picture.
[M4 bolt, 5pcs]

- Attach **4** BILLBOARD MAIN REAR MID SUPPORT BKT[2pcs]_[M6 bolt, 4pcs], **5** BILLBOARD ASS'Y REAR FIX BKT[2pcs]_[M6 bolt, 4pcs] to **2** TOP BILLBOARD+ **3** BILLBOARD MAIN ASS'Y.

- Finally, complete the assemble as **3** picture by using [M6 bolt, 6pcs] after combine **6** BILLBOARD SIDE ACRYL-L,R ASS'Y.

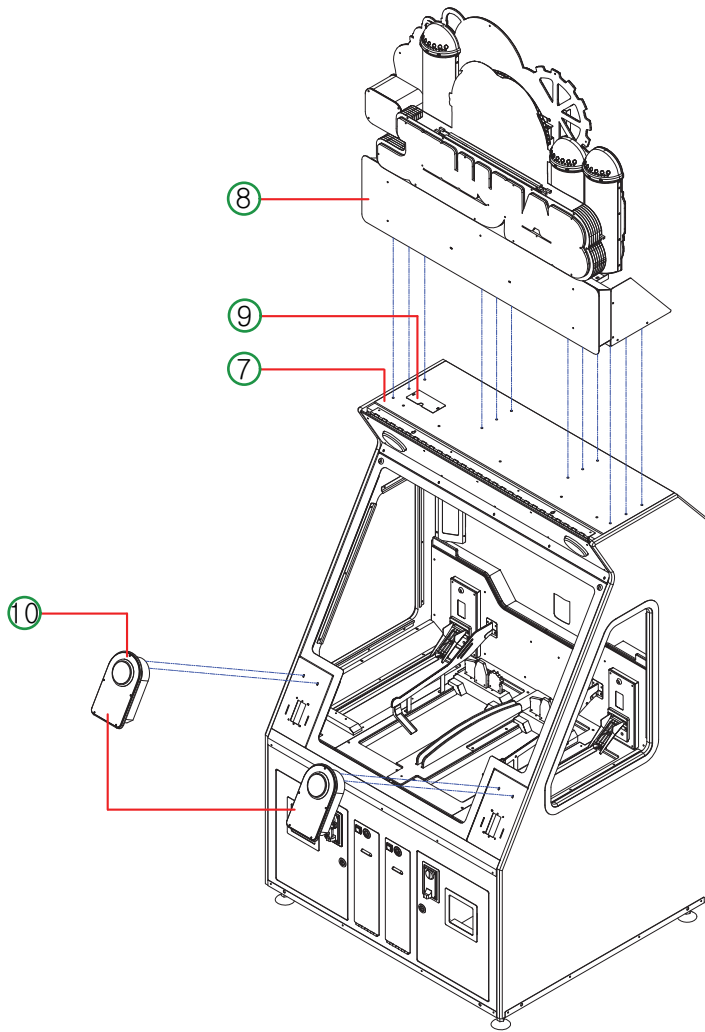
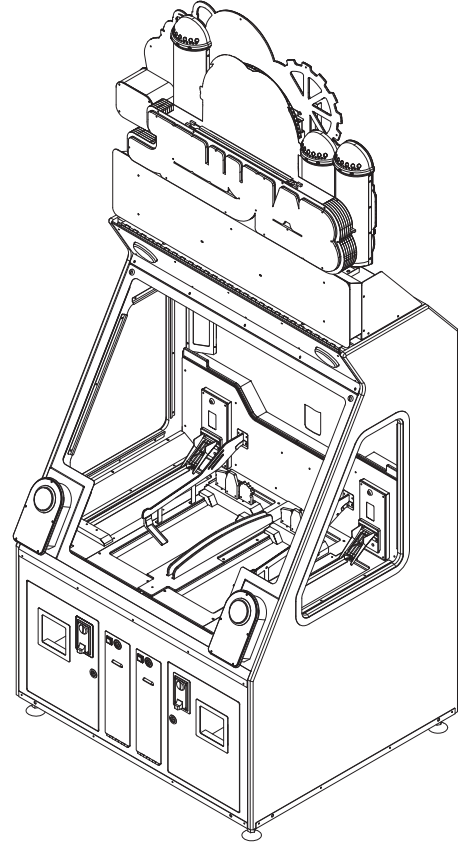
4**5**

- Combine ⑧ BILLBOARD ASS'Y + ⑨ CABINET TOP HARNESS COVER BKT to ⑦ MAIN CABINET. [M6 bolt, 12pcs]
- Assembly after hook MAIN CABINET by using ⑩ BUTTON PLATE ASS'Y[2pcs]_[M4 bolt, 2pcs].

3. GAME CHARACTERISTICS

3-1. JELLY LAB, IS 1 IN A MINION!

- : Gru and his Minions are back with a dazzling new game that will dazzle new game fans that will bring Despicable Me Fans of all ages into your location and the collectible card feature will keep them coming back!

COLLECT ALL SEVEN CARDS FOR SUPER BONUS



**BONUS
CARD**



4. SETUP SETTINGS

4-1. MACHINE SETUP

1. HOW TO ENTER SETUP MENU

- 1 There is "Control panel" inside cabinet. User may set any setting using following.

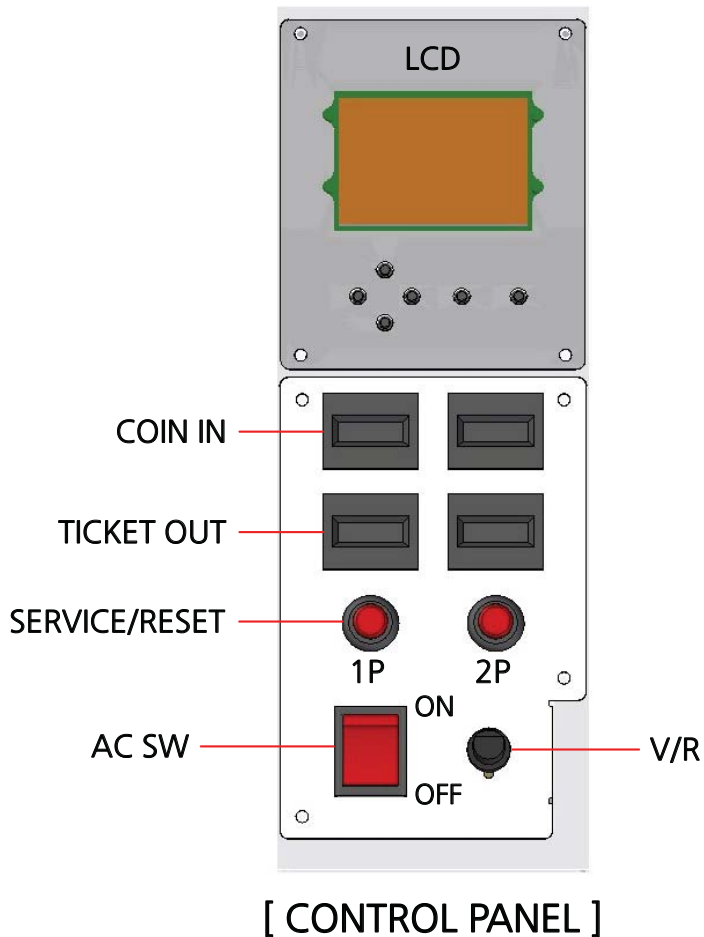

2. SETUP BUTTON LAYOUT

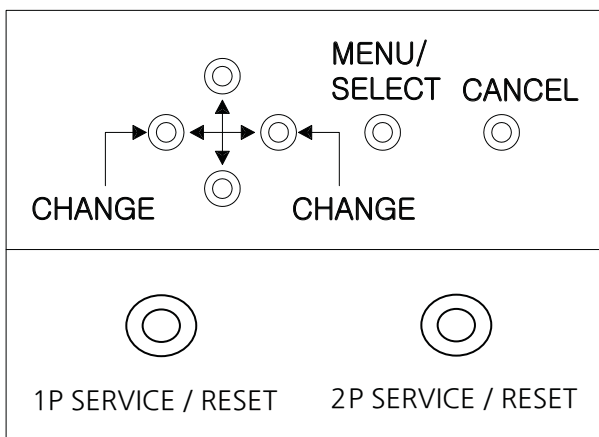

- 1) [↑ ↓] Up/Down Key : Menu Up/Down move
- 2) [← →] Left/Right Key : Change Setting value
- 3) MENU/SELECT key : Set up Menu mode, Select perform
- 4) CANCEL key : Exit

Normally Service In,
On ERROR, use to cancel ERROR.
* 1Credit per 1 service in

[OPERATION MENU]

PRESS MENU BUTTON. [MENU/SELECT : ENTER SETUP MODE]	
PROGRAM SETTINGS	SETUP MODE FOR OPERATION OPTIONS
CLEAR MODE	CLEAR MODE FOR DATA
BOOKKEEPING	BOOKKEEPING DATA
FACTORY SETTING	SET GAME TO FACTORY-SET VALUES
TEST MODE	TEST MODE
EXIT	EXIT OPERATION OPTIONS

4-2. SETUP MODE

LCD DISPLAY	DESCRIPTION	RANGE	DEFAULT
PLAYS / COIN * DIP	SET PLAYS (CREDITS) QTY PER COIN. IF USING COIN OR SWIPE CARD CONTINUOUSLY WITHOUT PLAY, DIFFERENT PLAY (CREDITS) QTY ARE PAID ACCORDING TO THE CONTINUOUS SWIPING NUMBERS.	-> SUB MENU (REFER TO THE TABLE #1 BELOW)	(REFER TO THE TABLE #1 BELOW)
CONTINUE PLAY	FUNCTION THAT CAN BLOCK ADDING CREDIT DURING GAME PLAY. "OFF": AFTER GAME STARTS, BLOCK ADDING CREDIT UNTIL PLAY QTY IS 0. "ON": ALWAYS POSSIBLE TO ADD CREDIT NO MATTER OF GAME PLAY.	"OFF", "ON"	"ON"
SHOT INTERVAL	WAITING TIME FOR SHOOTNG NEXT TOKEN (PER SEC.)	0.3 ~ 1.0 (SEC.)	0.5
BELT SPEED	SET BELT MOVING SPEED.	-> SUB MENU (REFER TO THE TABLE #2 BELOW)	(REFER TO THE TABLE #2 BELOW)
SCORE TYPE * DIP	SET SCORE ON BELT	-> SUB MENU (REFER TO THE TABLE #3 BELOW)	(REFER TO THE TABLE #3 BELOW)
SENSOR DETAIL	SET DETAILS OF SCAN SENSOR OF BELT	-> SUB MENU (REFER TO THE TABLE #4 BELOW)	(REFER TO THE TABLE #4 BELOW)
SUPER BONUS * DIP	SET SUPER BONUS.	100 ~ 9999 (INCREASED BY 10)	2000
MERCY TICKET * DIP	SET MERCY TICKET QTY PER PLAY.	0 ~ 20 (INCREASED BY 1)	2
TICKET/SCORE	SET TICKET QTY PER SCORE. NONE: NO TICKET OUT PUT.	"NONE", "1/1", "1/2"	1/2
ATTRACT VOLUME	SET SOUND VOLUME. "OFF": NO SOUND. 10 ~ 100 : SOUND VOLUME	"OFF" , 10 ~ 100 (INCREASED BY 10)	60
SAVE AND EXIT	SAVE THE SET VALUE AND EXIT.	PUSH SELECT BUTTON TO PERFORM.	
CANCEL AND	CANCEL THE SET VALUE AND EXIT		

*** Default setting of DIP can be changed by setting of No.3, 4 DIP S/W (KSD04H).
For more information please refer to the below <DIP S/W DEFAULT SETTING>**

< DIP S/W DEFAULT SETTING >

◇ DEFAULT SETTING OF DIP CAN BE CHANGED BY SETTING OF NO.3, 4 DIP S/W (KSD04H).
(PLEASE REFER TO THE YELLOW ARROW ON DIP S/W OF LEFT PICTURE)

- We call A, B, C, D Type according to the DIP S/W setting.

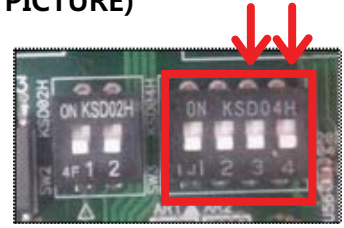

	A		B		C		D	
DIP 3	OFF		ON		OFF		ON	
DIP 4	OFF		OFF		ON		ON	
PLAYS / COIN	MINIMUM COIN	1	MINIMUM COIN	1	MINIMUM COIN	1	MINIMUM COIN	1
	1st. COIN	5	1st. COIN	5	1st. COIN	3	1st. COIN	1
	2nd. COIN	11	2nd. COIN	11	2nd. COIN	6	2nd. COIN	2
	3rd. COIN	18	3rd. COIN	18	3rd. COIN	9	3rd. COIN	3
	4th. COIN	24	4th. COIN	24	4th. COIN	12	4th. COIN	4
	5th. COIN	30	5th. COIN	30	5th. COIN	15	5th. COIN	5
SCORE TYPE	TYPE	3	TYPE	2	TYPE	7	TYPE	2
	LOW (ORANGE)	8	LOW (ORANGE)	10	LOW (ORANGE)	2	LOW (ORANGE)	10
	MIDDLE (GREEN)	16	MIDDLE (GREEN)	20	MIDDLE (GREEN)	4	MIDDLE (GREEN)	20
	HIGH (RED)	24	HIGH (RED)	30	HIGH (RED)	6	HIGH (RED)	30
SUPER BONUS	2000		2000		100		2000	
MERCY TICKET	2		2		0		2	
TICKET/SCORE	1/2		1/1		1/1		1/1	

< TABLE #1 >

<p>● PROGRAM SETTINGS -> PLAYS / COIN</p> <p>◇ SET PLAYS (CREDITS) PER COIN OR SWIPE.</p> <p>IN CASE OF SWIPING THE CARD REPEATEDLY TILL 5 TIMES WITHOUT ANY PLAY, PLAY QTY WILL BE INCREASED AS BELOW.</p> <p>FROM 6TH TIMES, IT WILL GO BACK TO 1ST COIN AGAIN. (5 times standard)</p>			
LCD DISPLAY	DESCRIPTION	RANGE	DEFAULT
MINIMUM COIN	SET MINIMUM COIN QTY FOR PLAY. "FREE": FREE GAME PLAY. EXAMPLE) IF MINIMUM COIN IS SET TO 5, 1st. COIN > 5 PLAYS: WHEN 5 COINS ARE INSERTED, 5 PLAYS ARE ALLOWED.	"FREE", 1 ~ 9 (INCREASED BY 1)	1
1st. COIN	SET PLAY QTY PER COIN.	1 ~ 100 (INCREASED BY 1)	5
2nd. COIN	SET PLAY QTY PER COIN.		11
3rd. COIN	SET PLAY QTY PER COIN.		18
4th. COIN	SET PLAY QTY PER COIN.		24
5th. COIN	SET PLAY QTY PER COIN.		30
SAVE AND EXIT	SAVE SET VALUE AND EXIT.	PUSH SELECT BUTTON TO PERFORM.	
CANCEL AND EXIT	CANCEL SET VALUE AND EXIT		

< TABLE #2 >

<p>● PROGRAM SETTINGS -> BELT SPEED</p> <p>◇ SET TOKEN BELT SPEED.</p> <p>ACCORDING TO TYPE SETTING, DETAIL SETTING MENU IS CHANGED TOWARD "RANDOM" AND OTHER ITEMS.</p>			
<p>▶ SETUP MENU FOR 'TYPE : <u>RANDOM</u></p> <p>※ IF "RANDOM" SPEED IS CHOSEN CONTINUE AND CHECK THE DESIRE SPEED TO CONTINUE FROM GAME START TO THE END.</p> <p>※ IF YOU CHOOSE ONLY 1 SPEED, THEN SPEED IS DECIDED ONLY THAT 1 SPEED.</p>			
LCD DISPLAY	DESCRIPTION	RANGE	DEFAULT
TYPE	SPEED IS SELECTED BETWEEN 5 KINDS; IF RANDOM IS SELECTED THEN SELECT THE DESIRE SPEEDS.	"RANDOM" "VERY SLOW" "SLOW" "NORMAL" "FAST" "VERY FAST"	"RANDOM"
PICK THE DESIRE SPEEDS FOR "RANDOM" SELECTION		([] : NOT CHECKED, [o] : CHECKED)	
VERY SLOW	VERY SLOW	[] or [o]	[o]
SLOW	SLOW	[] or [o]	[o]
NORMAL	NORMAL	[] or [o]	[o]
FAST	FAST	[] or [o]	[o]
VERY FAST	VERY FAST	[] or [o]	[o]
SAVE AND EXIT	SAVE THE SET VALUE AND EXIT. (SAVE IS ABLE AT LEAST 1 IS CHECKED)	PUSH SELECT BUTTON TO PERFORM.	
CANCEL AND EXIT	CANCEL THE SET VALUE AND EXIT		
<p>▶ SETUP MENU FOR 'TYPE : OTHER THAN RANDOM'</p> <p>(ALWAYS 1 SPEED AMONG "VERY SLOW", "SLOW", "NORMAL", "FAST", "VERY FAST")</p>			
LCD DISPLAY	DESCRIPTION	RANGE	DEFAULT
TYPE	FIXED SPEED AMONG BELOW "VERY SLOW" "SLOW" "NORMAL" "FAST" "VERY FAST"	"RANDOM" "VERY SLOW" "SLOW" "NORMAL" "FAST" "VERY FAST"	"RANDOM"
SAVE AND EXIT	SAVE THE SET VALUE AND EXIT.	PUSH SELECT BUTTON TO PERFORM.	
CANCEL AND EXIT	CANCEL THE SET VALUE AND EXIT		

< TABLE #3 >

● PROGRAM SETTINGS -> SCORE TYPE ✧ SET SCORE FOR EACH COLOR ON THE BELT. SET SCORE TYPE OR SET LOW, MIDDLE, HIGH SCORE SEPARATELY									
LCD DISPLAY	DESCRIPTION	RANGE	DEFAULT						
TYPE	REFER TO BELOW SCORE TABLE	1 ~ 9 (INCREASED BY 1)	3						
LOW (ORANGE)	SET LOW SCORE SEPARATELY (ORANGE COLOR)	1 ~ 100 (INCREASED BY 1)	8						
MIDDLE (GREEN)	SET MIDDLE SCORE SEPARATELY (GREEN COLOR)		16						
HIGH (RED)	SET HIGH SCORE SEPARATELY (RED COLOR)		24						
SAVE AND EXIT	SAVE THE SET VALUE AND EXIT.	PUSH SELECT BUTTON TO PERFORM.							
CANCEL AND EXIT	CANCEL THE SET VALUE AND EXIT								
<SCORE TABLE PER TYPE>									
TYPE	1	2	3	4	5	6	7	8	9
ORANGE (LOW)	14	10	8	6	6	4	2	2	1
GREEN (MIDDLE)	24	20	16	12	10	6	4	3	2
RED (HIGH)	40	30	24	20	16	10	8	4	3

< TABLE #4 >

● PROGRAM SETTINGS -> SENSOR DETAIL

◇ SET PROXIMITY RANGE OF SCAN SENSOR ON THE TOKEN BELT

BASED ON DEFAULT PROXIMITY SENSOR RANGE, YOU CAN SET MORE DETAIL PROXIMITY RANGE.

WHEN YOU GET INTO THE MODE OF SENSOR DETAIL IN THE SET-UP, THE TOKEN BELTS OF 1P AND 2P AUTOMATICALLY RUN.

WHEN YOU PRESS THE TOKEN SHOOTING BUTTON, THE TOKENS ARE DISPENSED. AT THIS TIME, YOU ARE ABLE TO PROCEED CALIBRATION OF THE TOKEN SENSOR BY MANUALLY PLACING THE TOKENS INSIDE THE WIN BOXES. PLEASE REFER TO "[TABLE #3]" HOW TO CALIBRATE THE SENSORS. YOU CAN SET UP THE ALLOWANCE RANGE OF SENSING TOKENS OVER THE BOXES.

YOU ARE ABLE TO SEE THE WIN OR FAIL IN SEEING THE FIRST DIGIT OF TICKET FND. IF THE FIRST DIGIT SHOWS "1", IT MEANS TOKEN IS LOCATED OUT BOX. ACCORDING TO THIS RESULT YOU CAN PROCEED THE CALIBRATION OF THE TOKEN SENSOR.

THE 3RD DIGIT MEANS THE NUMBER OF BOX.

5 MEANS CAED OUT. 2 MEANS ORANGE BOX. 3 MEANS GREEN BOX. 4 MEANS RED BOX.

1 : NG 2 : ORANGE (LOW) 3 : GREEN (MIDDLE) 4 : RED (HIGH)
5 : WIN CARD

LCD DISPLAY	DESCRIPTION	RANGE	DEFAULT
1P OFFSET START	1P SENSING RANGE FOR INNER LINE	-7 ~ 0 ~ +7 (INCREASED BY 1)	0
1P OFFSET END	1P SENSING RANGE FOR OUTER LINE		0
2P OFFSET START	2P SENSING RANGE FOR INNER LINE		0
2P OFFSET END	2P SENSING RANGE FOR OUTER LINE		0
SAVE AND EXIT	SAVE SET VALUE AND EXIT (This This calibration status is not changed by Factory Default setting.)	PUSH SELECT BUTTON TO PERFORM.	
CANCEL AND EXIT	CANCEL THE SET VALUE AND EXIT		

! CAUTION - If you set "--" to START and END both, CARD WIN may not be functioned.

☆ The setting values of (Token) Sensor Detail are not changed by Factory Set. When the Token Sensor PCB is disassembled or replaced with different one, proceed Calibration and set the values according to the picture below.

> Reference



If the range value is up, the win box's area is increased.

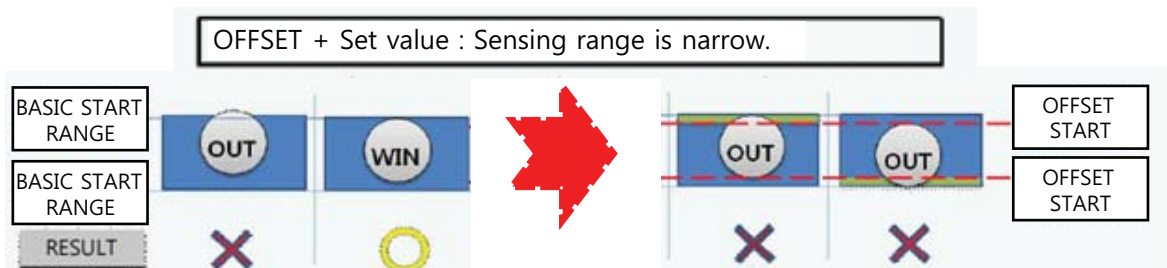

If the range value is down, the win box's area is decreased.

4-3. CLEAR MODE

◇ TO CLEAR OR DELETE GAME DATA & BOOKKEEPING.		
LCD DISPLAY	DESCRIPTION	RUN
CLEAR TICKETS	CLEAR NUMBER OF TICKETS THAT SHOULD BE PAID NOW	PUSH SELECT BUTTON TO PERFORM.
CLEAR PLAYS	CLEAR DATA OF CURRENT PLAY. (CLEAR CARD NUMBER SHOULD BE PAID ALSO)	
CLEAR DATA	CLEAR ALL OF GAME DATA AND BOOKKEEPING DATA	
EXIT	EXIT	

● BOOKKEEPING	
LCD DISPLAY 1P : 1 Player 2P : 2 Player TOTAL : SUM UP 1P, 2P	DESCRIPTION
----- COIN IN ----- 1P: 0 2P: 0 TOTAL: 0	TOTAL COIN IN.
----SERVICE IN---- 1P: 0 2P: 0 TOTAL: 0	TOTAL SERVICE IN. IF YOU PRESS SERVICE IN BUTTON FOR EACH PLAYER SIDE.
----- GAME PLAYS ----- 1P: 0 2P: 0 TOTAL: 0	TOTAL GAME PLAY COUNT.
----- TICKET OUT ----- 1P: 0 2P: 0 TOTAL: 0	NUMBER OF TOTAL TICKET OUT.
-- WIN CARD DROP -- 1P: 0 2P: 0 TOTAL: 0	TOTAL WON CARD DROP.
- WIN TICKET LOW - 1P: 0 2P: 0 TOTAL: 0	TOTAL WON LOW TICKET NUMER.
- WIN TICKET MIDDLE - 1P: 0 2P: 0 TOTAL: 0	TOTAL WON MIDDLE TICKET NUMBER.
-- WIN TICKET HIGH - 1P: 0	TOTAL WON HIGH TICKET NUMBER.

● **FACTORY-SETTING**

CLEAR ALL DATA AND SET BACK TO FACTORY DEFUALT SETTING

**! Default setting of DIP can be changed by setting of No.3, 4 DIP S/W (KSD04H).
For more information please refer to the below <DIP S/W DEFAULT SETTING>**

☆ The setting values of Token Sensor are not changed by Factory Set.

LCD DISPLAY	LCD DISPLAY
<p>FACTORY-SETTING ARE YOU SURE? YES or [<u>NO</u>]</p>	<p>FACTORY-SETTING REALLY? YES or [<u>NO</u>]</p>

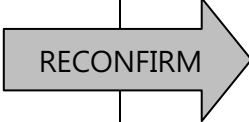

4-4. TEST MODE

TEST MODE			
TEST	SETTING	DESCRIPTION	
1. INPUT TEST	[=>]	ENTER INPUT TEST	
		INPUT CONDITION IS ON LCD DISPLAY	
		(BUTTON, COIN, TICKET, SENSOR... ETC)	
2. FND & LAMP		LAMP, FND, LED TEST	
	"OFF"	WHOLE FND & LAMP OFF	
	"STEP"	LAMP	<ul style="list-style-type: none"> ▶ WHOLE LAMP FLICKERING ▶ 1P TICKET LAMP ON ▶ 2P TICKET LAMP ON ▶ 1P BUTTON LAMP ON ▶ 2P BUTTON LAMP ON REPEAT
		FND	<ul style="list-style-type: none"> ▶ WHOLE LAMP FLICKERING ▶ WHOLE NUMBER COUNTING [0000] ~ [9999] ▶ 1P PLAYS FND [00], 1P TICKET FND [222] ▶ 2P PLAYS FND [11], 2P TICKET FND [333] ▶ SUPER BONUS FND [0000] REPEAT
		LED	<ul style="list-style-type: none"> ▶ WHOLE WHITE LED FLICKERING ▶ RED ▶ GREEN ▶ BLUE ▶ WHITE LED ON ▶ EACH TYPE OF LED IS ON FROM RED COLOR. (SEPARATE LED SUCH AS BUTTON PLATE SIDE, MAIN WHEEL PLATE OR TOP MARQUEE IS ONLY RED LED) REPEAT
	"ON"	WHOLE FND & LAMP ON (THIS WILL LAST IF YOU MOVE TO ANOTHER TEST MODE.)	
	"ON/OFF"	WHOLE FND & LAMP ON AND OFF REPEATEDLY	
3. TOKEN SENSOR	=>	ENTER TOKEN SENSOR DETAIL 1P, 2P TOKEN BELT MOVE TO WHITE AREA FOR SENSOR CHECK	
	TOKEN SENSOR DETAIL FEDCBA9876543210 1P:0000000000000000 2P:0000000000000000 (FEDCBA987654321 : TOKEN SENSING SENSOR) (0 : MAIN POSITION SENSOR)	DISPLAY 0 AND 1 FOR EACH 16 SENSORS. 0 – NO SIGNAL, 1 – SIGNAL IS ON 1P TOKEN IR SENSOR CONDITION DISPLAY 2P TOKEN IR SENSOR CONDITION DISPLAY * The right-end number(zero digit) could become "1" according to the starting check point.	
	TICKETS FND : [■□□] : DISPLAY TOKEN & POSITION SENSOR SIGNAL 1 – POSITION SENSOR SIGNAL 2 – TOKEN SENSOR SIGNAL 3 - TOKEN & POSITION SENSOR SIGNAL [□■■] : EACH SENSOR CONDITION DISPLAY (0 ~ 15)		

4. TOKEN BELT	MAIN GAME BELT TEST ◎ CHOOSE TEST BY LEFT, RIGHT BUTTON AND RUN BY SELECT BUTTON	
	"ALL"	1P, 2P TOKEN BELT
	"1P"	1P TOKEN BELT
	"2P"	2P TOKEN BELT
	PLAYS FND : DISPLAY ON, OFF MOTOR CONDITION TICKETS FND : [■□□] : TOKEN SENSING KINDS NUMBER 5 - WIN CARD 4,3,2 - TICKETS (High, Middle, Low) 1 - OUT [□■■] : DISPLAY BELT SCORE LOCATION NUMBER (0 ~ 19) SP-BONUS FND : [■■□□] : DISPLAY 1P BELT ENCODER COUNT [□□■■] : DISPLAY 2P BELT ENCODER COUNT	
5. CARD BELT	MAIN GAME BELT TEST ◎ CHOOSE TEST BY LEFT, RIGHT BUTTON AND RUN BY SELECT BUTTON	
	"ALL"	1P, 2P CARD BELT
	"1P"	1P CARD BELT
	"2P"	2P CARD BELT
	1P, 2P TICKETS FND : [■□□] : DISPLAY CARD OUT SENSOR CONDITION (0, 1) [□■□] : DISPLAY BELT CARD POINT SENSOR CONDITION (0, 1) [□□■] : DISPLAY BELT MOTOR ENCODER CONDITION (0, 1) SP-BONUS FND : [■■□□] : DISPLAY 1P COUNT OF BELT ENCORDER [□□■■] : DISPLAY 2P COUNT OF BELT ENCORDER	
6.TOKEN OUT	COIN HOPPER TEST ◎ CHOOSE TEST BY LEFT, RIGHT BUTTON AND TEST BY SELECT BUTTON	
	"1P"	1 COIN OUT FROM COIN HOPPER
	"2P"	2 COIN OUT FROM COIN HOPPER
	"ALL"	CONTINUOUSLY COIN OUT FROM COIN HOPPER
	PLAYS FND : DISPLAY ON, OFF OF HOPPER CONDITION TICKETS FND : DISPLAY NUMBER OF CARD TO BE OUT S-P BONUS FND : [■□□□] : DISPLAY 1P CONDITION OF HOPPER SENSOR (0, 1) [□□□■] : DISPLAY 2P CONDITION OF HOPPER SENSOR (0, 1)	
7. CARD OUT (Card Dispenser)	CARD DISPENSER TEST	
	"ALL"	1PC OF CARD OUT FROM 1P, 2P
	"1P"	1PC OF CARD OUT FROM 1P
	"2P"	1PC OF CARD OUT FROM 2P
	PLAYS FND : DISPLAY ON, OFF OF HOPPER CONDITION TICKETS FND : DISPLAY NUMBER OF CARD TO BE OUT S-P BONUS FND : [■□□□] : DISPLAY 1P CONDITION OF CARD DISPENSER (0, 1) [□□□■] : DISPLAY 2P CONDITION OF CARD DISPENSER (0, 1)	

8. COIN	COIN MACHINE TEST	
	"ON", "OFF"	COIN MACHINE ON, OFF
	PLAYS FND : DISPLAY COUNT OF COIN SENSOR TICKETS FND : DISPLAY WORK OF COIN MACHINE S-P BONUS FND : DISPLAY CONDITION OF COIN SENSOR	
9. TICKET	TICKET MACHINE TEST ⊙ CHOOSE TEST BY LEFT, RIGHT BUTTON AND TEST BY SELECT BUTTON ⊙ 1P, 2P SERVICE BUTTON FOR EACH TICKET DISPENSOR (5 TICKETS OUT)	
	"ALL"	TEST OF TICKET DISPENSER FOR WHOLE PLAYER (BASIC 5PCS OUT)
	"1P", "2P",	TEST OF TICKET DISPENSER FOR EACH PLAYER (5PCS OUT)
	PLAYS FND : DISPLAY CONDITION OF TICKET BUTTON & SENSOR TICKETS FND : DISPLAY CONDITION OF TICKET MACHINE & TICKET OUT NUMBER	
10. COUNTER	COUNTER TEST ⊙ CHOOSE TEST BY LEFT, RIGHT BUTTON AND PRESS SELECT BUTTON (1 COUNT UP)	
	"COIN"	COIN COUNTERS OF WHOLE PLAYER WORK IN ORDER OF 1P ► 2P, 1 COUNT IS UP
	"TICKET"	TICKET COUNTERS OF WHOLE PLAYER WORK IN ORDER OF 1P ► 2P, 1 COUNT IS UP
11. SOUND TEST	SOUND TEST ⊙ CHOOSE TEST BY LEFT, RIGHT BUTTON AND TEST BY SELECT BUTTON (PLAY, STOP)	
	"CH"	EACH CHANNEL SPEAKER TEST LEFT 1, 3, 5, 7 RIGHT 2, 4, 6, 8
	"BGM"	BGM VOLUME TEST
	"SFX"	SOUND EFFECT VOLUME TEST
	"VOC"	VOICE VOLUME TEST
EXIT	EXIT TO OPERATING OPTIONS	

4-5. ERROR CODE

ERROR CODE	CATEGORY OF ERROR	DESCRIPTION	CHECK POINT
E.02	SYSTEM	FAILURE OF SETUP SAVE DATA MEMORY READ & WRITE	STILL PROBLEM AFTER POWER OFF & ON, REPLACE MAIN BOARD.
E.03		PROBLEM ON SETUP SAVE DATA	1. SETUP SETTING CHECK & SAVE 2. STILL PROBLEM AFTER NO.1, AND TURN OFF & ON. REPLACE MAIN BOARD.
E.04		FAILURE OF GAME SAVE DATA MEMORY READ & WRITE	STILL PROBLEM AFTER POWER OFF & ON, REPLACE MAIN BOARD.
E.11	COIN ACCEPTOR	SIGNAL OF PLAYER COIN SENSOR IS CONTINUOUSLY ON.	CHECK INPUT OF ACCEPTOR
E.31	MAIN GAME BELT MOTOR	NO ENCODER SIGNAL	1. CHECK MOTOR OPERATION 2. CHECK INPUT OF THE ENCODER SENSOR.
E.41	CARD BELT DROP MOTOR	NO ENCODER SIGNAL	1. CHECK MOTOR OPERATION 2. CHECK INPUT OF ENCODER SENSOR
E.43		SENSOR SIGNAL OF CARD DROP IS CONTINUOUSLY ON	1. CHECK MOTOR OPERATION 2. CHECK CARD DROP SENSOR
E.44		NO SIGNAL OF THE CARD DROP SENSOR	3. CHECK CARD JAM ON BELT
E.51	BELT SCAN SENSOR	PROBLEM ON MAIN POSITION SENSOR	1. CHECK WORKING STATUS OF THE MAIN POSITION SENSOR 2. CHECK WORKING STATUS OF THE TOKEN BELT MOTOR
E.52		PROBLEM ON COIN SENSOR	1. CHECK WORKING STATUS OF TOKEN SENSING SENSOR 2. CHECK WORKING STATUS OF THE TOKEN BELT MOTOR 3. CHECK IF THE TOKEN IS STUCK IN THE TOKEN FLOW SYSTEM (HOPPER & GUIDE RAIL)
E.61	TOKEN DROP HOPPER	NO TOKEN OUT (EMPTY) OR HOPPER JAM	1. CHECK IF TOKEN BOX IS EMPTY 2. CHECK INPUT OF TOKEN OUT SENSOR.
E.62		SIGNAL OF TOKEN OUT SENSOR IS CONTINUOUSLY ON TOKEN FLOW SYSTEM JAM CHECK	1. CHECK IF TOKEN IS JAMMED 2. CHECK INPUT OF TOKEN OUT SENSOR
E.81	CARD DISPENSER	CARD DISPENSER SIGNAL IS CONTINUOUSLY ON OR NO CARD	1. CHECK CARD 2. CHECK CARD DISPENSER
E-t	TICKET ERROR	NO TICKET	1. CHECK TICKET 2. CHECK TICKET MOTOR 3. CHECK TICKET OUT SENSOR

※ BASICALLY, ALL ERROR CODES ARE DISPLAYED ON THE "TICKET FND" AT THE SIDE OF ERROR PLAYER.

* THE CHECKING METHOD FOR THE WRONGLY WORKING SENSOR

- In case the sensor wrongly decide as a success although the token is located out of the box.
- In case the sensor could not recognize the tokens.

In case of these problems, check out as following method.

1) Get into the TOKEN SENSOR of the TEST MODE of MENU/SELECT

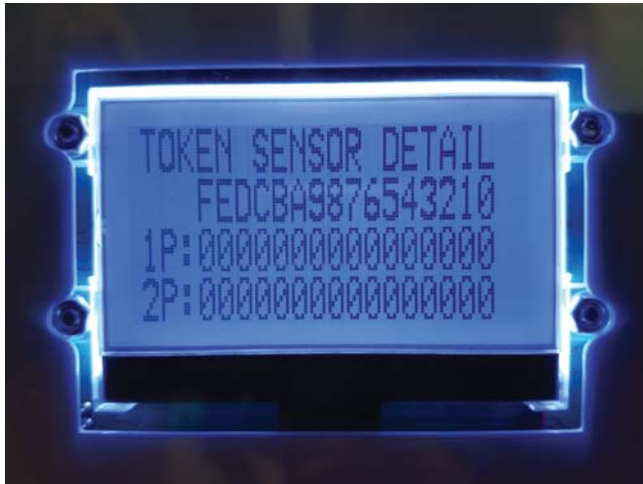

2) Set the supplied Bracket to the right-end side below the TOKEN CHECK SENSOR ASS'Y as the shown picture.

If "0" is changed to "1" in the TOKEN SENSOR of the TEST MODE, it is normal.

If "0" is not changed to "1" in the TOKEN SENSOR of the TEST MODE,

proceed the SENSOR calibration. If it could not be solved in the calibration, replace it with new one.

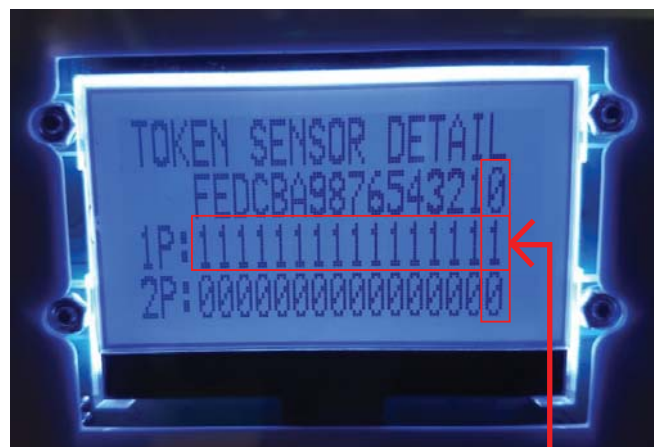
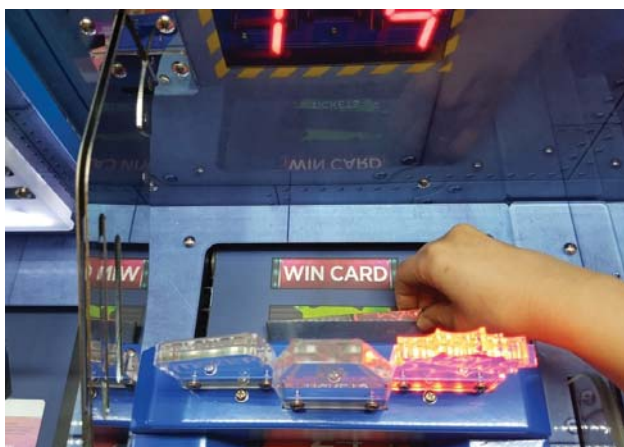

★ If "E51" error does not happen in the said "0"'s position sensor during the game it can be used regardless "0" or "1".

* CHECKING METHOD OF DM JELLY'S TOKEN SENSOR PCB

1) Explanation on Token Check Sensor PCB

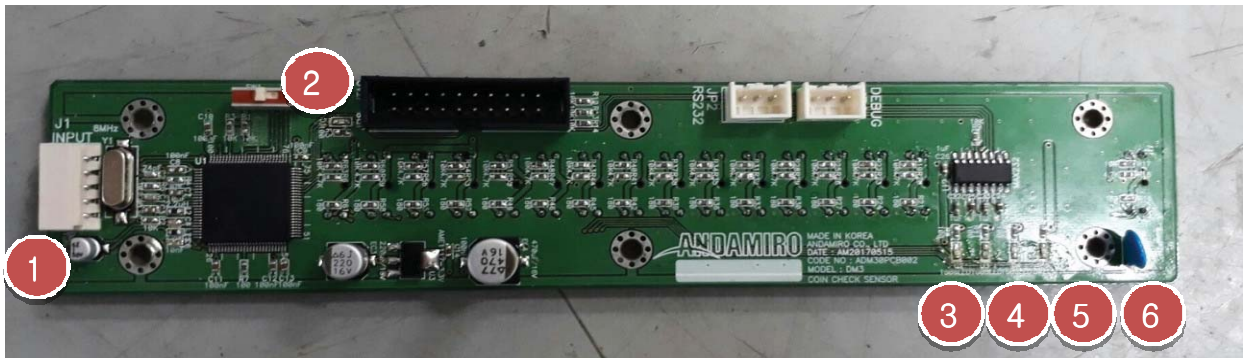

NO	NAME	NORMAL MODE	CAL MODE
1	Communication Port	Communication with the Main Board	
2	SYSTEM LED	LED lighting every 1 sec when the Sensor PCB is ON. LED lighting every 30 sec when the Sensor PCB is OFF.	LED lighting every 1 sec
3	TEST LED1	Level 1 of token recognition	ON if the 1st calibration does work
4	TEST LED2	Level 2 of token recognition	ON if the 2nd calibration does work
5	TEST LED3	Level 3 of token recognition	LED lighting every 1 sec
6	ENCODE LED	ON in the winning box	Always OFF

2) Checking the status of SENSOR

- Get into the Token Sensor Test Mode in the set-up mode

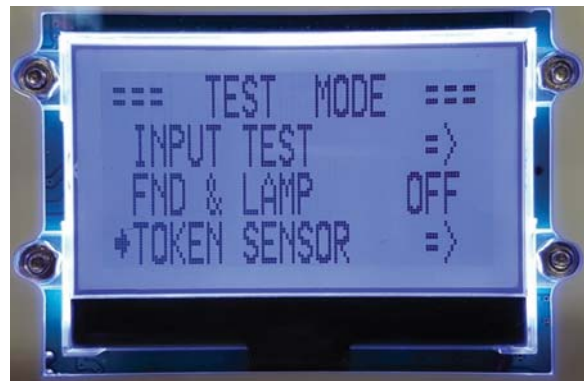
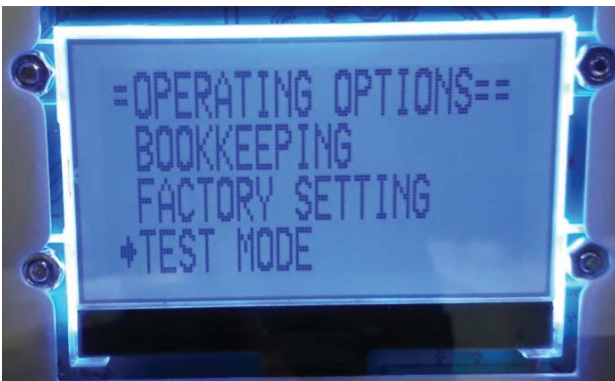

- Place an object of the same thickness & color with the token on the belt
The object should cover all the sensors.



* "O" means the sensor does not work.
In the left picture, all 1P sensors do not work.
And B,A & 9 sensors in 2P sensor work.

3) Calibration Method

- Disassemble the 3 kinds of token indication acryl and Token Check LED PCB.
- Get into the Token Sensor Test Mode (The conveyor belt automatically moves)
- The sensor PCB is being close to the belt when the bolt is screwed counterclockwise.

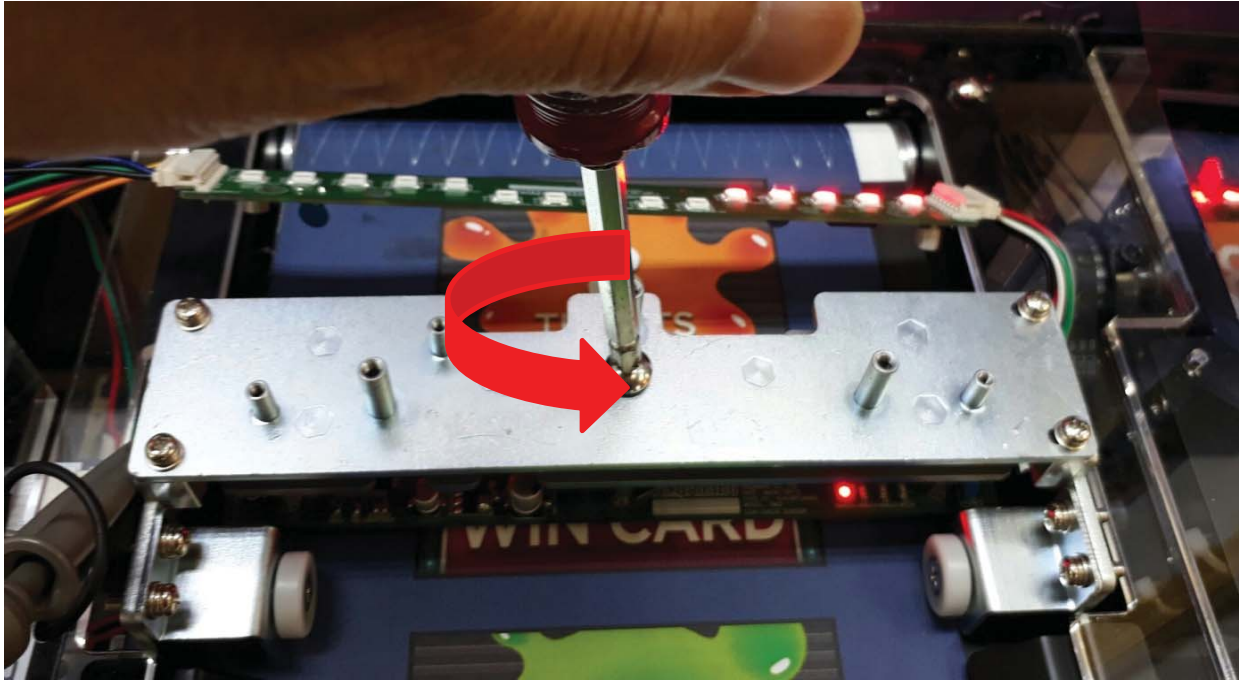

- Rotate the screwdriver clockwise to raise the sensor PCB to the maximum. (Minimum 8mm or more)
- Turn counterclockwise again so that the sensor is closest to the belt.

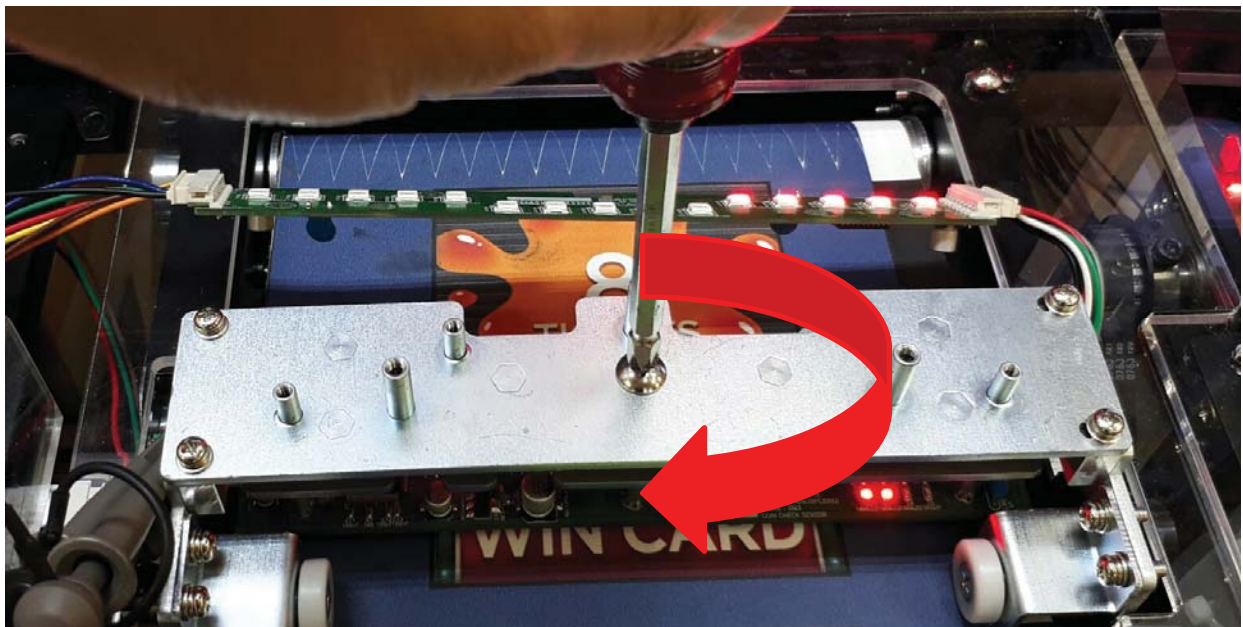

- Rotate the screwdriver in the clockwise direction until all Test LEDs 1 and 2 are ON. (Sensor calibration completion status)
 - ※ If the LEDs 1,2 are turned off after the adjustment is completed, there is no big problem in operation.
- After the sensor calibration completes, set the "TOKEN BELT" ON state of the TEST MODE (no coin on the belt).
If one of the test LEDs 1, 2, or 3 in the picture is momentarily lit, turn the screwdriver clockwise so that the LED is always off so that the sensor PCB is slightly away from the belt.

5. TROUBLESHOOTING

5-1. CREDIT FND PCB ERROR

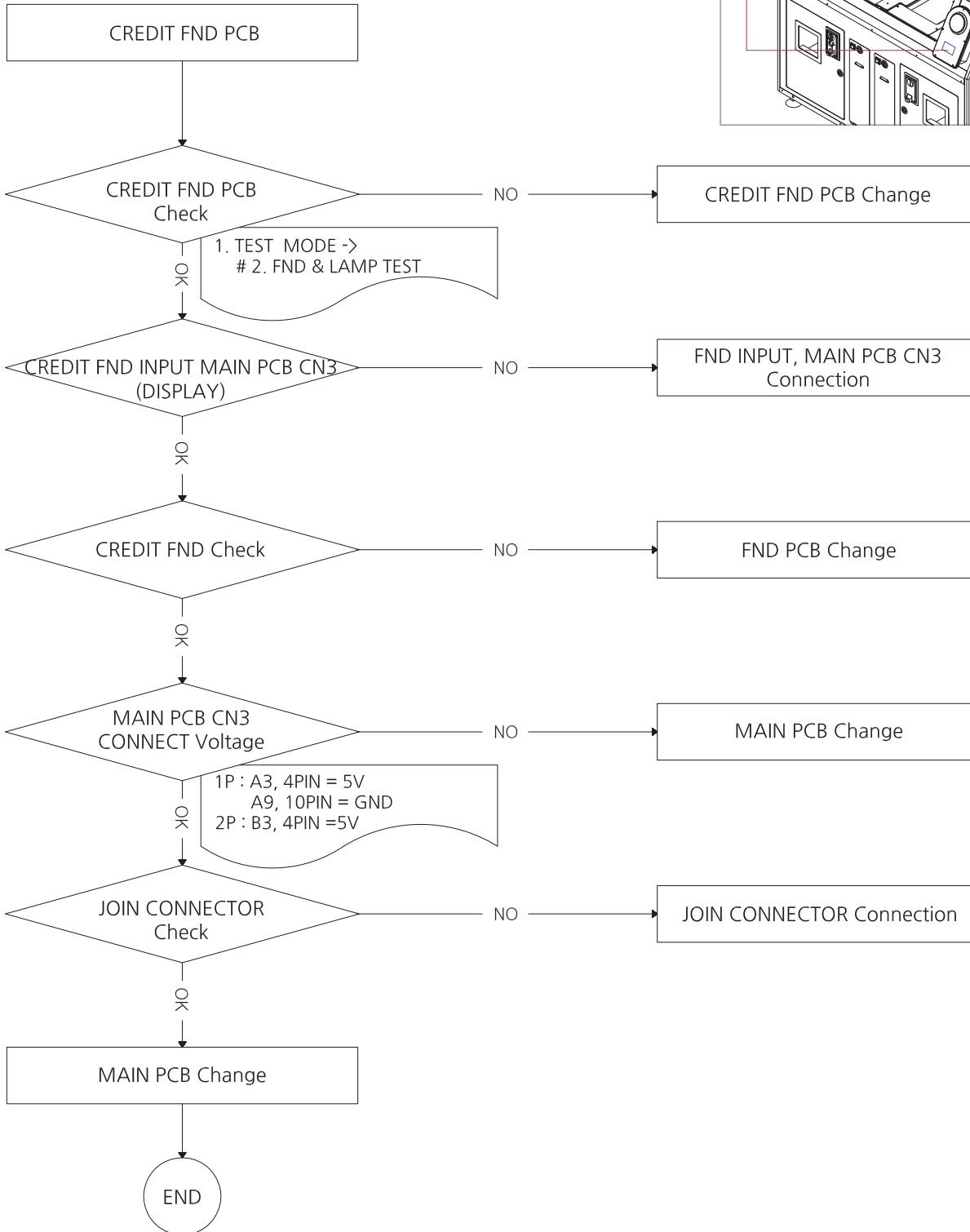
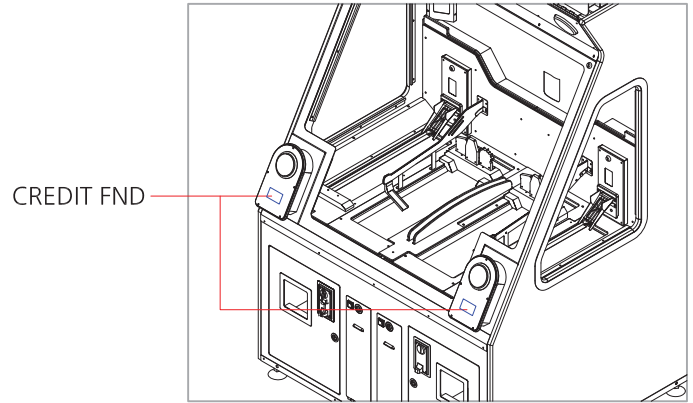

5-2. 1P TICKET FND PCB ERROR

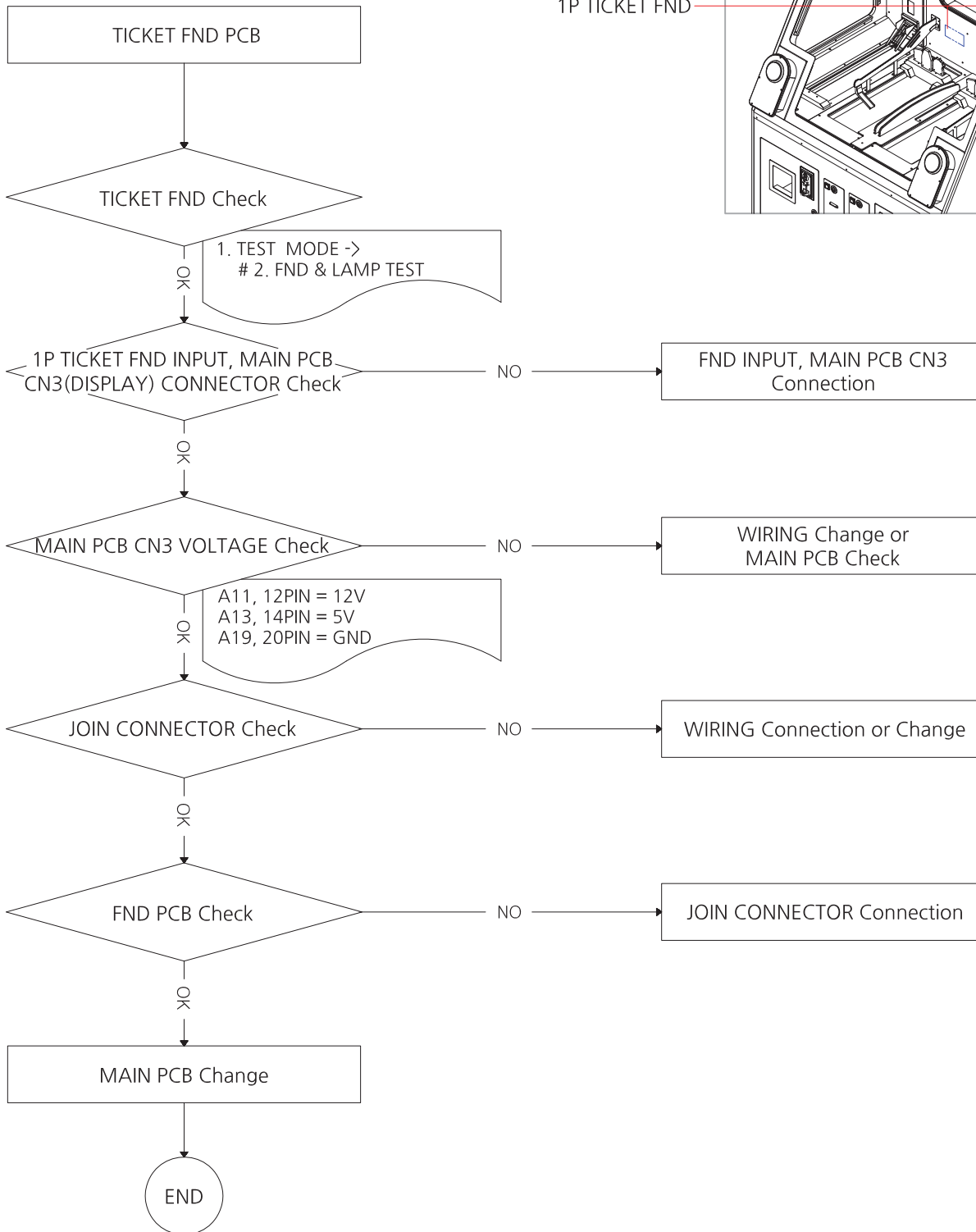

1P TICKET FND

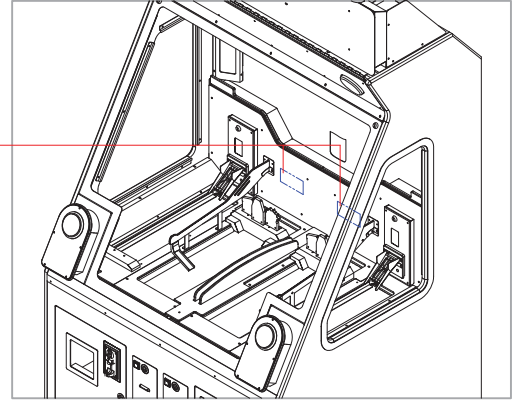

5-3. 2P TICKET FND PCB ERROR

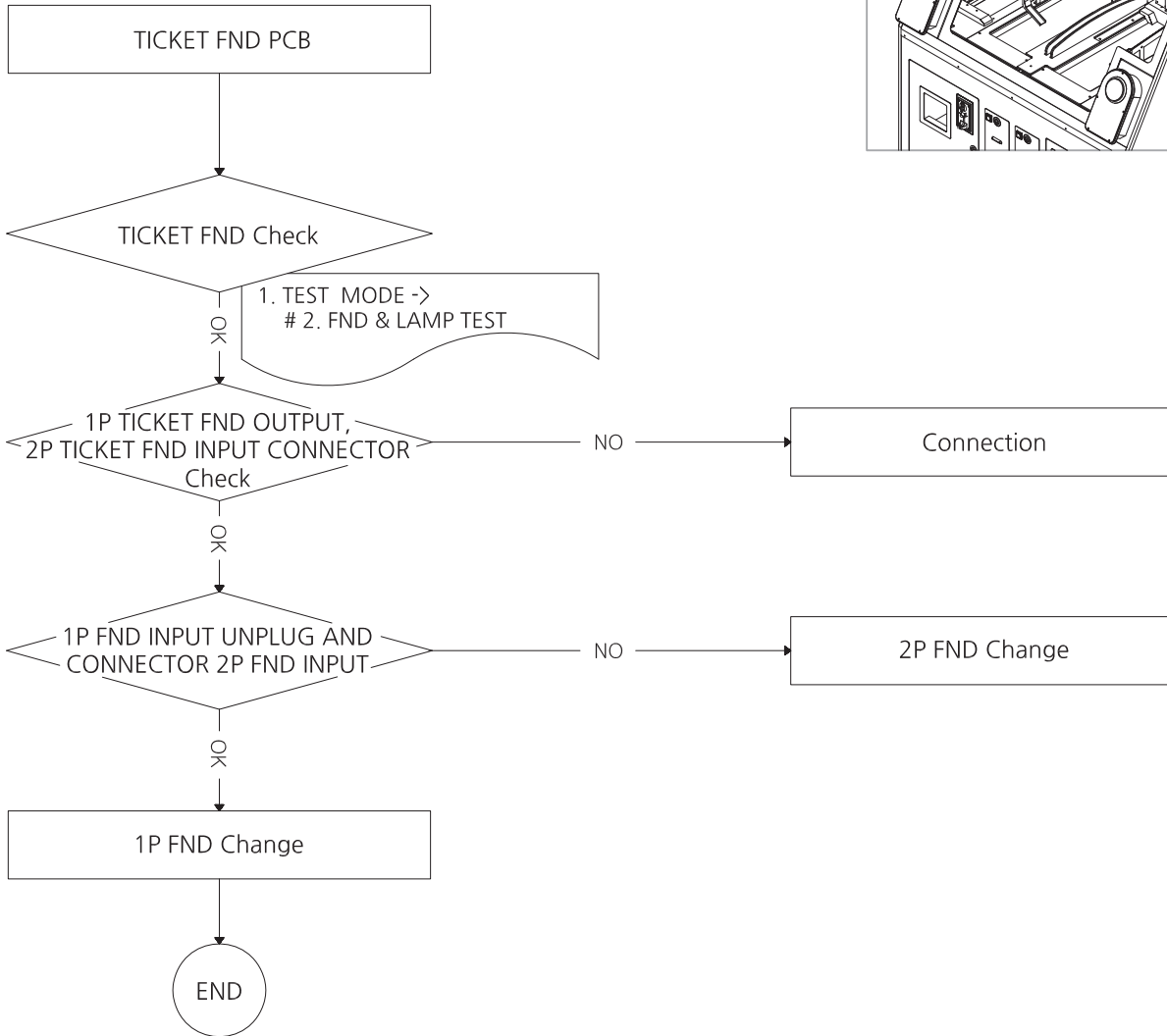
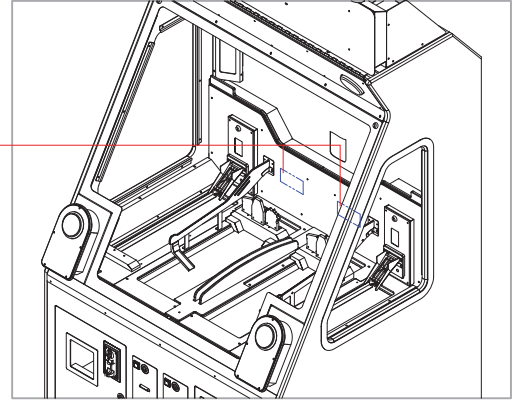

5-4. JACKPOT FND PCB ERROR

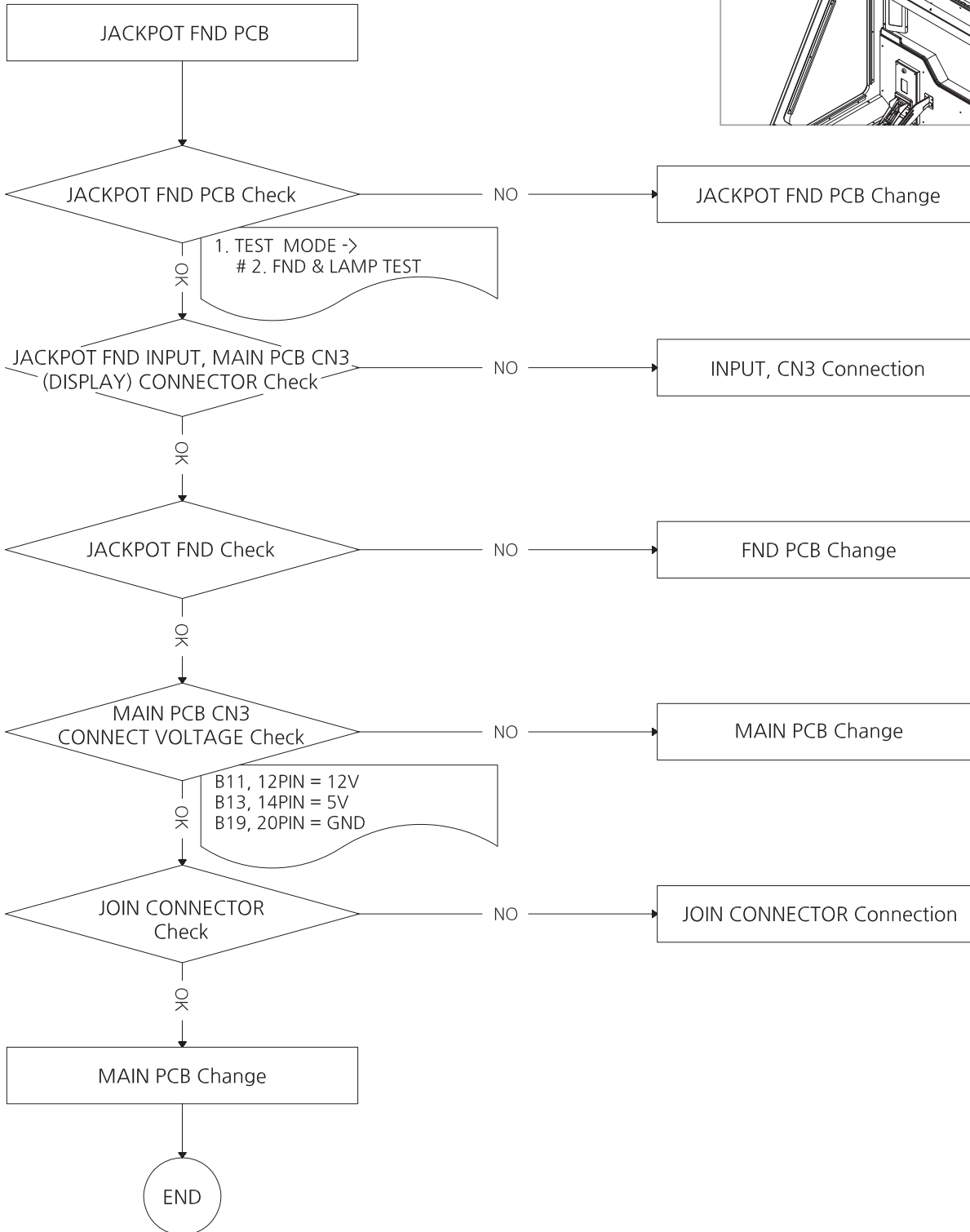
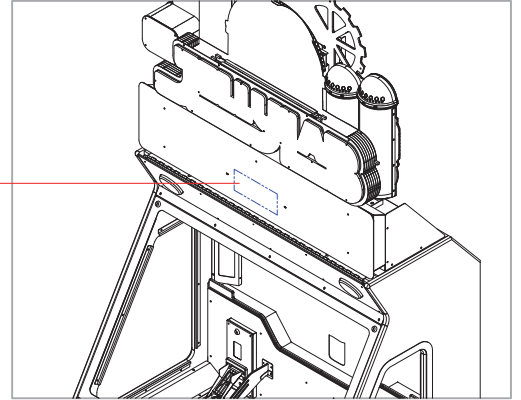

5-5. COIN SELECTOR ERROR [1~2P] - E.11

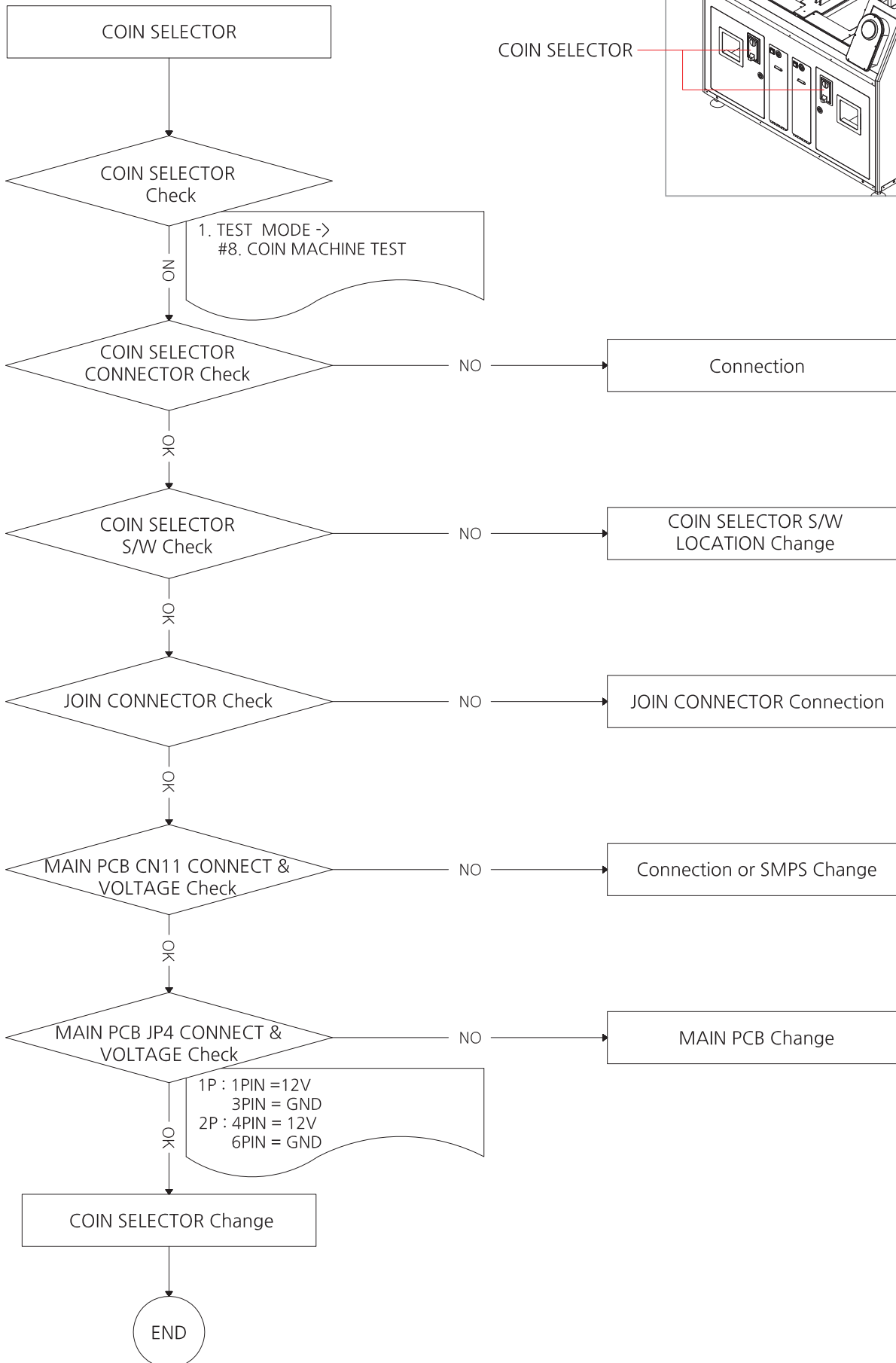

COIN SELECTOR

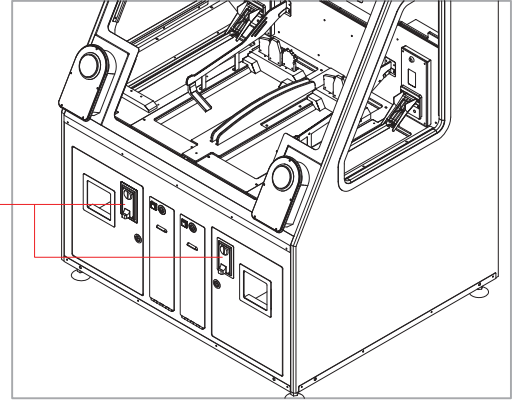

5-6. MAIN GAME BELT MOTOR ERROR [1~2P] - E.31

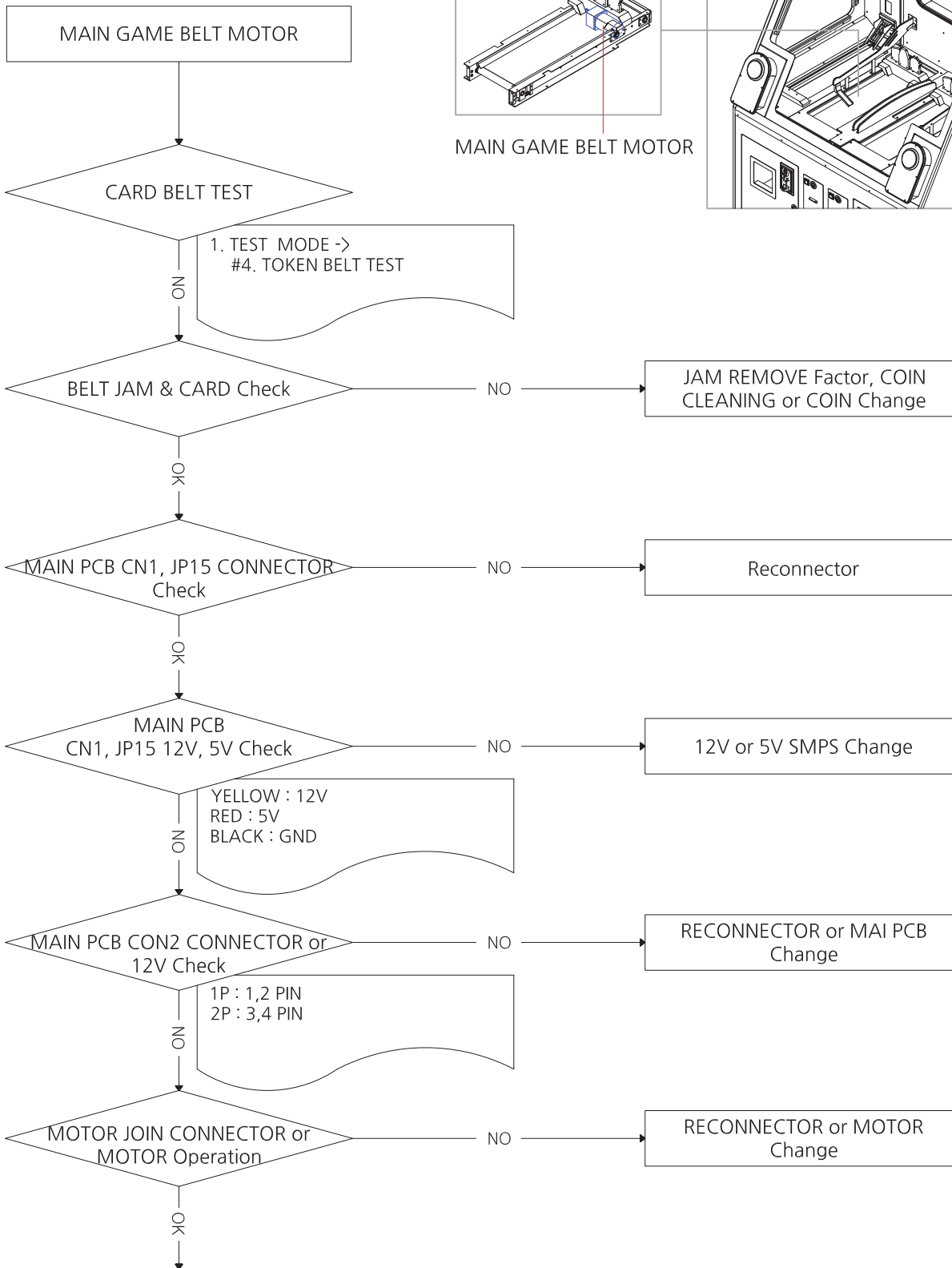

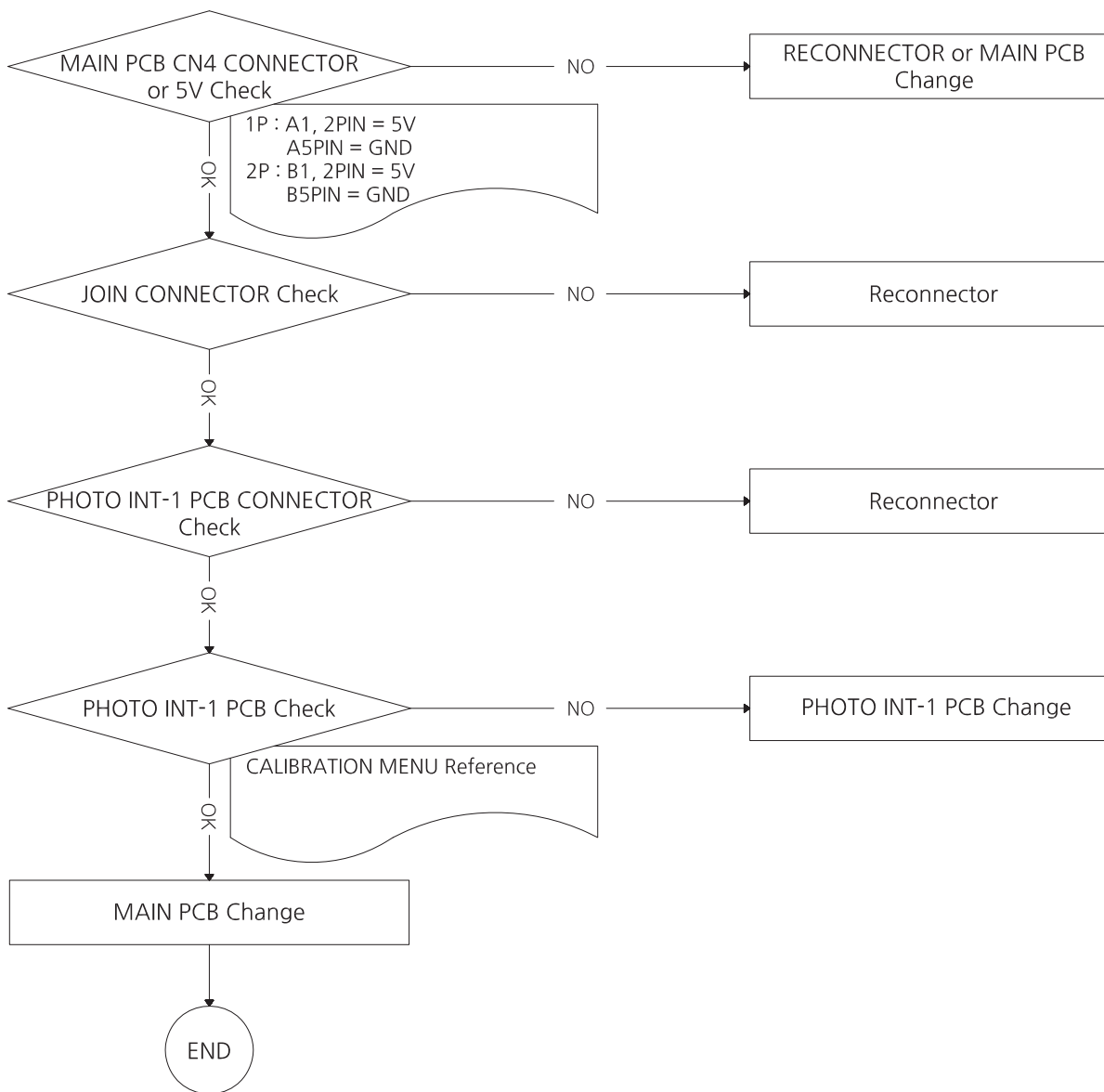

5-7. CARD BELT DROP MOTOR ERROR [1~2P] - E.41 / E.43 / E.44

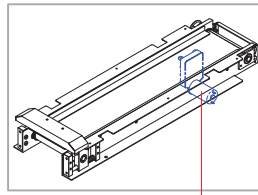

CARD BELT DROP MOTOR

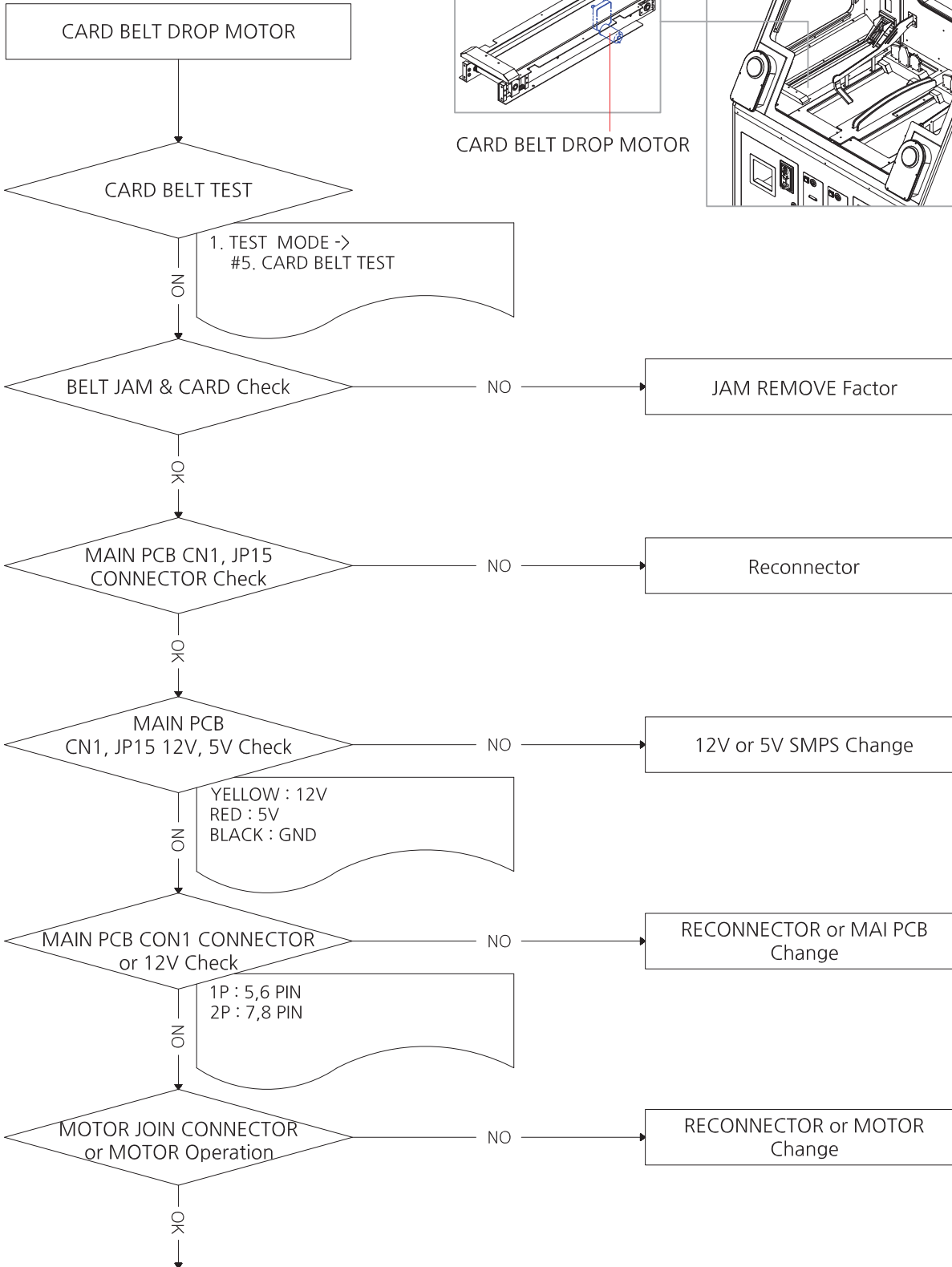
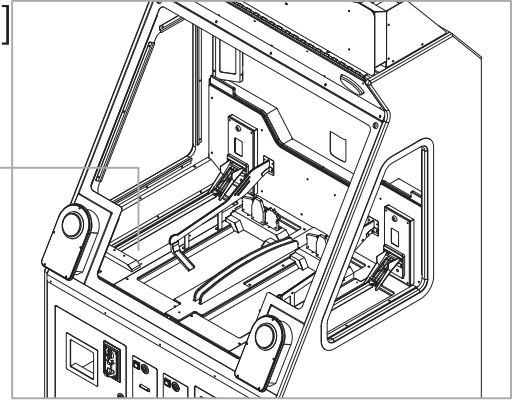

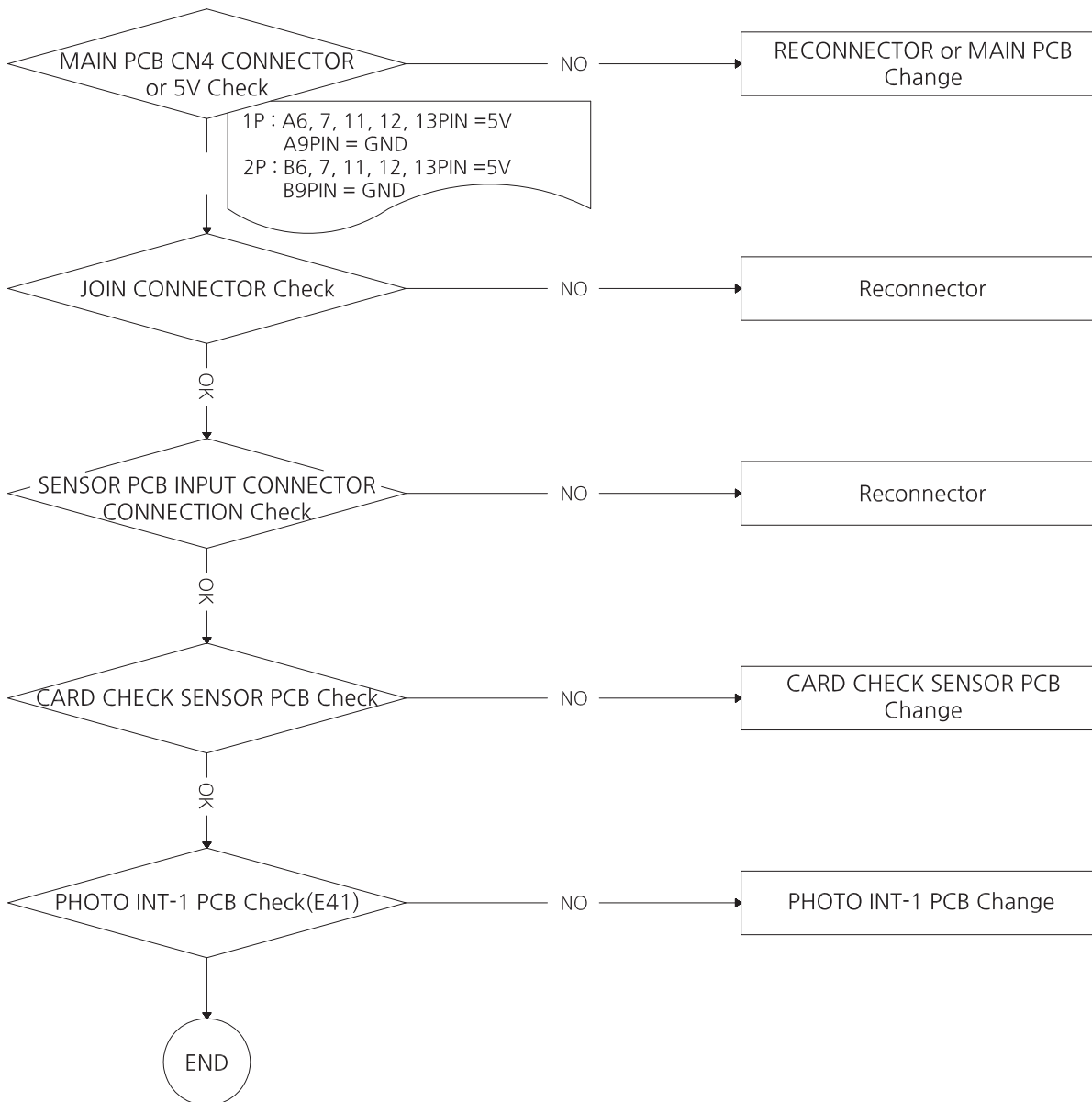

5-8. BELT SCAN SENSOR ERROR [1~2P] - E.51 / E.52

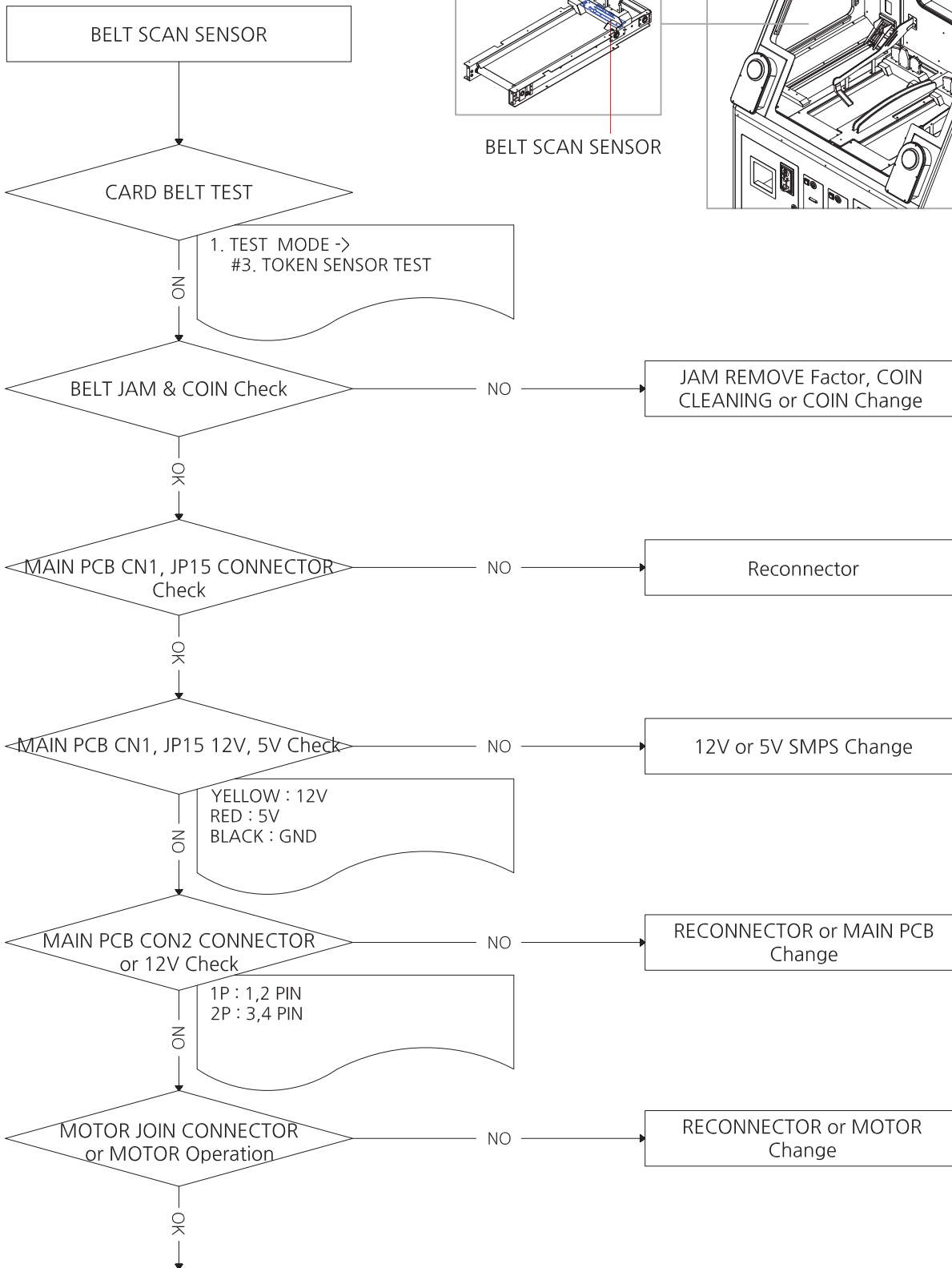

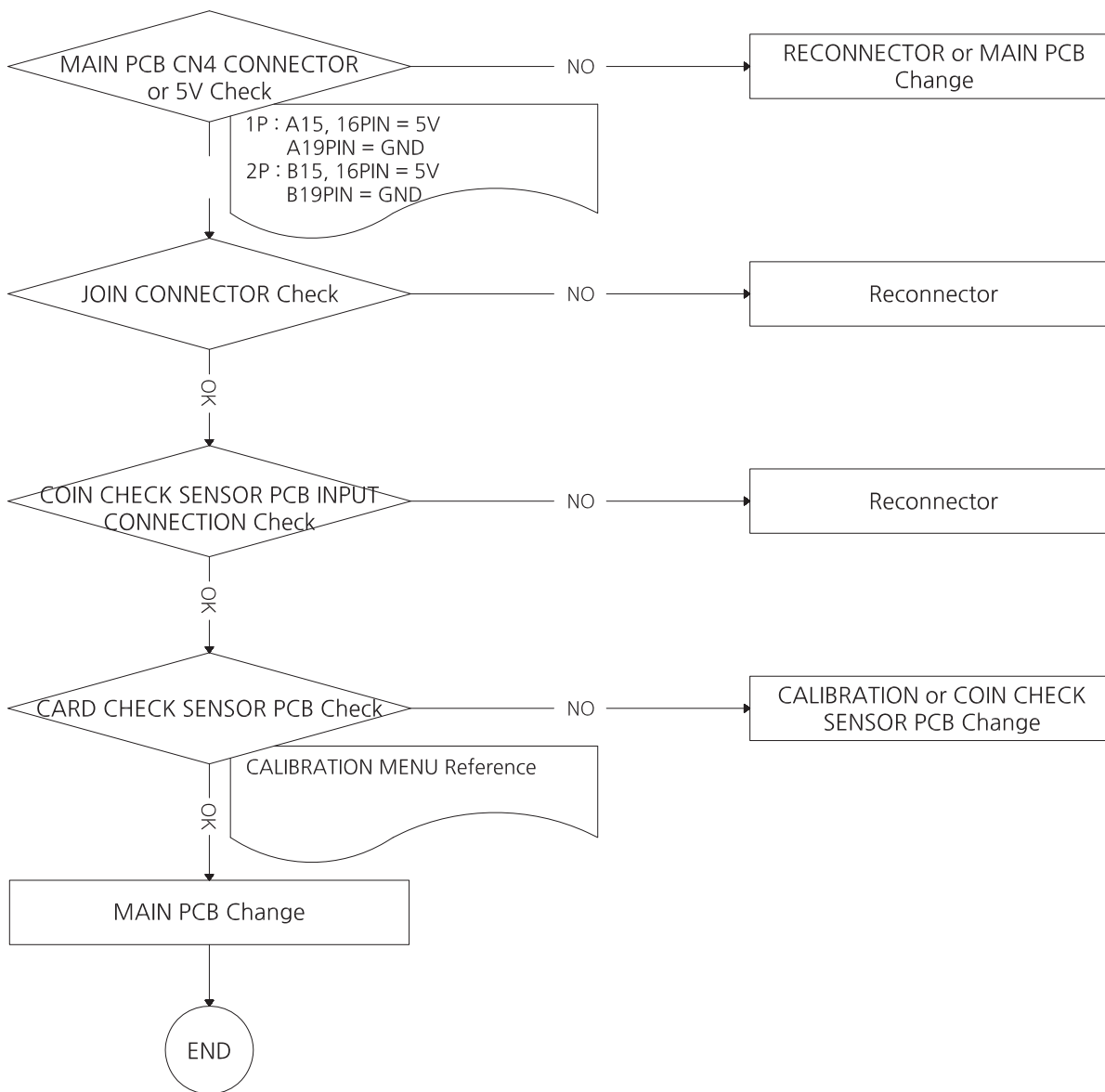

5-9. TOKEN DROP HOPPER ERROR [1~2P] - E.61 / E.62

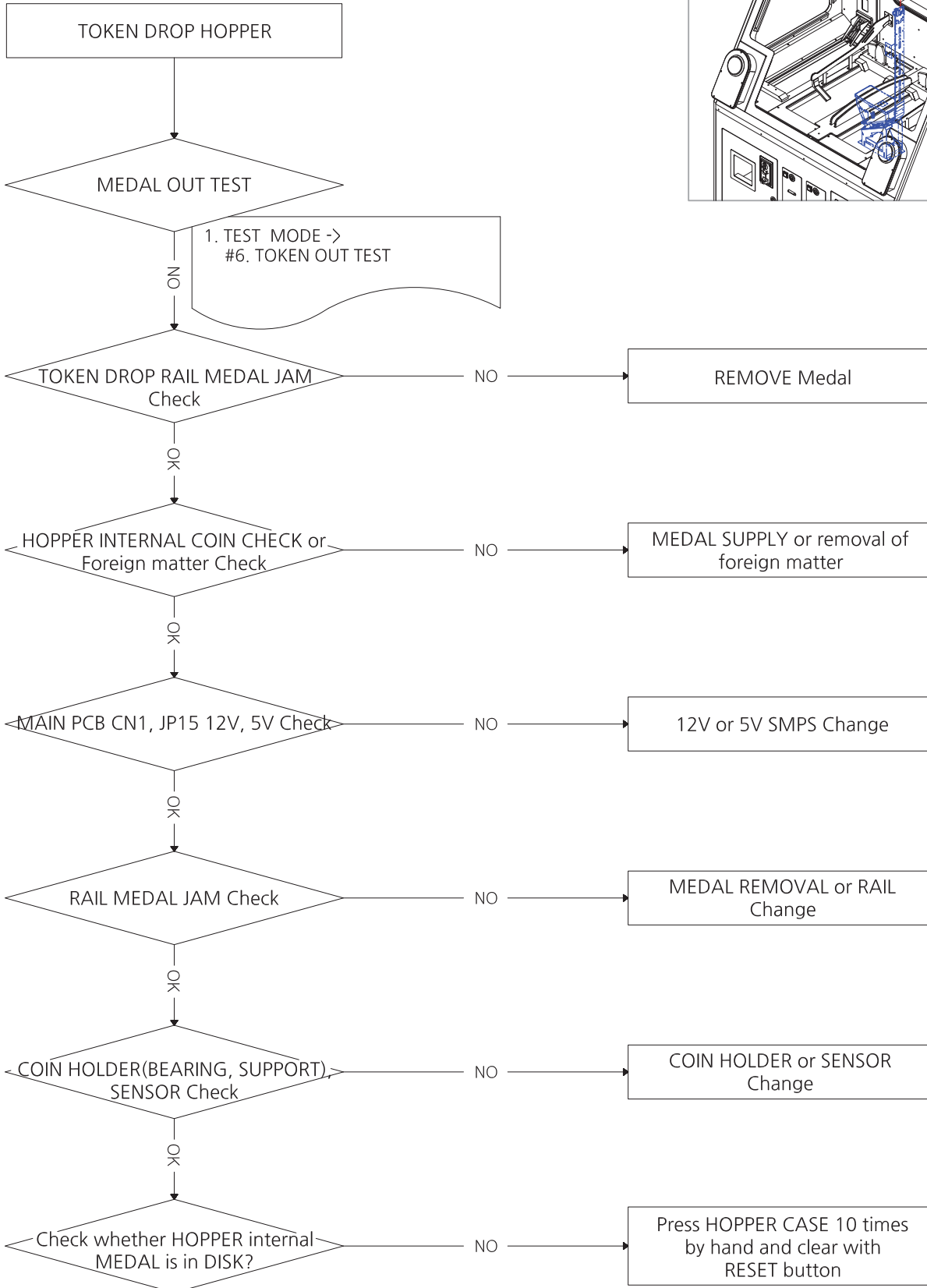
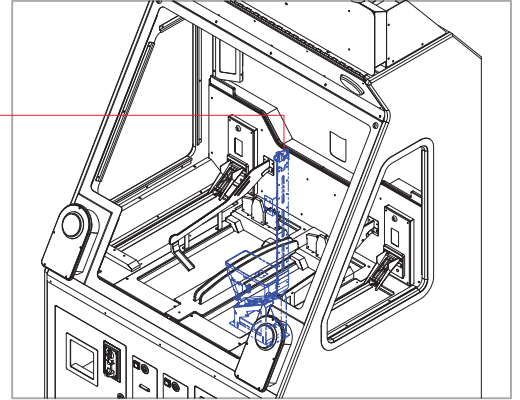

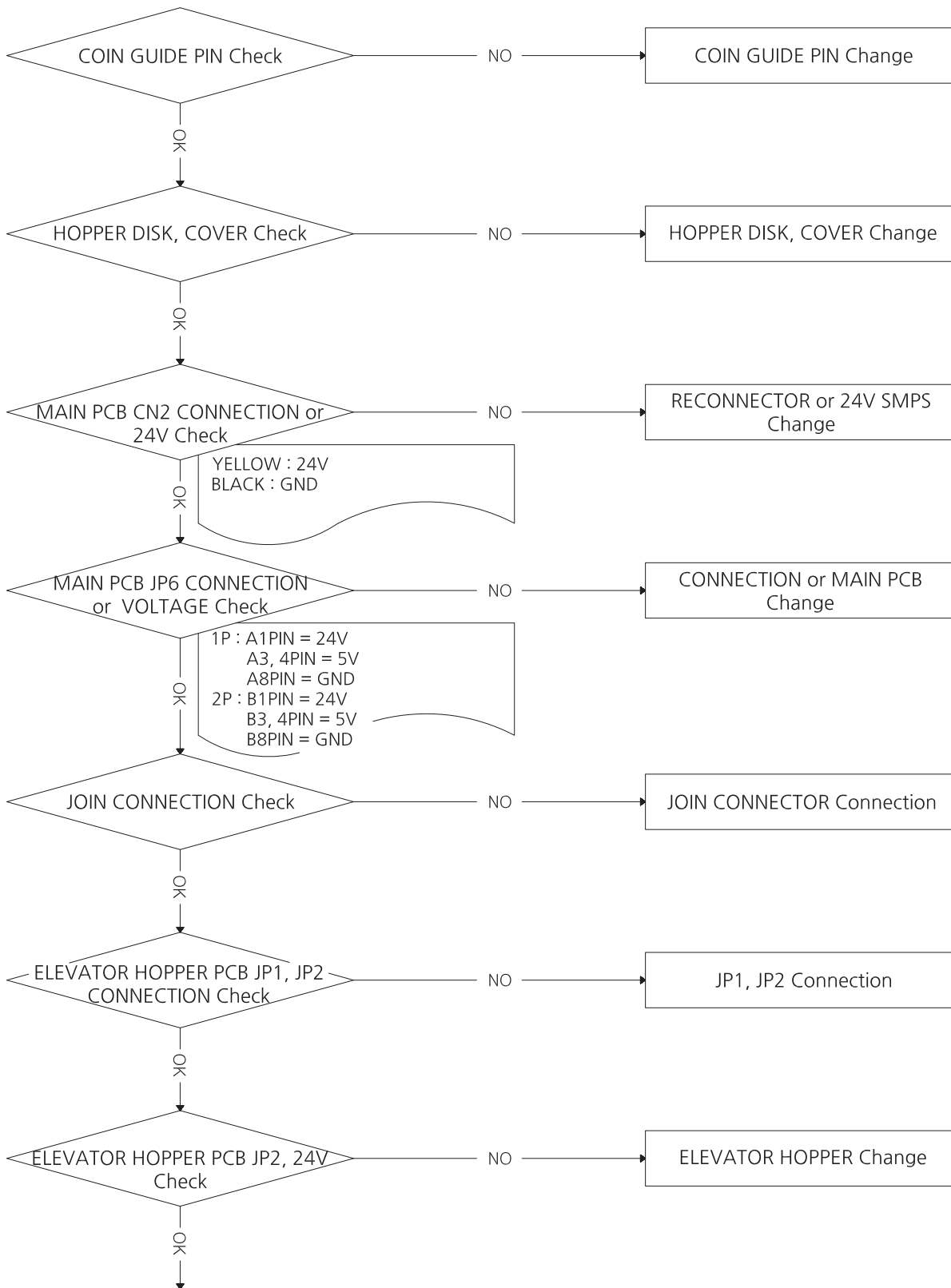

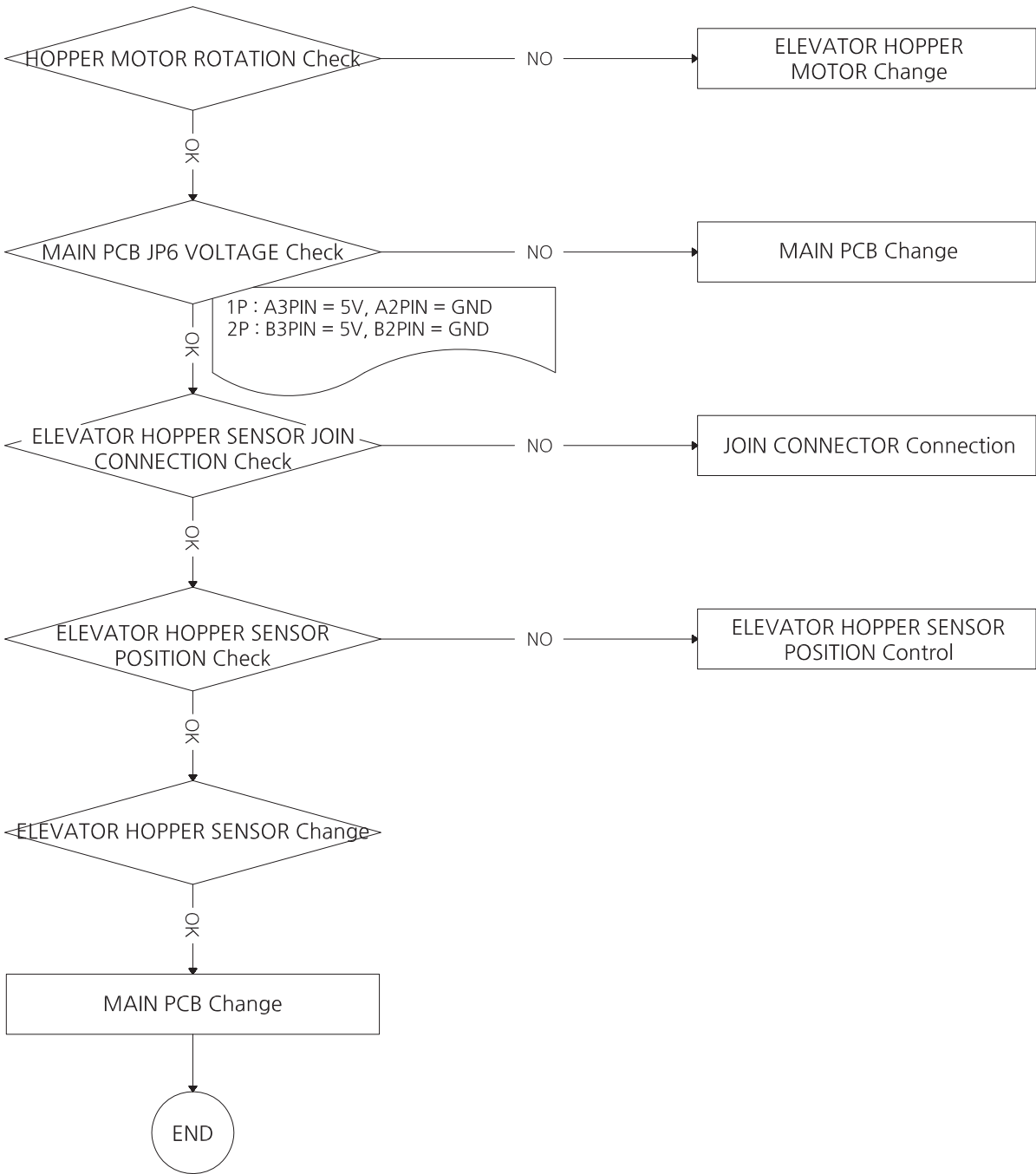

5-10. CARD DISPENSER ERROR [1~2P] - E.81 / E.82

CARD DISPENSER

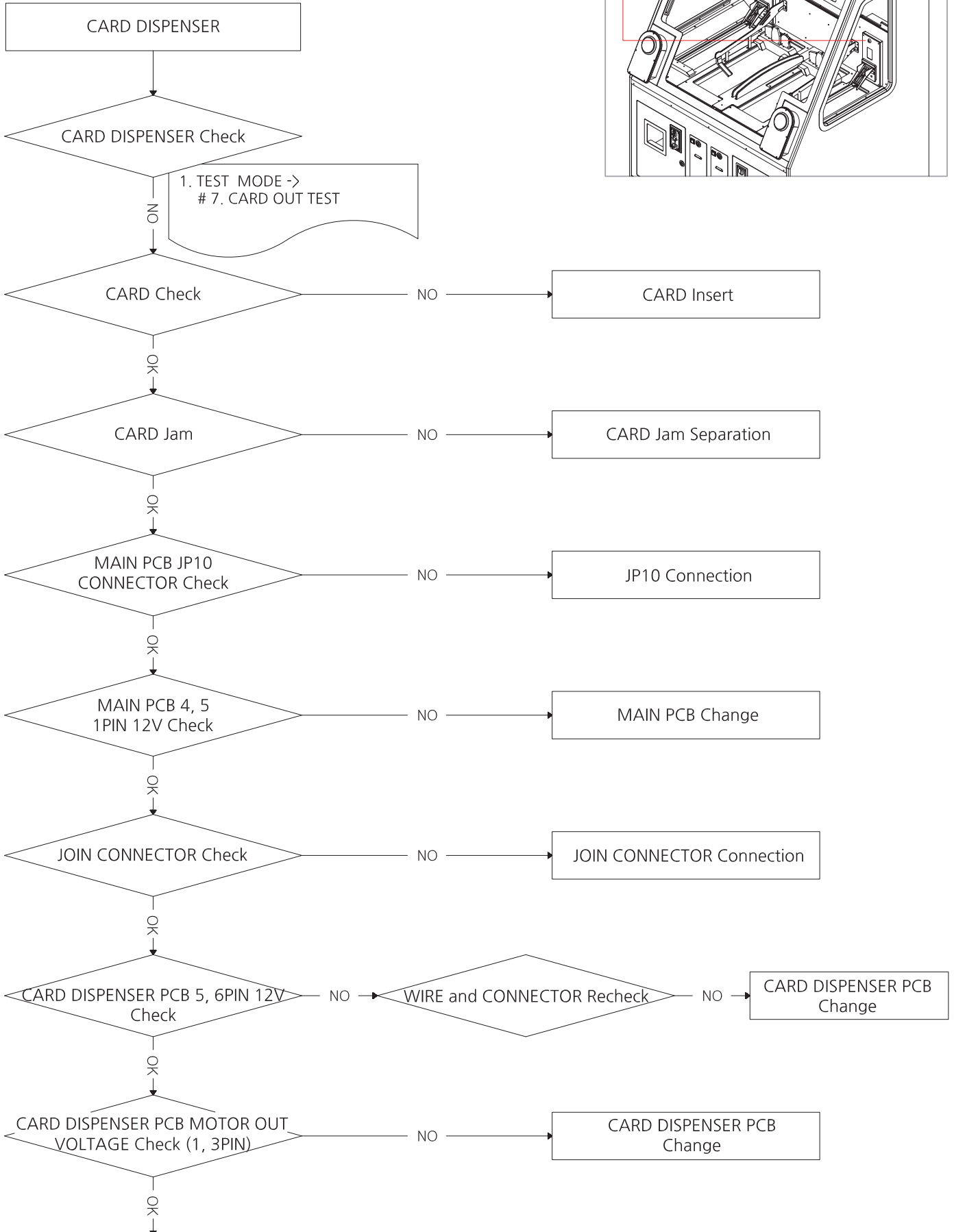
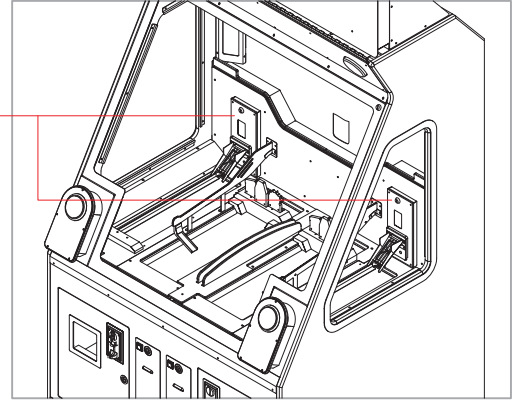

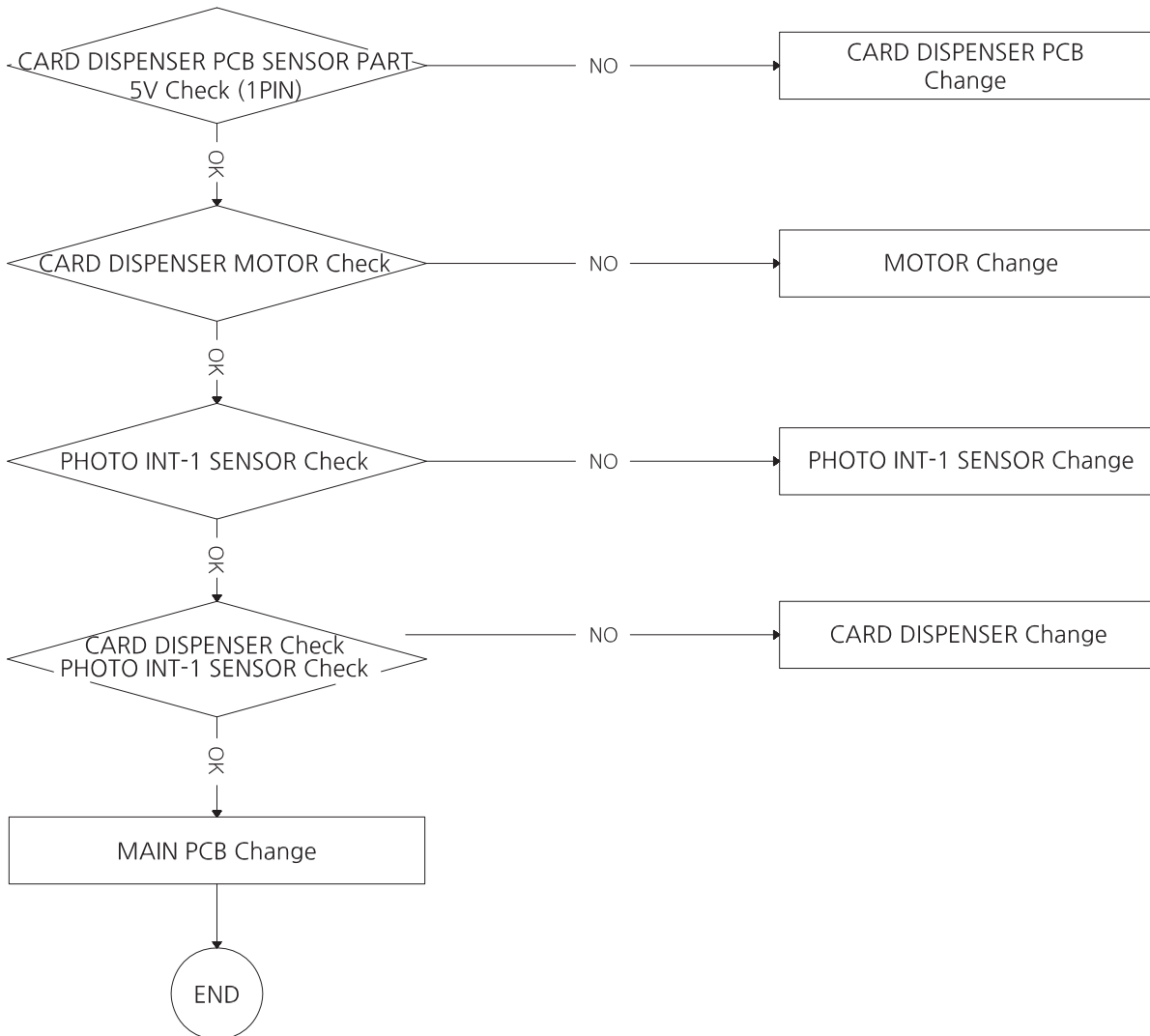

5-11. TICKET DISPENSER ERROR [E-t]

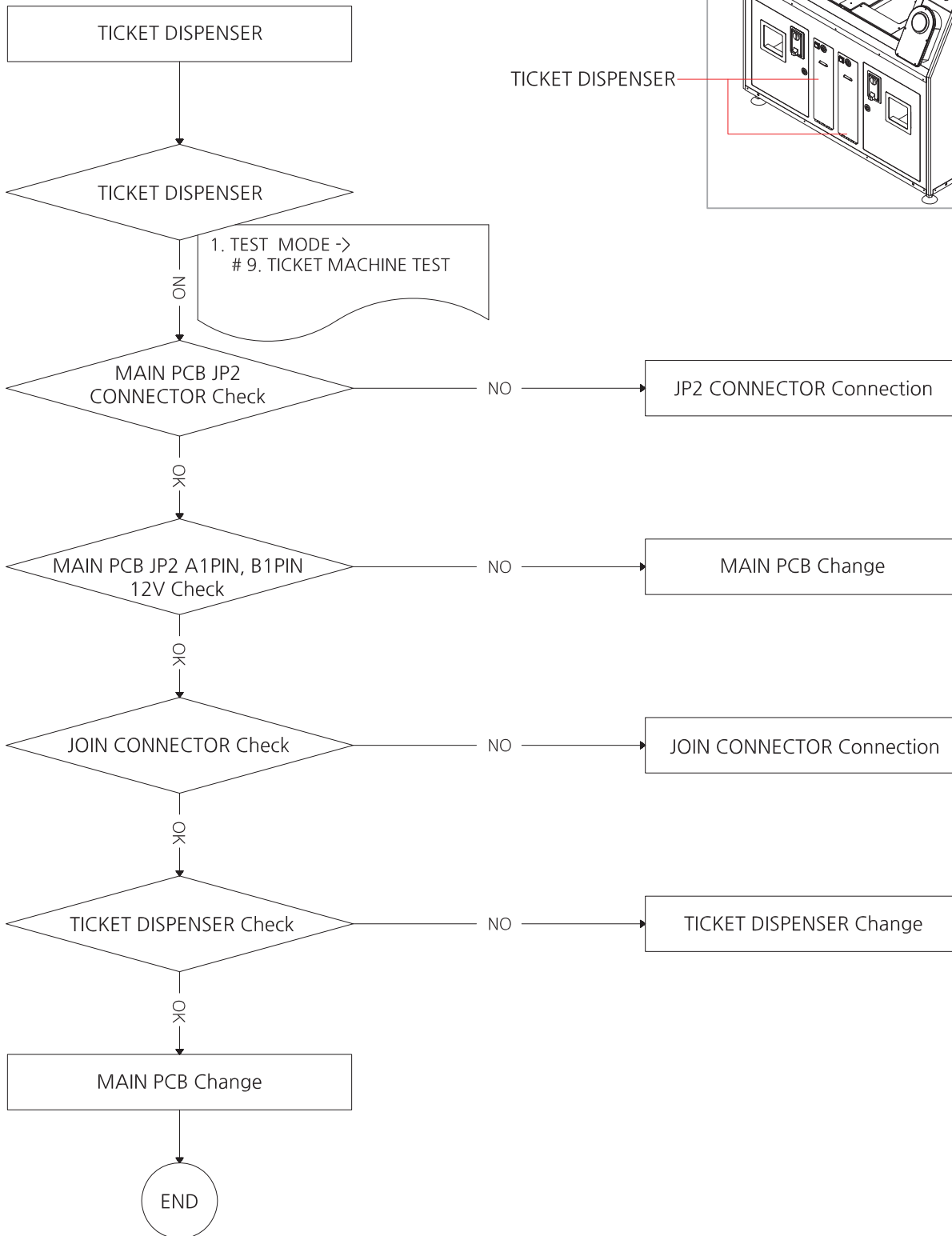

TICKET DISPENSER

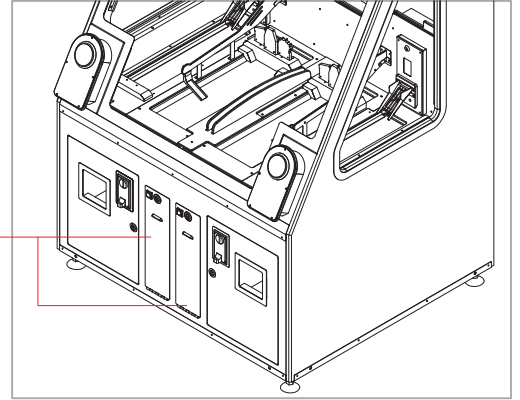

5-12. COUNTER ERROR

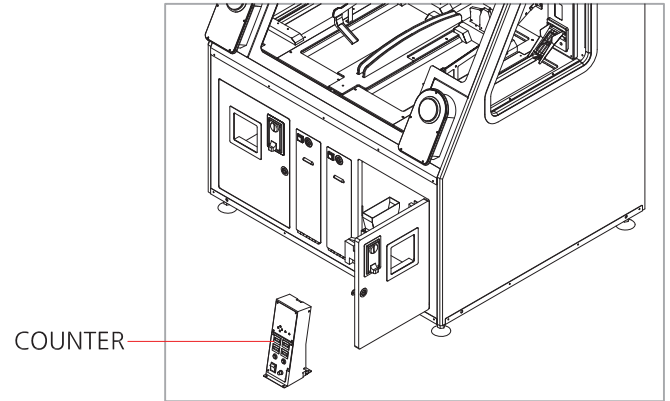
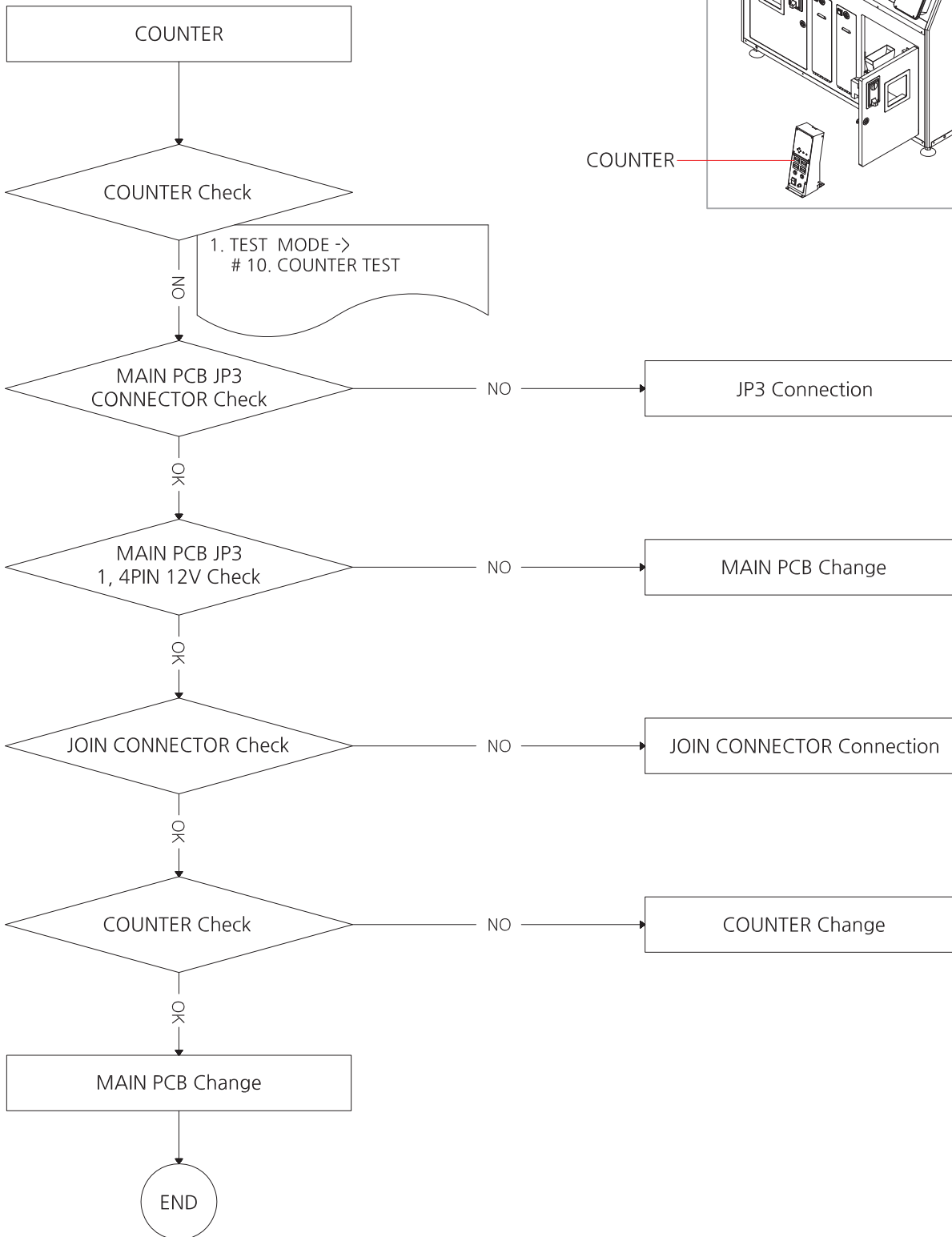

5-13. SOUND ERROR

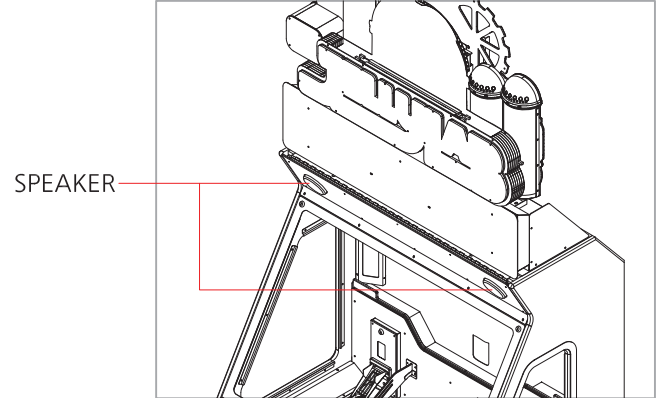
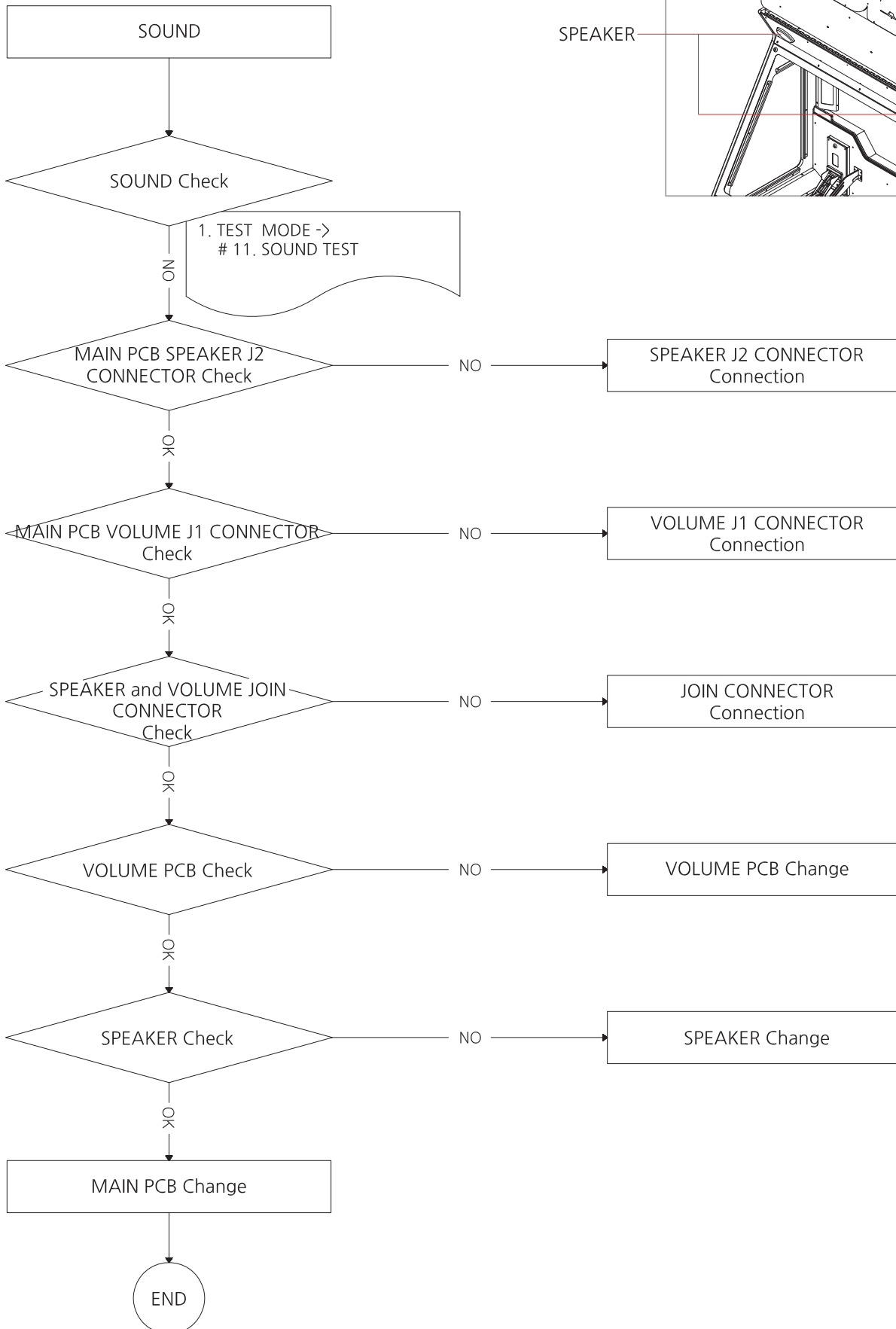

5-14. 2813B 16ea, 21ea When not lit (TOP BILLBOARD)

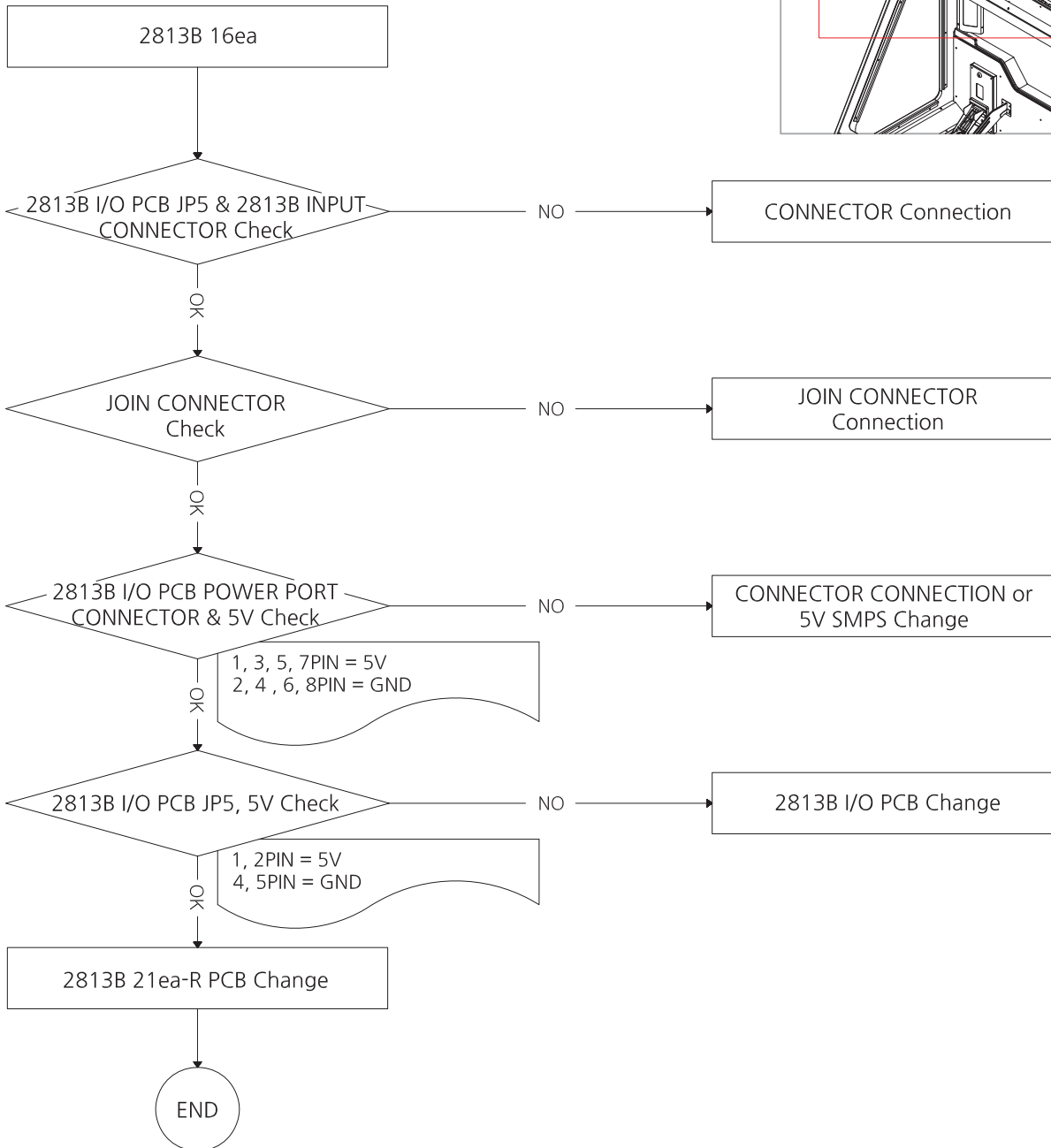
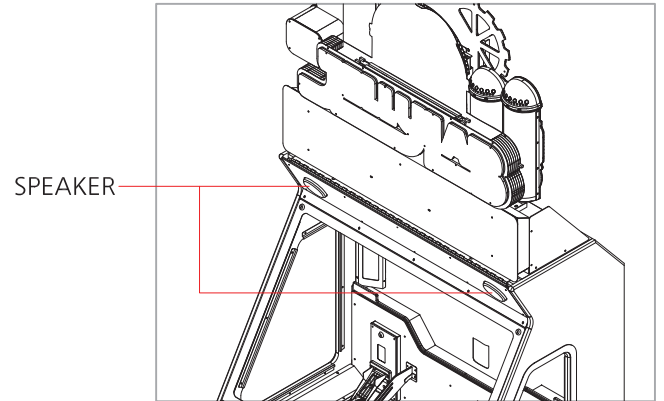

* If the middle LED PCB does not light up, check the front LED PCB connection status and check

5-15. 2813B 30ea, L When not lit (GAME PLATE MIDDLE)

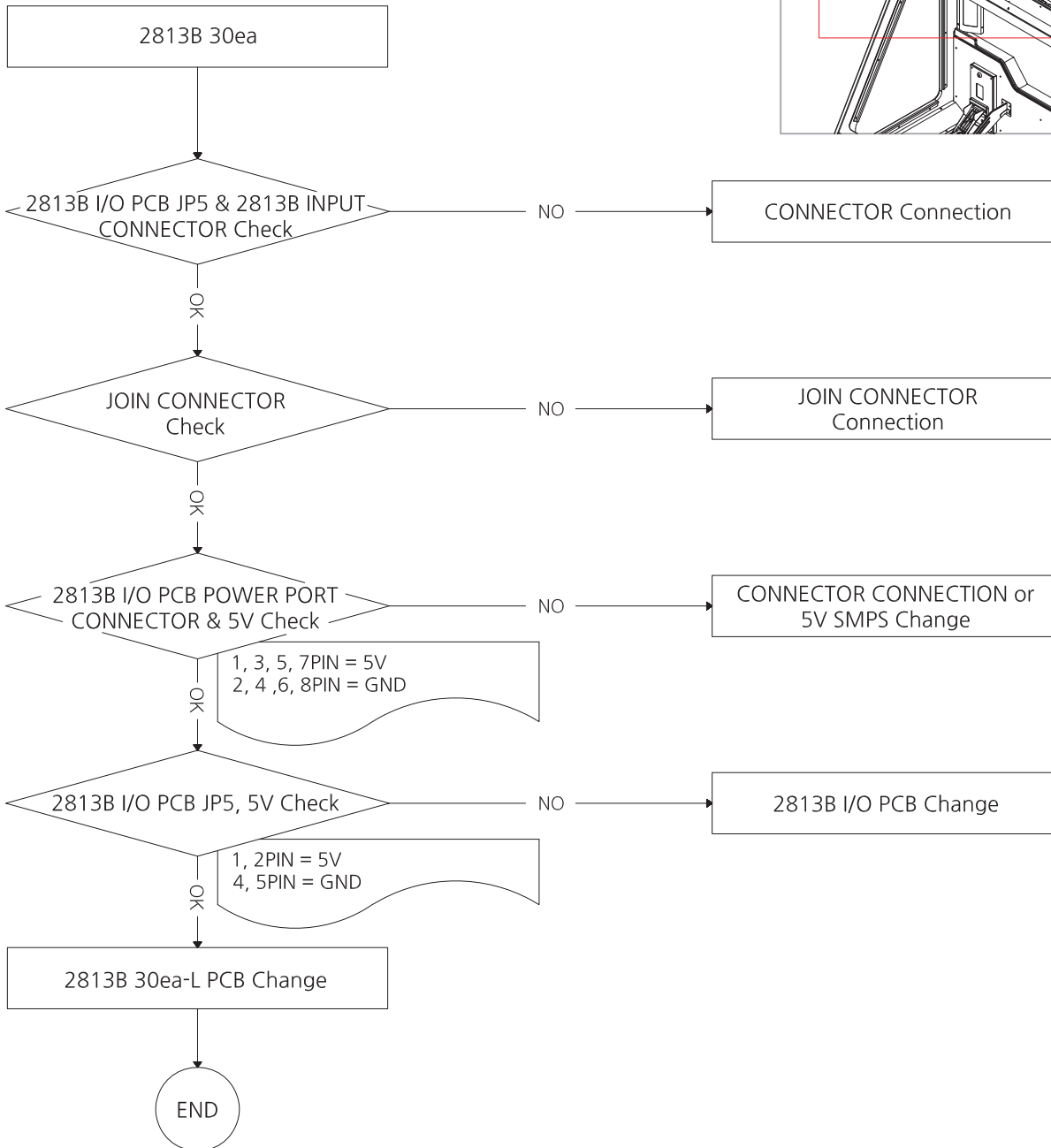
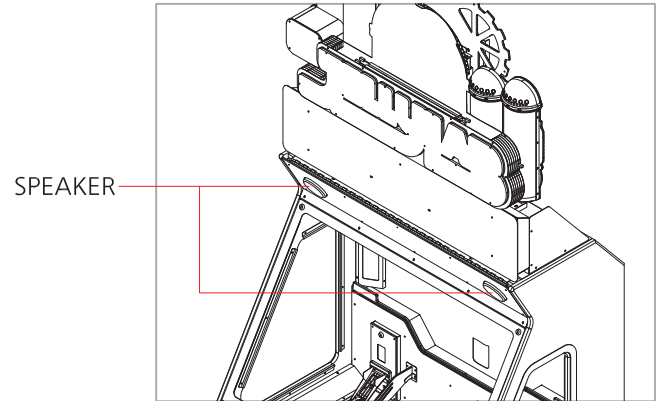

* If the middle LED PCB does not light up, check the front LED PCB connection status and check

5-16. 2813B FLEX or SIDE LIGHT When not lit

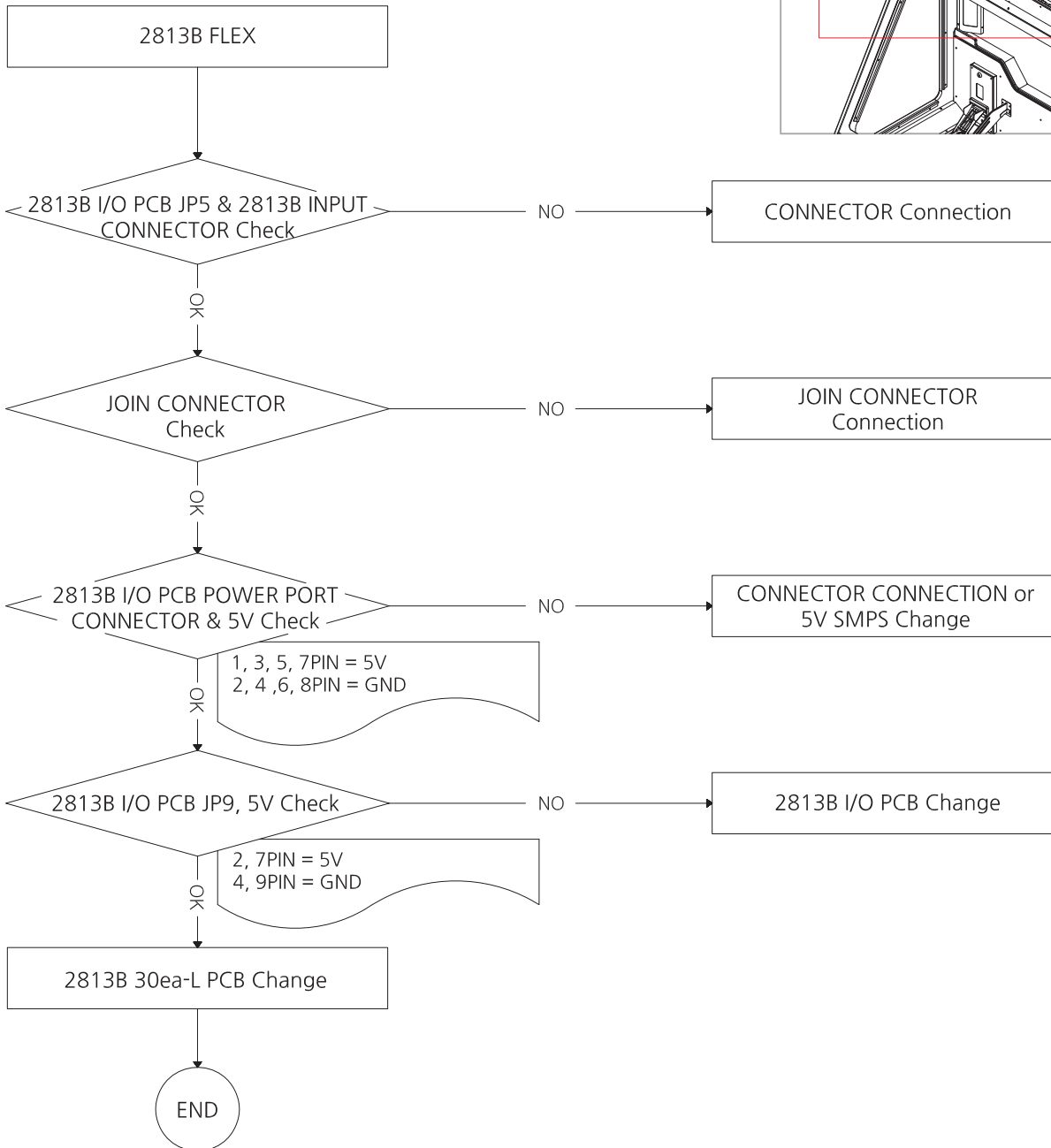
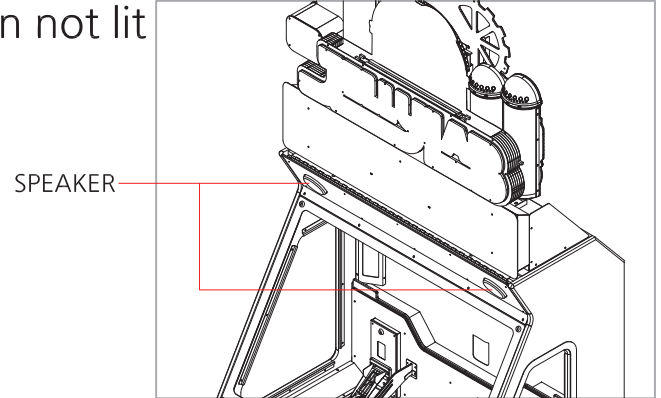

* If the middle LED PCB does not light up, check the front FLEX connection status and check

6. EXPLODED VIEW

6-1. MAIN CABINET PART

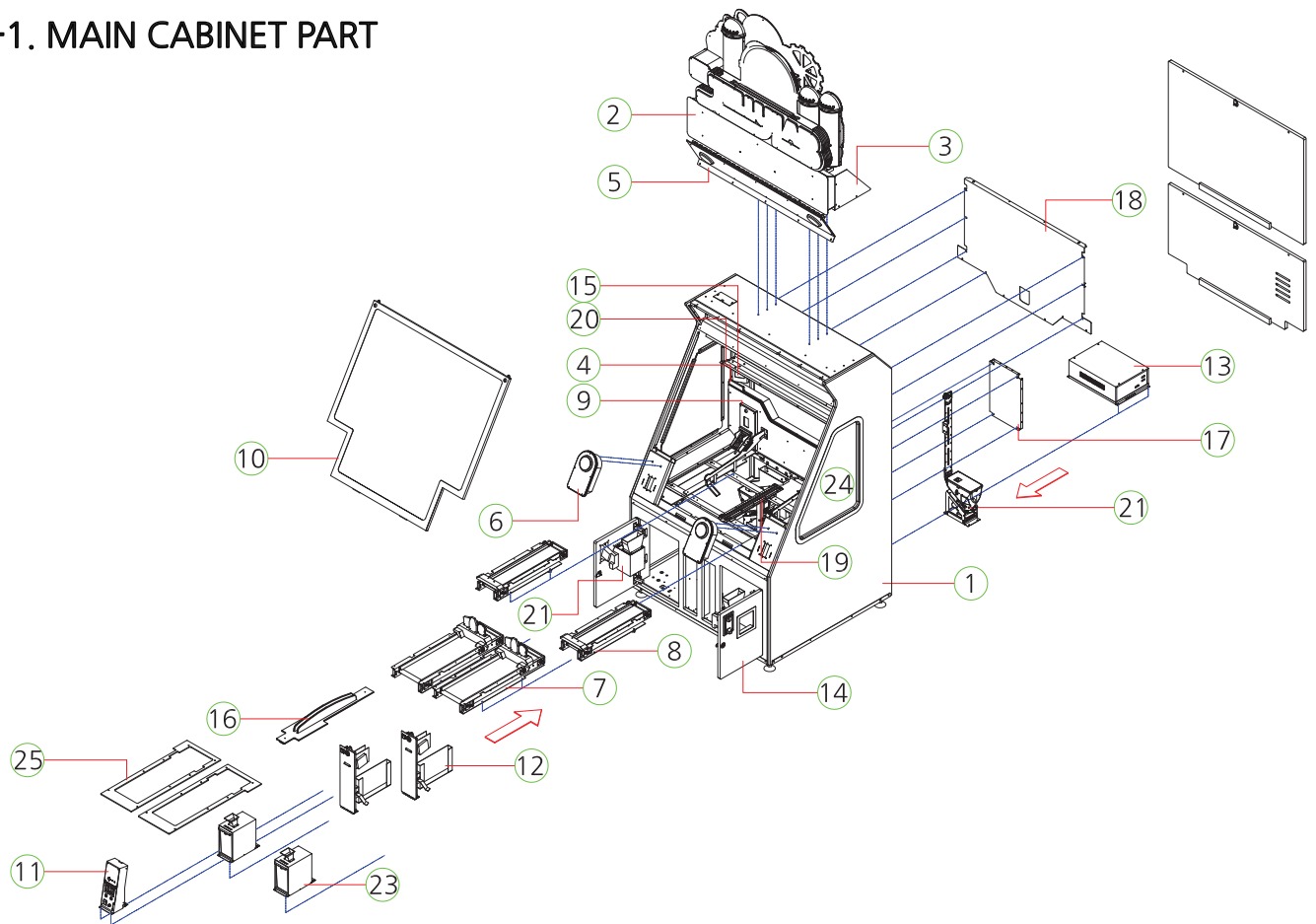

NO.	PART NAME	SPEC.	QUANTITY	CODE NO.
1	MAIN CABINET PART	-	1	-
2	TOP BILLBOARD PART	-	1	-
3	BILLBOARD MAIN PART	-	1	-
4	BACK BOARD PART	-	1	-
5	CABINET UPPER DISPLAY PART	-	1	-
6	BUTTON PLATE PART	-	2	-
7	COIN CONVEYOR PART	-	2	-
8	CARD CONVEYOR PART	-	2	-
9	CARD DISPENSER PART	-	1	-
10	FRONT UPPER DOOR PART	-	1	-
11	CONTROL PANEL PART	-	1	-
12	TICKET DOOR PART	-	2	-
13	SMPS PART	-	1	-
14	FRONT LOWER DOOR PART	-	2	-
15	REAR LIGHTING-L,R PART	-	2	-
16	GAME PLATE MIDDLE DISPLAY PART	-	1	-
17	MAIN BOARD PART	-	1	-
18	BACK BOARD REAR PART	-	1	-
19	GAME PLATE MIDDLE PCB PART	-	1	-
20	CABINET UPPER BAR LED PART	-	1	-
21	ELEVATOR HOPPER ASS'Y-L,R PART	-	2	-
22	CARD OUT CHUTE PART	-	2	-
23	COIN BOX COVER PART	-	2	-
24	SIDE WINDOW GLASS	GLASS-5.Ot	2	MDM30GLA001
25	COIN CONVEYOR COVER ACRYL-L, R	-	2	MDM30ACR029,030

6-2. TOP BILLBOARD PART

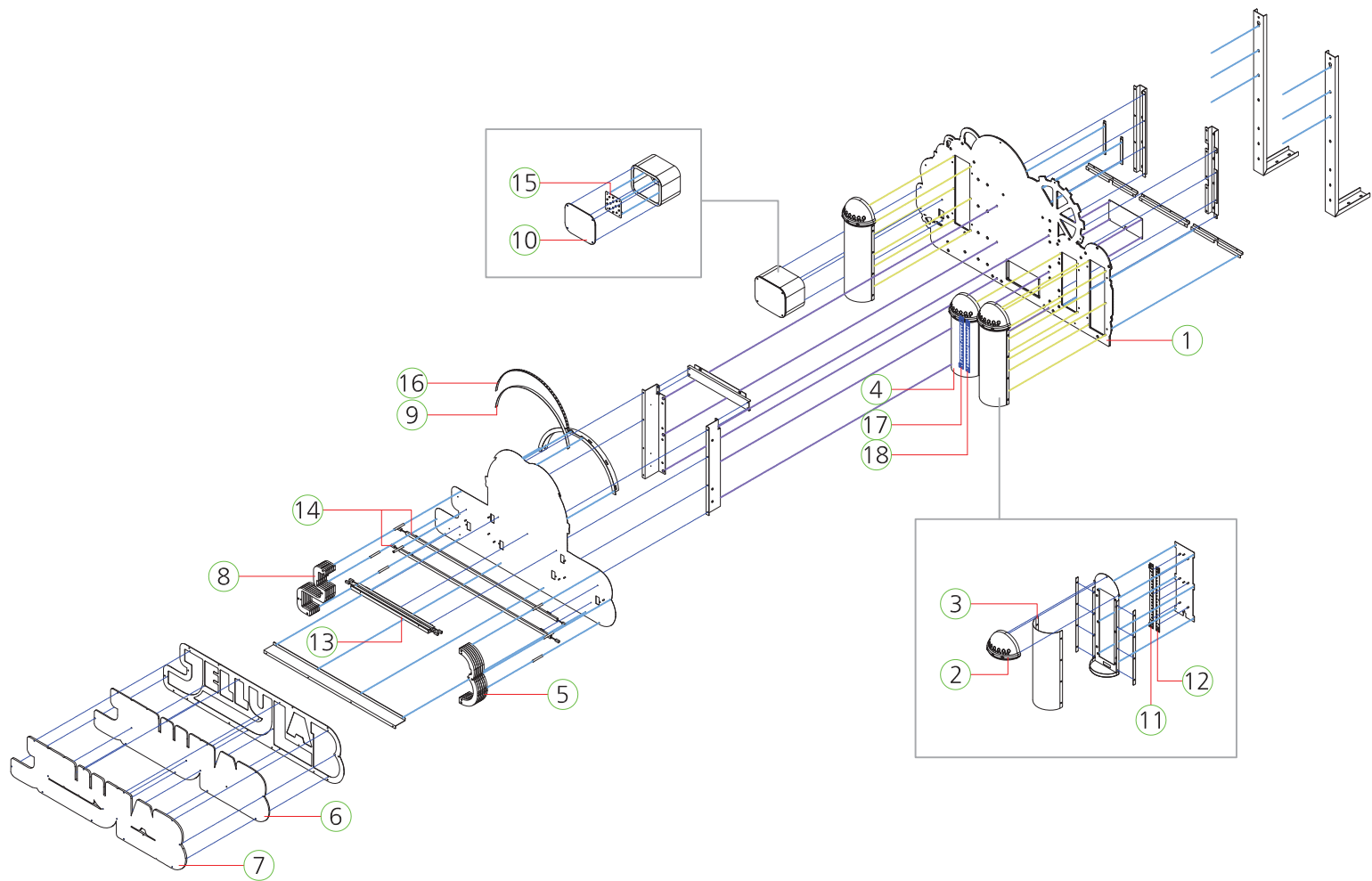

NO.	PART NAME	SPEC.	QUANTITY	CODE NO.
1	BILLBOARD FLASK REAR FOMAX	FOMAX-5.0t	1	MDM30ACR002
2	FLASK HEAD	ABS_BLACK	2	MDM3PLA001
3	FLASK COVER ACRYL-L	PET-1.0t	2	MDM30ACR012
4	FLASK COVER ACRYL-S	PET-1.0t	1	MDM30ACR013
5	BILLBOARD JELLY LAB SIDE COVER ACRYL-R	ACRYL-10.0t	6	MDM30ACR007
6	BILLBOARD JELLY LAB REAR ACRYL	ACRYL-5.0t	1	MDM30ACR005
7	BILLBOARD JELLY LAB ACRYL	ACRYL-8.0t	1	MDM30ACR004
8	BILLBOARD JELLY LAB SIDE COVER ACRYL-L	ACRYL-10.0t	6	MDM30ACR006
9	BILLBOARD MINIONS FLEXIBLE LED PCB ACRYL	PET-1.0t	1	MDM30ACR009
10	BILLBOARD DM COVER ACRYL	ACRYL-3.0t	1	MDM30ACR001
11	2813B-21EA L PCB ASS'Y	-	2	APLX0PCB004
12	2813B-21EA R PCB ASS'Y	-	2	APLX0PCB008
13	12V_LED BAR PCB ASS'Y	460mm	2	AZZZ0PCB124
14	12V_LED BAR PCB ASS'Y	1000mm	2	-
15	BILLBOARD MINIONS FLEXIBLE LED PCB ASS'Y	SMD3528 60PCS GREEN	1	-
16	OUT LED PCB ASS'Y	WHITE	1	ABAP0PCB003
17	2813B-16EA L PCB ASS'Y	-	1	APLX0PCB003
18	2813B-16EA R PCB ASS'Y	-	1	APLX0PCB007

6-3. BILLBOARD MAIN PART

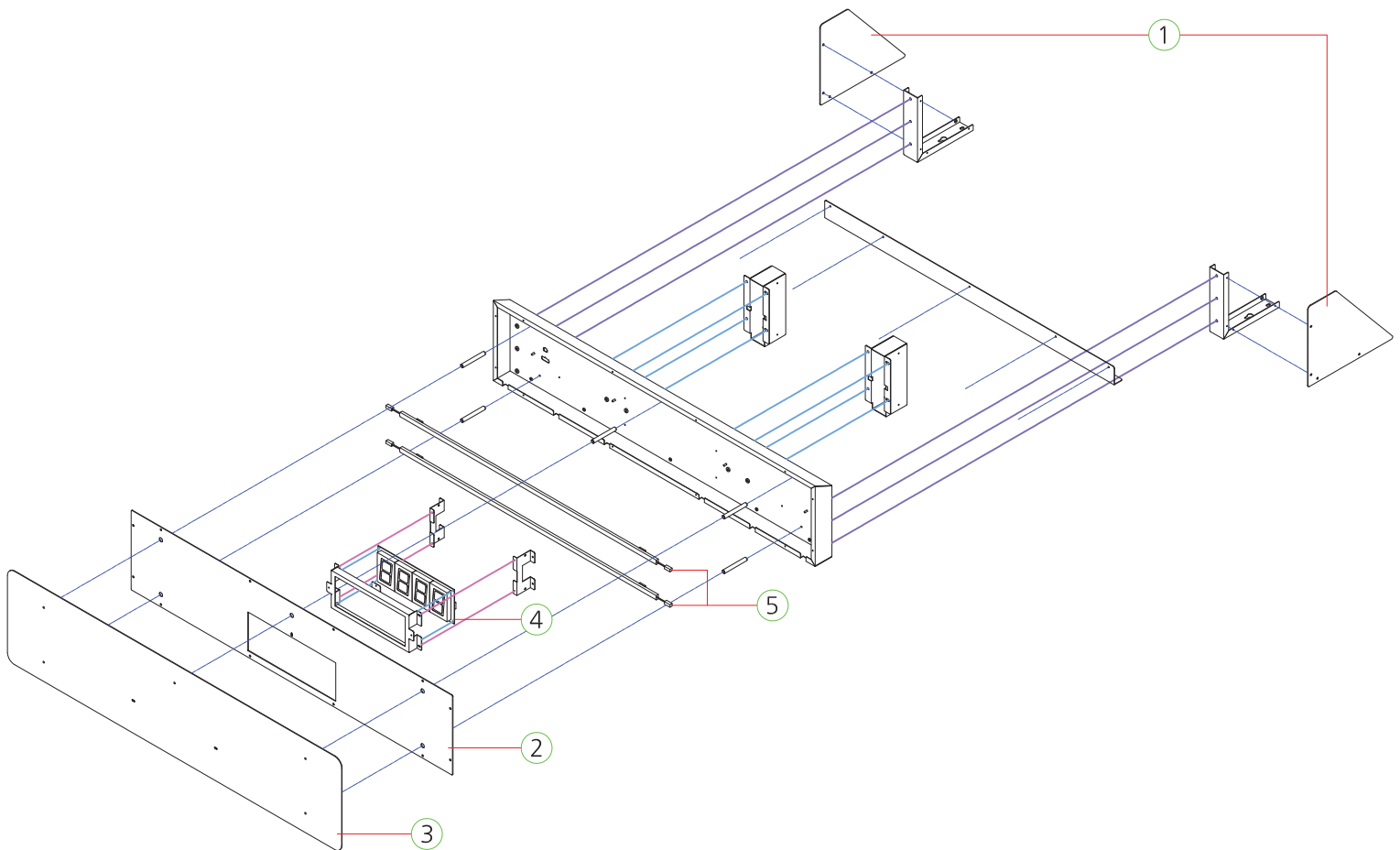

NO.	PART NAME	SPEC.	QUANTITY	CODE NO.
1	BILLBOARD SIDE ACRYL-L,R	PET-2.0t	1	MDM30ACR010, 011
2	BILLBOARD MAIN COVER ACRYL	PET-2.0t	1	MDM30ACR008
3	BILLBOARD FRONT ACRYL	PET-2.0t	1	MDM30ACR003
4	FND PCB ASS'Y	6390-4(STRAIGHT)	1	AFND0PCB011
5	12V_LED BAR PCB ASS'Y	960mm	2	AZZZ0PCB128

6-4. BACK BOARD PART

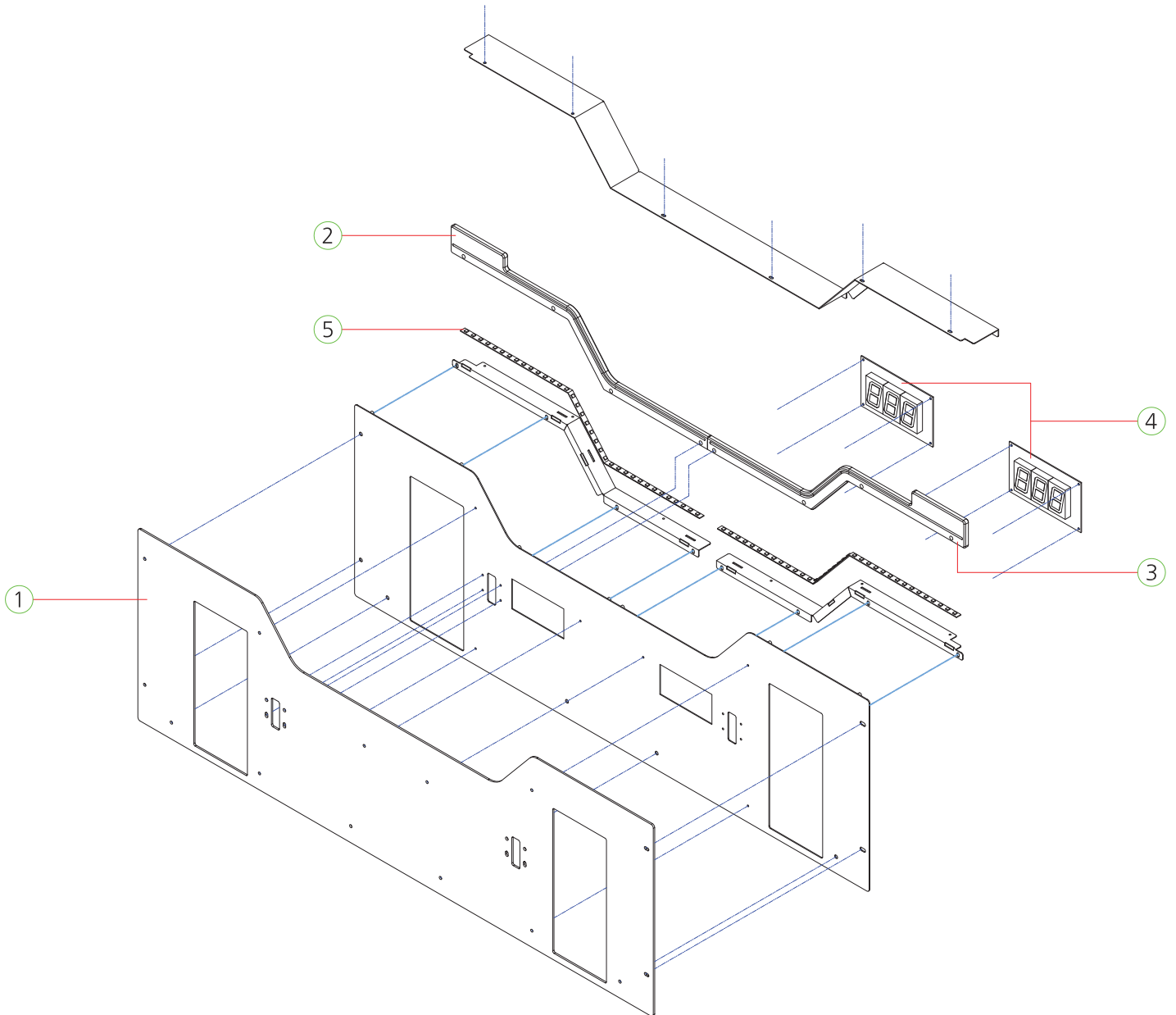

NO.	PART NAME	SPEC.	QUANTITY	CODE NO.
1	BACK BOARD ACRYL	ACRYL-3.0t	2	MDM30ACR014
2	BACK BOARD SIDE ACRYL-L	ACRYL-10.0t	1	MDM30ACR015
3	BACK BOARD SIDE ACRYL-R	ACRYL-10.0t	1	MDM30ACR016
4	BONUS FND PCB ASS'Y	SND1817-3	2	ASBP0PCB003
5	WS 2813B FLEXIBLE LED ASS'Y	-	2	-

6-5. CABINET UPPER DISPLAY PART

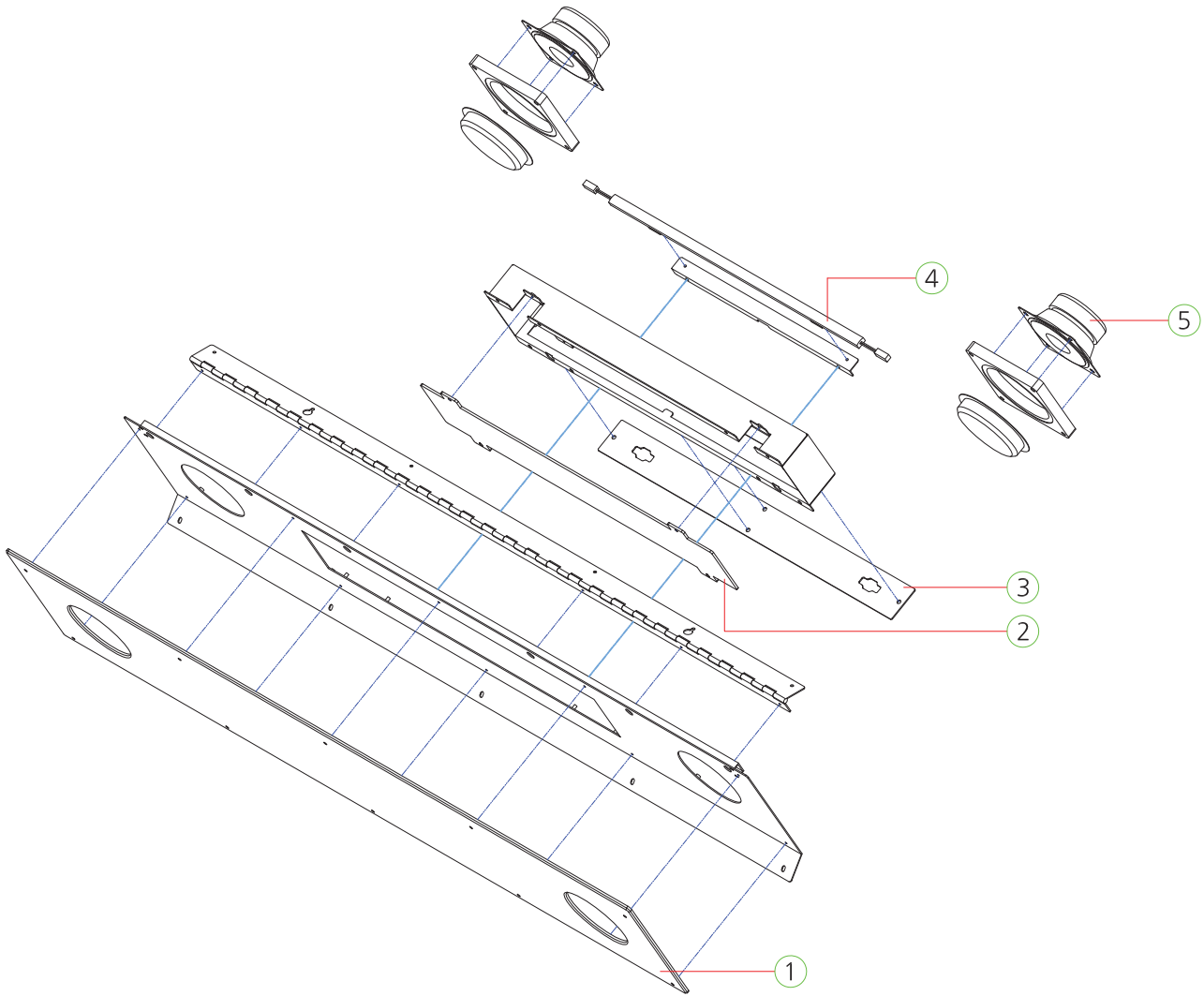

NO.	PART NAME	SPEC.	QUANTITY	CODE NO.
1	CABINET UPPER DISPLAY ACRYL	ACRYL-5.0t	1	MDM30ACR023
2	CARD DISPLAY ACRYL	ACRYL-3.0t	1	MDM30ACR026
3	CABINET DISPLAY LOWER ACRYL	PET-2.0t	1	MDM30ACR027
4	12V_LED BAR PCB ASS'Y	460mm	1	AZZZ0PCB124
5	SPEAKER	MID4.5+TW1/2" 8Ω"	2	MZZZ0SPE021

6-6. BUTTON PLATE PART

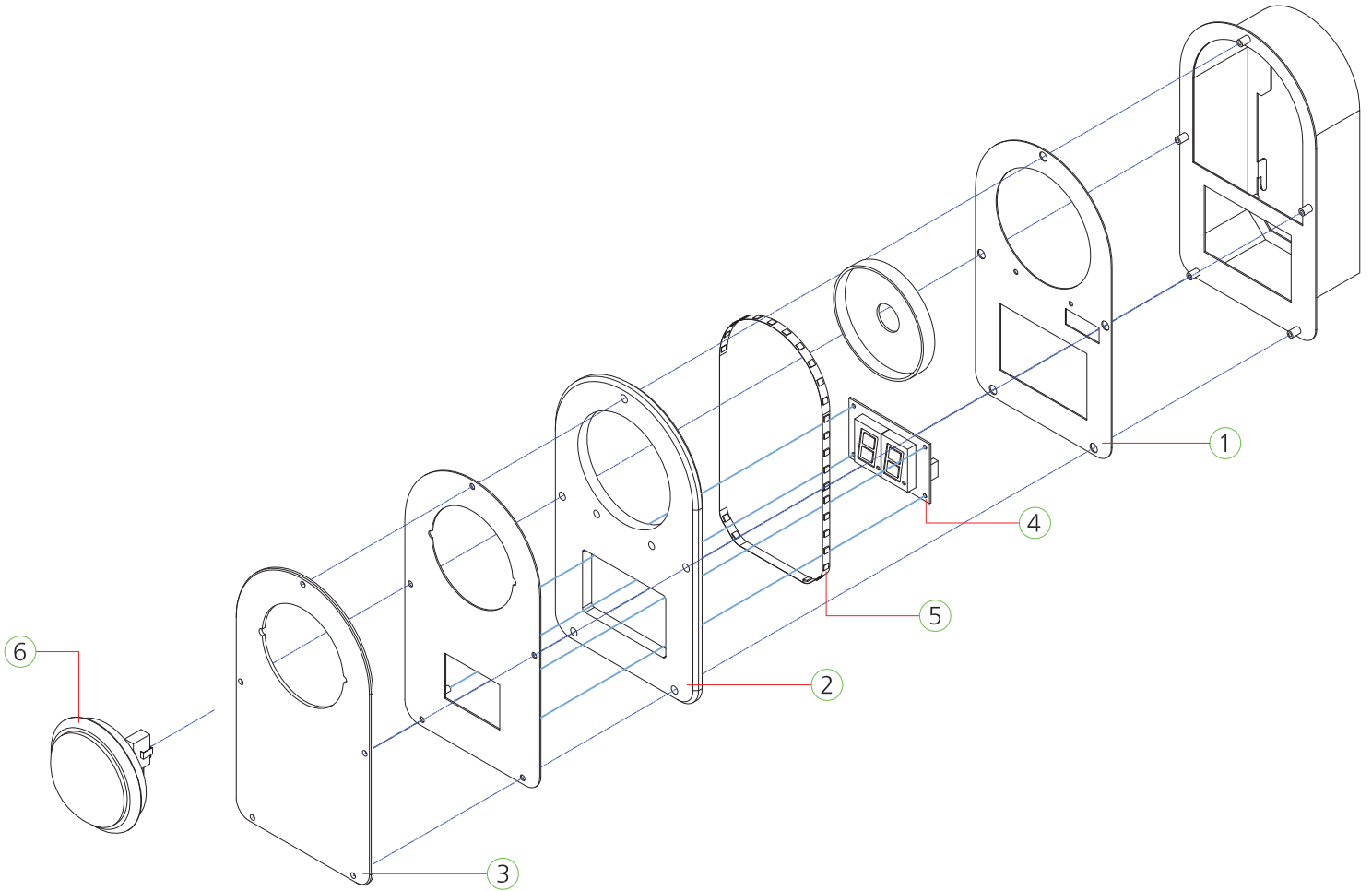

NO.	PART NAME	SPEC.	QUANTITY	CODE NO.
1	BUTTON LED PCB COVER ACRYL	PET-1.0t	1	MDM30ACR020
2	BUTTON ACRYL	ACRYL-10.0t	1	MDM30ACR018
3	BUTTON FRONT COVER ACRYL	ACRYL-3.0t	1	MDM30ACR019
4	FND PCB ASS'Y	2941-2(STRAIGHT)	1	AFND0PCB003
5	BUTTON FLEXIBLE LED ASS'Y	GREEN	1	-
6	BUTTON ASS'Y	CWB 401-WHITE COLOR (Ø100 DOME)_LED TYPE	1	MZZZ0BUT080

6-7. COIN CONVEYOR PART

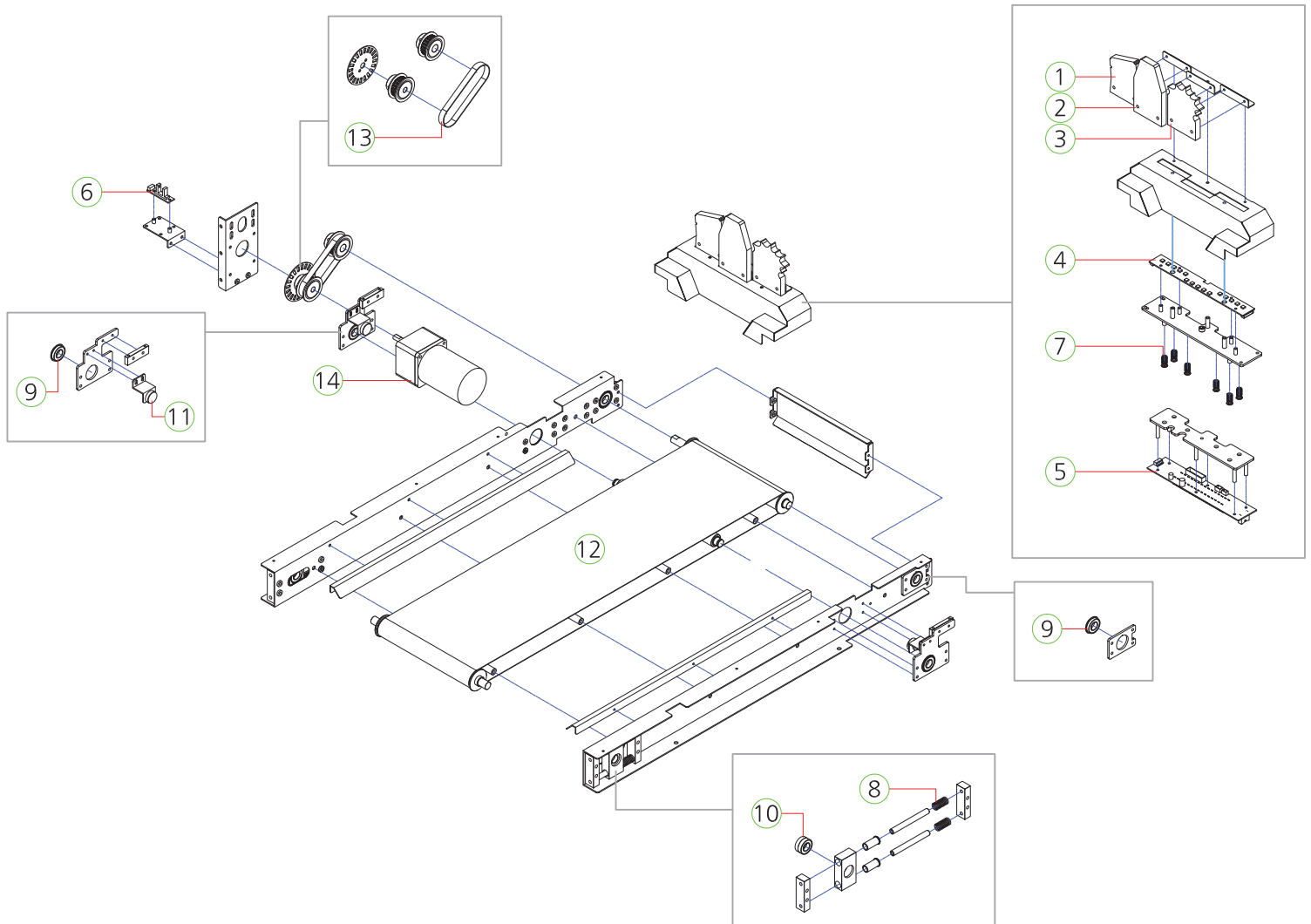

NO.	PART NAME	SPEC.	QUANTITY	CODE NO.
1	COIN CONVEYOR TICKET ACRYL	ACRYL-10.0t	1	MDM30ACR038
2	COIN CONVEYOR CARD ACRYL	ACRYL-10.0t	1	MDM30ACR037
3	COIN CONVEYOR TRY AGAIN ACRYL	ACRYL-10.0t	1	MDM30ACR039
4	COIN CHECK LED PCB ASS'Y	-	1	-
5	NEW COIN CHECK SENSOR PCB ASS'Y	-	1	ADM30PCB007
6	PHOTO INT1 PCB ASS'Y	ANGLE TYPE	1	AZZZ0PCB103
7	COIN CHECK SENSOR SPRING	SUS304-Ø0.7	6	MDM30SPR002
8	CONVEYOR TENSION SPRING	SUS304-Ø1.2	2	MDM30SPR001
9	BEARING	6901ZZNR	4	MZZZ0BEA111
10	BEARING	6901ZZ	4	MZZZ0BEA112
11	BEARING	DR19-B	1	MZZZ0BEA117
12	COIN CONVEYOR BELT	URETHANE-0.8t_WHITE	1	ADM30ASS002
13	CONVEYOR TIMMING BELT	100XL-037	1	MZZZ0BEL036
14	DC MOTOR	K6DG15N1 + K6G60C	1	MZZZ0MOT116

6-8. CARD CONVEYOR PART

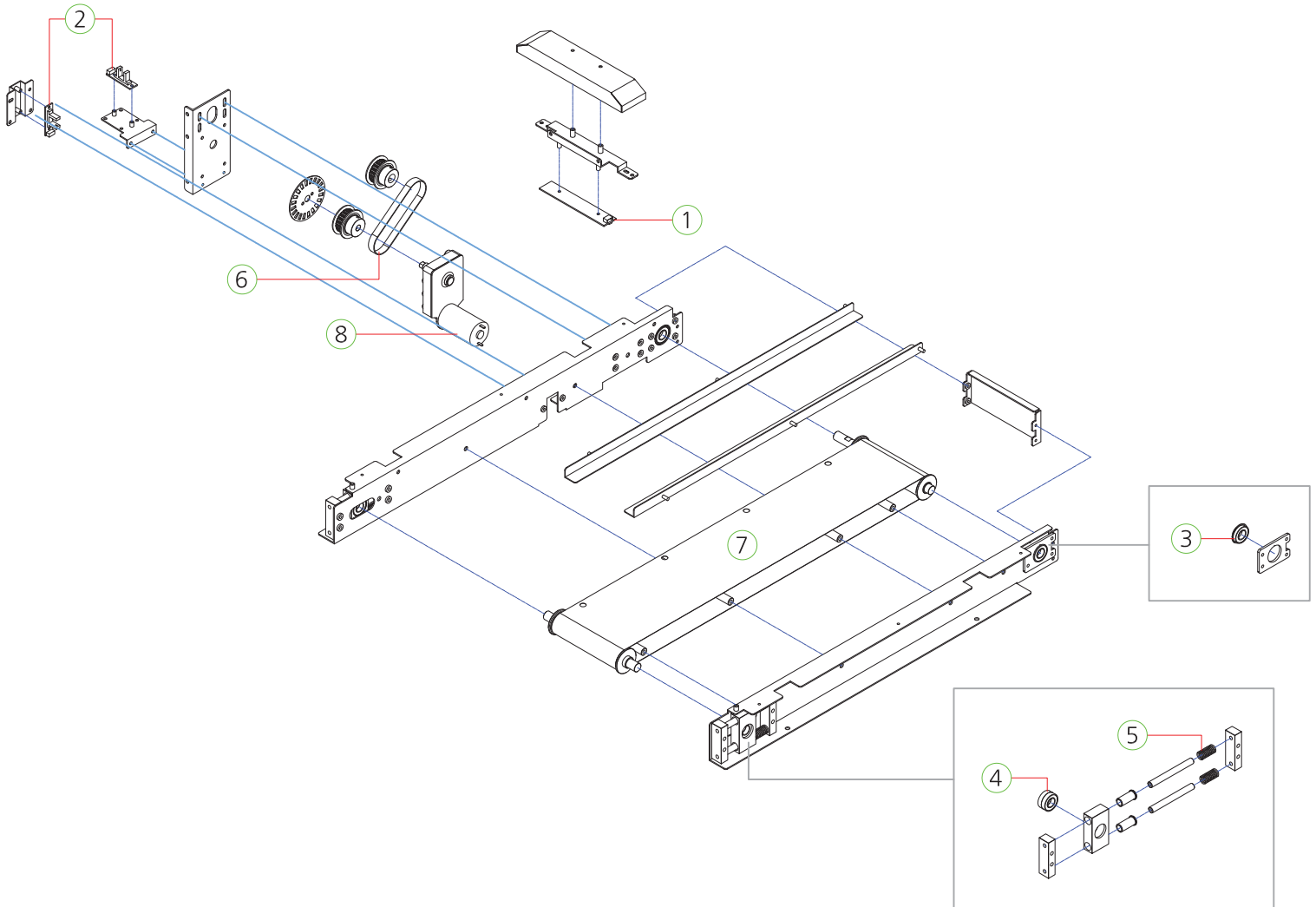

NO.	PART NAME	SPEC.	QUANTITY	CODE NO.
1	CARD SENSOR PCB ASS'Y	DM3	1	ADM30PCB003
2	PHOTO INT1 PCB ASS'Y	ANGLE TYPE	2	AZZZ0PCB103
3	BEARING	6901ZZNR	2	MZZZ0BEA111
4	BEARING	6901ZZ	4	MZZZ0BEA112
5	CONVEYOR TENSION SPRING	SUS304-Ø1.2	1	MDM30SPR001
6	CONVEYOR TIMMING BELT	100XL-037	1	MZZZ0BEL036
7	CARD CONVEYOR BELT	URETHANE-0.8t_WHITE	1	MDM30ASS003
8	MOTOR	KGE-0182-ND3657U1 (12V,27rpm)	1	MZZZ0MOT115

6-9. CARD DISPENSER PART

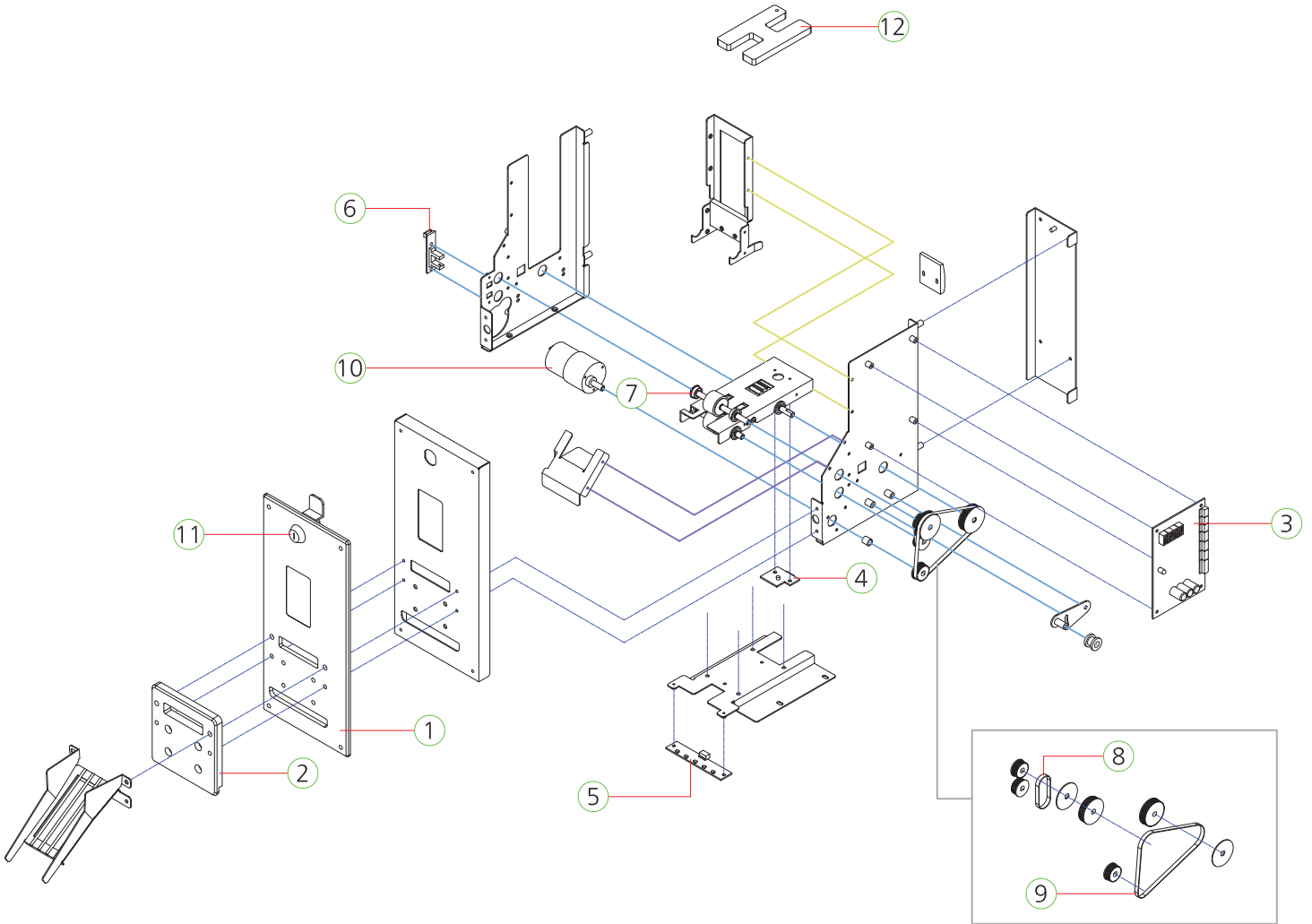

NO.	PART NAME	SPEC.	QUANTITY	CODE NO.
1	CARD DISPENSER FRONT COVER ACRYL	-	1	MDM30ACR041
2	CARD DISPENSER FRONT MASK	-	1	MDM30ACR040
3	CARD DISPENSER IO PCB ASS'Y	-	1	ASBP0PCB008
4	CARD IR SENSOR PCB ASS'Y	-	1	-
5	LED PCB ASS'Y	-	1	AMUM0PCB005
6	PHOTO INT1 PCB ASS'Y_ANGLE	-	1	AZZZ0PCB103
7	BEARING	F686ZZ	1	MZZZ0BEA094
8	TIMMING BELT-A	52MXL, W4.8	1	MZZZ0BEL018
9	TIMMING BELT-B	147MXL, W4.8	1	MZZZ0BEL019
10	DC MOTOR	KGC-040-3429C	1	MZZZ0MOT089
11	KEY ASS'Y	7001	1	MZZZ0KEY076
12	CARD HEAVY PUSH BKT	-	1	MSBP0MEP023

6-10. FRONT UPPER DOOR PART

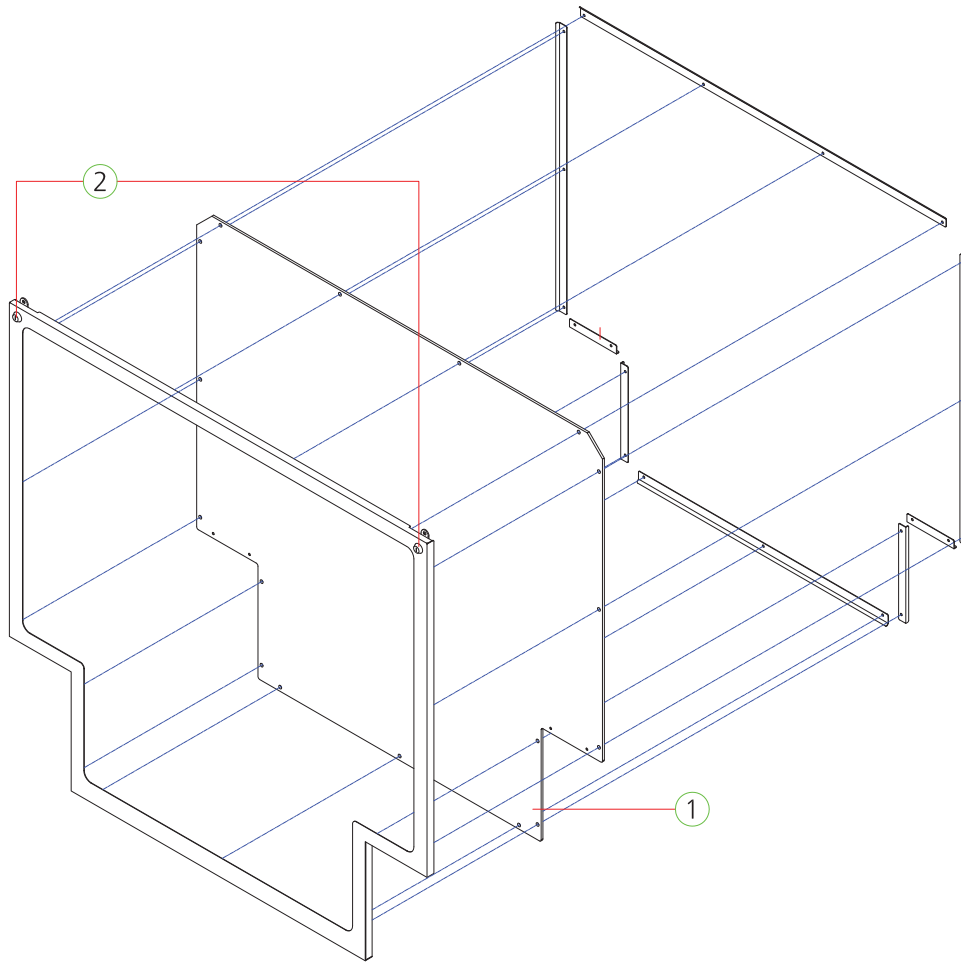

NO.	PART NAME	SPEC.	QUANTITY	CODE NO.
1	FRONT UPPER DOOR ACRYL	PC-5.0t	1	MDM30ACR032
2	KEY ASS'Y	7001	2	MZZZ0KEY076

6-11. SETUP PANEL PART

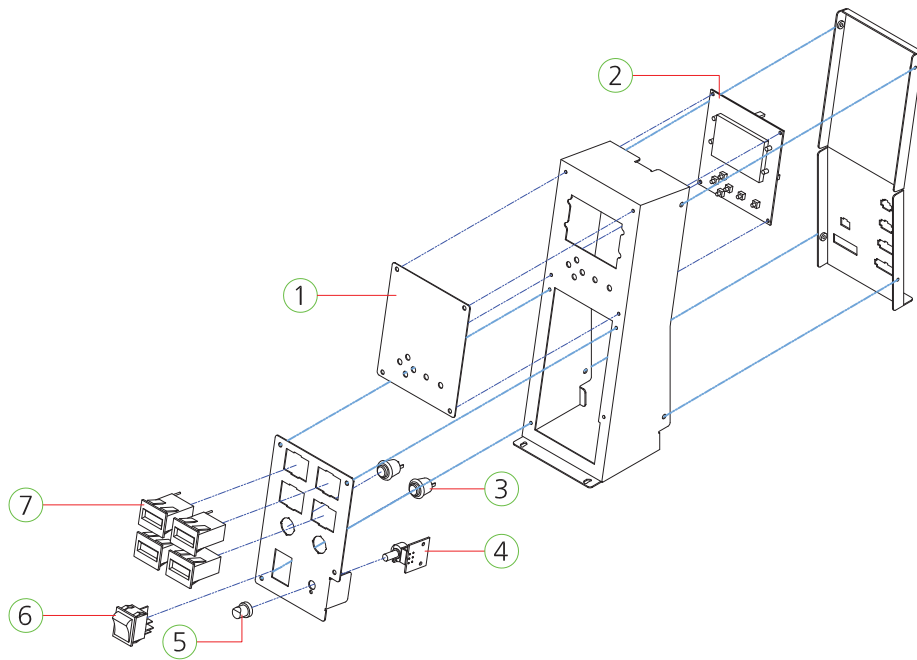

NO.	PART NAME	SPEC.	QUANTITY	CODE NO.
1	CONTROL PANEL COVER ACRYL	PET-1.0t	1	MDM30ACR031
2	SETUP LCD PCB ASS'Y	-	1	AZZZ0PCB113
3	PUSH BUTTON SWITCH	HS 412R	2	MELE0PUS001
4	VOLUME PCB ASS'Y	-	1	AHM20PCB016
5	VOLUME KNOB	-	1	MELE0VOL007
6	ROCKER SWITCH	T-125 4P	1	MELE0SWI004
7	COUNTER	OA127CL	4	MZZZ0COU002

6-12. TICKET DOOR PART

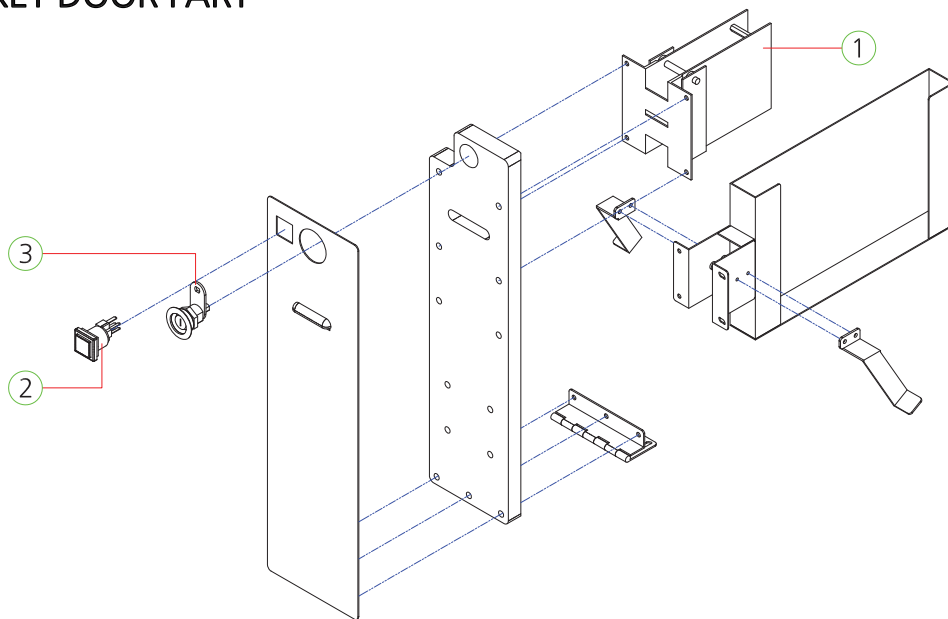

NO.	PART NAME	SPEC.	QUANTITY	CODE NO.
1	TICKET DISPENSER	CLE CL-002Q_270	1	MZZZ0TID010
	or TICKET DISPENSER	DL-1275	1	MZZZ0TID008
2	BUTTON SWITCH	AM1PB-26SH R12D	1	MMUM0BUT002
3	KEY ASS'Y	7001	1	MZZZ0KEY076

6-13. SMPS PART

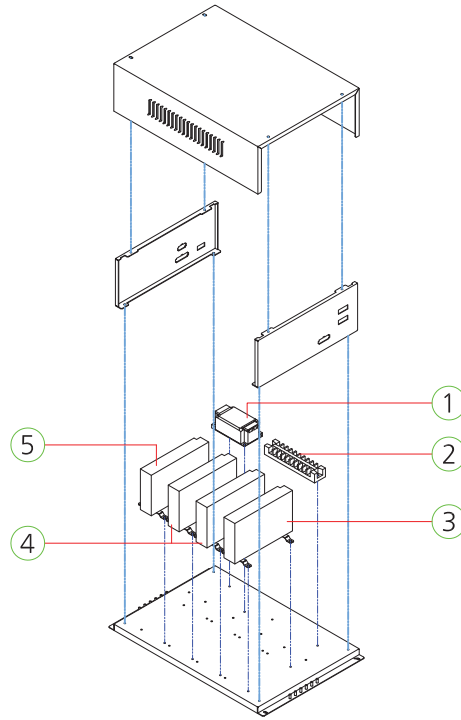

NO.	PART NAME	SPEC.	QUANTITY	CODE NO.
1	NOISE FILTER	RNS-2010	1	MELE0NOI009
2	TERMINAL BLOCK	250V 10P	1	MELE0TEB003
3	SMPS	LRS 150F_24	1	MELE0SMP085
4	SMPS	LRS 150F_12	2	MELE0SMP090
5	SMPS	LRS 150F_5	1	MELE0SMP096

6-14. FRONT LOWER DOOR PART

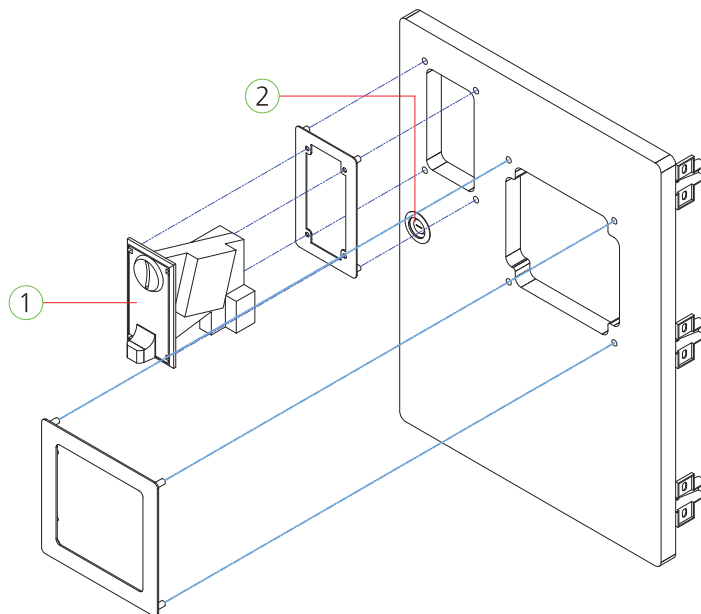

NO.	PART NAME	SPEC.	QUANTITY	CODE NO.
1	[OPTION] COIN SELECTOR	TW-389	1	MZZZ0COS052
2	KEY ASS'Y	7001	1	MZZZ0KEY076

6-15. REAR LIGHTING-L PART

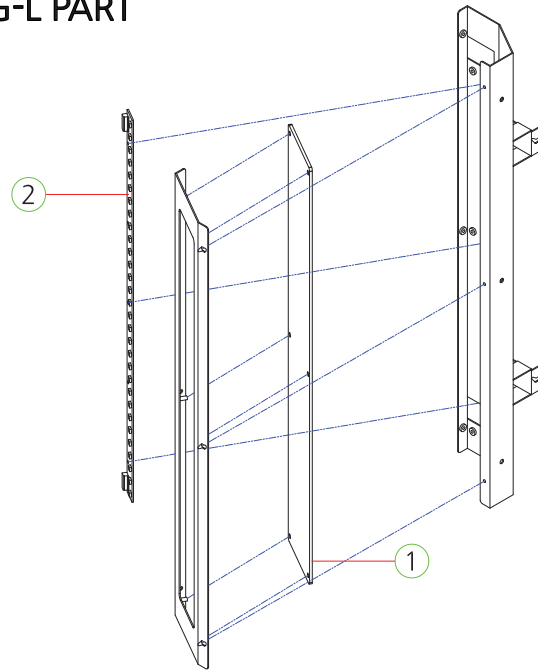

NO.	PART NAME	SPEC.	QUANTITY	CODE NO.
1	CABINET SIDE REAR LED ACRYL	ACRYL-3.0t	1	MDM30ACR022
2	WS2813B LED PCB 30EA-L ASS'Y	-	1	APLX0PCB006
R_PART	WS2813B LED PCB 30EA-R ASS'Y	-	1	APLX0PCB007

6-16. GAME PLATE MIDDLE DISPLAY PART

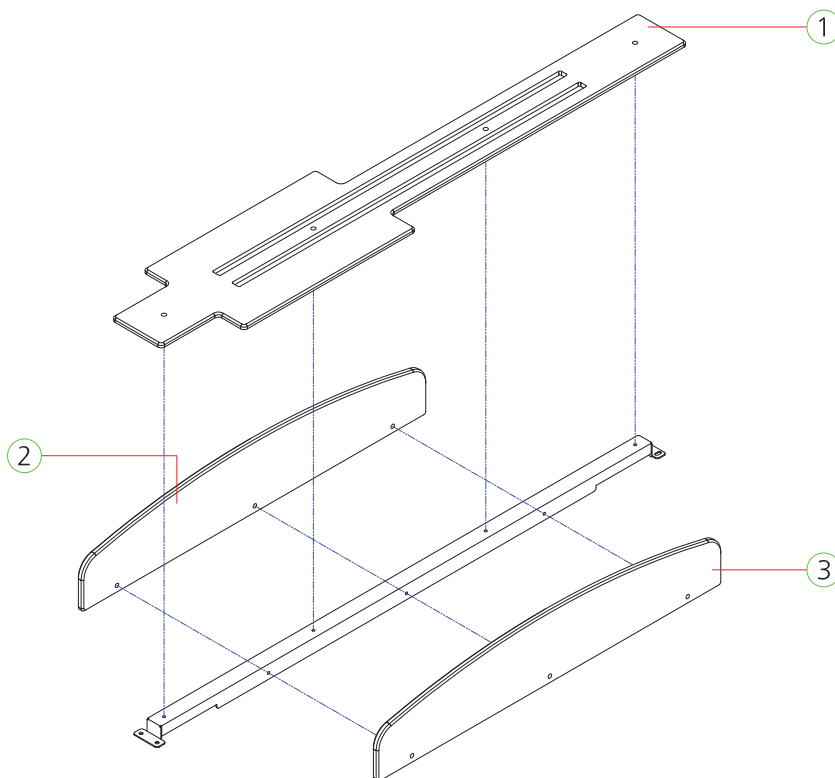

NO.	PART NAME	SPEC.	QUANTITY	CODE NO.
1	GAME PLATE MIDDLE COVER ACRYL	ACRYL-5.0t	1	MDM30ACR035
2	GAME PLATE MIDDLE ACRYL-L	ACRYL-8.0t	1	MDM30ACR033
3	GAME PLATE MIDDLE ACRYL-R	ACRYL-8.0t	1	MDM30ACR034

6-17. MAIN BOARD PART

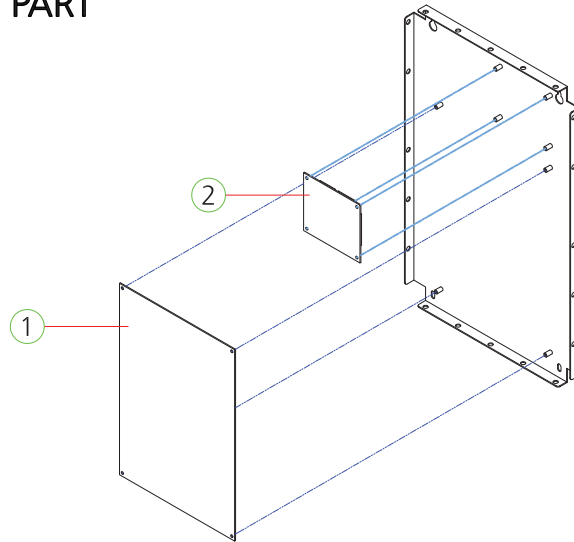

NO.	PART NAME	SPEC.	QUANTITY	CODE NO.
1	MAIN PCB ASS'Y	-	1	ADM30ASS011
2	WS2813B IO PCB ASS'Y	DM3	1	AZZZ0PCB152

6-18. BACK BOARD REAR PART

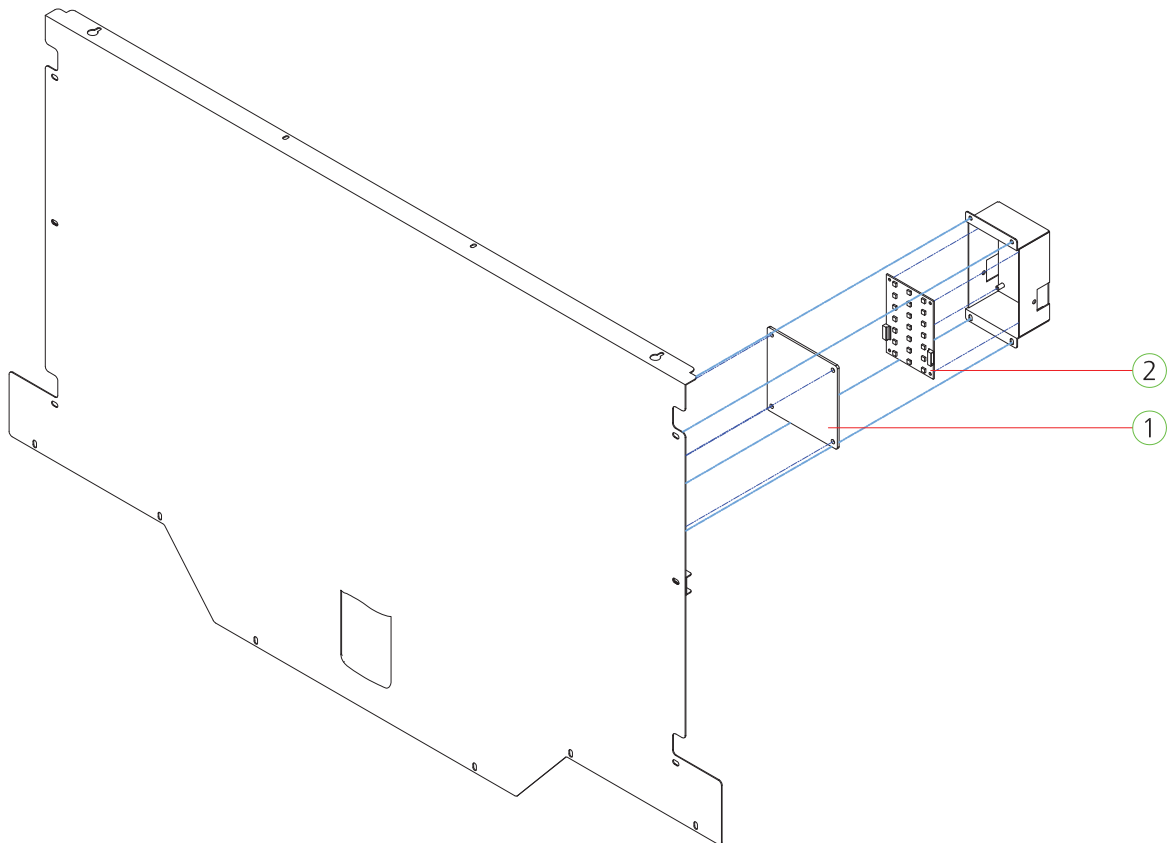

NO.	PART NAME	SPEC.	QUANTITY	CODE NO.
1	BEAKER REAR ACRYL	-	1	-
2	WS 2318B 3x7 LED	-	1	ADM30PCB005

6-19. GAME PLATE MIDDLE PCB PART

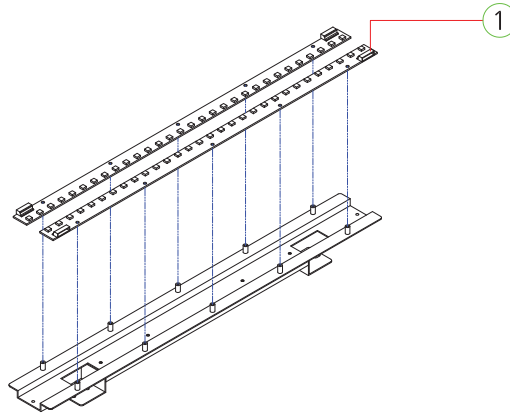

NO.	PART NAME	SPEC.	QUANTITY	CODE NO.
1	WS2813B LED PCB 30EA-L ASS'Y	-	2	APLX0PCB006

6-20. CABINET UPPER BAR LED PART

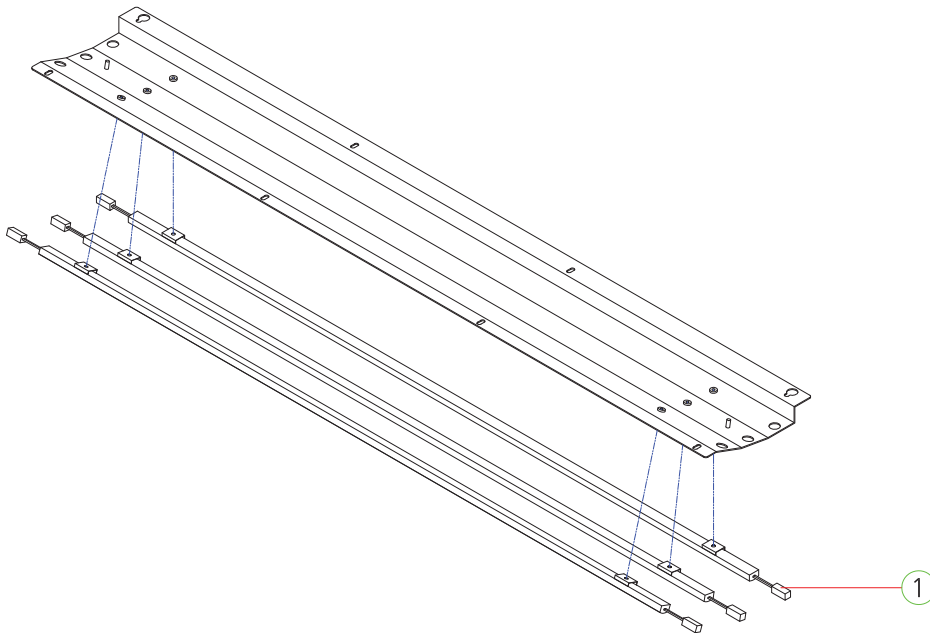

NO.	PART NAME	SPEC.	QUANTITY	CODE NO.
1	12V_LED BAR PCB ASS'Y	960mm	3	AZZ0PCB128

6-21. TOKEN DROP HOPPER PART

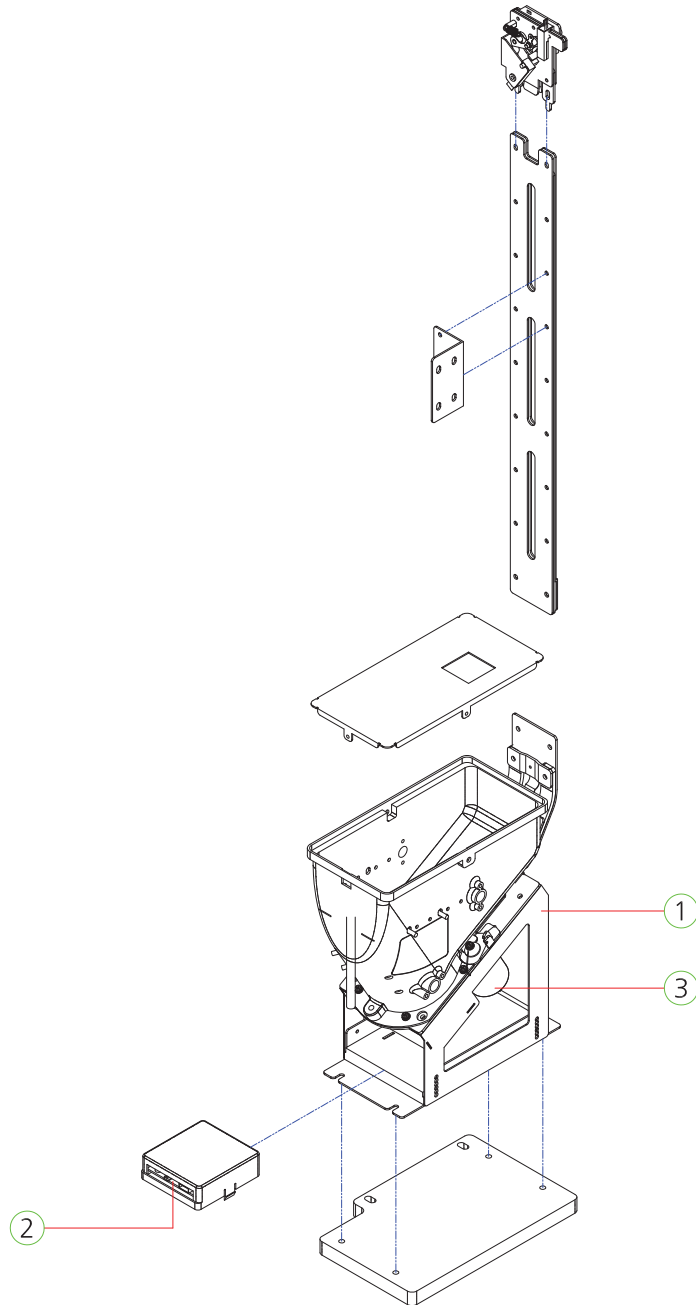

NO.	PART NAME	SPEC.	QUANTITY	CODE NO.
1	ELEVATOR HOPPER ASS'Y	-	1	AZZZ0HOP031
2	ELEVATOR HOPPER PCB ASS'Y	-	1	AZZZ0PCB143
3	ELEVATOR HOPPER MOTOR	KGV-0060-ND4266X2	1	MZZZ0ELH040

6-22. CARD OUT CHUTE PART

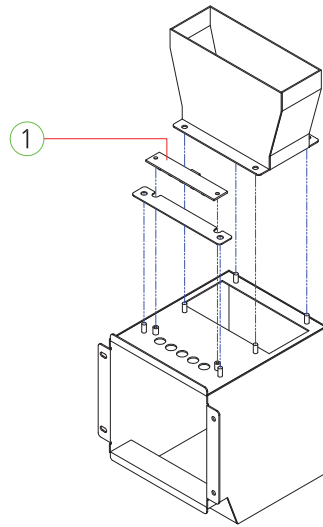

NO.	PART NAME	SPEC.	QUANTITY	CODE NO.
1	LED PCB ASS'Y	-	1	AMUM0PCB005

6-23. COIN BOX COVER PART

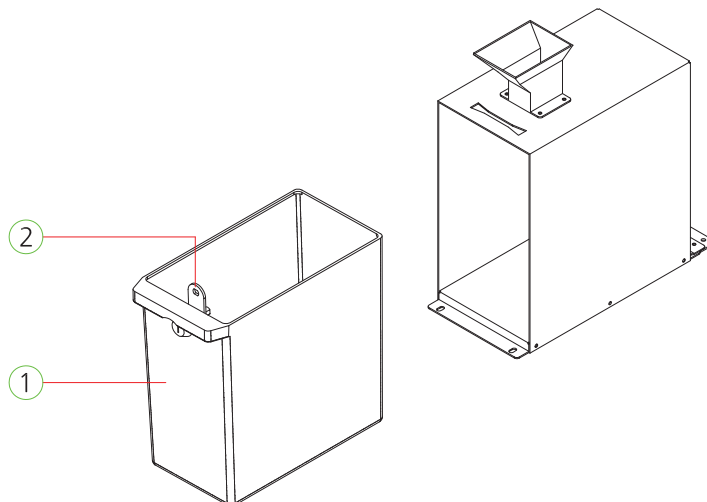

NO.	PART NAME	SPEC.	QUANTITY	CODE NO.
1	COIN BOX	BLACK	1	MDRE0PLA007
2	KEY ASS'Y	6001	1	MZZZ0KEY075

6-24. GAME BOTTOM FLEXIBLE LED PCB PART

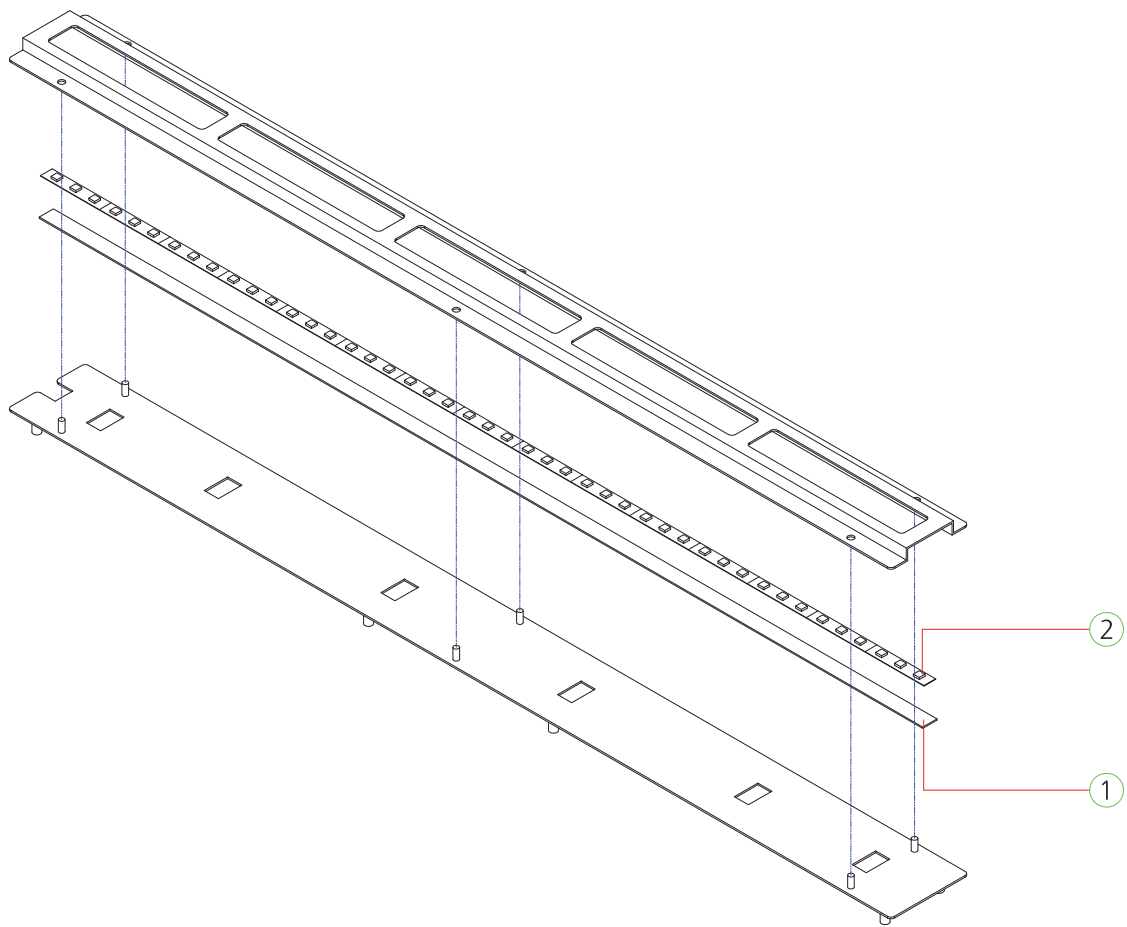

NO.	PART NAME	SPEC.	QUANTITY	CODE NO.
1	CABINET BOTTOM LED FIX ACRYL	-	1	MDM30ACR021
2	FLEXIBLE LED ASS'Y	-	1	-

MARK	DATE	REVISION

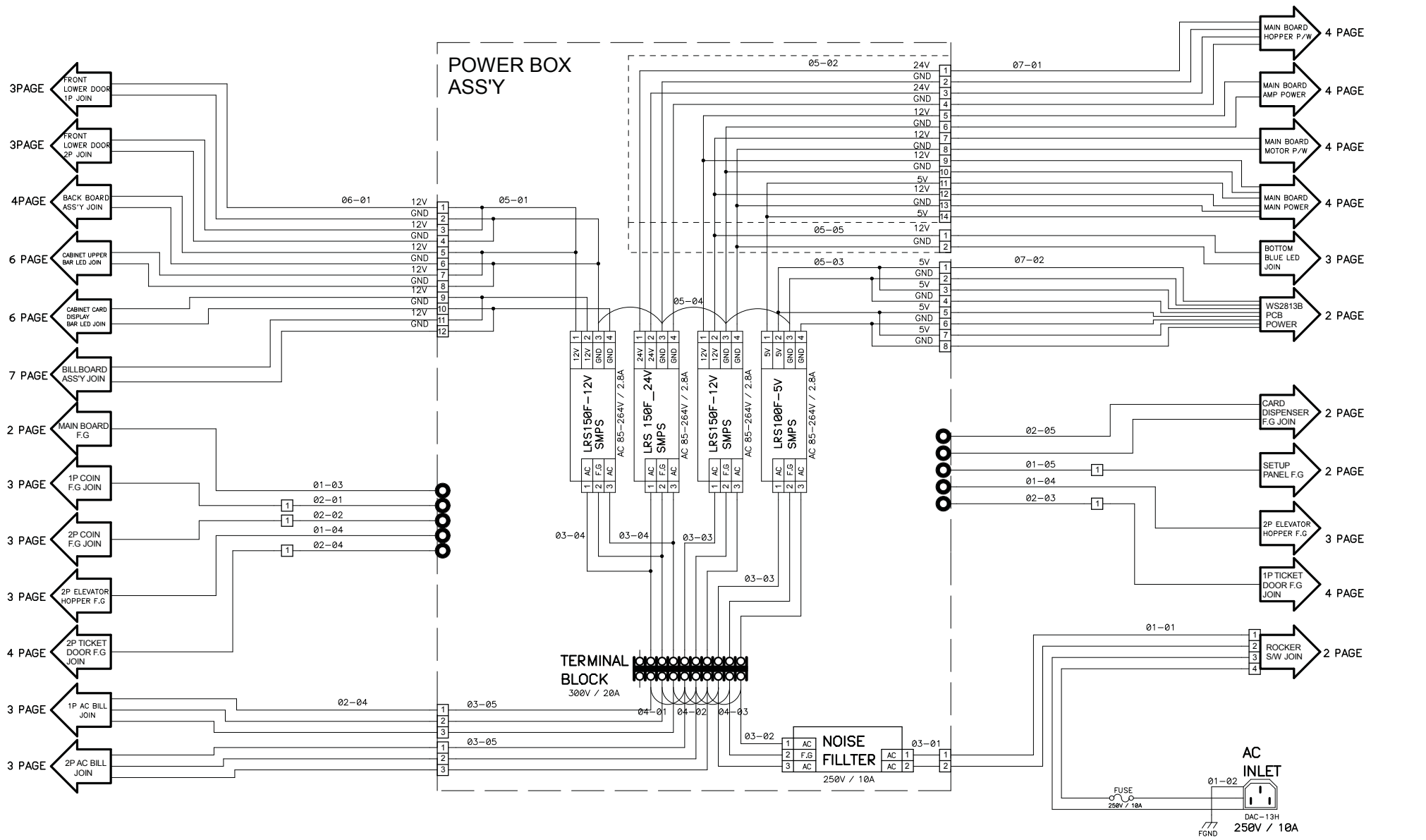

DRAWN BY	EXAMINATION	APPROVED BY	ITEM	1 PAGE
H. B. KIM			NAME	DESPICABLE ME3
			DWG.NO	
			CODE.NO	2017.06.05
			DATE	

ANDAMIRO

MARK	DATE	REVISION

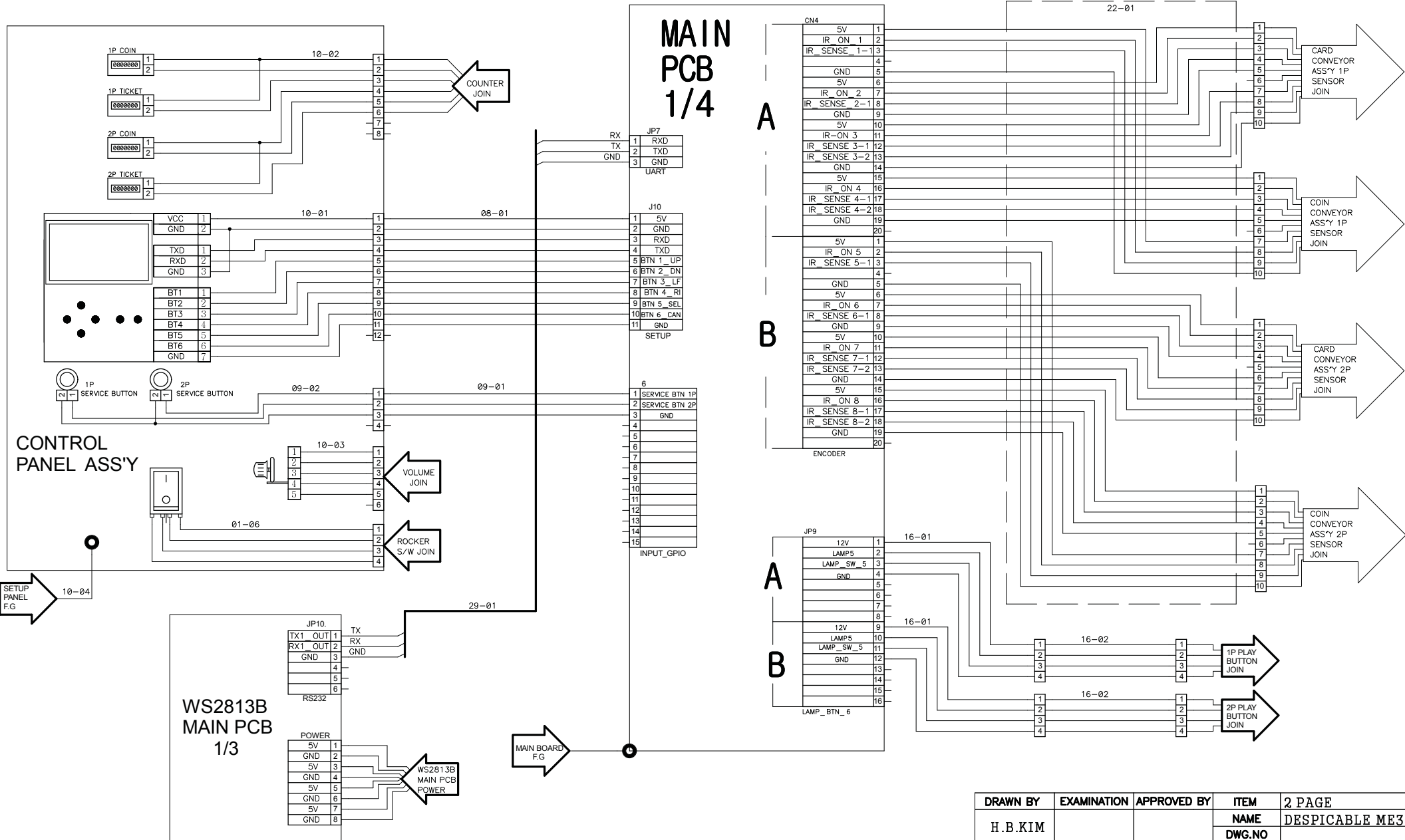

DRAWN BY	EXAMINATION	APPROVED BY	ITEM	2 PAGE
H.B.KIM			NAME	DESPICABLE ME3
ANDAMIRO			CODE.NO	2017.06.05
			DATE	

MAIN PCB 2/4

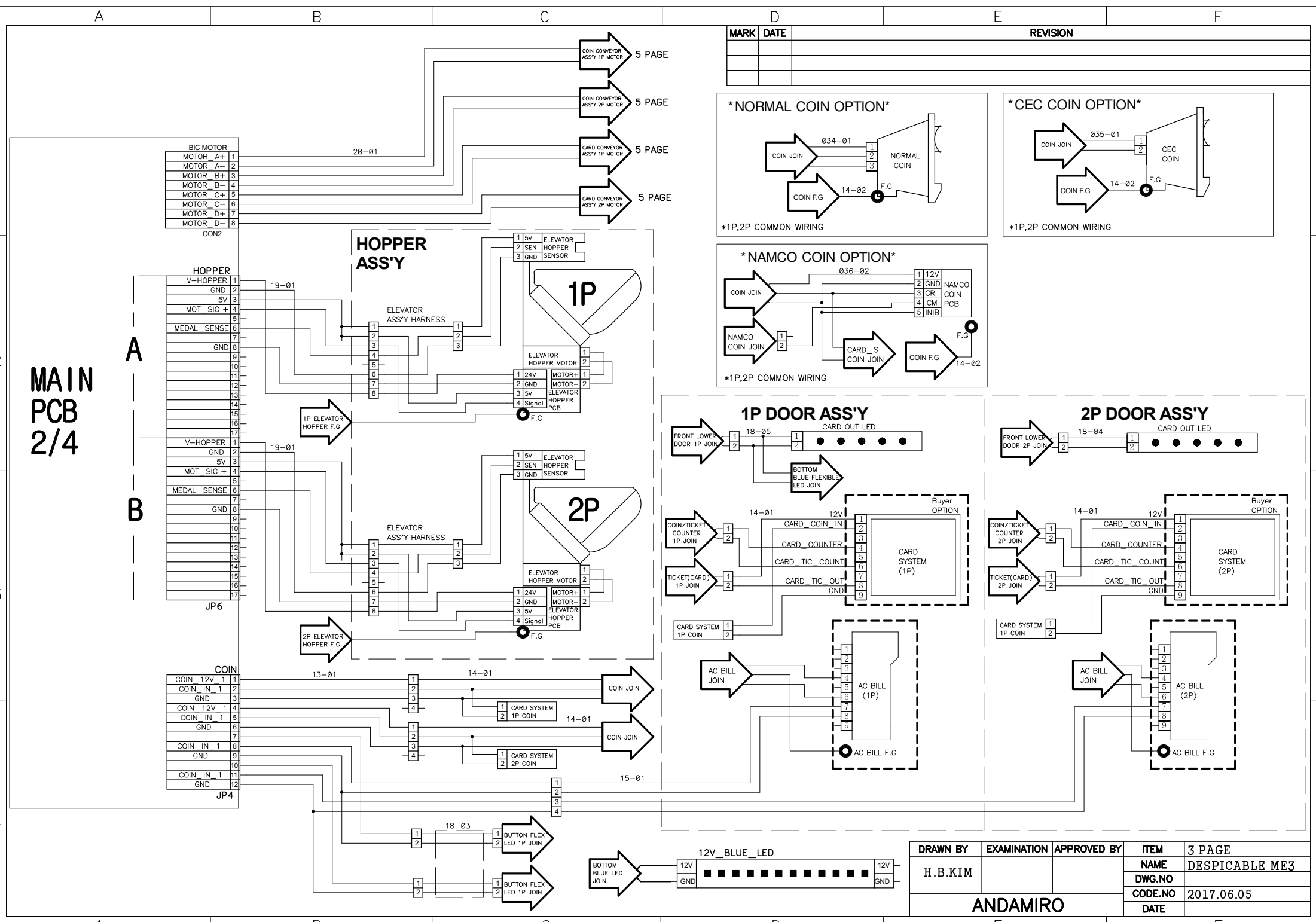

MARK	DATE	REVISION

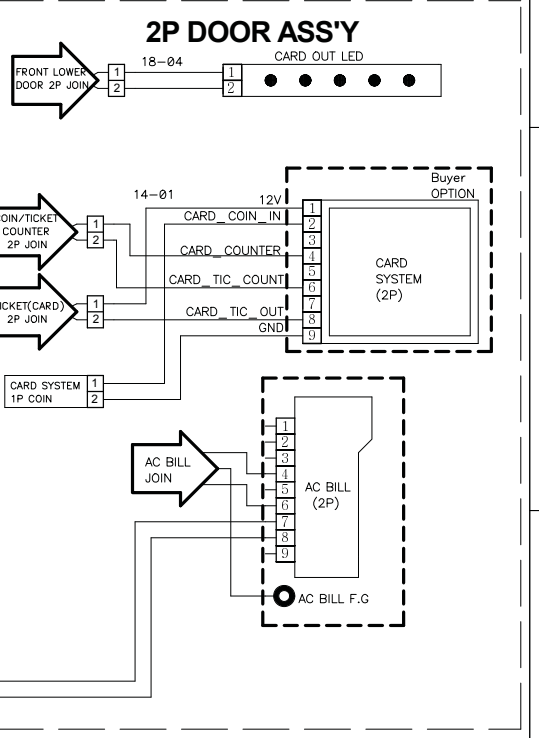
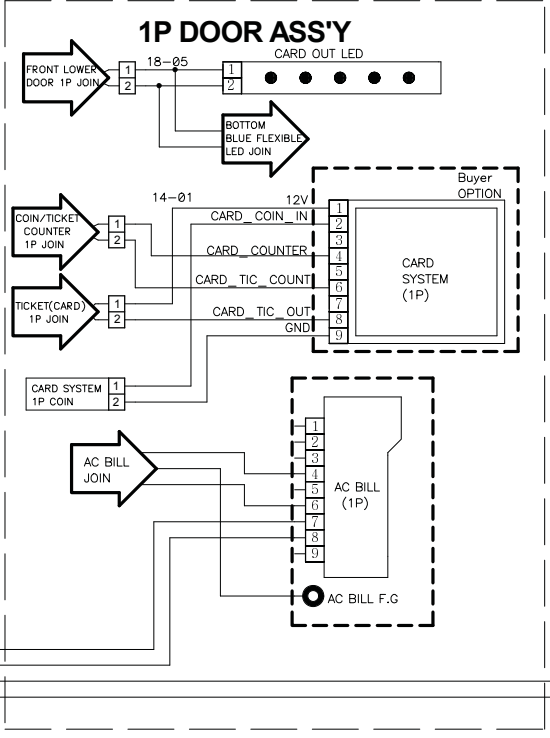
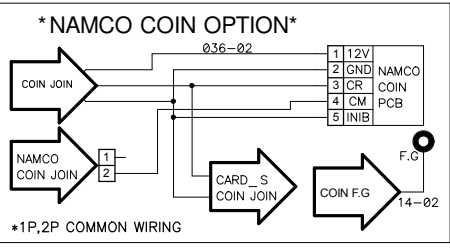
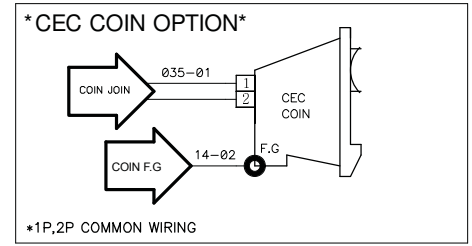
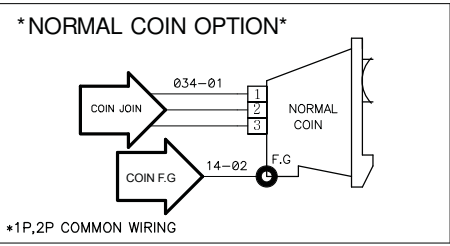

DRAWN BY	EXAMINATION	APPROVED BY	ITEM	3 PAGE
H.B.KIM			NAME	DESPICABLE ME3
			DWG.NO	
			CODE.NO	2017.06.05
			DATE	

ANDAMIRO

MARK	DATE	REVISION

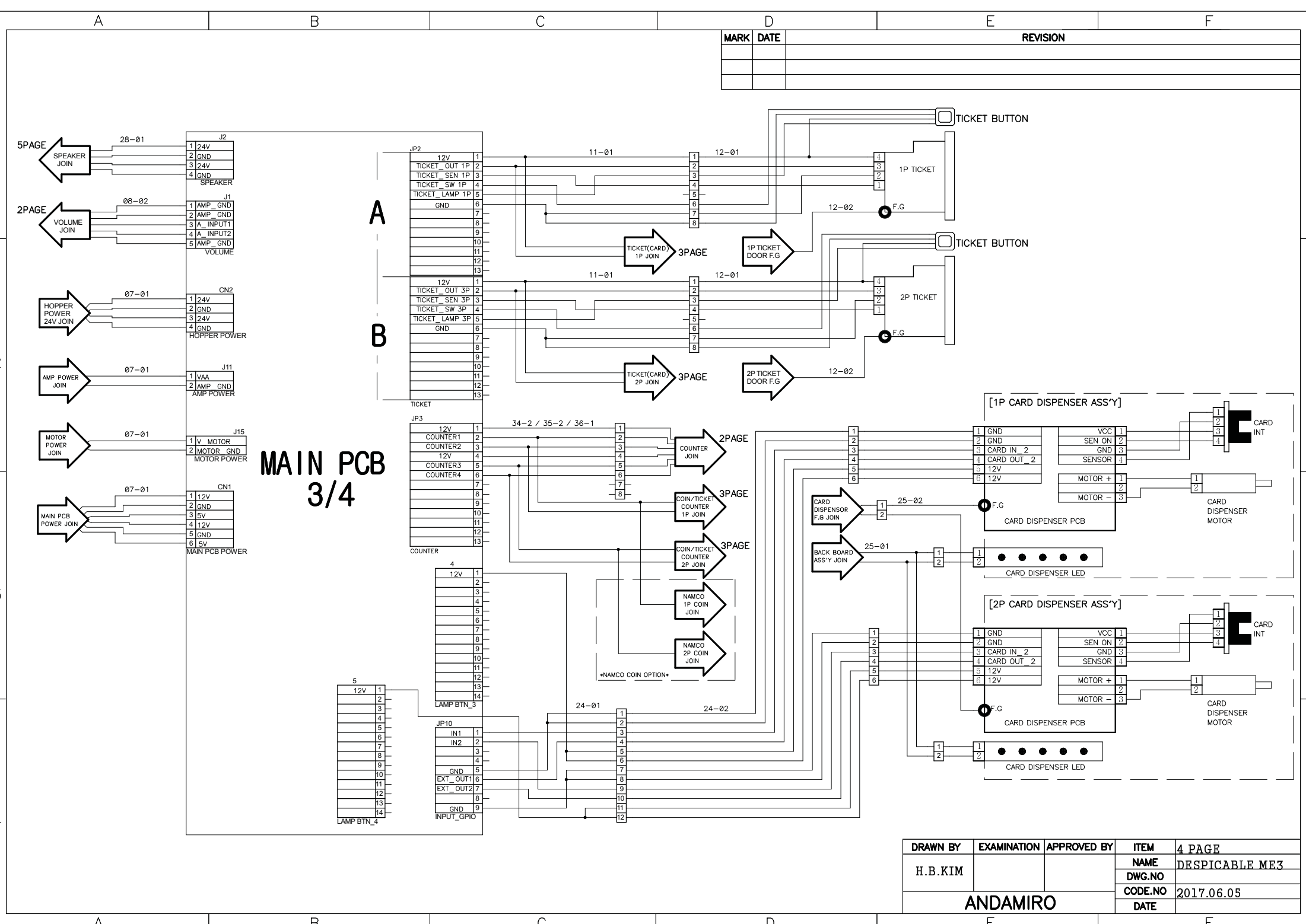

**MAIN PCB
3/4**

DRAWN BY	EXAMINATION	APPROVED BY	ITEM	4 PAGE
H.B.KIM			NAME	DESPICABLE ME3
			DWG.NO	
			CODE.NO	2017.06.05
			DATE	

ANDAMIRO

MARK	DATE	REVISION

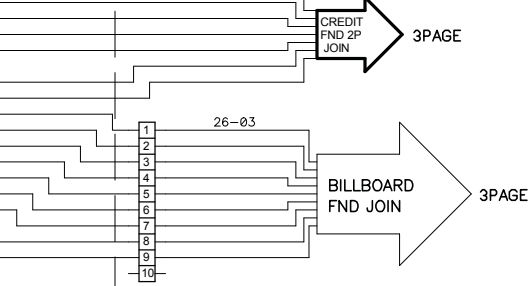
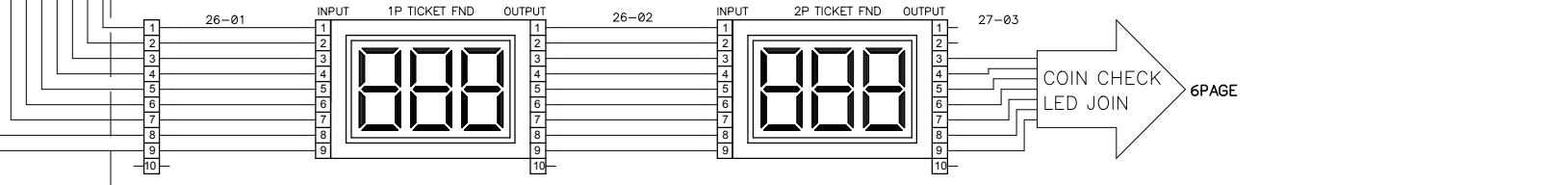
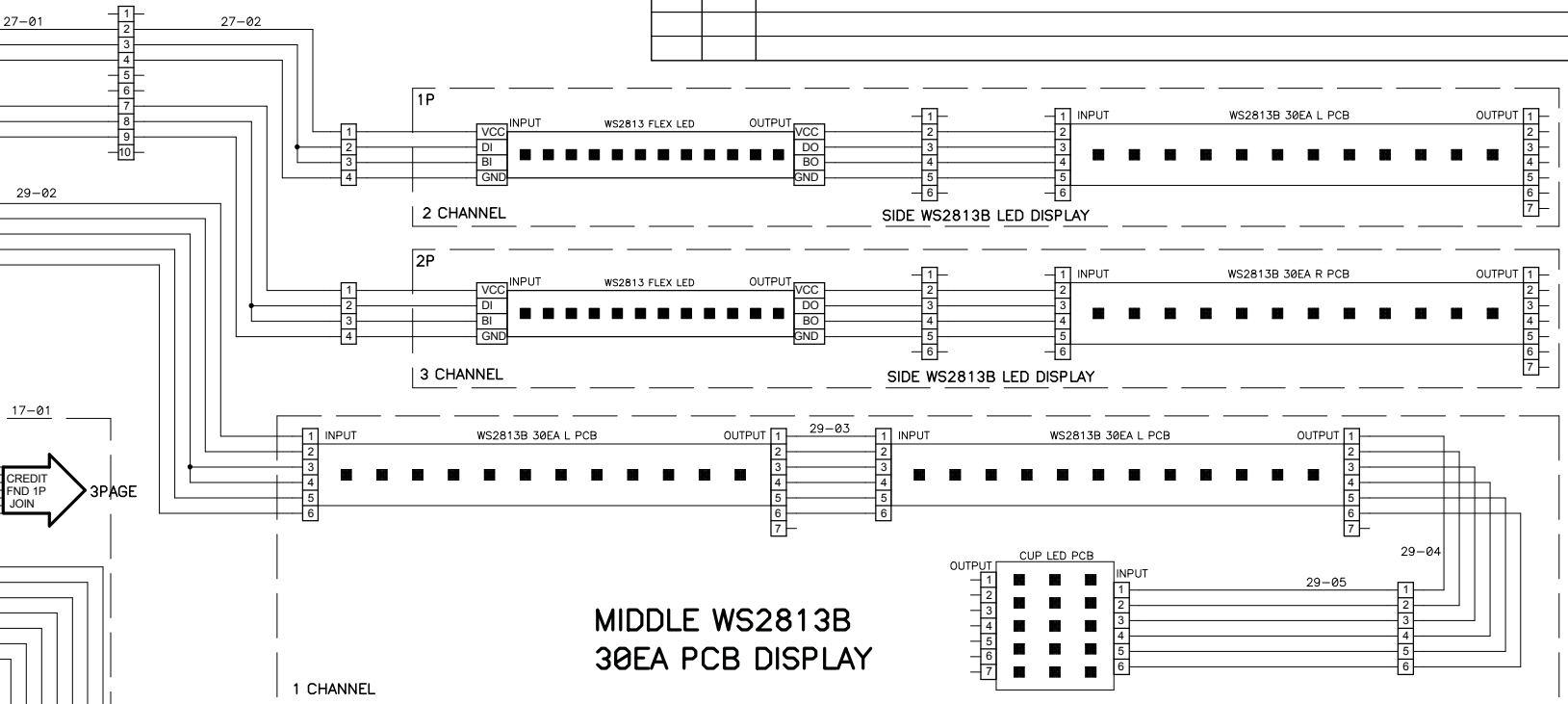
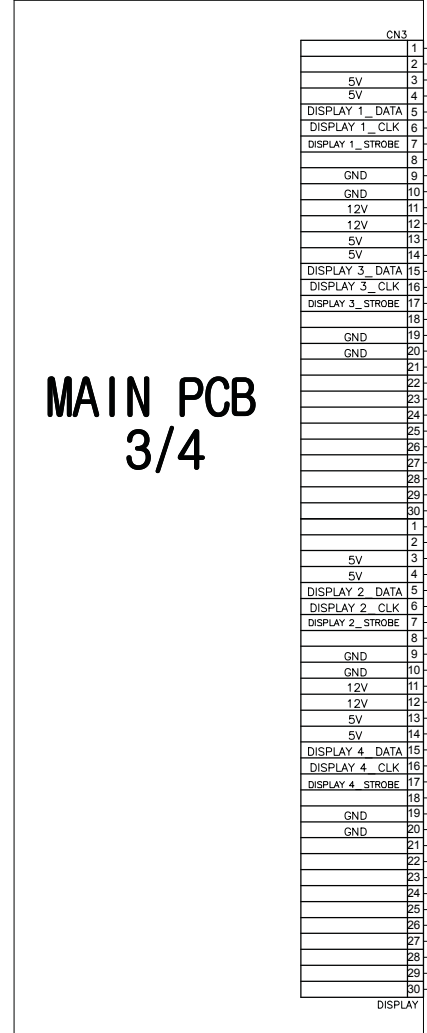
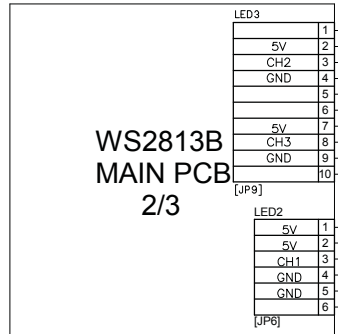

DRAWN BY	EXAMINATION	APPROVED BY	ITEM	5 PAGE
H.B.KIM			NAME	DESPICABLE ME3
ANDAMIRO			DWG.NO	
			CODE.NO	2017.06.05
			DATE	

MARK	DATE

REVISION

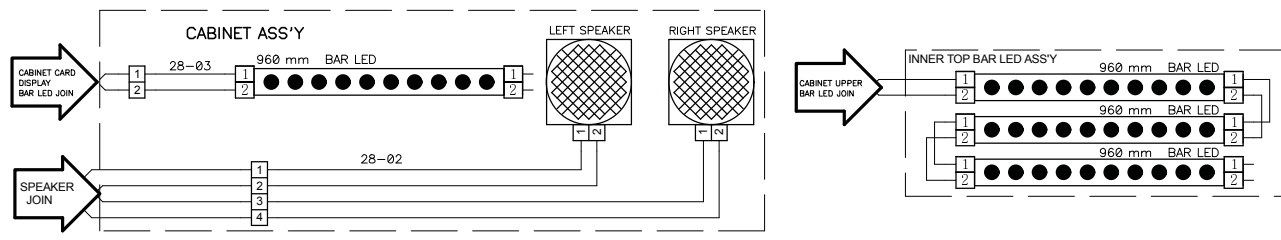
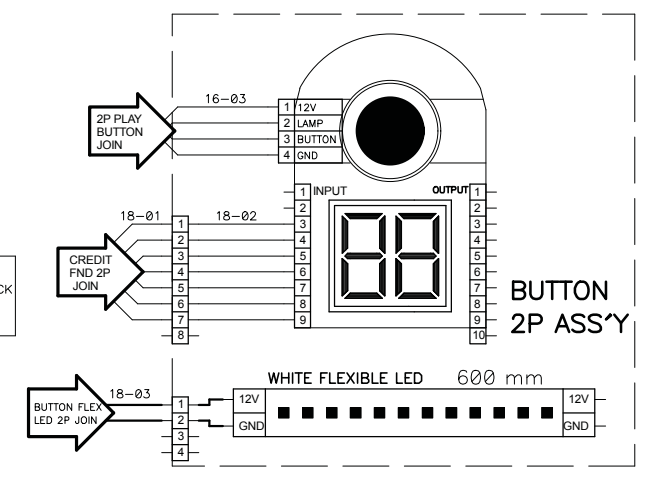
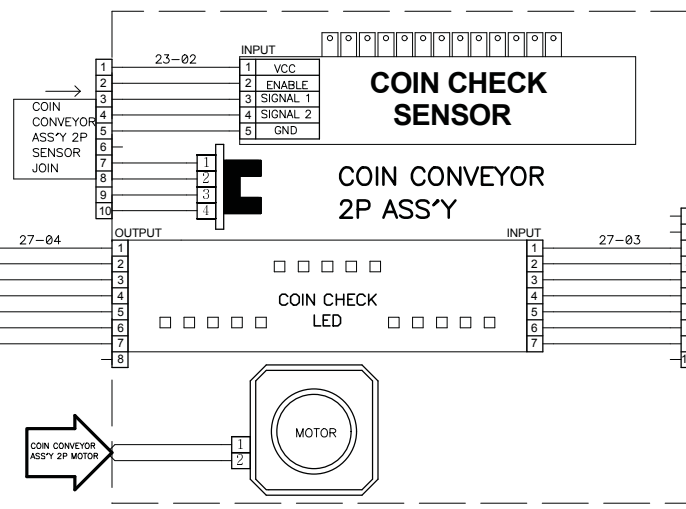
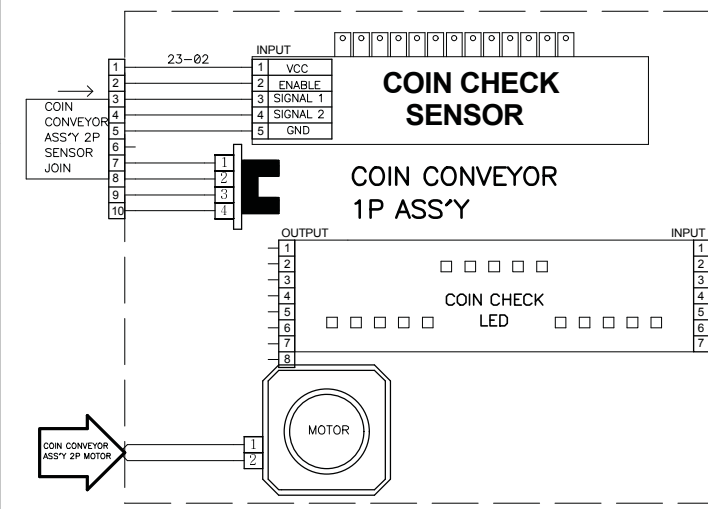
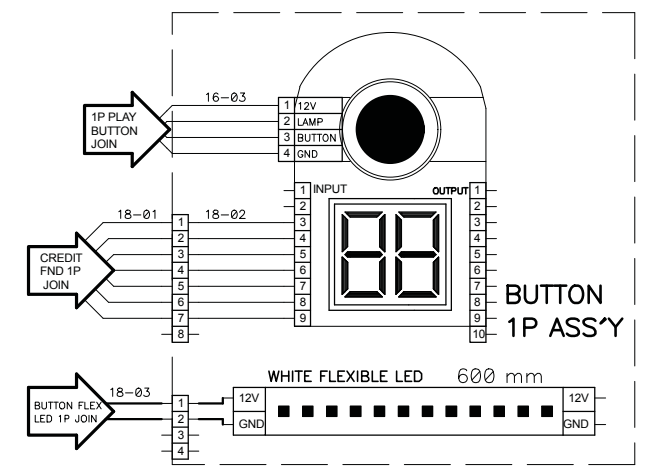
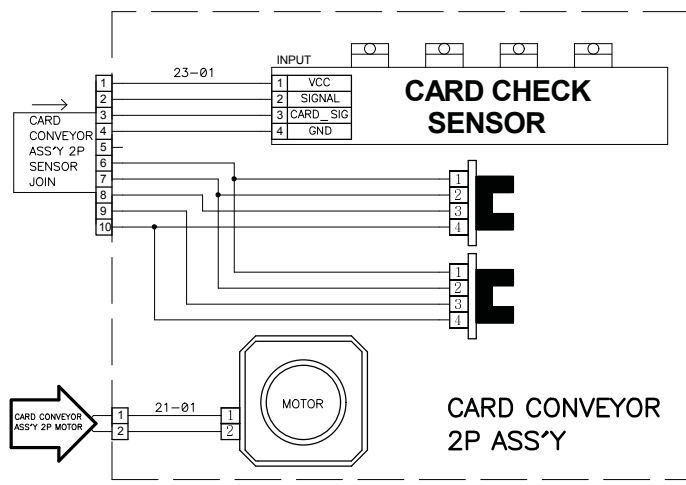
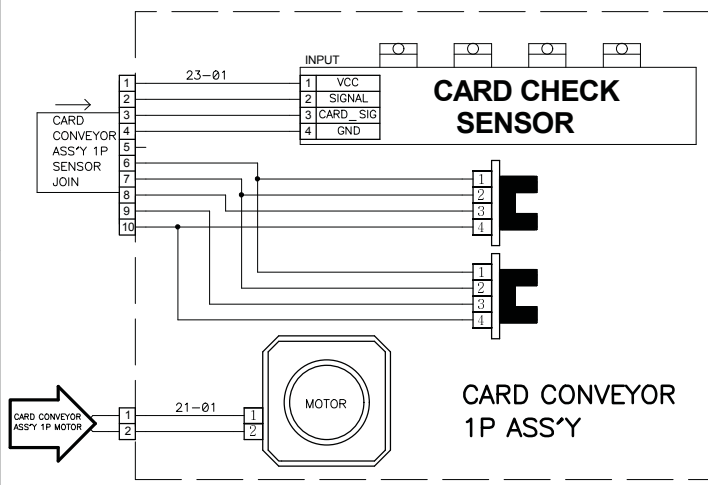

DRAWN BY	EXAMINATION	APPROVED BY	ITEM	6 PAGE
H.B.KIM			NAME	DESPICABLE ME3
			DWG.NO	
			CODE.NO	2017.06.05
			DATE	

ANDAMIRO

MARK	DATE	REVISION

4 CHANNEL

BILLBOARD WS2813B ASS'Y

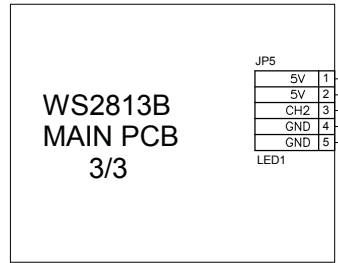
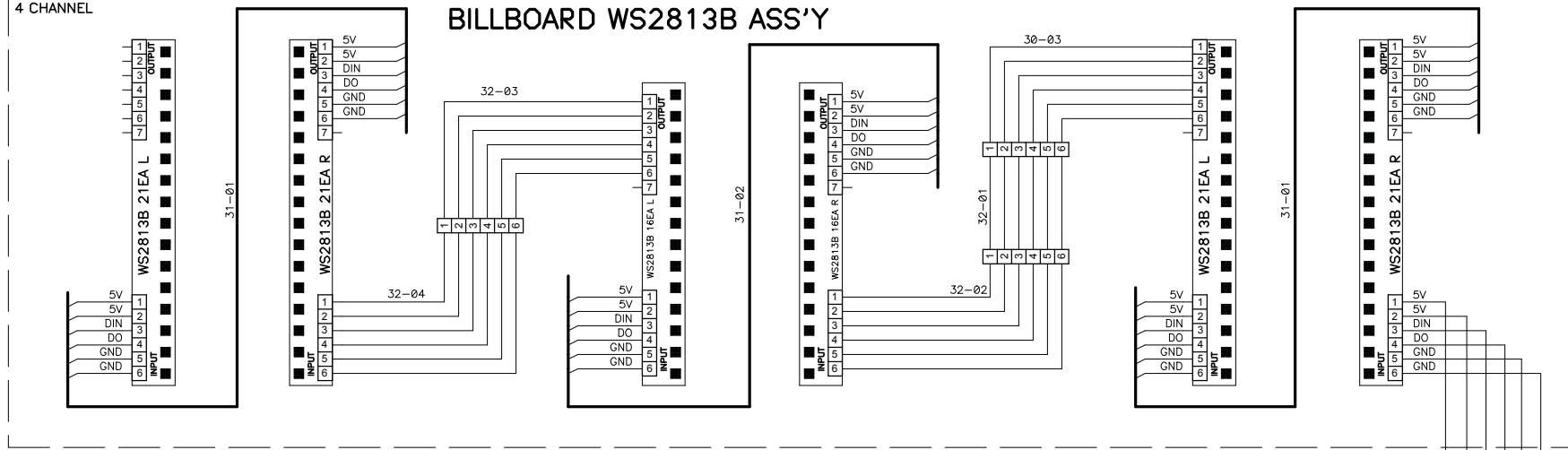

BILLBOARD ASS'Y

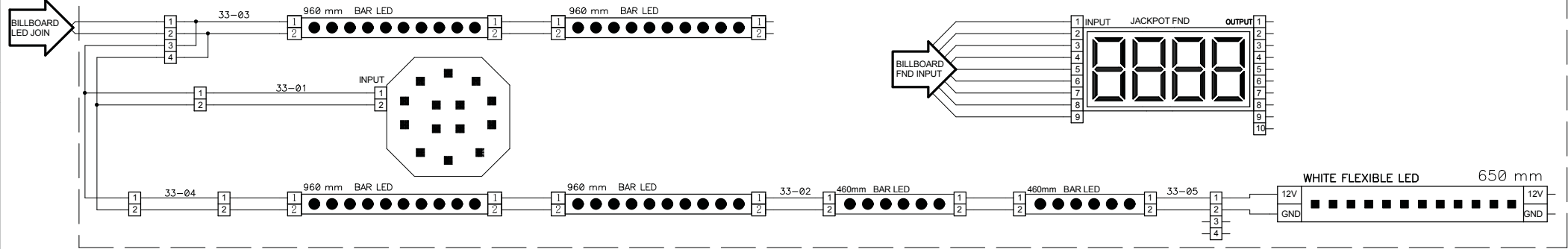

DRAWN BY	EXAMINATION	APPROVED BY	ITEM	7 PAGE
H.B.KIM			NAME	DESPICABLE ME3
ANDAMIRO			DWG.NO	2017.06.05
			CODE.NO	2017.06.05
			DATE	



ANDAMIRO WARRANTY POLICY



Andamiro warrants to the original purchaser that all of its products will be free from defects in material and workmanship.

Andamiro warrants the parts from date of shipment as follows.

- **One Year Limited Warranty : Electronic Boards & Monitor**
- **6 Month Limited Warranty : Moving Parts**

For any key components within the warranty period, Andamiro will repair or replace defective components free of charge.

When placing a warranty request, the customer is requested to furnish the following information:

1. Name of the game.
2. Serial Number of the game.
3. A Detailed Description of the defect/s experienced.

This warranty does not apply to the defects caused due to misuse or abuse of the product.

Any alterations made to game or game parts will void this warranty.

For warranty details on our product range please visit our website, www.andamiro.com.

ANDAMIRO CO., LTD.
www.andamiro.com



Please complete the following request form to place a warranty request and send it to ANDAMIRO Korea either by fax (Fax No: +82-31-908-7548) or by e-mail. The e-mail address of the person in charge of each region is shown in our web-site, www.andamiro.com

For the on-line request, please visit our web-site, www.andamiro.com and click "Customer Service" and then click "Contact Us" in which you shall find the e-mail address of the person in charge of each region.

1. Company Name : _____

2. Mailing Address : _____

3. E-Mail Address : _____

4. Phone No : _____

5. Name of the person in charge : _____

6. Description of the product defects

6-1) Name of the Game : _____

6-2) Serial No : _____

6-3) Date of Purchase : _____

6-4) Detailed description of the product defects.

Remarks: If possible, please provide us with related photos and videos which will be greatly appreciated to verify the cause of the problem.



ANDAMIRO CO., LTD.
TEL : 82-31-909-2123~4,2051

[ADDRESS OFFICE] 6006 M-City Tower, 195, Baengmaro, Ilsandong-gu, Goyang-si,
Gyeonggi-do, 410-834 Korea
[FACTORY] 72 Nochemgil, Ilsan-donggu Goyang-si, Gyeonggi-do, 410-834 korea

USA BRANCH
ANDAMIRO USA CORP.
17230 S. Main Street
TEL : 1-310-767-5800

[ADDRESS] Gardena, California 90248 U.S.A.

Homepage <http://www.andamiro.com/>