

2<sup>nd</sup> PRINTING  
MAY 2017



Sega Amusements International Limited.  
42 Barwell Business Park, Leatherhead Road, Chessington, Surrey, KT9 2NY. United Kingdom.  
Telephone: +44 (0) 208 391 8090 Facsimile: +44 (0) 208 391 8099  
mailbox@sega.co.uk segaarcade.com

Sega Games Co., Ltd.  
1-2-12, Haneda, Ota-ku, Tokyo, 144-8531. Japan.  
Telephone: +81-3-5736-7111 Facsimile: +81-3-6871-7672  
sega-games.co.jp

© SEGA  
Errors and omissions excepted (E&OE)

DAYTONA CHAMPIONSHIP USA

OWNER'S MANUAL

420-0028-01K



## OWNER'S MANUAL



### IMPORTANT

- Before using this product, read this manual carefully to understand the contents herein stated.
- After reading this manual, be sure to keep it near the product or in a convenient place for easy reference when necessary.

## BEFORE USING THE PRODUCT, BE SURE TO READ THE FOLLOWING:

### To maintain safety:

To ensure the safe operation of this product, be sure to read the following before usage.

The following instructions are intended for the users, operators and the personnel in charge of the operation of the product. After carefully reading and sufficiently understanding the warning displays and cautions, handle the product appropriately. Be sure to keep this manual close to the product or in a convenient place for future reference.

Herein, explanations which require special attention are enclosed with dual lines. Depending on the potentially hazardous degrees, the terms of DANGER, WARNING, CAUTION, etc. are used. Be sure to understand the contents of the displays before reading the text.

 **DANGER** Indicates that mishandling the product by disregarding this pictograph will cause severe injury or death.

 **WARNING** Indicates that mishandling the product by disregarding this warning will cause a potentially hazardous situation which can result in death or serious injury.

 **CAUTION** Indicates that mishandling the product by disregarding this caution will cause a slight hazardous situation which can result in personal injury and/or material damage.

### For the safe usage of the product, the following pictographs are used:

 Indicates "HANDLE WITH CARE." In order to protect the human body and equipment, this display is attached to places where the Owner's Manual, Serviceman Manual and/or Service Manual should be referred to.

- **Perform work in accordance with the instructions herein stated.** Instructions for work are explained by paying attention to the aspect of accident prevention. Failing to perform work as per the instructions can cause accidents. In the case where only those who have technical expertise should perform the work to avoid hazardous situation, the instructions herein state that the site maintenance personnel should perform such work.
- **Be sure to turn off the power before working on the machine.** To prevent an electric shock, be sure to turn off the power before carrying out any work that requires direct contact with the interior of the product. If the work is to be performed in the power-on status, the Instruction Manual herein always states to that effect.
- **Be sure to ground the Earth Terminal.** (This is not required in the case where a power cord with earth is used.)
- **This product is equipped with the Earth Terminal.** When installing the product, connect the Earth Terminal to the "accurately grounded indoor earth terminal" by using an earth wire. Unless the product is grounded appropriately, the user can be subject to an electric shock. After performing repair, etc. for the control equipment, ensure that the Earth Wire is firmly connected to the control equipment.
- **Ensure that the Power Supply used is equipped with an Earth Leakage Breaker.** This product does not incorporate the Earth Leakage Breaker. Using a power supply which is not equipped with the Earth Leakage Breaker can cause a fire when earth leakage occurs.
- **Be sure to use fuses which meet the specified rating.** (Only for the machines which use fuses.) Using fuses exceeding the specified rating can cause a fire and an electric shock. (Only for the machines which use fuses.) Using fuses exceeding the specified rating can cause a fire and an electric shock.

- **Specification changes (removal of equipment, conversion and addition) not designated by SEGA are not allowed.** The parts of the product include warning labels for safety, covers for personal protection, etc. It is very hazardous to operate the product by removing parts and/or modifying the circuits. Should doors, lids and protective parts be damaged or lost, refrain from operating the product, and contact where the product was purchased from or the office herein stated. SEGA shall not be held responsible for any accidents, compensation for damage to a third party, resulting from the specifications not designated by SEGA.
- Ensure that the product meets the requirements of appropriate electrical specifications. Before installing the product, check for electrical specifications. SEGA products have a nameplate on which electrical specifications are described. Ensure that the product is compatible with the power supply voltage and frequency requirements of the location. Using any electrical specifications different from the designated specifications can cause a fire and an electric shock.
- Install and operate the product in places where appropriate lighting is available, allowing warning labels to be clearly read. To ensure safety for the customers, labels and printed instructions describing potentially hazardous situations are applied to places where accidents can be caused. Ensure that where the product is operated has sufficient lighting allowing the warnings to be read. If any label is peeled off, apply it again immediately. Please place an order with where the product was purchased from or the office herein stated.
- When handling the monitor, be very careful. (Applies only to products with monitors.) Some of the monitor parts are subject to high tension voltage. Even after turning off the power, some portions are still subject to high tension voltage sometimes. Monitor repair and replacement should be performed only by those technical personnel who have knowledge of electricity and technical expertise.
- Be sure to adjust the monitor properly. (Applies only to products with monitors.) Do not operate the product leaving on-screen flickering or blurring as it is. Using the product with the monitor not properly adjusted may cause dizziness or a headache to an operator, a player, or the customers.
- When transporting or reselling this product, be sure to attach this manual to the product.
- *In the case where commercially available monitors and printers are used in this product, only the contents relating to this product are explained herein. Some commercially available equipment has functions and reactions not stated in this manual. Read this manual together with the specific instruction manual of such equipment.*
- *Descriptions herein contained may be subject to improvement changes without notice.*
- *The contents described herein are fully prepared with due care. However, should any question arise or errors be found, please contact SEGA.*

## INSPECTIONS IMMEDIATELY AFTER TRANSPORTING THE PRODUCT TO THE LOCATION

Normally, at the time of shipment, SEGA products are in a status allowing for usage immediately after transporting to the location. Nevertheless, an irregular situation may occur during transportation. Before turning on the power, check the following points to ensure that the product has been transported in a satisfactory status.

- Are there any dented portions or defects (cuts, etc.) on the external surfaces of the cabinet?
- Are casters and adjusters damaged?
- Do the power supply voltage and frequency requirements meet with those of the location?
- Are all wiring connectors correctly and securely connected? Unless connected in the correct way, connector connections can not be made accurately. Do not insert connectors forcibly.
- Do power cables have cuts and dents?
- Are all accessories available?
- Can all doors and lids be opened with the accessory keys? Can doors and lids be firmly closed?

# TABLE OF CONTENTS

	<b>INTRODUCTION</b>	<b>vi</b>
<b>1</b>	<b>HANDLING PRECAUTIONS</b>	<b>1</b>
<b>2</b>	<b>PRECAUTIONS REGARDING INSTALLATION LOCATION</b>	<b>4</b>
	2-1 LIMITATIONS OF USAGE	5
	2-2 OPERATION AREA	6
	2-3 OPERATION AREA - MULTIPLE CABINETS	7
<b>3</b>	<b>PRECAUTIONS REGARDING PRODUCT OPERATION</b>	<b>9</b>
	3-1 BEFORE OPERATION	9
	3-2 DURING OPERATION (PAYING ATTENTION TO CUSTOMERS)	12
<b>4</b>	<b>PARTS DESCRIPTION</b>	<b>14</b>
<b>5</b>	<b>ACCESSORIES</b>	<b>15</b>
<b>6</b>	<b>ASSEMBLY AND INSTALLATION</b>	<b>17</b>
	6-1 UNPACKING THE CABINETS	20
	6-2 ATTACHING THE BILLBOARD W/MONITOR	23
	6-3 JOINING THE CABINETS	26
	6-4 INSTALLING MULTIPLE CABINETS	29
	6-5 LINKING THE CABINETS (COMMUNICATION)	30
	6-6 APPLYING POWER	31
<b>7</b>	<b>PRECAUTIONS WHEN MOVING</b>	<b>34</b>
	7-1 MOVING THE MACHINE	35
<b>8</b>	<b>GAME DESCRIPTION</b>	<b>37</b>
<b>9</b>	<b>EXPLANATION OF TEST AND DATA DISPLAY</b>	<b>48</b>
	9-1 SWITCH UNIT	49
	9-2 TEST MODE	50
<b>10</b>	<b>VIDEO DISPLAY</b>	<b>71</b>
	10-1 GENERAL DESCRIPTION	71
	10-2 CLEANING THE SCREEN	72
	10-3 ADJUSTMENT METHOD	73
<b>11</b>	<b>CONTROL UNITS</b>	<b>77</b>
	11-1 CONTROLLER - EXPLODED DIAGRAM	79
	11-2 BRAKE AND ACCELERATOR UNIT	80
	11-3 ADJUSTING/REPLACING THE VOLUME POT	82
	11-4 GREASING	83
	11-5 SHIFT LEVER	84

<b>12</b>	<b>ACTIVE BILLBOARD</b>	<b>86</b>
	12-1 ACTIVE COMPONENTS - SERIAL LED	87
	12-2 ACTIVE COMPONENTS - SECONDARY DISPLAY	89
<b>13</b>	<b>COIN HANDLING</b>	<b>91</b>
	13-1 CLEANING THE COIN SELECTOR	91
	13-2 FAULT FINDING	94
	13-3 ADJUSTING THE PRICE OF PLAY (EXCEL)	95
	13-4 ADJUSTING THE PRICE COMMON (USA)	96
<b>14</b>	<b>LAMPS AND LIGHTING</b>	<b>99</b>
	14-1 COIN DOOR LAMP	99
	14-2 START/VIEW BUTTON PANEL	100
	14-3 CONTROL PANEL DIALS	102
	14-4 FOOTWELL LIGHTING	104
	14-5 ENGINE LIGHTING UPPER	106
	14-6 ENGINE LIGHTING LOWER	109
	14-7 SEAT BACK LIGHTING	110
	14-8 HEADREST LIGHTING	113
	14-9 BILLBOARD LIGHTING	114
<b>15</b>	<b>PERIODIC INSPECTION</b>	<b>115</b>
	15-1 GREASING	117
<b>16</b>	<b>TROUBLESHOOTING &amp; ERROR CODES</b>	<b>118</b>
<b>17</b>	<b>GAME BOARD</b>	<b>123</b>
	17-1 HOW TO REMOVE GAME BOARD	124
	16-2 GAME BOARD CONNECTORS	126
<b>18</b>	<b>DESIGN RELATED PARTS</b>	<b>127</b>
<b>19</b>	<b>PARTS LIST</b>	<b>128</b>
	TOP ASSY DAYTONA CHAMPIONSHIP USA (DA-0000UK)	129
	ASSY MONITOR CABI (DA-1000UK)	130
	ASSY 46" LED AUO MONITOR	132
	ASSY CONTROL PANEL	133
	ASSY CONTROL PANEL (DA-2000UK)	134
	ASSY AC UNIT (DA1080UK)	136
	ASSY FAN (SND-1340UK)	137
	ASSY GAME BD (DA-4500UK)	138
	ASSY ELEC BD (DA-4600UK)	139
	ASSY SW UNIT (DA-1320UK)	140
	ASSY SW UNIT COVER (DA-1330UK)	141
	ASSY CAMERA MODULE (DA-1350UK)	142
	ASSY COIN CHUTE TOWER (DA-0300UK)	143
	ASSY EXCEL & METER UNIT (DA-0320UK)	144

	ASSY SEAT CABI EXT (DA-3500UK)	145
	ASSY SEAT BASE EXT (DA-3600UK)	146
	ASSY SEAT BASE EXT (DA-3600UK)	147
	ASSY ENGINE SUB (DA-3350UK)	148
	ASSY ADJUSTABLE SEAT EXT (DA-3700UK)	...149
	ASSY ADJUSTABLE SEAT EXT (DA-3700UK)	150
	ASSY ADJUSTABLE SEAT EXT (DA-3700UK)	151
	ASSY INSTALLATION KIT (DA-INST-STD)	152
	ASSY BILLBOARD W/MON (DA-0800UK)	153
	ASSY BILLBOARD W/MON (DA-0800UK)	154
<b>20</b>	<b>WIRE COLOUR CODE TABLE</b>	<b>155</b>
<b>21</b>	<b>SCHEMATIC DIAGRAMS (1 OF 3)</b>	<b>156</b>

# INTRODUCTION

This manual is intended to provide detailed descriptions together with all necessary information covering the general operation of electronic assemblies, electromechanical, servicing control, spare parts, etc. for the product, "DAYTONA CHAMPIONSHIP USA"

This manual is intended for the owners, personnel managers in charge of operation of this product. Operate the product after carefully reading and sufficiently understanding the instructions.

In the unlikely event that the product does not function correctly, DO NOT allow anyone other than a technician to touch the internal system. Turn off the power to the machine, making sure to unplug the electrical cord from the outlet, and contact the office listed below or the point-of-purchase for this product.

Use of this product is unlikely to cause physical injuries or damage to property. However, points that require special attention are indicated by bold text, the words "STOP, IMPORTANT or CAUTION" and the symbols below.

## **IMPORTANT**

**Indicates important information that, if ignored, may result in the mishandling of the product and cause faulty operation or damage to the product.**

## **WARNING**    **CAUTION**

**Indicates a warning or caution that, if ignored, may result in the mishandling of the product and cause faulty operation or damage to the product.**

### Sega Amusements International Limited.

42 Barwell Business Park, Leatherhead Road, Chessington, Surrey, KT9 2NY. United Kingdom.

European Sales:	+44 (0) 208 391 8090	Facsimile:	+44 (0) 208 391 8099
email:	mailbox@sega.co.uk	Web:	http://www.segaarcade.com

### Sega Games Co., Ltd.

1-2-12. Haneda, Ota-ku, Tokyo. 144-8531 JAPAN

Telephone:	+81-3-5736 7111	Facsimile:	+81-3-6871-7672
------------	-----------------	------------	-----------------

### Play It! Amusements, inc.

252 Beinoris Drive, Wood Dale, IL. 60191, USA

Part Sales:	+00 (1) 847-364-9787 ext 102
Tech Support:	+00 (1) 847-364-9787 ext 103/113

### Sega Total Solutions

42 Barwell Business Park, Leatherhead Road, Chessington, Surrey, KT9 2NY. United Kingdom.

Part Sales:	+44 (0) 208 391 8060	Facsimile:	+44 (0) 208 391 8096
-------------	----------------------	------------	----------------------

## Definition of 'Site Maintenance Personnel or Other Qualified Individuals

### WARNING

**Servicing and maintenance work of the contents herein stated should be performed by the SERVICEMAN stipulated as per IEC Standard. Those who do not have technical expertise and knowledge other than the SERVICEMAN are not allowed to perform the work herein stated. Executing aforementioned work by such non-technical personnel can cause serious accidents that may endanger life.**

Parts replacement, maintenance inspections and troubleshooting should be carried out by site maintenance personnel or other qualified professionals. This manual includes directions for potentially dangerous procedures which should only be carried out by professionals with the appropriate specialised knowledge.

The site maintenance personnel or other qualified professionals mentioned in this manual are defined as follows:

#### **Site maintenance personnel:**

Individuals with experience in maintaining amusement equipment, vending machines, etc., working under the supervision of the owner/operator of this product to maintain machines within amusement facilities or similar premises by carrying out everyday procedures such as assembly, maintenance inspections, and replacement of units/expendable parts.

#### **Activities to be carried out by site maintenance personnel:**

Amusement equipment/vending machine assembly, maintenance inspection and replacement of units/expendable parts.

#### **Other qualified professionals:**

Persons employed by amusement equipment manufacturers, or involved in design, production, testing or maintenance of amusement equipment. The individual should have either graduated from technical school or hold similar qualifications in electrical/electronics/mechanical engineering.

#### **Activities to be carried out by other qualified professionals:**

Amusement equipment/vending machine assembly, repair/adjustment of electrical/electronic/mechanical parts.

## SPECIFICATIONS

### Installed Dimensions & Specifications per Cabinet

Machine Dimensions:	1.15m (45.2in.) [Width] x 1.83m (72.5in.) [Depth]	
Machine Height:	2.41m (94.9in.)	
Machine Weight:	330kg (727.5lb) Approx	

Installed Rating:	AC240V - 1.5A	50/60Hz
	AC120V - 3A	50/60Hz
	354W	

## Waste of Electrical and Electronic Equipment (WEEE) Statement.

The WEEE (Waste of Electrical and Electronic Equipment) directive places an obligation on all EU based manufacturers and importers of Electrical and Electronic Equipment to take back products at the end of their useful life. Sega Amusements Europe Ltd accepts its responsibility to finance the cost of treatment and recovery of redundant WEEE in the United Kingdom in accordance with the specified WEEE recycling requirements.

The symbol shown below will be on all products manufactured from 13th August 2005, which indicates this product must NOT be disposed of with other normal waste. Instead, it is the user's responsibility to dispose of their waste equipment by arranging to return it to a designated UK collection point for the correct recycling of waste electrical and electronic equipment.

For more information about where you can send your waste equipment for recycling contact your local authority office.

For non-UK users contact your local authority office for information on the recycling of Waste Electrical and Electronic Equipment.

## Battery Recycling Statement.

The EC Directive on Batteries and Accumulators (2006/66/EC) aims to minimise the impact of batteries on the environment and encourage the recovery of the materials they contain. To achieve increased collection and recycling of waste batteries, the Directive places 'producer responsibility' obligations on manufacturers and importers of portable, industrial and automotive batteries.

The symbol shown below will be on all equipment fitted with batteries from 26th September 2008 and indicates they must NOT be disposed of with other normal waste. Instead, it is the user's responsibility to dispose of used batteries by arranging to return them to a designated collection point for the correct recycling.

For more information about where you can send your waste batteries for recycling contact your local authority office.



REGISTERED IN ENGLAND REGISTERED NO. 1711515

REGISTERED OFFICE: BLOCK C 42 BARWELL BUSINESS PARK, CHESSINGTON, SURREY KT9 2NY

## Photosensitive Epilepsy

### **WARNING**

For about 3 percent of people with epilepsy, exposure to flashing lights at certain intensities or to certain visual patterns can trigger seizures. This condition is known as photosensitive epilepsy. Please be sure to warn players and spectators by applying the Epilepsy warning in the language suitable for point of operation.

At the time of shipment, the factory places an English version of the Epilepsy Warning label near the screen. This provides a place for either the player or spectator to read comfortably.

When shipping the product to a location where English is not the first spoken language, place the epilepsy label for the locations language beside the English version.

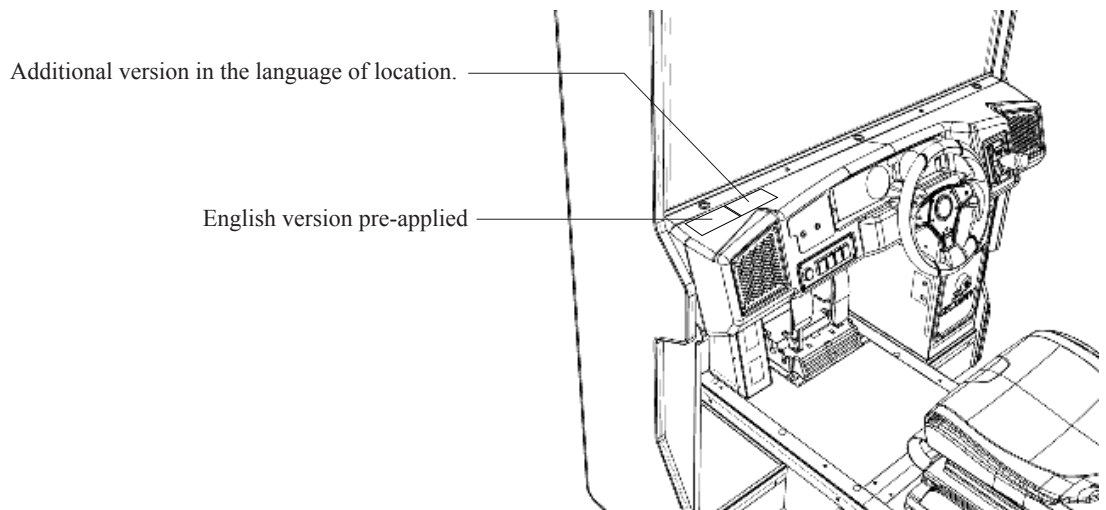

STICKER SHEET C EPILEPSY MULTI

440-CS0186UKUK (1)

Multilingual caution label - epilepsy seizure  
(English version fitted as standard)



# 1 HANDLING PRECAUTIONS

When installing or inspecting the machine, be very careful of the following points and pay attention to ensure that the player can enjoy the game safely.

Non-compliance with the following points or inappropriate handling running counter to the cautionary matters herein stated can cause personal injury or damage to the machine.

## WARNING

- Before performing work, be sure to turn the power off. Performing the work without turning the power off can cause an electric shock or short circuit. In the case work should be performed in the status of power on, this manual always states to that effect.
- To avoid an electric shock or short circuit, do not plug in or unplug quickly.
- To avoid an electric shock, do not plug in or unplug with a wet hand.
- Do not expose power cords or earth wires on the surface, (floor, passage, etc.). If exposed, the power cords and earth wires are susceptible to damage. Damaged cords and wires can cause an electric shock or short circuit.
- To avoid causing a fire or an electric shock, do not put things on or damage the power cords.
- When or after installing the product, do not unnecessarily pull the power cord. If damaged, the power cord can cause a fire or an electric shock.
- In case the power cord is damaged, ask for a replacement through where the product was purchased from or the office herein stated. Using the cord as is damaged can cause fire, an electric shock or leakage.
- Be sure to perform grounding appropriately. Inappropriate grounding can cause an electric shock.
- Be sure to use fuses meeting the specified rating. Using fuses exceeding the specified rating can cause a fire or an electric shock.
- Be sure that connections such as IC BD are made properly. Insufficient insertion can cause an electric shock.
- Specification changes, removal of equipment, conversion and/or addition, not designated by SEGA are not permitted.
  - Failure to observe this may cause a fire or an electric shock. Non-compliance with this instruction can have a bad influence upon physical conditions of the players or the onlookers, or result in injury during play.
  - SEGA shall not be held responsible for damage, compensation for damage to a third party, caused by specification changes not designated by SEGA.
- Do not perform any work or change parts not listed in this manual. Doing so may lead to an accident.

If you need to perform any work not listed in this manual, request work from the office indicated in this manual or the point of purchase, or inquires for details.
- Be sure to perform periodic maintenance inspections herein stated.

## **STOP** IMPORTANT

- For the IC board circuit inspections, only the logic tester is allowed. The use of a multiple-purpose tester is not permitted, so be careful in this regard.
- Static electricity from your body may damage some electronics devices on the IC board. Before handling the IC board, touch a grounded metallic surface so that the static electricity can be discharged.
- Some parts are not designed and manufactured specifically for this game machine. The manufacturers may discontinue, or change the specifications of such general-purpose parts. If this is the case, SEGA cannot repair or replace a failed game machine whether or not a warranty period has expired.

### CONCERNING THE STICKER DISPLAY

This SEGA product has stickers attached describing the product manufacture No. (Serial No.) and Electrical Specifications. It also has a Sticker describing where to contact for repair and for purchasing parts.

When inquiring about or asking for repairs, mention the Serial No. and Name of Machine indicated on the Sticker. The Serial Number indicates the product register. Identical machines could have different parts depending on the date of production. Also, improvements and modifications might have been made after the publication of this manual. In order to ensure you order the correct parts, mention the Serial No. when contacting the applicable places.

### CONCERNING WARNING DISPLAYS

This SEGA product has warning displays on stickers, labels and/or printed instructions adhered/attached to or incorporated in the places where a potentially hazardous situation could arise. The warning displays are intended for accident prevention for customers and for avoiding hazardous situations relating to maintenance and servicing work. Some portions of the cabinet contain high voltage and may cause accidents if touched. When performing maintenance, be very careful of the warning displays. It is especially important that any complex repair and replacement work not mentioned herein should be performed by those technical personnel who have knowledge of electricity and technical expertise. In order to prevent accidents, caution any customer ignoring the warnings to cease and desist immediately.

# CAUTION & WARNING LABEL LOCATIONS

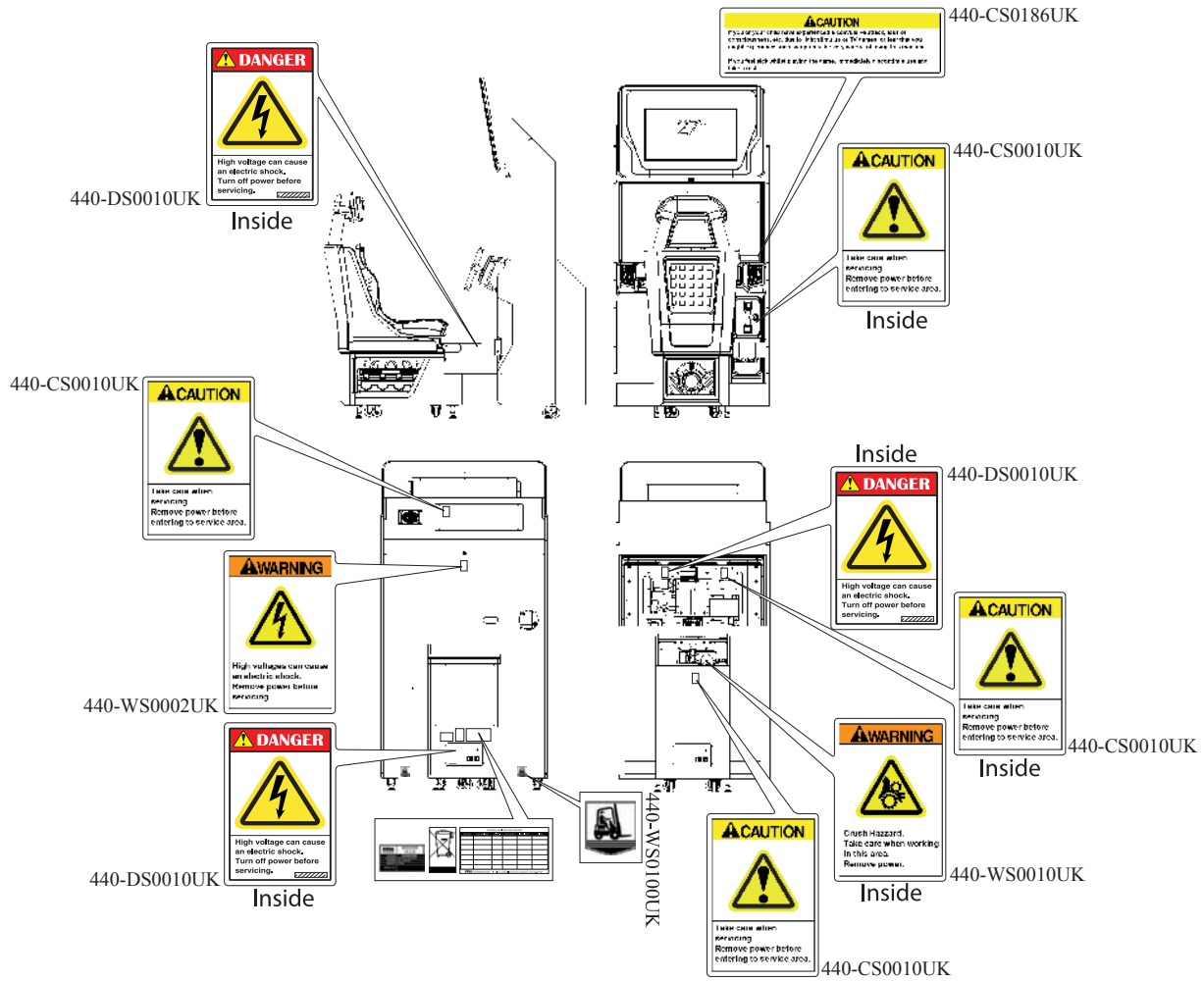

01 fig. 01

## **2** PRECAUTIONS REGARDING INSTALLATION LOCATION

### **WARNING**

This product is an indoor game machine. Do not install it outside. Even indoors, avoid installing in places mentioned below so as not to cause a fire, electric shock, injury and/or malfunction.

- Places subject to rain or water leakage, or places subject to high humidity in the proximity of an indoor swimming pool and/or shower, etc.
- Places subject to direct sunlight, or places subject to high temperatures in the proximity of heating units, etc.
- Places filled with inflammable gas or vicinity of highly inflammable/volatile chemicals or hazardous matter.
- Dusty places.
- Sloped surfaces.
- Places subject to any type of violent impact.
- Vicinity of anti-disaster facilities such as fire exits and fire extinguishers.
- The operating (ambient) temperature range is not from 5°C to 30°C.
- Places near water or spray from water such as a Jet Wash or Swimming Pool.

## 2-1 LIMITATIONS OF USAGE

### WARNING

- Be sure to check the Electrical Specifications. Ensure that this product is compatible with the location's power supply, voltage, and frequency requirements. A plate describing Electrical Specifications is attached to the product. Non-compliance with the Electrical Specifications can cause a fire and electric shock.
- This product requires a breaker and earth mechanism as part of the location facilities. Using the product without these can cause a fire and electric shock.
- Ensure that the indoor wiring for the power supply is rated at 15 A or higher (AC single phase 100 V ~ 120 V area), and 7 A or higher (AC 220 V ~ 240 V area). Non-compliance with the Electrical Specifications can cause a fire and electric shock.
- Be sure that the ring main has a rating of 32A (AC220V ~ 240V area) and
- Be sure to use an independent power supply equipped with an earth leakage breaker. Using a power supply without an earth leakage breaker can cause an outbreak of fire if a power surge occurs.
- Putting many loads on one electrical outlet can cause generation of heat and a fire resulting from overload.
- When using an extension cord, ensure that the cord is rated at 15 A or higher (AC 100 V ~ 120 V area) and 7 A or higher (AC 220 V ~ 240 V area). Using a cord rated lower than the specified rating can cause a fire and electric shock.

## 2-2 OPERATION AREA

**⚠ WARNING**

- For the operation of a single machine, secure a minimum area of 2.1m (82.6in) (W) x 2.3m (90.5in) (D). If the machine rolls during play it could lead to serious injury. You must secure a equal or greater than the space specified in this document.
- Be sure to provide sufficient space specified in this manual. Do not allow objects to block the ventilation ports. It can cause generation of heat and a fire.
- SEGA shall not be held responsible for damage or compensation for damage to a third party, resulting from the failure to observe this instruction.
- If the machine does not fit through the entryway to the installation location, do not disassemble it without first consulting the instructions. If the machine still does not fit through the entryway after following the procedures in this manual, contact your retailer or the office listed in this manual.

**STOP IMPORTANT**

To install this product, the entrance must be at least 1.05 m in width and 2.06 m in height.

Secure an area of no less than 2.1m (82.6in) x 2.3m (90.5in) for operation taking into consideration the safety of the players and spectators of this game.

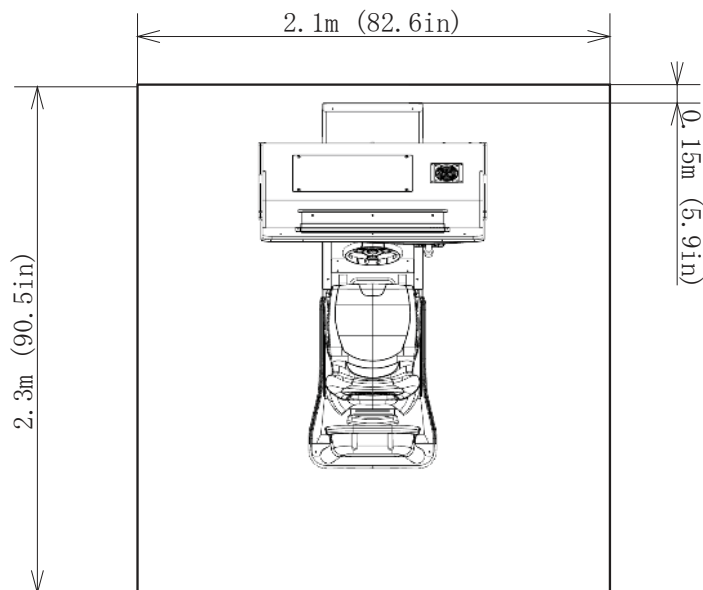

2-2 fig. 01

## 2-3 OPERATION AREA - MULTIPLE CABINETS

### STOP IMPORTANT

Secure an area of no less than 3.3m (129in) x 2.3m (90.5in) for operation of the TWIN cabinet, taking into consideration the safety of the players and spectators of this game.

To install this product, the entrance must be at least 1.05 m in width and 2.06 m in height.

When installing multiple cabinets, make sure the rules are followed below.

1. Keep a distance of no greater than 5mm (3/16in) between each Monitor Cabinet.
2. Keep a distance of a minimum of 0.5m either side of the end cabinets.
3. Keep a minimum distance of 0.15m at the rear of the cabinet for ventilation.

#### Two cabinet formation. (Twin)

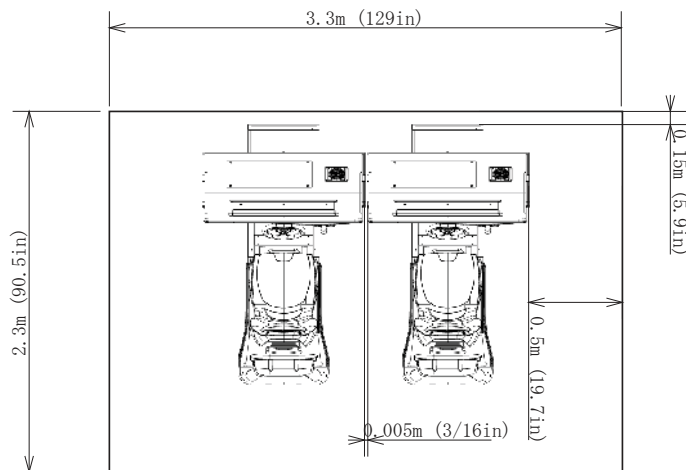

2-2 fig. 02

#### Four cabinet formation.

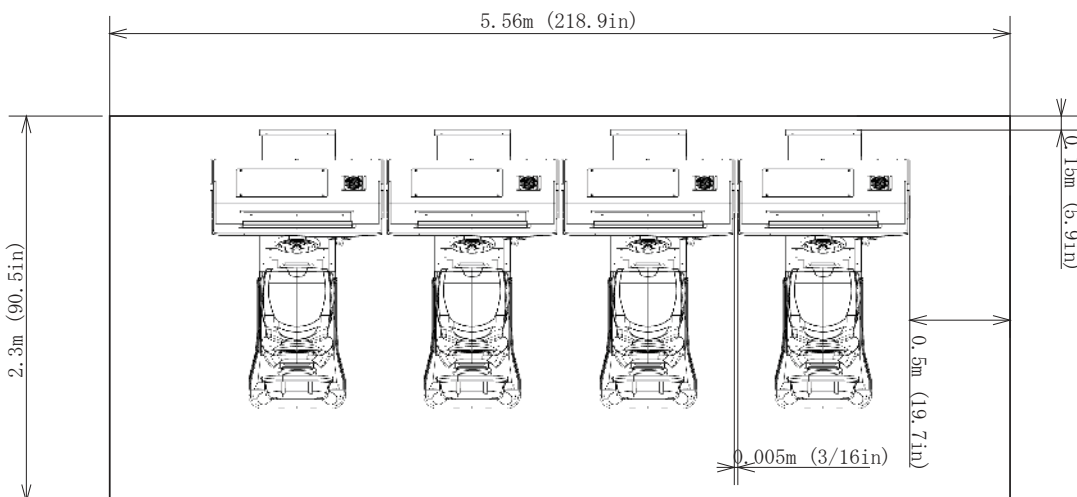

2-2 fig. 03

**Eight cabinet formation.**

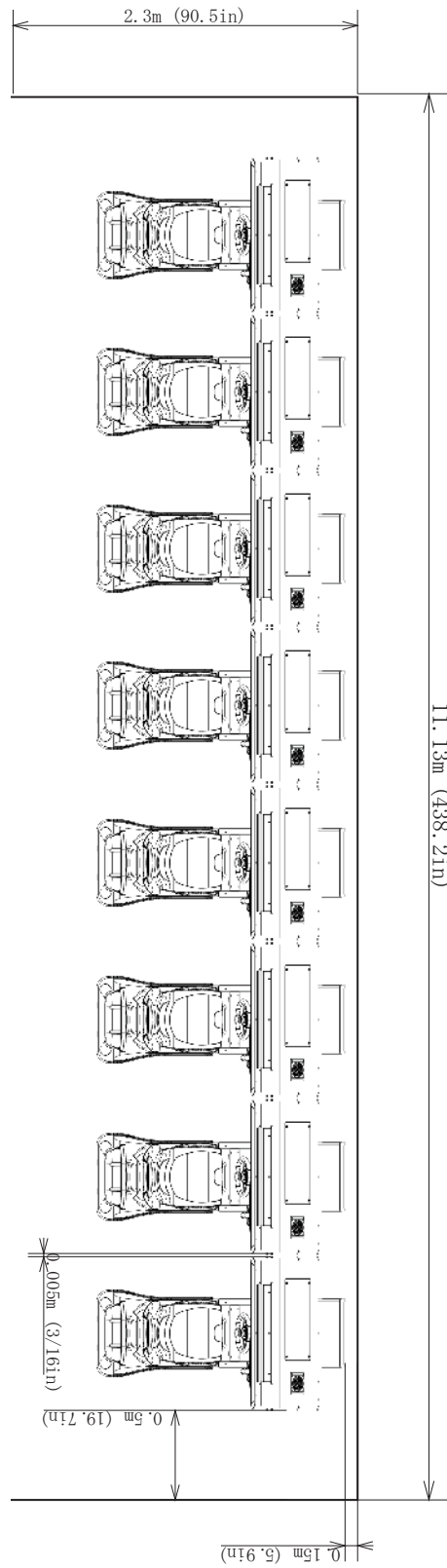

**2-2 fig. 04**

### 3 PRECAUTIONS REGARDING PRODUCT OPERATION

To avoid injury and trouble, be sure to pay attention to the behavior of visitors and players.

#### 3-1 BEFORE OPERATION

##### WARNING

In order to avoid accidents, check the following before starting the operation:

- To ensure maximum safety for the players and the customers, ensure that where the product is operated has sufficient lighting to allow any warnings to be read. Operation under insufficient lighting can cause bodily contact with each other, hitting accident, and/or trouble between customers.
- Be sure to perform appropriate adjustment of the monitor. For operation of this machine, do not leave monitor's flickering or deviation as is. Failure to observe this can have a bad influence upon the players' or the customers' physical conditions.
- It is suggested to ensure a space allowing the players who feel sick while playing the game to take a rest.
- Check if all of the adjusters are in contact with the surface. If they are not, the Cabinet can move and cause an accident.

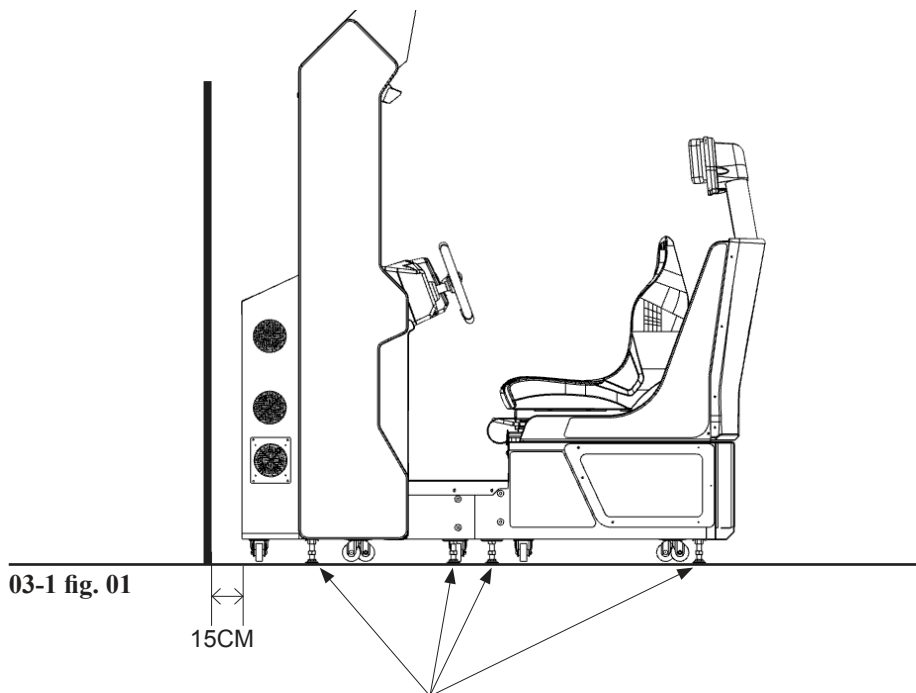

Ensure that all of the 8 adjusters are in contact with the floor.  
Provide a gap at the back of the cabinet of no less than 15cm.

### ⚠ WARNING

- Do not put any heavy item on this product. Placing any heavy item on the product can cause a falling down accident or parts damage.
- Do not climb on the product. Climbing on the product can cause falling down accidents. To check the top portion of the product, use a step ladder.
- When using a stepladder or stool while working, do not hold onto the billboard by any electrical components. Hold the Billboard in these areas may cause damage, electronic component failure or personal safety issues.
- To avoid electric shock, check to see if door & cover parts are damaged or omitted.
- To avoid electric shock, short circuit and/or parts damage, do not put the following items on or in the periphery of the product.

[Flower vases, flowerpots, cups, water tanks, cosmetics, and receptacles/containers/vessels containing chemicals and water.]

### ⚠ CAUTION

- To avoid injury, be sure to provide sufficient space by considering the crowd situation at the installation location. Insufficient installation space can cause customers to bump into each other, causing trouble.
- Every day when cleaning the Control (Steering Wheel), inspect the hoop and buttons and make sure that there are no scratches or cracks in the surface, and that the fastening screws are not loose. If the game is played with scratches, cracks or loose screws, it can cause injuries to the player or to people nearby.

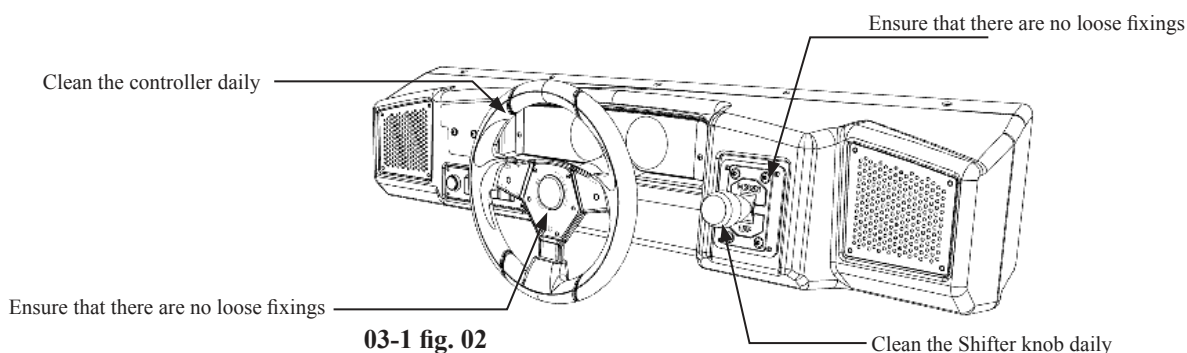

- When you clean the cabinet each day, always make sure that there is nothing placed on the seats and that they are not damp or wet.

### STOP IMPORTANT

To ensure customers enjoy playing the game, clean the Control Unit regularly. If there is any dirt buildup, the hoop may become slippery or tacky resulting in an unpleasant experience for the player.

## DURING OPERATION (PATRON CONDUCT)

To avoid injury and unacceptable behavior, be sure to constantly give careful attention to the behavior and manner of the spectators and players alike..

### WARNING

To avoid injury and accidents, those who fall under the following categories are not allowed to play the game.

- Those who need assistance such as the use of an apparatus when walking.
- Those who have high blood pressure or a heart problem.
- Those who have experienced muscle convulsion or loss of consciousness when playing video game, etc.
- Those who have a trouble in the neck and or spinal cord.
- Intoxicated persons.
- Pregnant women or those who are in the likelihood of pregnancy.
- Persons susceptible to motion sickness.
- Persons whose act runs counter to the product's warning displays.

A player who has never been adversely affected by light stimulus might experience dizziness or headache depending on his physical condition when playing the game.

Instruct those who feel sick during play to have a medical examination.

To avoid injury resulting from falling down and electric shock due to spilled drinks, instruct the player not to place heavy items or drinks on the product.

To avoid electric shock and short circuit, do not allow patrons to put hands and fingers or extraneous matter in the openings of the product or small openings in or around the doors.

To avoid injury resulting from falling down, immediately stop patron's leaning against or climbing on the product, etc.

To avoid electric shock and short circuit, do not allow patrons to unplug the power plug without a justifiable reason.

Players should be warned not to place children on their lap whilst playing the game. Doing so may cause the child or part of the child to become trapped within the working of the machine. i.e. Controller, Seat, Pedals.

Never have more than 1 player playing the game at any one time. Having two or more people playing this game at the same time may result in injuries.

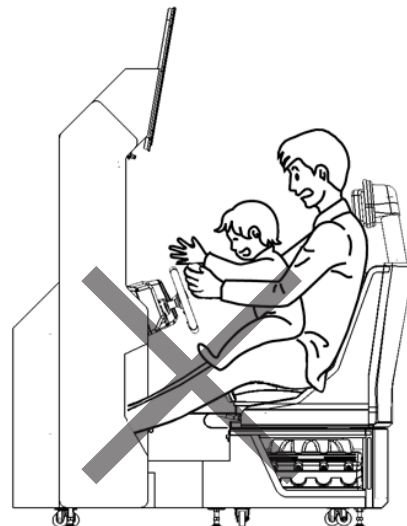

03-1 fig. 03

## 3-2 DURING OPERATION (PAYING ATTENTION TO CUSTOMERS)

To avoid injury and trouble, be sure to pay attention to the behavior of visitors and players.

### **WARNING**

- For safety reasons, do not allow any of the following people to play the game.
  - Those who require supporting devices, etc., to walk.
  - Those who have high blood pressure or a heart problem.
  - Those who have experienced muscle convulsion or loss of consciousness when playing video games, etc.
  - Those who have neck or spinal cord problems.
  - Intoxicated persons.
  - Pregnant women.
  - Persons susceptible to motion sickness.
  - Persons who disregard the product's warning displays.
- Even players who have never been adversely affected by light stimulus might experience dizziness or headache depending on their physical condition when playing the game. Small children are especially likely to experience these symptoms. Caution guardians of small children to keep watch on their children during play.
- Instruct those who feel sick during play to have a medical examination.
- To avoid injury from falls and electric shocks due to spilled drinks, instruct the player not to place heavy items or drinks on the product.
- To avoid electric shocks and short circuits, do not allow customers to put hands and fingers or extraneous matter in the openings of the product or small openings in or around the doors.
- To avoid falls and resulting injury, stop the customer from leaning against or climbing on the product, etc.
- To avoid electric shock and short circuit, do not allow customers to unplug the power plug without a justifiable reason.

## **⚠ CAUTION**

- Immediately stop such violent acts as hitting and kicking the product. Such violent acts can cause parts damage or falling down, resulting in injury due to fragments and falling down.
- Two or more players must never be allowed to play using a single Control Unit. Playing in such a way could lead to physical injuries.
- Players should be warned not to place personal effects or other objects on the base of the machine. If the safety sensor fails to detect these items, the motion of the machine may cause them to fly out and strike other patrons.
- Players should be instructed to adjust the seat by moving it forward or backward to fit their body size before playing the game. Playing the game in an unnatural position can lead to unforeseen accidents.
- Persons other than the player should not be allowed to touch the controls during play. They may brush against or collide with the controls or the player, possibly resulting in accidents.
- Player should be informed/instructed to consider their environment before adjusting the seat.

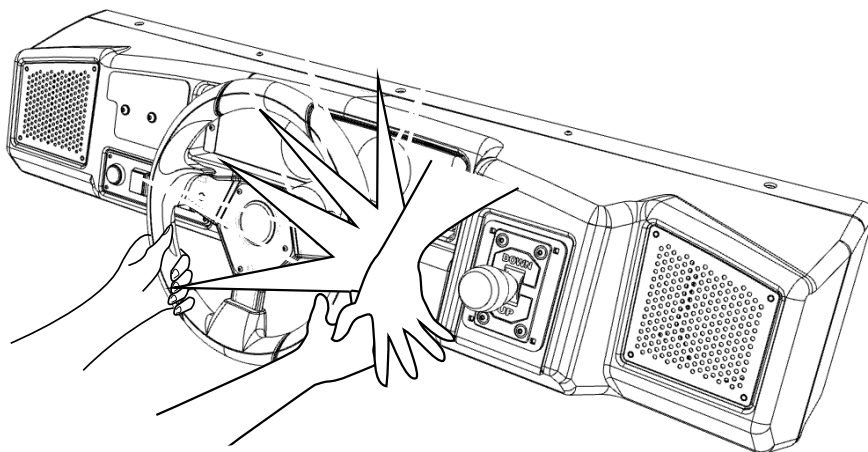

03-2 fig. 01

# 4 PARTS DESCRIPTION

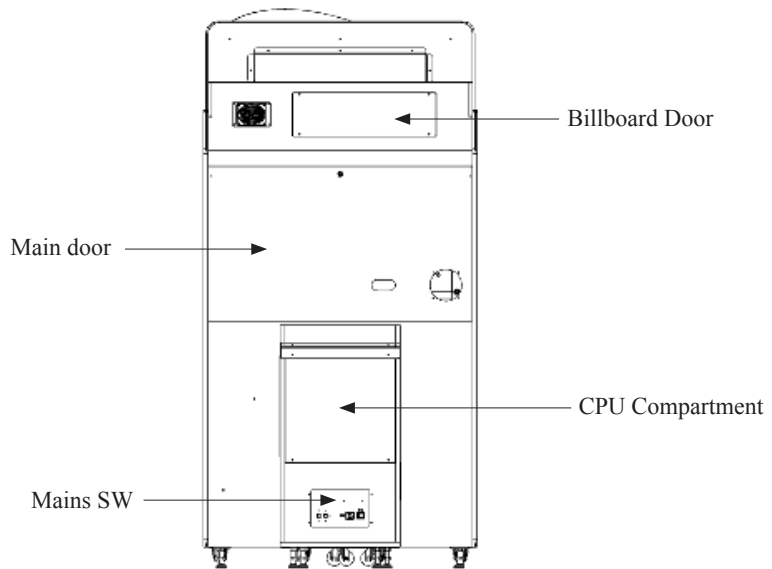
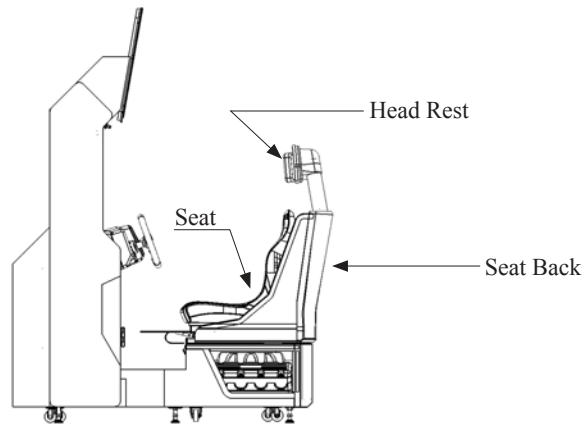
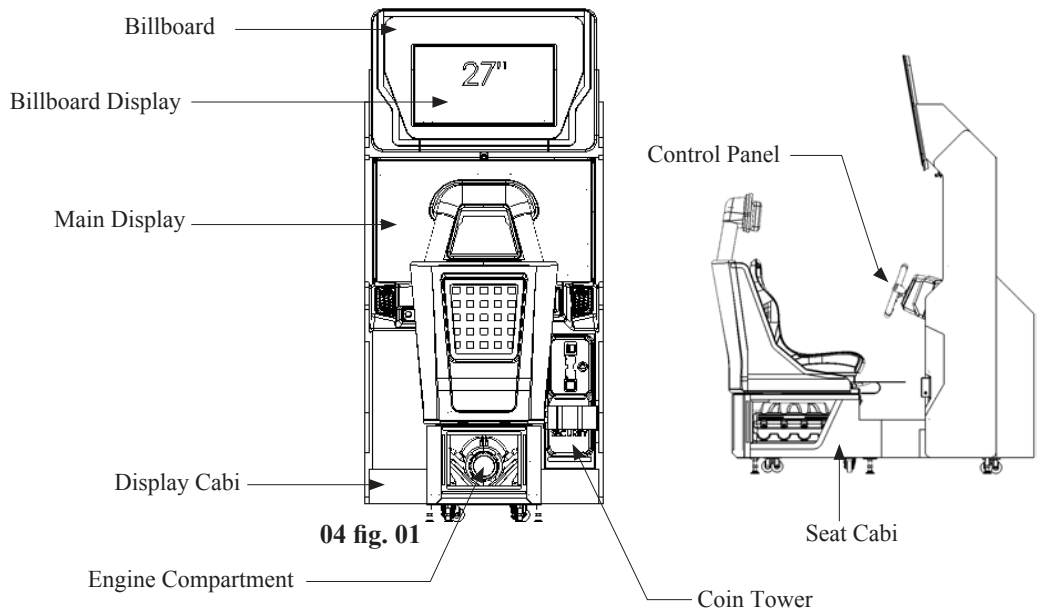

## 5 ACCESSORIES

Confirm that the accessories listed on this page are present when setting up the product.  
Accessories marked “Spare” in the note column are consumable items but included as spares.

### OWNER’S and SERVICE MANUAL

420-0023-01UK (1)

This manual

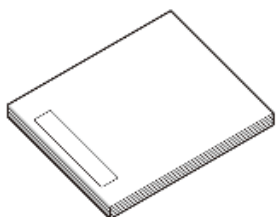

05 fig. 01

### POWER CABLE

LM1227 (1) <UK>

LM1246 (1) <European>

LM1550 (1) <America>

For installation, see chapter 6

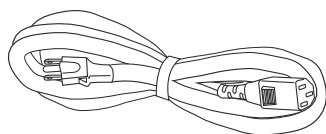

05 fig. 02

### KEY

(2)

For the cashbox door  
(Attached to the Steering Wheel  
at time of shipment)

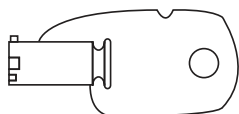

05 fig. 03

### MASTER KEY

220-5575UK (4)

For opening/closing the doors  
(Packaged with this manual, in the box supplied with  
the product)

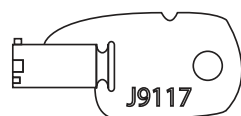

05 fig. 04

### STICKER SHEET C EPILEPSY MULTI

440-CS0186UKUK (1)

Multilingual caution label - epilepsy seizure  
(English version fitted as standard)

*Please see “Introduction” section of this manual for  
label positioning.*



05 fig. 05

### Network (Lan) Cable

(2m)

For linking a twinned cabinet for  
network play.

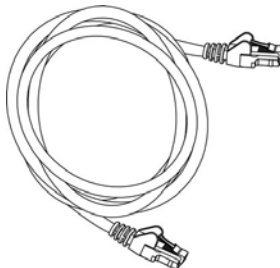

05 fig. 06

The parts listed in Table 5b are needed to finalise the installation. These are traditionally parts that are applied by the customer at location. Please take a moment to check the contents. If for some reason some the parts are not present then please call your local office along with the machine serial number to arrange for the relevant parts to be sent to you. (PLEASE NOTE THAT SOME ITEMS ARE ALREADY FITTED TO LOCATION TO AID INSTALL)

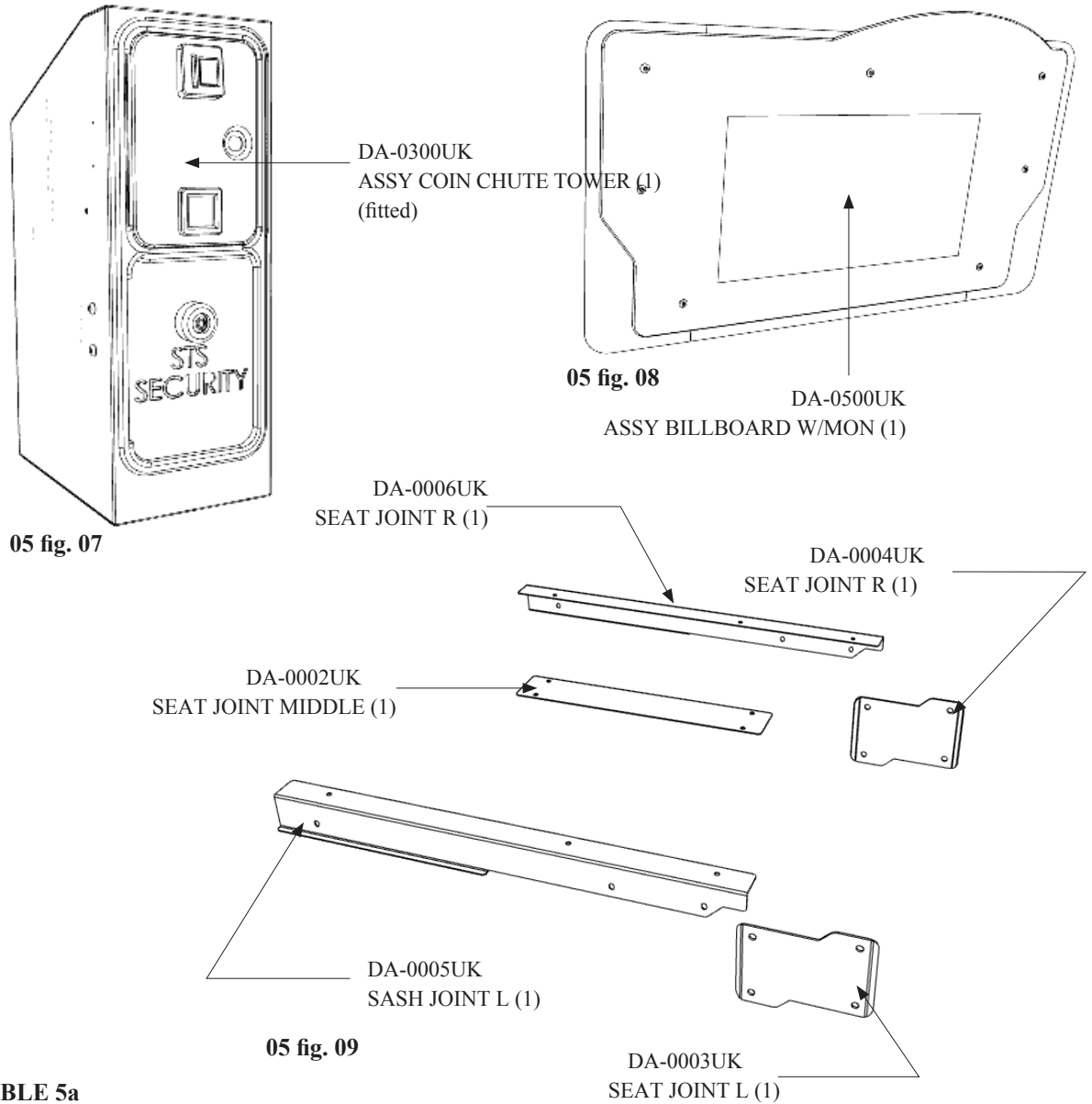

TABLE 5a

Qty	PART NUMBER	DESCRIPTION	QTY
**1	DA-0300UK	ASSY COIN CHUTE TOWER (fitted)	1
**2	DA-0500UK	ASSY BILLBOARD W/MON	1
**3	DA-0002UK	SASH JOINT MID	1
**4	DA-0003UK	BRKT JOINT INNER L	1
**5	DA-0004UK	BRKT JOINT INNER R	1
**6	DA-0005UK	SASH JOINT L	1
**7	DA-0006UK	SASH JOINT R	1
**201	029-B00840-0B	M8X40 SKT BH BLK	5
**202	060-S00800-0B	M8 WSHR SPR BLK	11
**203	068-852216-0B	M8 WSHR 22OD FLT BLK	11
**204	050-U00800	M8 NUT NYLOK PAS	2
**205	029-B00616-0B	M6X16 SKT BH BLK	5
**206	060-S00600-0B	M6 WSHR SPR BLK	5
**207	068-652016-0B	M6 WSHR 20OD FLT BLK	5
**208	029-B00425	M4X25 SKT BH PAS	16
**209	068-441616	M4 WSHR 16OD FLT PAS	16
**210	029-B00850-0B	M8X50 SKT BH BLK	8

## 6 ASSEMBLY AND INSTALLATION

### WARNING

- Perform assembly work by following the procedure herein stated. Failure to comply with the instructions can cause electric shock.
- Perform assembling as per this manual. Since this is a complex machine, incorrect assembling can cause an electric shock, machine damage and/or improper functioning as per specified performance.
- When assembling, more than one person is required. Depending on the assembly work, there are some cases in which working by one person alone can cause personal injury or parts damage.
- Ensure that connectors are properly connected. Improper connections can cause electric shock.
- Be careful not to damage the wires. Damaged wires may cause electric shock or short circuit or present a risk of fire.
- This work should be carried out by site maintenance personnel or other qualified professionals. Work performed by non-technical personnel can cause a severe accident such as electric shock. Failing to comply with this instruction can cause a severe accident such as electric shock to the player during operation. If no one with proper technological expertise is available, request service from the office indicated in this document or the point of purchase so as to ensure safety.
- Provide sufficient space so that assembling can be performed. Performing work in places with narrow space or low ceiling may cause an accident and assembly work to be difficult.
- To perform work safely and avoid serious accident such as the cabinet falling down, do not perform work in places where step-like grade differences, a ditch, or slope exist.
- Do not leave power cords or ground wires exposed in areas of heavy foot traffic. Doing so may cause them to become damaged, possibly resulting in electric shock and/or short circuits. When laying wiring across the floor, always use safety covers to protect the wires. (Wiring diameter: power cable - approx.  $\varnothing$  8)
- Have a flashlight or another supplementary lighting unit available while working. With indoor lighting alone, the cabinet interior may be too dark. Working without proper lighting can lead to accidents. It also hinders proper work performance.
- The cabinet has ventilation ports. Be sure not to block them. If they are blocked, heat can build up, leading to fire. This can also accelerate wearing of parts and malfunctions.
- Secure ample ventilation space around the cabinet. If heat builds up, there could be accidents associated with heat or smoke generation.
- This product does not use any connectors other than those connected to and used by the game board when it leaves the factory. Do not needlessly connect wires to unused connectors. This could lead to overheating, generation of smoke and burn related injuries.

**⚠ CAUTION**

- Handle molded parts with care. Excessive weight or pressure may cause them to break and the broken pieces may cause injury.
- To perform the operation safely and accurately you must use a safe, steady footstool or stepladder. Working without this may lead to a fall and possible injury.
- Attempting to forcefully connect the incorrect connector or connecting a connector at the wrong angle or facing may damage the connector and could lead to overheating and burn related injuries.
- When attaching or removing doors or lids, be careful that your hand or finger does not get caught in anything.

**STOP IMPORTANT**

- Be very careful when handling LCD screen. The screen can be damaged easily and cannot be repaired once damaged. Such damage can only be repaired by completely replacing the screen.
- Be careful not to damage parts surfaces. In some cases, if such surfaces are damaged, the part must be replaced; it cannot be reinforced or repaired.

The assembly of this product is performed in the following 12 steps.

- 6.1 UNPACKING THE CABINET.
- 6.2 ATTACHING THE BILLBOARD WITH MONITOR.
- 6.3 JOINING THE CABINETS.
- 6.4 INSTALLING MULTIPLE CABINETS
- 6.5 LINKING THE CABINETS (COMMUNICATION).
- 6.6 APPLYING THE POWER

## Tools Required for Assembly Operation

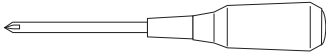

- Philips screwdriver (for M4, M6 screws)

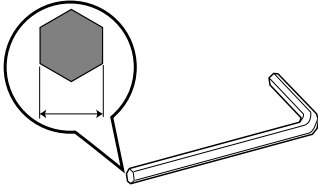

- Hex Drive for (M4, M6 & M8 screws)

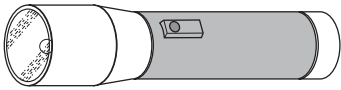

- A torch or any additional lighting

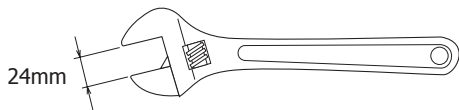

- A wrench or 24mm Spanner.



- Machine Keys (Supplied)

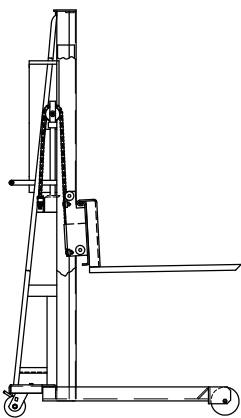

- Lifting equipment capable of lifting a weight of 250kg

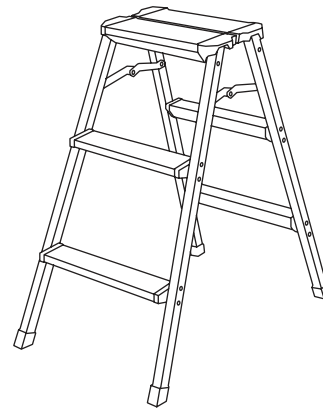

Locking Step Ladders -

## 6-1 UNPACKING THE CABINETS

### STOP IMPORTANT

- Be very careful when removing the Monitor and Seat cabinets from the pallet. Use only hydraulics lifting equipment such as a fork lift. Some parts weigh in excess of 200Kgs. DO NOT attempt to remove the machine from the pallet by hand. Doing so may result in serious personal injury and/or damage to the cabinet and its components.
- There are 2 "LIFTING POINTS" highlighted on the lower front and rear parts of the machine by a  symbol. Always use these points when lifting.

#### Display Cabinet

This product is delivered as 3 individual components. 2 x Pallets for the two ASSY DISPLAY CABINETS and a single pallet for both ASSY SEATS. Take care when removing the machine from it's pallet. Only use appropriate lifting equipment such as a Fork Truck or similar lifting equipment. DO NOT attempt to remove by hand. Removing this product from its pallet by hand can cause severe injury and/or damage to the product and surrounding area.

The plastic outer covering is specially designed to fix the cabinet to the pallet. Once the plastic covering is removed, the machine will no longer be held securely to the pallet.

Remove the cabinet from it's pallet by approaching it from the rear. Using lifting equipment, carefully lift the machine up enough so that the pallet can be dragged from beneath it.

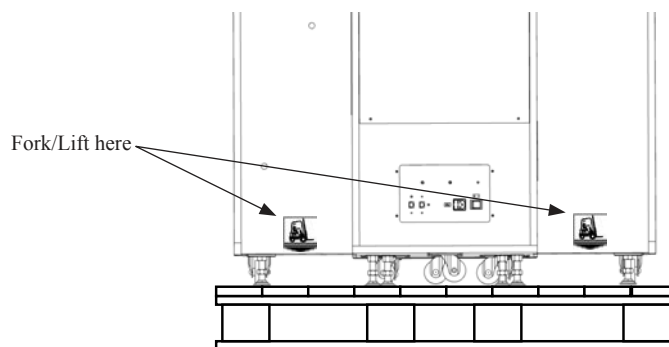

6-1 fig. 01

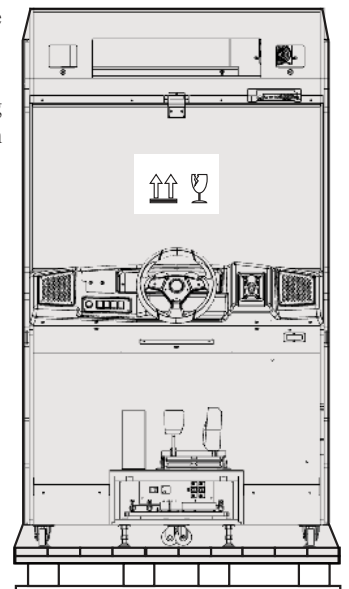

6-1 fig. 02

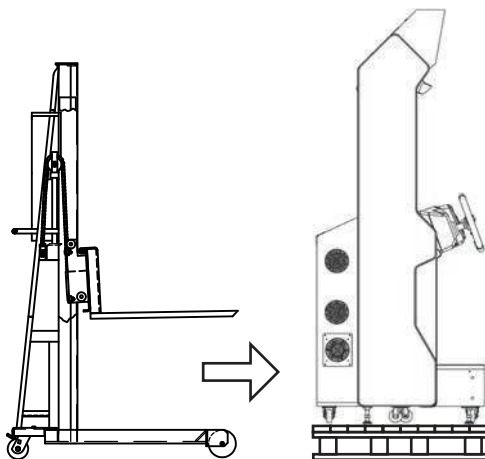

6-1 fig. 03

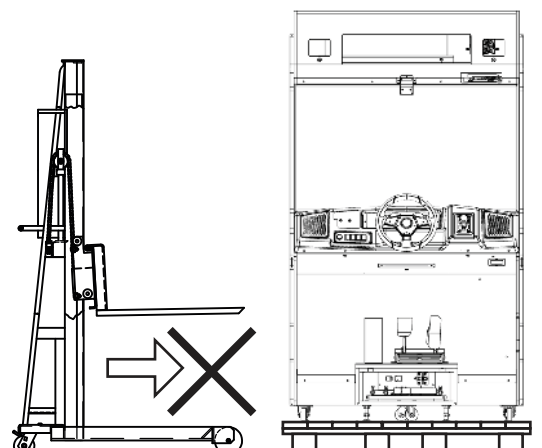

6-1 fig. 04

## Seat Cabinet

The ASSY SEAT CABI are packed as pairs along with the INSTALLATION KIT. Like the DISPLAY CABI, the ASSY SEAT CABI's are attached to the pallet by means of a strong clear bag which is shrunk down to fit the contents within. Using a blade or scissors, carefully cut away the bag, from around the top edge of the pallet, taking care not to damage its contents.

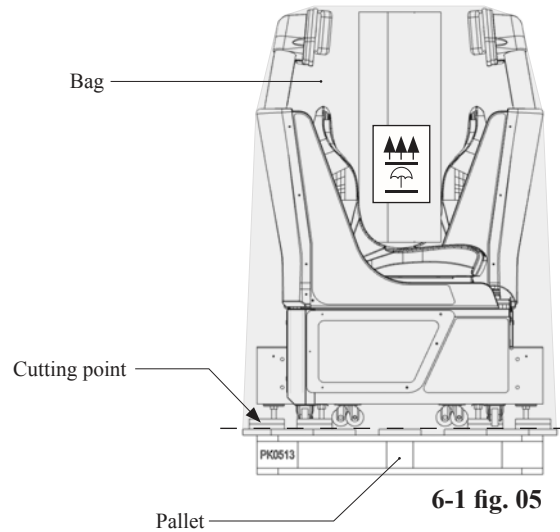

Using (2) people, carefully lift and remove the INSTALLATION KIT which rests across the top of the SEATS. DO NOT attempt to remove the INSTALLATION KIT single-handedly. Removing the Installation Kit single-handedly may result in either damage to components and/or personal injury.

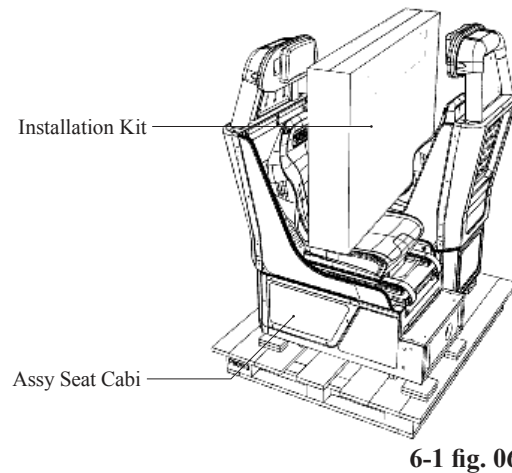

Remove the ASSY SEATS from the pallet using adequate lifting equipment. Failing to use such equipment may result in damage to components or personal injury.

 HEAVY!

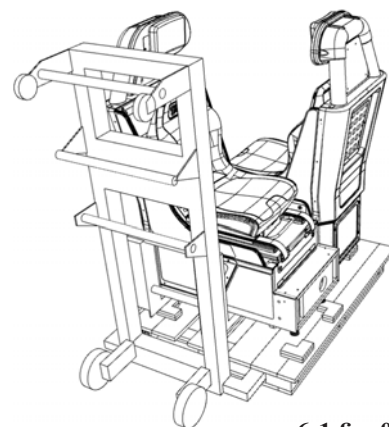

6-1 fig. 07

### Installation components

Carefully unpack and check the contents of the INSTALLATION BOX. If any of the contents are missing or damaged then please contact you nearest SEGA office or Distributor as soon as possible. Contact numbers are found in the Introduction section of this manual.

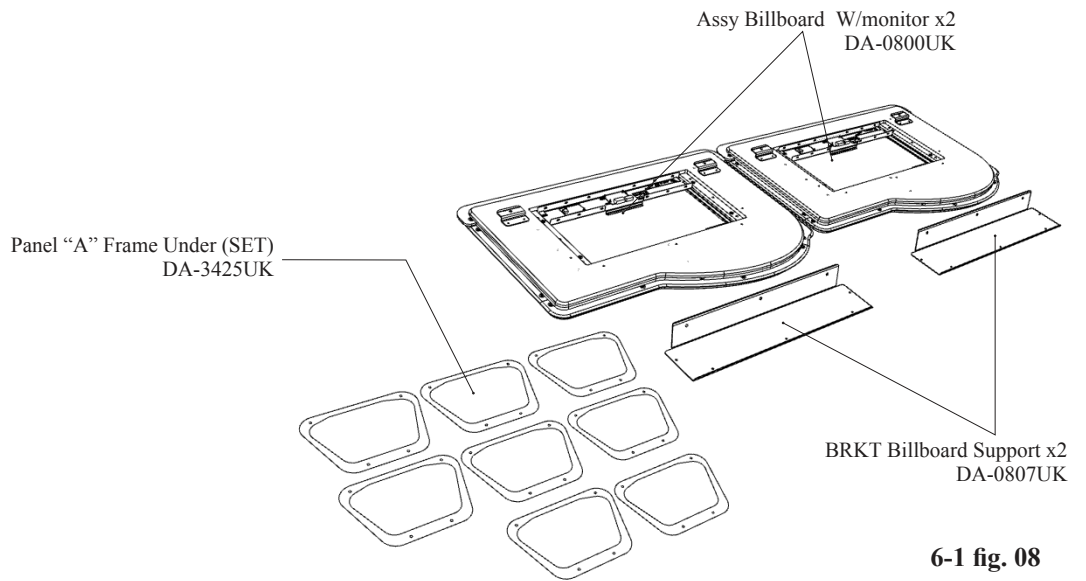

The remaining components required for installation are located within the footwell of the display cabinet. This Manual, Power leads and Network cables are found in the Cash Box

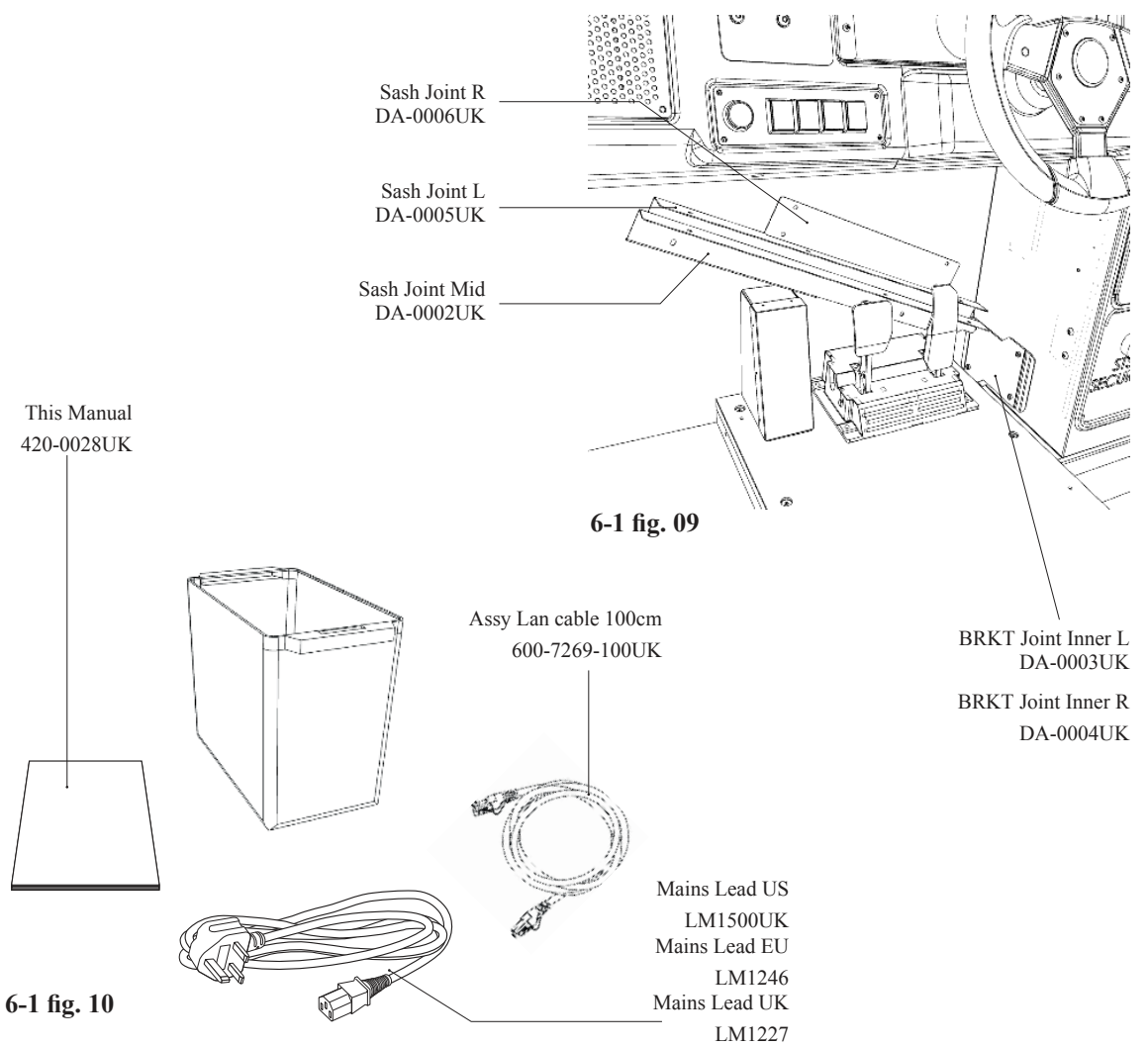

## 6-2 ATTACHING THE BILLBOARD W/MONITOR

### CAUTION

- Handle molded parts with care. Excessive weight or pressure may cause them to break and the broken pieces may cause injury.
- Some aspects of this operation may require two people to ensure that the work is carried out safely. Do not begin to carry out this work if no more than one person is available.
- When working at height, always use either a stool or stepladder. Have another person stabilise the equipment before stepping onto it to begin the work. Failure to secure either ladders or stool may cause in an accident and result in injury and/or damage to the machine.

Make sure you provide enough space to work safely. Please refer to the “Installation Precautions” section found earlier in this manual. Take care when unpacking the ASSY BILLBOARD. There are fragile components attached to the base and framework.

- 1 Remove the (5) M4x16 fixings which are fitted in situ for transit. Fit the SUPPORT BRKT (DA-0807UK) into location and secure using the (5) M4x16 fixings previously removed.

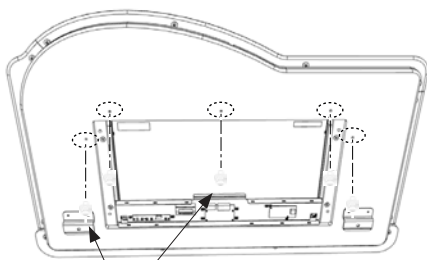
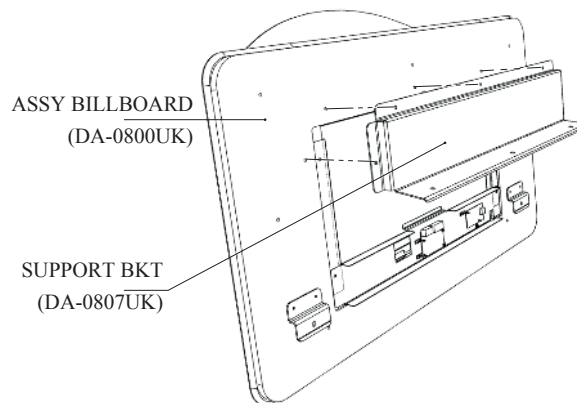

FIG. 6-2a

M4X16 SKT BH PAS (5)  
(029-B00416)

M4 WSHR 16OD FLT PAS (5)  
(068-441616)



6-2 fig. 01

- 2 Remove the M4x30 Pozi Machine Screws from the upper door on the ASSY MONITOR CABI.

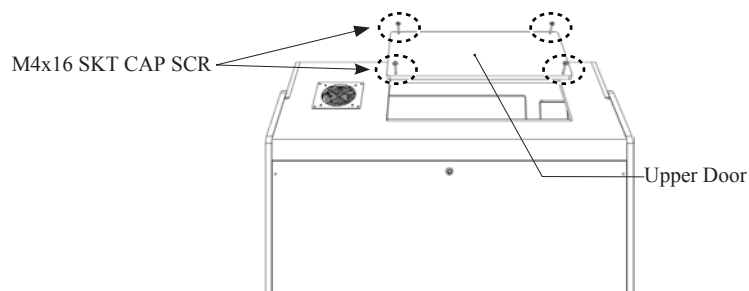

6-2 fig. 03

**3** Locate and remove the (5) M6 SOCKET CAP BOLTS and WASHERS.

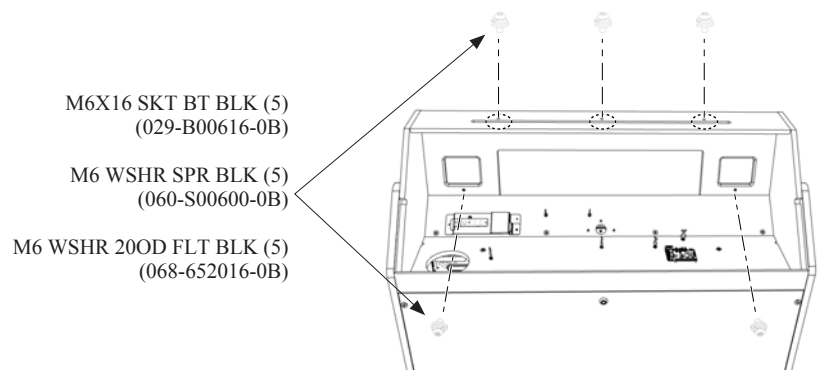

6-2 fig. 04

**4** Using 2 people, carefully raise the ASSY BILLBOARD into position. For safety, use a step or ladders to prevent over reaching. Take care not to trap any wires when offering the Billboard to the cabinet.

**!** HEAVY!

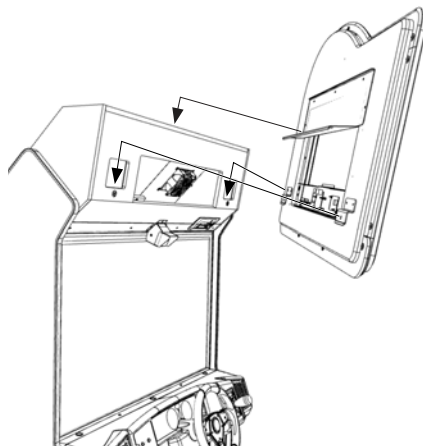

6-2 fig. 05

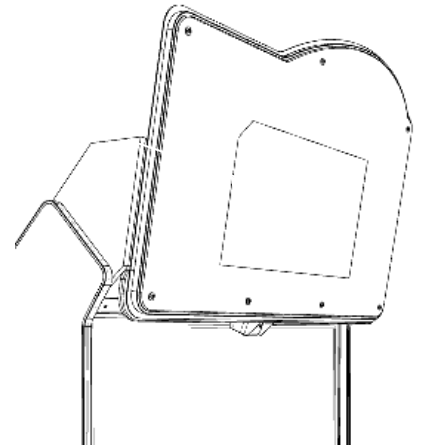

6-2 fig. 06

**5** Once the ASSY BILLBOARD is latched in place. Secure from the top and rear using the (5) M6 SOCKET CAP BOLTS removed from Step 3.

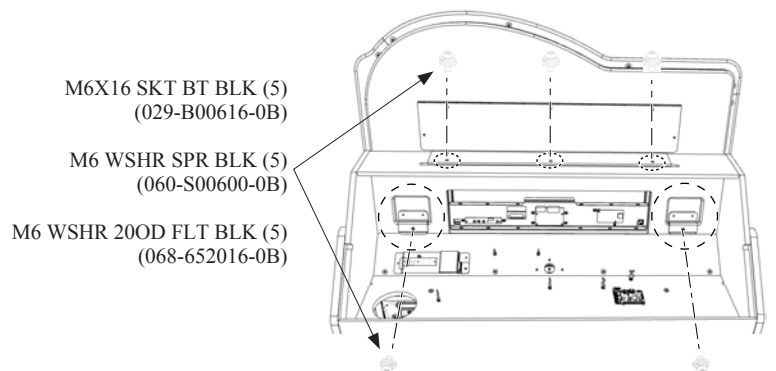

6-2 fig. 07

**6** Connect the Harnesses. 1x Monitor PWR, 1x Monitor DVI, 1x Serial LED, 1x LED PWR.

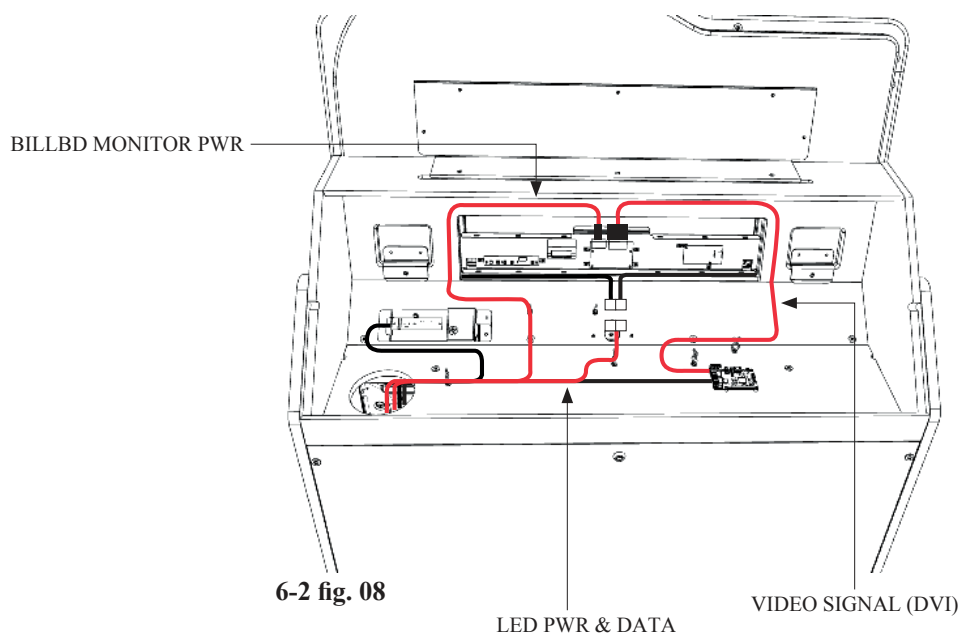

**7** Once all harnesses have been connected and made secure within their routers. Fix down the upper Door removed from Step 2.

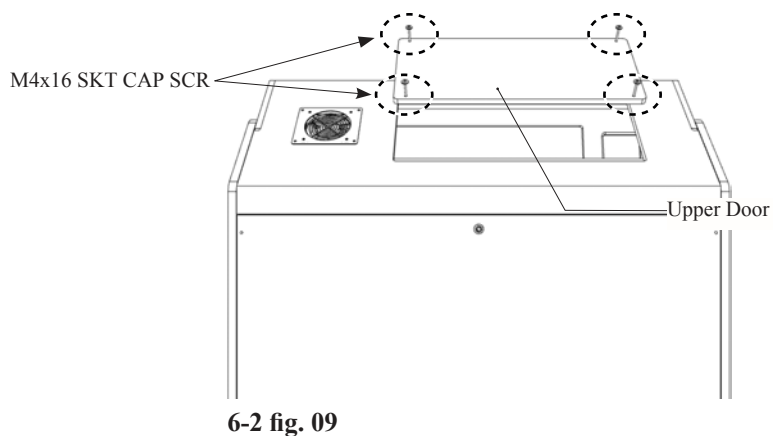

## 6-3 JOINING THE CABINETS

It is important that a suitable location is secured to enable installation to be carried out safely.  
*Please refer the beginning of this manual for Operational Area.*

- 1 Making sure that the castors come into contact with the floor, carefully place and align both front and rear cabinets into position. Follow the guidelines in the OPERATIONAL AREA in the beginning of this manual.

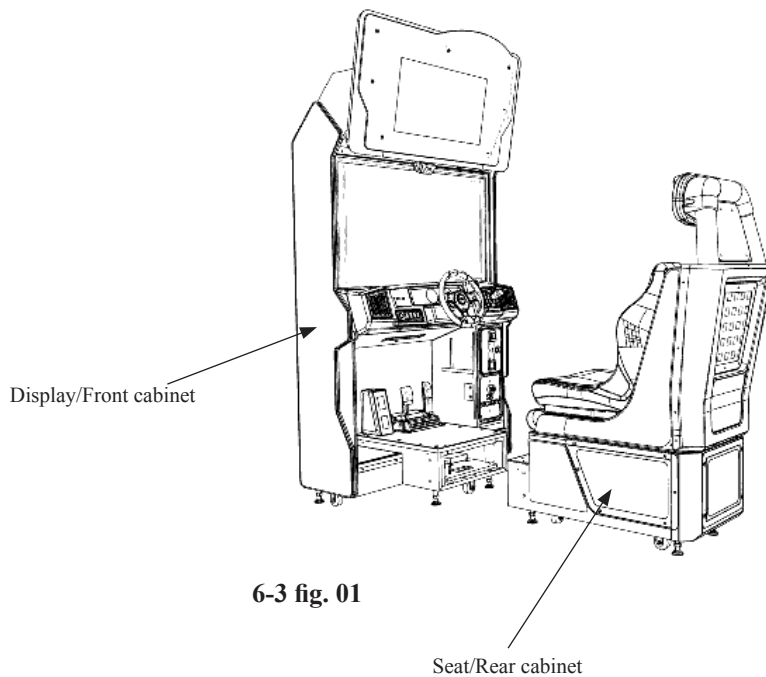

6-3 fig. 01

- 2 Locate and remove the (8) M8X50 fixings fitted to the (2) JOINT BKTS. At the Display Cabinet, place and fit the (2) INNER JOINT BKTS (DA-0003UK & DA-0004UK) into the positions shown, taking note of the orientation. Secure using the M8x50 SKT BH PAS and WASHERS.

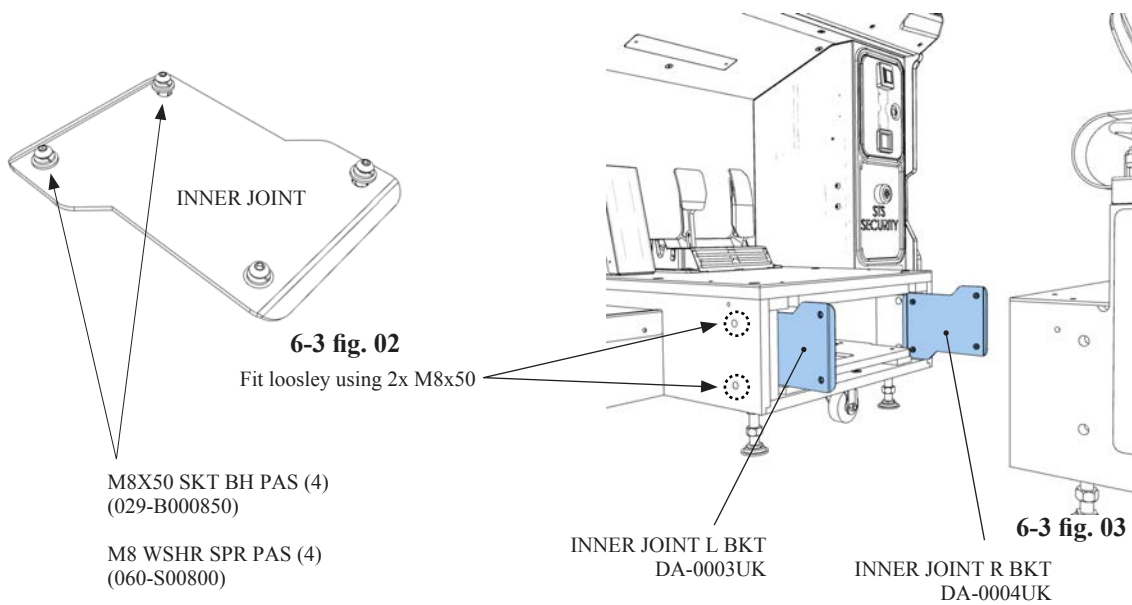

6-3 fig. 02  
 Fit loosley using 2x M8x50

6-3 fig. 03

M8X50 SKT BH PAS (4)  
 (029-B000850)

M8 WSHR SPR PAS (4)  
 (060-S00800)

M8 WSHR 22OD FLT PAS (4)  
 (068-852216)

INNER JOINT L BKT  
 DA-0003UK

INNER JOINT R BKT  
 DA-0004UK

It is important that care is taken when joining the two cabinets together. Take care as not to trap any wires.

- 1 Connect the harnesses between the Assy Seat Cabi and the Assy Monitor Cabi.

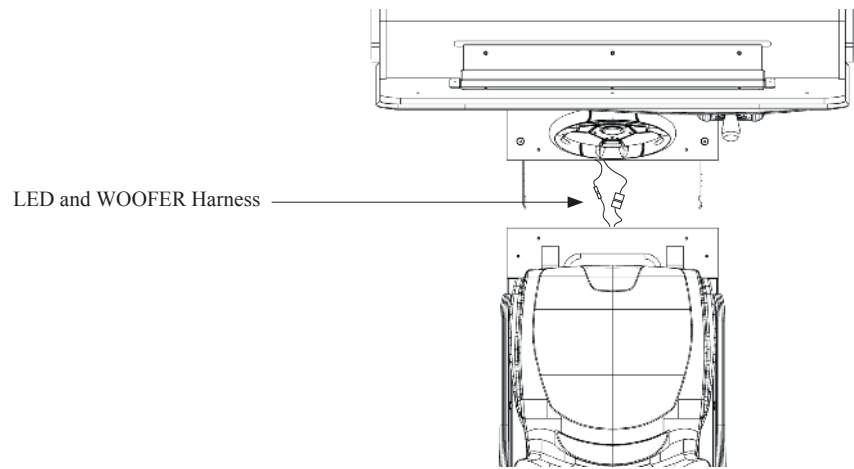

- 4 Carefully push the ASSY SEAT CABI up towards the ASSY DISPLAY CABI taking care not to trap any harnesses.

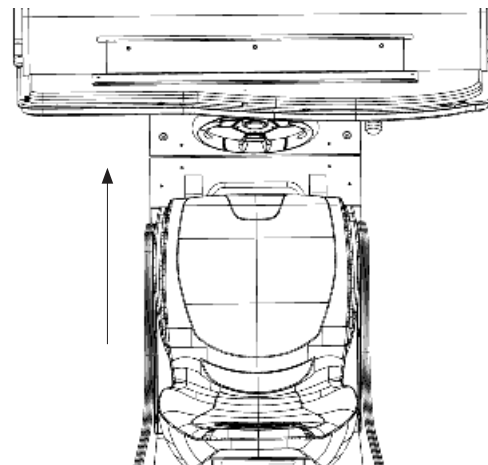
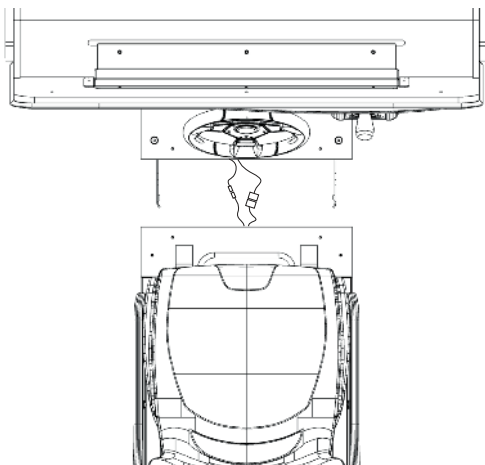

- 5 Using the 2 sets of (4) M8 fixings removed from Step 2. Fit and secure the Assy Seat Cabi to the Assy Monitor Cabi from both sides.

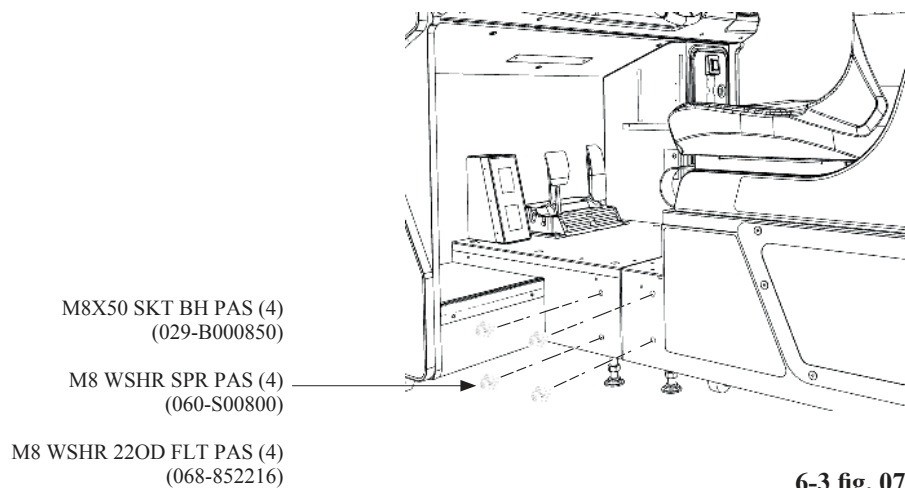

- 6** Remove the (7) M4x25 BUTTON HD machine screws from around the edges of the footwell. There are 14 in total (7 left side and 7 right side).

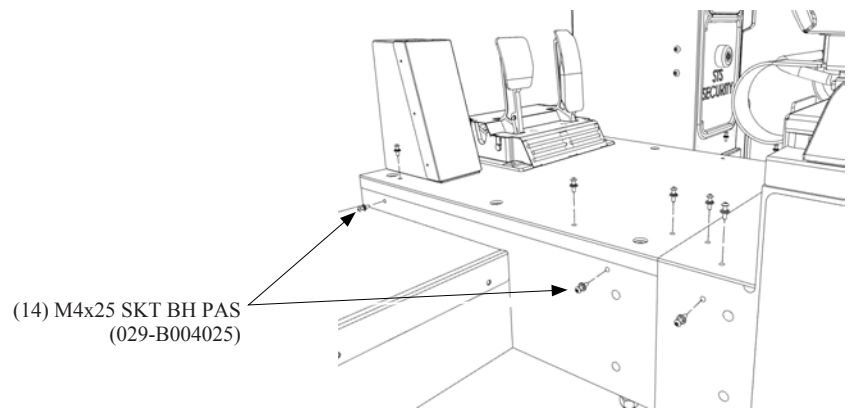

**6-3 fig. 08**

- 7** Place both SASH JOINT L and SASH JOINT R into position and secure using the 10 fixings (5 each side) removed from Step 6.

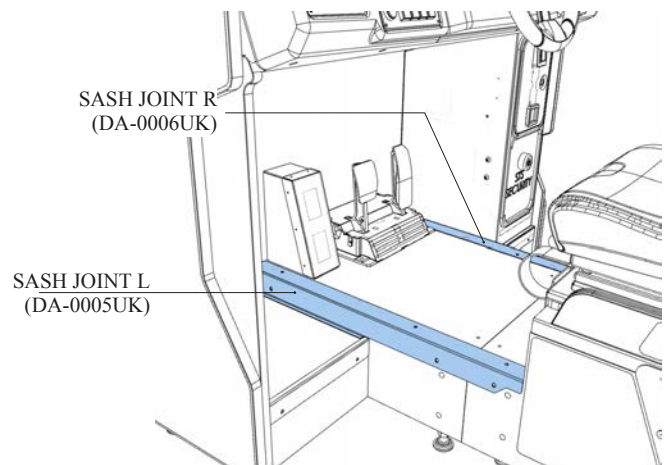

**6-3 fig. 09**

- 8** Place the SASH JOIN MID into location and secure using the remaining (4) fixings removed from Step 6.

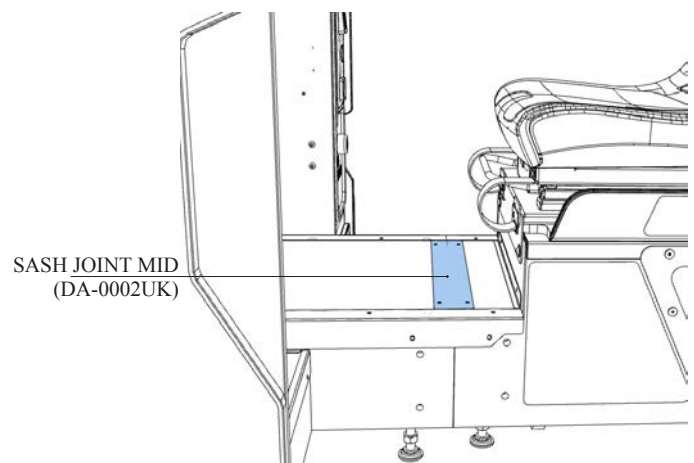

**6-3 fig. 10**

## 6-4 INSTALLING MULTIPLE CABINETS

It is important that a suitable location is secured to enable installation to be carried out safely.

*Please refer the beginning of this manual for Operational Area.*

For this exercises we will show the procedures for installing (2) cabinets. This will reflect the procedures for installing 4, 6 or 8 cabinets.

- 1 Carefully place (2) car units into position. Follow the guidelines in the OPERATIONAL AREA in the beginning of this manual.

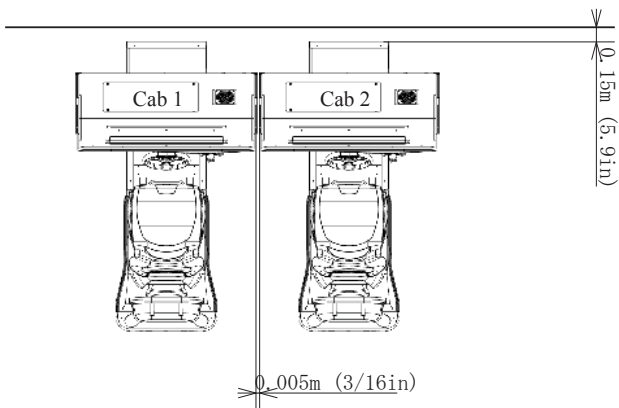

6-4 fig. 01

### STOP IMPORTANT

Each cabinet has its own dedicated mains power input. Only use the power leads supplied with this machine. When connecting 4 or more cabinets together, please refrain from using Multi-socket extension cables. **DO NOT** place more than 2 units in a single Multi-socket extension cable (Not supplied). Connecting more than 2 units in a single power extension cable may overload the circuit and cause possible electrical damage or even fire.

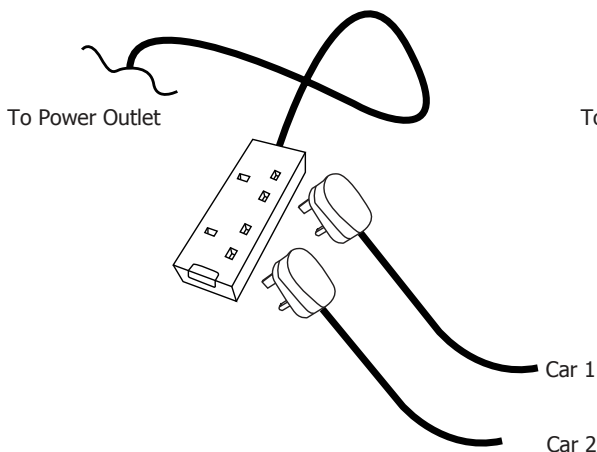

6-4 fig. 02

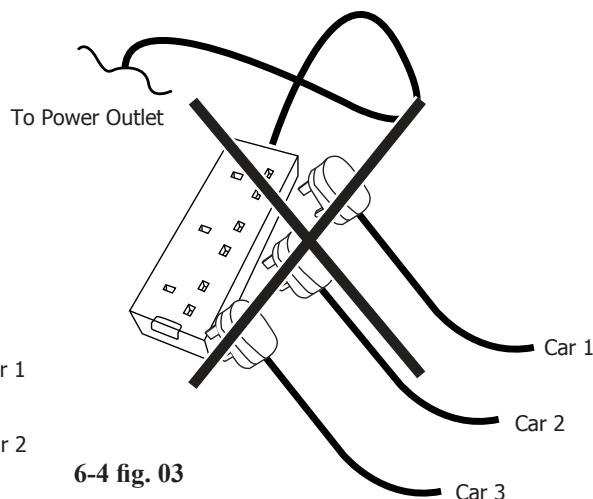

6-4 fig. 03

## 6-5 LINKING THE CABINETS (COMMUNICATION)

When installing two or more cabinets it is recommended that they be linked together via a Network cable (supplied) to encourage multiple play, whereby players race together in the same race.

### STOP IMPORTANT

**When powering the machine on for the first time, be sure NOT to have the network cables connected. Having the network cables connected when powering up for the first time will cause a network malfunction and incorrect IP addresses will be assigned.**

- 1 Make sure the ASSY BILLBOARD is fitted and all connections made. (See the beginning of this chapter).
- 2 Apply power to the cabinet and enter the TEST menu using the TEST SW located behind the panel above the display glass.
- 3 Select NETWORK SETTINGS > CABINET ID. Assign ID 1 to the first cabinet, ID 2 to the second cabinet and so on.
- 4 Select NETWORK SETTINGS > TOTAL LINKED CABINETS. Assign the number of total cabinets to be linked in the network.
- 5 Confirm changes. The Game BD and BILLBOARD will reboot. Repeat steps 1 to 5 until all cabinets within the network are assigned identification.
- 6 Using the Lan Cables (Supplied) connect each cabinet to the network port situated on the AC Bracket. The example below shows a typical set up.

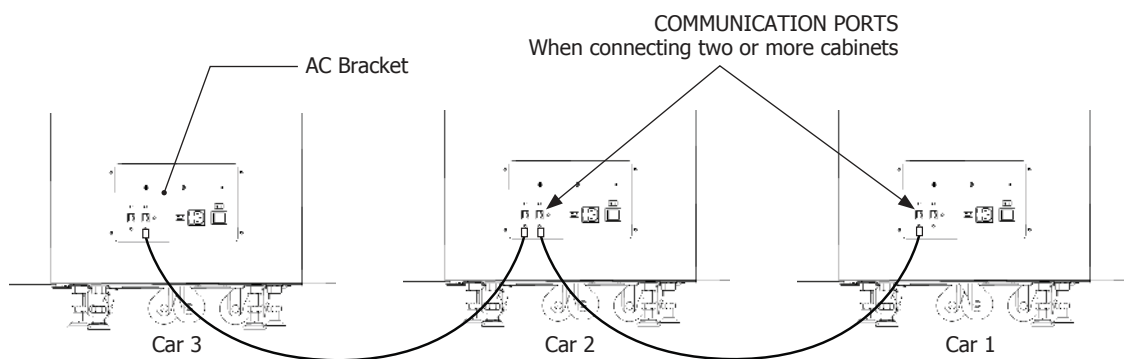

6-5 fig. 01

A maximum of 8 cabinets can be linked together.

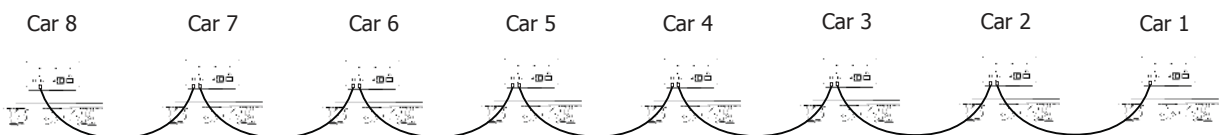

6-5 fig. 02

## 6-6 APPLYING POWER

### **STOP** IMPORTANT

Each cabinet has its own dedicated mains power input. Only use the power leads supplied with this machine. **DO NOT** connect more than 2 units in any one extension power lead. Using power leads not supplied with this product may cause an overload situation resulting in overheating, power failure or possibly fire hazard.

#### **WARNING**

- Use the power supply equipped with an earth leakage breaker. Use of power supply without such a breaker could result in fire if there is a current leakage.
- Do not expose the power cord or ground wire. If these are exposed, customers could stumble over them, for instance, and easily damage them. Additionally, if these lines are damaged, there could be a risk of electrical shock or short circuit. Set these lines at locations where they will not interfere with customer traffic, or attach covers to them.
- After laying out the power cord on the floor, be sure to always protect it. If the power cord is left exposed, it can easily be damaged, resulting in electrical shock.
- This product must only be used within the counties that it has been designed for. If the information within this section does not appear to match your electrical requirements then please contact the offices where purchased before applying power.

#### **WARNING**

- Proceed with checks and tasks as indicated in these instructions. If instructions are not followed, or if tasks and/or checks are neglected, an electric shock or other very serious accident, even fatal accident, can occur. Also, customers could be injured while operating the product.
- For safe operation, inspect and check the operation of each part of the product when turning on the power. If any defects are found, deal with them immediately. Never operate the product with defects still present.

The AC units are attached to the rear of the Assy Monitor Cabinet.

- Main switch
- Inlet for power cable connection
- Network (RJ45) for communication play.
- Fuses and fuse holder

**1** Confirm that the main switch is at OFF.

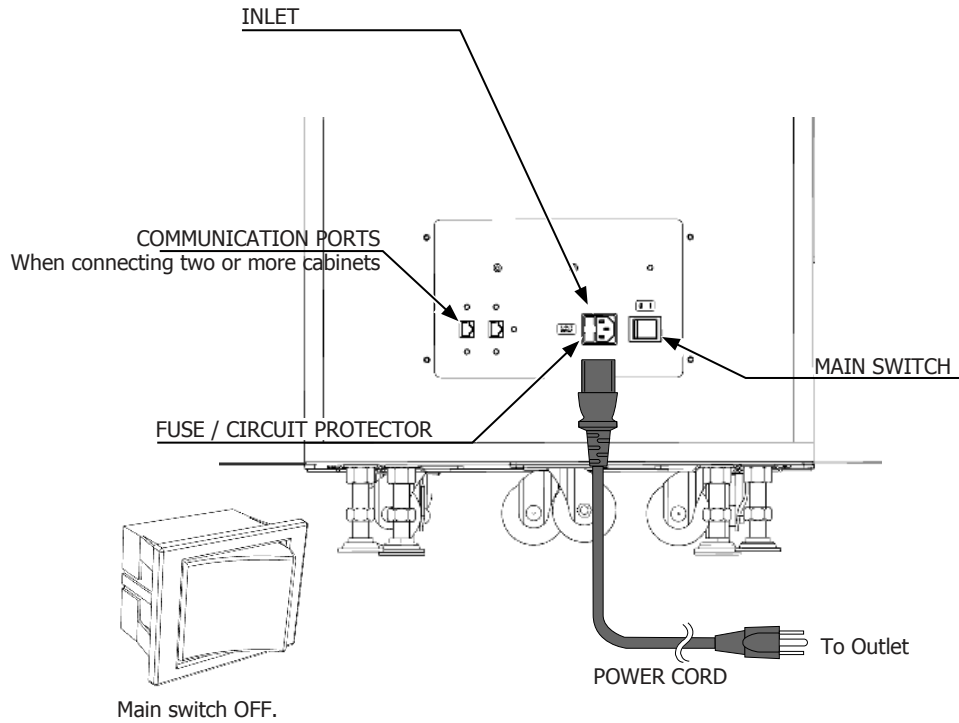

**6-6 fig. 01**

**2** Fully insert the power cord connector on the side opposite the power plug into the AC unit inlet.

**3** The power cord is laid out indoors. Protect the power cord by attaching wire cover to it. If ground will be established with a ground wire made available separately, lay out the ground wire indoors and have it protected.

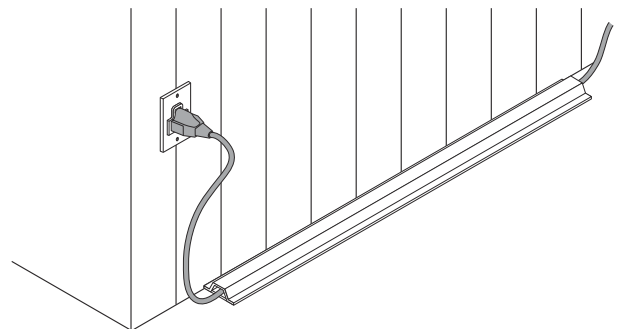

**6-6 fig. 02**

**After starting the initialization operation, wait until the advertising screen is displayed or until an error screen is displayed due to the detection of an error. If switches, etc. are inadvertently operated, faults or parts damage may occur.**

- 1** Reinspect the assembly work, paying special attention to the points below. Finally, check that there are no persons near the ride. Have all the adjusters been properly grounded, and are no casters contacting the floor surface? Have all power cables been connected correctly? Has the covers/doors been refitted to the cabinet? Have all fastening bolts and screws been tightened? Have any foreign objects been placed near the seat, or have any tools or spare screws, etc. been left on or in the product? Have any foreign objects been placed near the steering wheel?
- 2** Turn the main switch, located on the rear of the cockpit ON. This sends power throughout the product. Following the order below, output locations will activate. 1) Billboard LED lights. 2) WINDOWS/SEGA logo is displayed on LCD screen. 3) Steering Wheel calibrates - moves fully left/right then returns to the centre position. 4) Inter-cabinet communication check (in case of communication connection setting). 6) The Game loading Screen appears on screen. 7) Game attract sequence begins
- 3** If, after the initialization operation ends, the steering wheel is not at its center position (facing straight ahead), for example, reengage the power and conduct the initialization operation again. If the problem is not corrected after repeating the initialization, there is most likely a fault in the volume settings. Enter Test Mode, and check the settings. For this product, the following data and settings are still saved even if the power is turned off. Coin numbers represented in fractions (number of coins deposited that are not enough for one credit) and bonus adder count data are not saved.
- 4** Once the machine has initialised, enter the TEST screen by engaging the TEST button.
- 5** Carry out a routine check to make sure all INPUTS/OUTPUTS are functioning correctly. Please refer to section 9 of this manual for information on the I/O tests and functionality. .

## **7** PRECAUTIONS WHEN MOVING

### **WARNING**

- As used in these instructions, the term “moving” refers to moving of the product within the same building, store or facility. These instructions do not cover moving between different buildings, areas, stores or facilities, since diverse factors are involved, not only packaging but also loading onto transport vehicles, and securing the product in place during transport. To transport the product to a different building or store, contact the vendor where the product was purchased or the office indicated in these instructions. Or request that moving be done for you. This product is made up of parts that are of large size and heavy weight. Unless work is entrusted to someone with expertise in packaging and transport of such parts, a serious accident might occur.
- Even when the product is to be moved within the same building, store or facility, contact the point of purchase or the office indicated in these instructions if there will be level differences or narrow or low level entrances while moving. Or request that moving be done for you. Never disassemble the product in any way not covered in these instructions. Otherwise there could be a fire, electric shock and/or short circuit.
- Always disconnect the power cable before moving the product. If it is moved with the power cable connected, the cable could be damaged, causing fire or electric shock.
- A qualified electrician is required for moving product parts within a store and for changing indoor wiring. Do not have work performed by anyone who is not qualified. Otherwise there could be electric shock.
- Have work performed by site maintenance personnel or other qualified individuals. Do not allow people without proper knowledge and technical expertise to work on the product. Otherwise there could be an electric shock or other serious accident. Also, customers could be injured while operating the product.
- Proceed with checks and tasks as indicated in these instructions. If instructions are not followed, or if tasks and/or checks are neglected, an electric shock or other very serious accident, even fatal accident, can occur. Also, customers could be injured while operating the product.
- Be careful not to damage wiring. Before separating parts that have wiring connections, disconnect the wiring connections, unravel wire bundles and undo fastenings. Only after that, remove fasteners (screws, nuts, etc.). If wiring becomes damaged, there could be an electric shock, short circuit or fire.

## 7-1 MOVING THE MACHINE

### WARNING

- Always disconnect the power cable before moving the product. If it is moved with the power cable connected, the cable could be damaged, causing fire or electric shock.
- To move the unit over the floor, pull in the adjustors and have the casters contact the floor. While moving the unit, be careful that the casters do not roll over the power cord or the ground wire. If cord or wire is damaged, there could be electrical shocks and/or short circuits.
- When crossing a sloped or stepped area, disconnect the Display, Main Cabinet and Seat Cabinet. If you tilt them while connected together, the connection points may be damaged and personnel could be injured.
- When lifting the cabinet up steps, you must hold it by the designated handles or by the bottom surface. Lifting it by any other area may lead to damage or disfiguring to that part or surrounding parts due to the weight of the cabinet and could also lead to injury of personnel.
- When tilting the cabinet to move it across a sloped or stepped area, always use at least two people. Attempting such an operation alone can lead to accident or injury.
- Do not press the LED screen. The screen can be easily damaged and cannot be repaired if it is, meaning complete replacement will be necessary.

### CAUTION

- When moving the components do not push any of the plastic elements or shaped parts. Do not use them to pull the components along either. This may damage the parts or the surrounding parts and this could lead to accidents or injury.
- Do not use the Control Units on the Main Cabinet to push or pull the cabinet. This may damage or disfigure these parts and lead to malfunctions or injury.
- When moving the cabinet, be sure to push/pull each cabinet lengthways. Trying to move the cabinet any other way may cause the cabinet to topple over.

### CAUTION

- To work safely and precisely prepare a steady, safety stool or ladder to stand on. Climbing onto the cabinet or hanging down from it can lead to accidents.

**STOP IMPORTANT**

- If you need to move components through a narrow or low door and the only way to get the separated components through is to turn them on their side, or if a separation method other than those described in this manual is required, either make a request to the office listed in this document or the place of purchase to perform the operation or contact them regarding how to perform it. Carelessly turning the components onto their side or separating them in ways other than those depicted in this manual may lead to irreparable damage.

The machine can be moved over short distances within the same environment without the need to disassemble. However, when transporting the machine to a different location it is advised that the machine be disassembled into three individual components. These components are the (1) Display Cabinet Assembly, (2) Seat Cabinet Assembly and the (3) Assembly Billboard.

For a detailed instruction on how to disassembly the machine into these 3 parts, please refer to Chapter 6 in this manual and follow the instructions of "Installation" in reverse order.

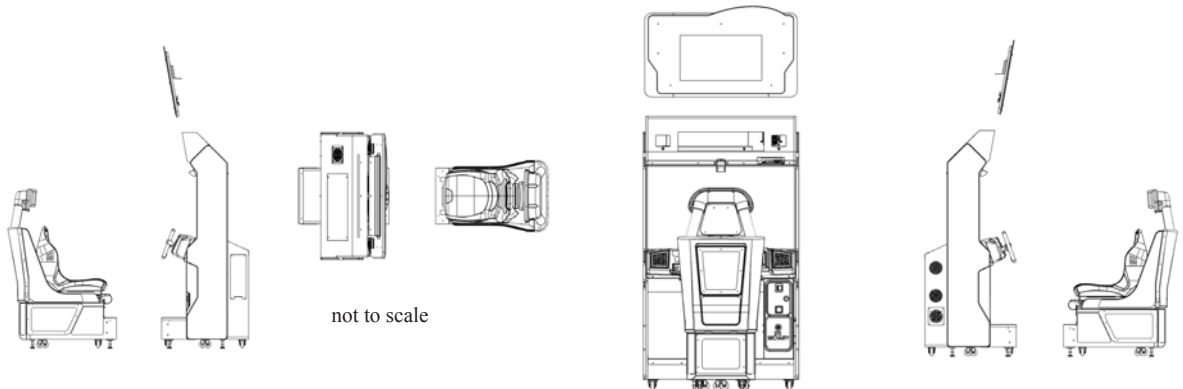

7-1 fig. 01

**STOP IMPORTANT**

- When locating the machine to a different location within the same environment, be sure to raise all leg adjusters. Failing to fully raise all leg adjusters may cause them to hit the ground and become damaged. If the leg adjusters become damaged, replace them immediately. Do not locate the machine using damaged leg adjusters. Locating the machine using damaged leg adjusters will make the product unstable.

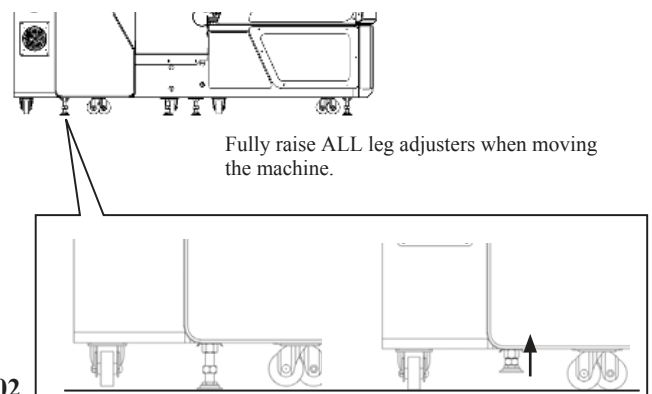

7-1 fig. 02

## 8 GAME DESCRIPTION

### DAYTONA CHAMPIONSHIP USA

Daytona Championship USA is the latest racing game from legendary arcade machine manufacturer Sega Amusements. Daytona Championship USA is a re-imagining of the classic arcade racing hit, Daytona USA. This new release contains 6 action packed tracks, 3 brand new tracks accompanied by 3 beautifully redesigned classic tracks from the original game. Players will drift, cruise and burn their way against the computer and up to 7 other real players, with the new billboard system allowing players to see their competitors' reactions in real time whilst they are burning rubber around the courses. Daytona Championship USA is the return of the titan of arcade racing. With improved handling, updated graphical designs and challenging gameplay, Daytona is back.

### MULTIPLAYER LOBBY (LINKED CABINETS)

WHEN THE MACHINE IS IN CREDIT AND THE START BUTTON IS PRESSED, THE FOLLOWING SCREEN IS DISPLAYED, INDICATING THE GAME PLAY AVAILABLE.

The first action for the player is to select whether to enter into a Multiplayer or Single Player game. When connected, the player will automatically be entered in to a Multiplayer lobby, at which point any connected cabinets can join. To enter a Single Player game by themselves, a player must hold the START button and press down on the accelerator. If the timer expires and no other players have entered the lobby, the game will automatically enter a Single Player lobby.



## Single Player Select Mode

When a cabinet is not linked up to any other cabinets or if no other players join the lobby, if the player inserts credit and presses the Start button, they will be taken straight to a Single Player game where they are given the option between QUICK RACE, CHAMPIONSHIP and TOURNAMENT (If enabled in the game settings of the test & service menu).



During this selection process, a countdown is displayed in the top right hand corner of the screen. If the player does not make a selection within this time, the highlighted option will be selected.

To make a selection, turning the steering wheel left and right will highlight the option and pressing the Accelerator pedal will confirm the player's choice.

## Single Player

### Quick Race

This game mode is available in Single and Multiplayer. It allows all 6 tracks to be played in either standard or time lap mode.



## Standard Quick Race

On the transmission screen, the player will also be able to choose whether they would like to have a standard quick race against AI players or compete in time lap mode.



Standard Quick Race is the default race type. To select time lap mode, the player must hold the start button and press down on the accelerator pedal when selecting transmission type (this is also detailed on the screen itself).



Standard Mode is against a number of A.I racers set to the difficulty of choice (difficulty is determined/adjusted by the operator in the test menu, see section 9-2). The race will finish regardless of where the player finishes in the race. If the instant rematch setting is on, the player can choose to play the same track again (if they have sufficient credits).

**Time Lap Mode**

Time Lap mode is available in Single Player only. In this mode, only the player will be racing around the track, competing to set the fastest possible lap time.



In both game modes there is a timer at the top of the screen that counts down during the race that lets the player know how long they have to get to the next check point (the amount of time is determined by difficulty set by the operator).

The player must reach the next check point for the timer to be extended to allow for finishing the race. If the player does not reach said checkpoint in the allotted time the car will stop and the race will end with the player not placing or finishing the race. However if the player adds more credits then they will be able to initiate an instant rematch option.



Upon completing the track, if the player receives a high score, they will be prompted to enter a three letter name at the name entry screen. This will then be displayed on the attract menu when the high scores for the relevant tracks are displayed.



To select a letter, the player turns the steering wheel left and right to highlight a letter and selects their choice by pressing down on the accelerator pedal. During this time, a countdown timer will appear in the top right hand corner. If no name is selected before the timer reaches zero or if the start button is pressed, the game will generate a three letter name for the player automatically.



### Championship

This game mode is available in Single Player only. It challenges the player to three races, one beginner track, one advanced track and one expert track. The goal of this game mode is to place in the top three positions to advance to the next race. If the player fails, they can insert a credit to retry the current race they are on.



Upon completing the third track, if the player receives a high score they will be prompted to enter their name at the name entry screen. This will then be displayed on the attract menu.



## Tournament

Tournament is a specific mode that allows the operator to create a timelimited event that will run between 1 to 30 days. During the selected time period, players compete for the fastest times on tracks that can be determined by the operator in the test menu.



When enabled Tournament provides its own High Score Table with time and dates stamps for scores. These scores remain on display after the event has expired until the mode is turned off in the test menu.

(see section XX for more details on how to alter Tournament mode).

## Track Select

If a player selects Quick Race in Single Player, the track select screen will then display.

To select the track the player would like to play, the steering wheel must be turned left or right and the accelerator pedal pressed down to confirm (as shown in the bottom right hand corner of the screen). The player can choose from six tracks:



- Daytona International Speedway (Beginner)
- Three-seven Speedway (Beginner)
- Lakeside Castle (Advanced)
- Dinosaur Canyon (Advanced)
- Metro City (Expert)
- Seaside Street Galaxy (Expert)

The difficulty of each track is labelled on the select screen. During this time, a countdown timer will appear in the top right hand corner. If no track is selected before the timer reaches zero, the track that is currently highlighted by the player will be selected automatically.

## Transmission/Car Select

After selecting a track, the player will be prompted to select either automatic or manual transmission.



Automatic is recommended for new players. In this transmission, the player will not be required to change gears as it will be done for them.



Manual transmission is recommended for more experienced players. This will require the player to change the gears themselves. There are different stats for each transmission as shown on the right hand side of the screen.

During this time, a countdown timer will appear in the top right hand corner. If no car transmission is selected before the timer reaches zero, the car transmission that is currently selected by the player will be chosen automatically.



From here, the player will enter the track preview screen, after which the race will begin.

## Multiplayer

The first action for the player is to select whether to enter into a Multiplayer or Single Player game. When connected, the player will automatically be entered in to a Multiplayer lobby, at which point any connected cabinets can join.

If players wish, they can enter a single player quick race from the multiplayer lobby by holding the start button and accelerator together to drop out of the current Multiplayer lobby and in to their own game.

### Multiplayer Track Select

After all players have entered the lobby, the track select screen will be shown allowing multiple players to vote on what track they wish to race on. The track with the most amount of votes will be selected.

During this time, a countdown timer will appear in the top right hand corner. If no track is selected before the timer reaches zero, the track that is currently highlighted by the player will be chosen automatically.



If the votes are tied the track that is the easiest difficulty will be selected automatically.

### Multiplayer Transmission Select

After selecting a track, the player will be prompted to select either automatic or manual transmission.

Automatic is recommended for new players. In this transmission, the player will not be required to change gears as it will be done for them.



Manual transmission is recommended for more experienced players. This will require the player to change the gears themselves. There are different stats for each transmission as shown on the right hand side.

During this time, a countdown timer will appear in the top right hand corner. If no car transmission is selected before the timer reaches zero, the car transmission that is currently selected by the player will be chosen automatically.

## Real Racers Only

This option is only available in multiplayer. This determines whether the AI will be in the race with the players (this is the default option.) To initiate Real Racers Only, the players must hold the start button while selecting car transmission. Whether the real racers are on or off is determined by the players voting. The majority option will then be chosen.

## HUD (Heads up Display)

This is everything on screen that feeds important in-game information back to the player.



The image above represents the standard HUD screen in a single player race. It displays:

- Lap Number – Indicates the current lap the player is on and how many laps the race is in total
- Lap Time Counter – Indicates the current lap time as well as any previous lap times
- Timer – Indicates how much time the player has to reach the next checkpoint. If the timer reaches zero, the race will end
- Race Position – Indicates the current ranking of the player in the race (e.g. 10<sup>th</sup> out of 20 racers)
- Mini-map – This displays a section of the map surrounding the player. The player car is shown as a blue arrow, with other players/AI racers as red arrows. Checkpoint markers are denoted with a black line
- Speedometer – Indicates the speed the player is currently travelling at. If in manual transmission, this displays the number of the current gear the player is in. The speedometer also has a colour scale of blue, yellow and red. Blue indicates accelerating (low revs), yellow indicates the need to change gear (the best time to change gear) and red means the player will stop accelerating as they have reached the maximum revs in that gear
- Race Banner – This indicates what car is in what position in the race. This is displayed in a scrolling style from right to left

## Single Player Time Lap HUD

The Time Lap mode HUD contains all the elements of the standard HUD with some other included features:



- **Course Record Time** – This displays the current record time for a single lap
- **Total Record Time** – This displays the player's current best time for the entire track
- **Your Time** – This displays the player's current lap time
- **Lap Number** – Indicates the current lap the player is on and how many laps the race is in total
- **Lap Time Counter** – Indicates the current lap time as well as any previous lap times
- **Timer** – Indicates how much time the player has to reach the next checkpoint. If the timer reaches zero, the race will end
- **Mini-map** – This displays a section of the map surrounding the player. The player car is shown as a blue arrow. Checkpoint markers are denoted with a black line
- **Speedometer** – Indicates the speed the player is currently travelling at. If in manual transmission, this displays the number of the current gear the player is in. The speedometer also has a colour scale of blue, yellow and red. Blue indicates accelerating (low revs), yellow indicates the need to change gear (the best time to change gear) and red means the player will stop accelerating as they have reached the maximum revs in that gear

## Player Views

While driving in the game, players can select from one of four views. These views can be selected by pressing the corresponding view buttons 1, 2, 3 and 4 respectively on the cabinet. The views are labelled and shown below:

View 1



View 2



View 3



View 4



## **9** EXPLANATION OF TEST AND DATA DISPLAY

Perform tests and data checks periodically by manipulating the TEST Button and SERVICE Button in the cabinet. Follow the instructions in this chapter to conduct checks when the game machine is first installed, when money is being collected, or when the game machine does not operate properly.

Shown overleaf are the tests and screens to be used for different problems.

### **WARNING**

When installing 2 or more cabinets which are networked together. The **GAME SETTINGS** which are adjusted within the first cabinet are reflected throughout all cabinets within that network.

### **IMPORTANT**

When changing the game configuration within the **TEST MODE**, be sure to exit all screens in the correct manner by choosing exit. **DO NOT** turn the machine **ON/OFF** to resume game. Changes **WILL NOT** take effect unless the correct method is used.

## 9-1 SWITCH UNIT

### **⚠ WARNING**

Never touch places other than those specified. Touching places not specified can cause electric shock and short circuit accidents.

### **STOP IMPORTANT**

Adjust the sound to the optimum volume, taking into consideration the environmental requirements of the installation location.

Removing the Coin Meter circuitry renders the game inoperable

### SWITCH UNIT

Open the service panel and the switch unit shown will appear.  
The functioning of each SW is as follows:

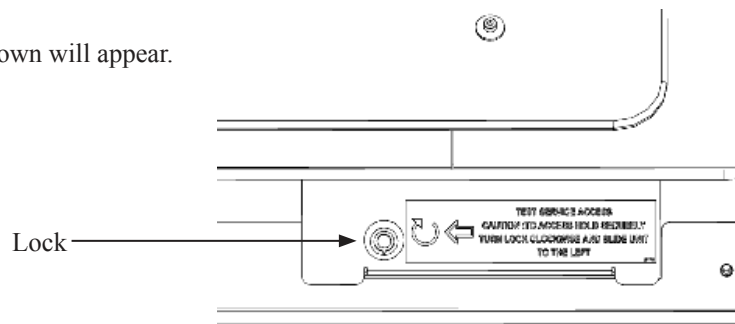

9-1 fig.01

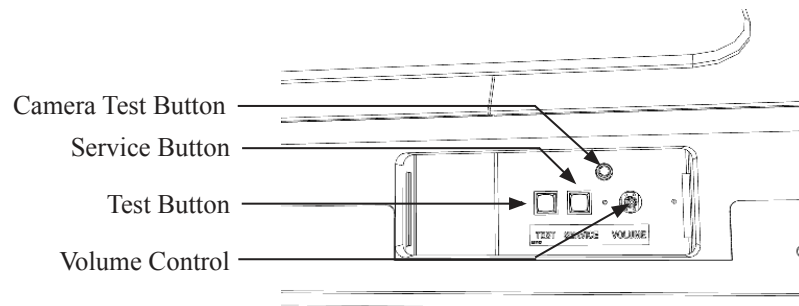

9-1 fig. 02

TEST Button (TEST):	For the handling of the Test Button, refer to the following pages.
SERVICE Button (SERVICE):	Gives credits without registering on the coin meter.
Sound Volume Switch (SOUND VOLUME):	Adjust sound volume for all of the machines' speakers.

## 9-2 TEST MODE

### STOP IMPORTANT

- The details of changes to Test Mode settings are saved when you exit from Test Mode by selecting EXIT from the system test mode menu. Be careful because if the power is turned off before that point, changes to the settings will be lost.
- Entering the Test Mode clears fractional number of coins less than one credit and bonus adder data.
- Use with the specified settings. If settings other than those specified are used, inappropriate operations or malfunction may occur.

### Test & Service Menu

The test menu is the area where you can perform a variety of tests and change numerous settings to best suit the customers' needs and those of your business. It also stores and contains data that will allow you to see when it is most popular, set up tournaments and check and troubleshoot any errors.. The TEST button and the SERVICE buttons control navigation of the menu system.

The following options are available from the Test Menu:

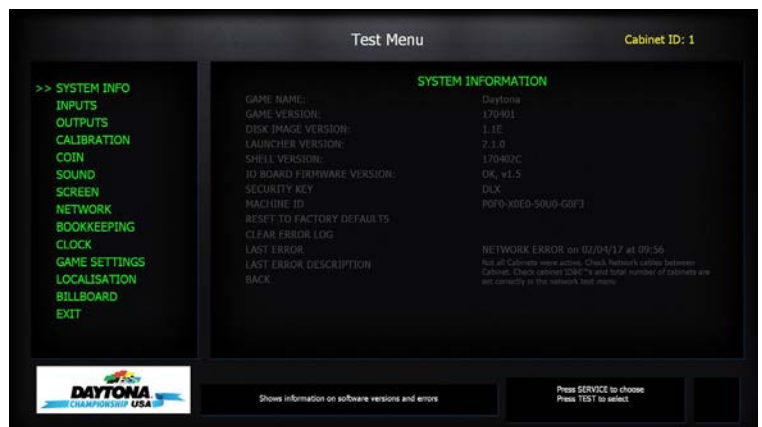

9-2 fig.01

The user will use the SERVICE button to select the desired test and the TEST button to activate the test in the left hand pane of the display.

**SYSTEM INFORMATION:**

General Information on installed software and hardware

**INPUTS:**

Test routine for input peripherals

**OUTPUTS:**

Test routine for output peripherals

**CALIBRATION:**

Calibration routines for input peripherals

**COIN:**

Test routine for coin handling

**SOUND:**

Test routine for audio outputs

**SCREEN:**

Test routine for display screen

**NETWORK:**

Test routine for Ethernet link

**BOOKKEEPING:**

System meters and bookkeeping

**CLOCK:**

System clock setting

**GAME SETTINGS:**

Test routine for Game Specific settings

**LOCALISATION:**

Routine to change in game languages

**BILLBOARD:**

Test routine for Video Billboard (If fitted)

**EXIT:**

Leave System Menu and launch game

## STOP IMPORTANT

- When changing the game configuration within the TEST MODE, be sure to exit all screens in the correct manner by choosing exit. DO NOT turn the machine ON/OFF to resume game. Changes WILL NOT take effect unless the correct method is used.

### System Information

Select 'System Information' from the Test Menu to display the System Information menu. This test displays general system information regarding the hardware configuration and installed software.

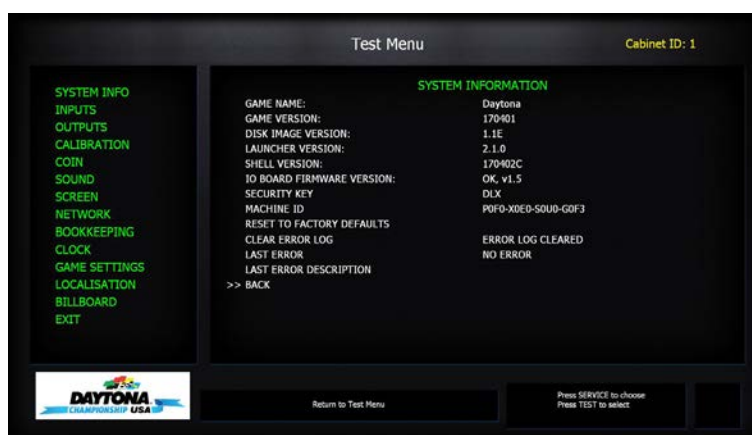

9-2 fig.02

<b>GAME NAME:</b>	Name of the installed game.
<b>GAME VERSION:</b>	Version number of installed game.
<b>DISK IMAGE VERSION:</b>	Version number for master disk image.
<b>LAUNCHER VERSION:</b>	Version number for System Launcher.
<b>SHELL VERSION:</b>	Version number for Shell.
<b>IO BOARD F/W VERSION:</b>	Displays <b>I/O Board Firmware Revision</b> if valid IO Board is fitted, otherwise displays <b>FAILED</b> .
<b>SECURITY KEY:</b>	Displays <b>Security Key Data</b> or if not present <b>NOT FITTED</b> .
<b>MACHINE ID:</b>	Displays <b>unique machine ID</b> or <b>UNKNOWN SECURITY KEY</b> .
<b>RESET TO FACTORY DEFAULTS:</b>	If Test is pressed when this item is highlighted then all settings are returned to factory defaults and the cabinet will restart (Requires confirmation).
<b>CLEAR ERROR LOG:</b>	Clears all recorded errors.
<b>LAST ERROR:</b>	Displays <b>Last recorded error with Time &amp; Date stamp</b> or <b>NO ERRORS</b> . Pressing Test whilst over this item scrolls through the last 10 errors.
<b>LAST ERROR:</b>	Displays <b>Verbose description of current error and troubleshooting advice</b> .
<b>BACK:</b>	Exit this test and return to Test & Service Menu.

## Inputs

Select 'Input Test' from the Test Menu to display the Input Test menu. This test is used to test system inputs such as steering wheels, pedals and switches.

This menu is used to test the System Inputs such as Steering, Pedals and Buttons. To implement the test, press each device that is listed and check the results on screen.

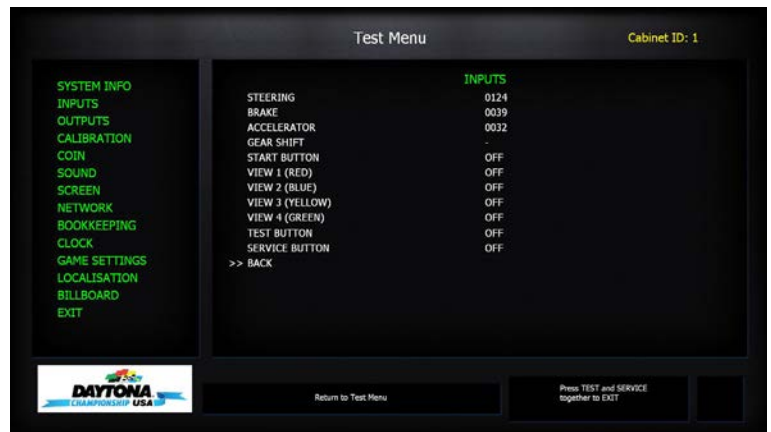

9-2 fig. 03

<b>STEERING:</b>	0-255 Maximum range
<b>BRAKE:</b>	0-255 Maximum range
<b>ACCELERATOR:</b>	0-255 Maximum range
<b>GEAR SHIFT:</b>	- (not in use), UP, DOWN, 1,2,3,4
<b>START BUTTON:</b>	ON = pressed, OFF = not pressed
<b>VIEW 1:</b>	ON = pressed, OFF = not pressed
<b>VIEW 2:</b>	ON = pressed, OFF = not pressed
<b>VIEW 3:</b>	ON = pressed, OFF = not pressed
<b>VIEW 4:</b>	ON = pressed, OFF = not pressed
<b>TEST:</b>	ON = pressed, OFF = not pressed
<b>SERVICE BUTTON:</b>	ON = pressed, OFF = not pressed
<b>EXIT:</b>	Press TEST and Service simultaneously to exit

To exit this menu you must press the TEST and SERVICE buttons simultaneously.

## Outputs

Select 'OUTPUT TEST' from the Game Test menu to display the Output Test Menu. This test is used to test system outputs such as lamps or actuators.

Press the SERVICE button to move the cursor to the desired test item.

Press the TEST button to test the selected item.

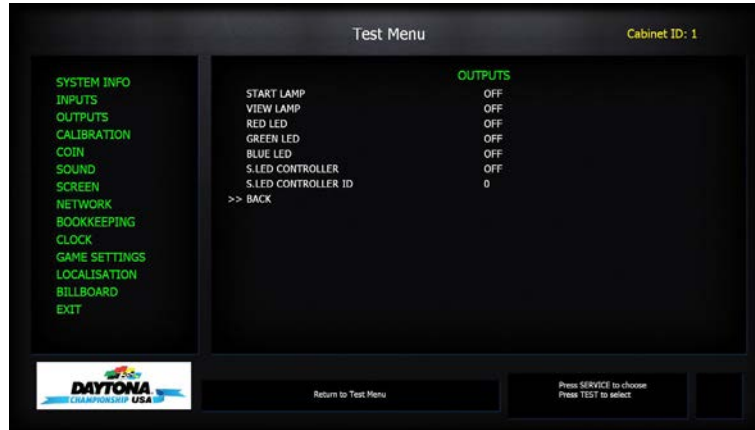

9-2 fig.04

<b>START LAMP:</b>	ON = Lamp ON, OFF = Lamp OFF
<b>VIEW LAMP:</b>	ON = Lamp ON, OFF = Lamp OFF
<b>RED LED:</b>	ON = Lamp ON, OFF = Lamp OFF
<b>GREEN LED:</b>	ON = Lamp ON, OFF = Lamp OFF
<b>S.LED CONTROLLER:</b>	OFF= OFF, ATTRACT, IN GAME, RACE LEADER, CRASH, OVERTAKE= Test lighting animation
<b>S.LED CONTROLLER ID:</b>	<b>Test Lighting routine specific to cabinet ID</b>
<b>BACK:</b>	Exit this test and return to Test & Service Menu

Please note that turning on more than one LED will change the colour accordingly:

RED and GREEN:	Panel will be YELLOW
RED and BLUE:	Panel will be MAGENTA
GREEN and BLUE:	Panel will be CYAN
RED, GREEN and BLUE:	Panel will be WHITE

The user will use the SERVICE button to select the desired output and the TEST button to change the output status.

EXIT This will exit the menu and turn all lamps and LED's off.

Move the cursor to EXIT and press the TEST button to return to the TEST MENU screen.

## Calibration

Select 'Calibration Test' from the Test Menu screen to display the Calibration Test menu.

This test is used to calibrate analogue inputs and to test and set steering force feedback. Use the SERVICE button to move the cursor to the desired test item. Press the TEST button to enter the selected item.

This test is used to test system outputs such as lamps or actuators.

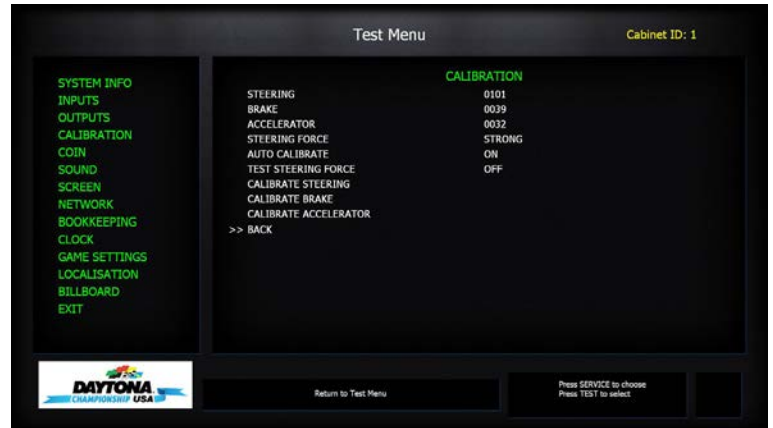

9-2 fig. 05

- STEERING:** This displays the current Calibration setting for the steering wheel.  
**Current input value (0-255)**
- BRAKE:** This displays the current Calibration setting for the Brake Pedal.  
**Current input value (0-255)**
- ACCELERATOR:** This displays the current Calibration setting for the Accelerator Pedal.  
**Current input value (0-255)**
- STEERING FORCE:** This sets the amount of force feedback used in the steering wheel when playing the game. There are four options available:
- OFF** – No steering force will be used
  - WEAK** – Minimal steering force will be used
  - NORMAL** – Normal steering force will be used
  - STRONG** – Maximum steering force will be used.
- AUTO CALIBRATE** ON/OFF Enables or disables automated calibration of steering at start up.
- CALIBRATE STEERING\*** Launches Calibration routine
- CALIBRATE BRAKE\*** Launches Calibration routine
- CALIBRATE ACCELERATOR\*** Launches Calibration routine
- CALIBRATE STEERING ROUTINE\***  
Starts the steering calibration routine. The wheel will automatically be calibrated by turning full left and then full right. No input is needed from the user once the test has been started. If Auto Calibration has been disabled please follow the on-screen instructions to manually calibrate
- CALIBRATE BRAKE ROUTINE\***  
Starts the brake calibration routine. The user must follow the on screen prompts to fully depress and then release the brake pedal for 5 seconds.
- CALIBRATE ACCELERATOR ROUTINE\***  
Starts the accelerator calibration routine. The user must follow the on screen prompts to fully depress and then release the accelerator pedal for 5 seconds.
- BACK** Exit this test and return to Test & Service Menu

The user will use the SERVICE button to select the desired item and the TEST button to change the value. Move the cursor to EXIT and press TEST button to return to the Test menu.

## Coin Settings

This part of the test menu is used to set credit related parameters. Select COIN from the Test menu to display the Coin Settings Menu.

Use the SERVICE button to move the cursor to the desired test item.  
Press the TEST button to enter the selected item.



9-2 fig.06

This text displays the accumulative coins and credits values. Freeplay can be turned on/off by cycling through the Credit Settings options.

<b>COIN COUNT:</b>	Coin count value from IO board (cannot be reset)
<b>CREDITS:</b>	Total number of credits added to system
<b>SERVICE CREDITS:</b>	Total number of Service credits added to system
<b>ENTRY TYPE:</b>	Payment Method (COIN*\CARD\ SWIPE)
<b>COIN SETTING:</b>	The following coin settings are available:

1 COIN 1 CREDIT*	1 COIN 2 CREDITS
1 COIN 3 CREDITS	1 COIN 4 CREDITS
1 COIN 5 CREDITS	1 COIN 6 CREDITS
2 COINS 1 CREDIT	1 COIN 1 CREDIT
2 COINS 3 CREDITS	3 COINS 1 CREDIT
4 COINS 1 CREDIT	1 COIN 1 CREDIT
2 COINS 2 CREDITS	3 COINS 3 CREDITS
4 COINS 5 CREDITS	5 COINS 1 CREDIT
3 COINS 1 CREDIT	5 COINS 2 CREDITS
2 COINS 1 CREDIT	4 COINS 2 CREDITS
5 COINS 3 CREDITS	1 COIN 1 CREDIT
2 COINS 2 CREDITS	3 COINS 3 CREDITS
4 COINS 4 CREDITS	5 COINS 6 CREDITS
FREEPLAY	

<b>BACK:</b>	Exit this test and return to Test & Service Menu. This will save any changes to freeplay on this cabinet only.
--------------	--

Use the TEST button on the EXIT option to return to the System Menu.

## Sound Settings

This test is used to set audio levels for the game and to test function of the speaker system. Select ‘Sound Settings’ from the test menu to display the Sound Settings Menu.

Use the SERVICE button to move the cursor to the desired test item.  
Press the TEST button to enter the selected item.

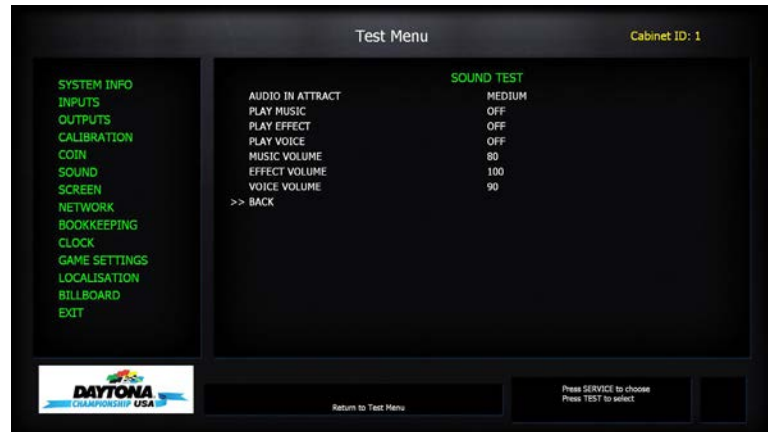

9-2 fig. 07

<b>AUDIO IN ATTRACT:</b>	Volume in attract mode (OFF/LOW/MEDIUM*/HIGH)
<b>PLAY MUSIC:</b>	Play a sample of game music
<b>PLAY EFFECT:</b>	Play a sample of game sound effects
<b>PLAY VOICE:</b>	Play a sample of game voice
<b>MUSIC VOLUME:</b>	Game Music level 00 to 100 (Default 80)
<b>EFFECT VOLUME:</b>	Game Sound Effect level 00 to 100 (Default 100 )
<b>VOICE VOLUME:</b>	Game Voice level 00 to 100 (Default 90 )
<b>TEST MUSIC:</b>	Plays looping music audio
<b>TEST EFFECT:</b>	Plays test sound effect audio
<b>TEST VOICE:</b>	Plays test vocal audio
<b>TEST FRONT SPEAKERS:</b>	Plays music audio with emphasis on front speakers
<b>TEST REAR SPEAKERS:</b>	Plays music audio with emphasis on rear speakers
<b>BACK:</b>	Exit this test and return to Test & Service Menu

The user will use the SERVICE button to select the desired test and the TEST button to activate the test. Move the cursor to BACK and press the TEST button to return to the Test Menu screen.

## Screen

This test is used to test the game display is working correctly.

Use the SERVICE button to move the cursor to the desired test item.  
Press the TEST button to enter the selected item.

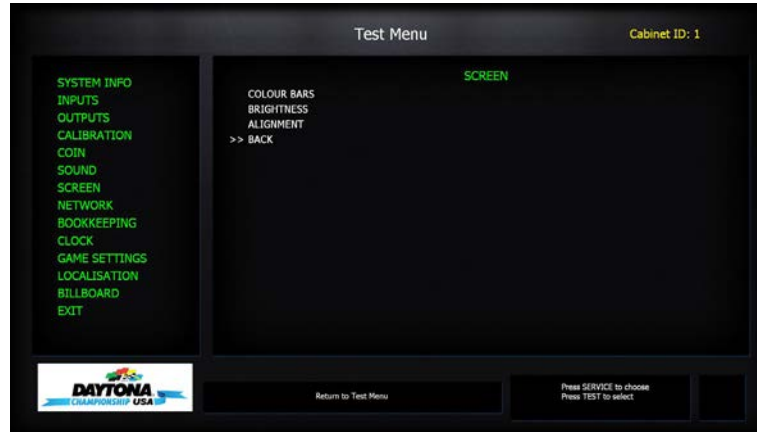

9-2 fig. 08

### Colour Bars:

Selecting this will display the following screen.

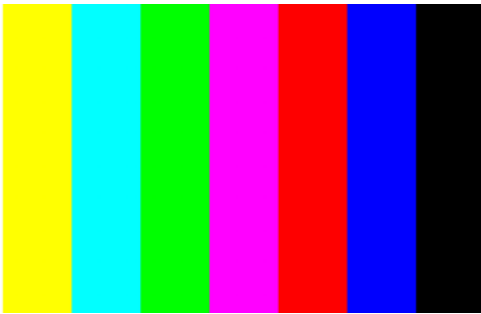

9-2 fig. 09

### Brightness:

Selecting this will display the following screen.

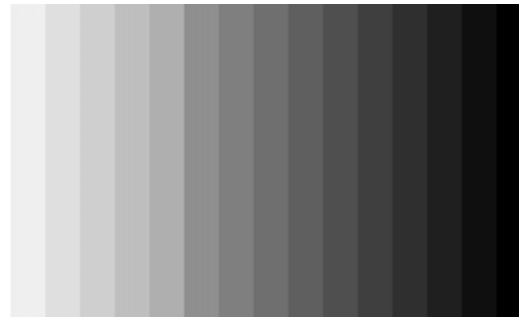

9-2 fig. 10

### Grid Alignment:

Selecting this will display the following screen.

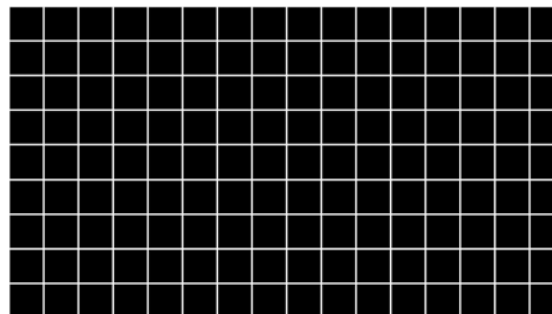

9-2 fig. 11

## Network Test

This test is used to test the network link between cabinets (if connected). Select 'NETWORK' from the Test menu to display the Network Test Menu.

### IMPORTANT NOTES:

In any cabinet configuration on cabinet must be set to ID=1, this is the Server that will control the network operation. When making changes to "cabinet ID" the cabinet should not be networked to any other cabinets. Once Changes are made "CONFIRM CHANGES" must be selected to commit the change and restart the cabinet.

Use the SERVICE button to move the cursor to the desired test item.  
Press the TEST button to enter the selected item.

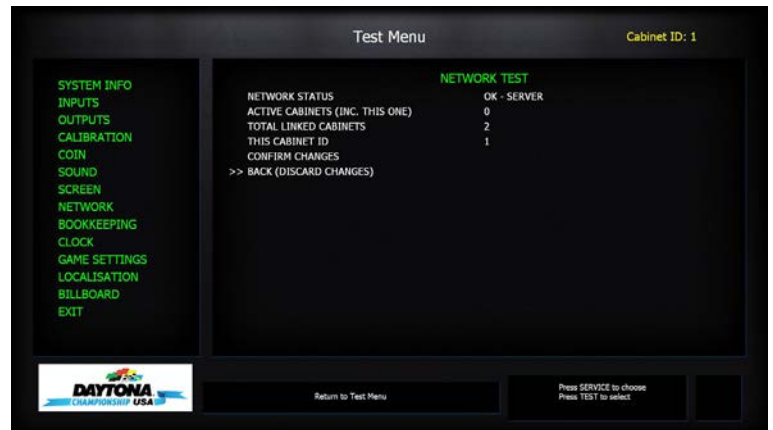

9-2 fig . 12

**NETWORK STATUS:**

OK – SERVER=Connected as server OK CLIENT = Connected as client

**ACTIVE CABINETS**

**(INC THIS ONE):**

The total number of cabinets connected or UNKNOWN

**TOTAL LINKED CABINETS:**

The total number of cabinets networked together. Must be set identically on all connected cabinets. If this value is changed, the user must use CONFIRM CHANGES and the cabinet will restart.

**CABINET ID:**

ID of cabinet from 1 to 8. If this value is changed, the user must use CONFIRM CHANGES and the cabinet will restart.

**CONFIRM CHANGES:**

The user will be prompted to press TEST again to confirm. If the user presses TEST again, the action is confirmed and the PC will reset. If the user presses SERVICE the action is aborted and settings discarded.

**BACK**

Exit this test and return to Test & Service Menu

Move the cursor to BACK and press the TEST button to return to the Test Menu screen.

## Bookkeeping – Screen 1

This test is used to review statistical data from the system. It consists of 7 screens of data. Screen 1 contains an overview of game play data. Select 'BOOKKEEPING' from the Test menu to display the Bookkeeping Test Menu.

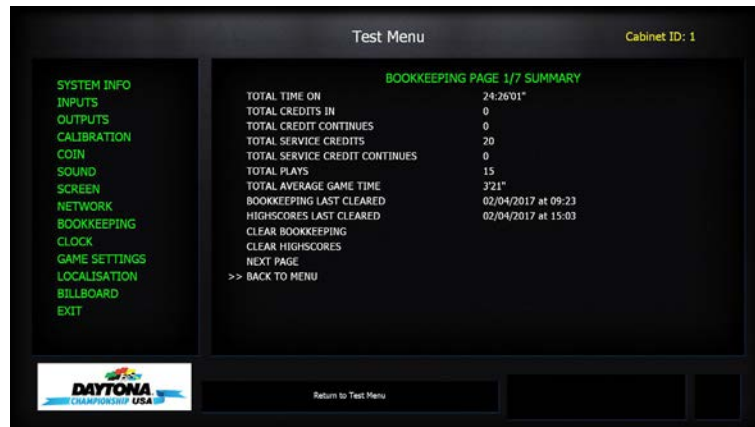

9-2 fig. 13

<b>TOTAL TIME ON:</b>	The total time the cabinet has been switched on, in HH:MM:SS
<b>TOTAL CREDITS IN:</b>	The total number of credits entered
<b>TOTAL CREDIT CONTINUES:</b>	The total number of credits used for continue games
<b>TOTAL SERVICE CREDITS:</b>	The total number of service credits entered
<b>TOTAL SERVICE CONTINUES:</b>	The total number of service credits used for continue games
<b>TOTAL PLAYS:</b>	The total number of games played
<b>TOTAL AVERAGE GAME TIME:</b>	The average game time for all games
<b>BOOKKEEPING LAST CLEARED:</b>	The time the bookkeeping meters were last cleared
<b>HIGH SCORES LAST CLEARED:</b>	The time the High Score tables were last cleared
<b>CLEAR HISCORES:</b>	When selected, the user will be prompted to confirm. If the user confirms (with the TEST button), the hi-score table is reset. If the user presses SERVICE, then no action is taken.
<b>CLEAR BOOKKEEPING:</b>	When selected (with the TEST button), the user will be prompted to confirm. If the user confirms, the bookkeeping meters are reset to zero. If the user presses SERVICE, then no action is taken.
<b>NEXT PAGE:</b>	Proceed to bookkeeping screen #2
<b>EXIT:</b>	Exit to System Menu

Move the cursor to NEXT PAGE and press the TEST button to proceed to bookkeeping screen #2.

Move the cursor to EXIT and press the TEST button to return to the Test Menu.

## Bookkeeping – Screen 2

This page displays accumulative individual modes and total plays. This is a cumulative total; from the last point in time that the Bookkeeping was cleared.

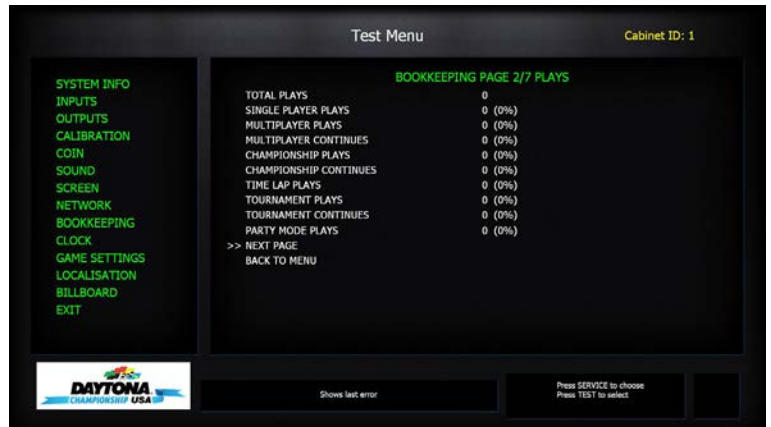

9-2 fig. 14

<b>TOTAL PLAYS:</b>	The total number of games played
<b>SINGLE PLAYER PLAYS:</b>	The total number of single player games
<b>MULTIPLAYER PLAYS:</b>	The total number of multiplayer games
<b>CHAMPIONSHIP PLAYS:</b>	The total number of Championship games
<b>TOURNAMENT PLAYS:</b>	The total number of Tournament games
<b>PARTY MODE PLAYS :</b>	The total number of party mode games*
<b>NEXT PAGE:</b>	Proceed to bookkeeping screen #3
<b>BACK TO MENU:</b>	Return to Test & Service Menu

Move the cursor to NEXT PAGE and press the TEST button to proceed to bookkeeping screen #3.  
Move the cursor to EXIT and press the TEST button to return to the Test Menu.

\*Feature to be made available via future software update to Deluxe Cabinet

## Bookkeeping – Screen 3

This page displays total game time and average game times for single and multiplayer modes. This is a cumulative total from the last point in time that Bookkeeping was cleared. All times are displayed in the format: **HHHH:MM:SS**



9-2 fig. 15

<b>TOTAL AVERAGE GAME TIME:</b>	Total average game time, all modes combined.
<b>AVERAGE GAME TIME - SINGLE PLAYER:</b>	Average game time for all single player modes.
<b>AVERAGE GAME TIME - MULTIPLAYER:</b>	Average game time for all multiplayer modes.
<b>AVERAGE GAME TIME - CHAMPIONSHIP:</b>	Average game time for Championship mode.
<b>NEXT PAGE:</b>	Proceed to bookkeeping screen #4
<b>BACK TO MENU:</b>	Return to Test & Service Menu

Move the cursor to **NEXT PAGE** and press the **TEST** button to proceed to bookkeeping screen #4.  
Move the cursor to **EXIT** and press the **TEST** button to return to the Test Menu.

## Bookkeeping – Screen 4

This page displays a breakdown of the games on individual days. This is a cumulative total from the last point in time that the bookkeeping was cleared.

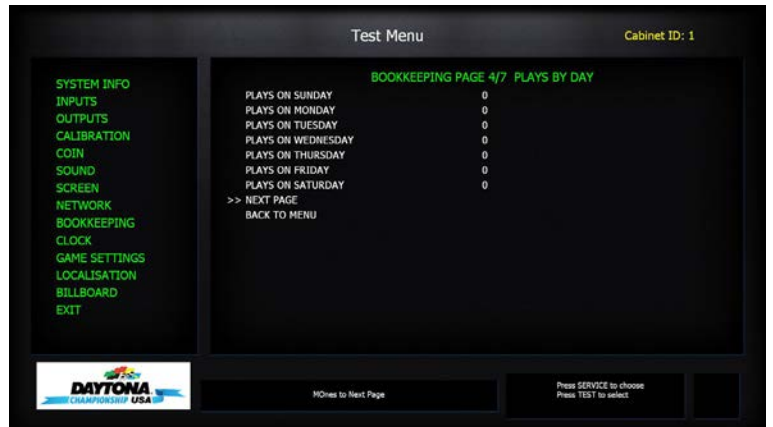

9-2 fig. 16

<b>PLAYS ON SUNDAY:</b>	Cumulative count of plays for this day
<b>PLAYS ON MONDAY:</b>	Cumulative count of plays for this day
<b>PLAYS ON TUESDAY:</b>	Cumulative count of plays for this day
<b>PLAYS ON WEDNESDAY:</b>	Cumulative count of plays for this day
<b>PLAYS ON THURSDAY:</b>	Cumulative count of plays for this day
<b>PLAYS ON FRIDAY:</b>	Cumulative count of plays for this day
<b>PLAYS ON SATURDAY:</b>	Cumulative count of plays for this day
<b>NEXT PAGE:</b>	Proceed to bookkeeping screen #5
<b>BACK TO MENU:</b>	Return to Test & Service Menu

Move the cursor to NEXT PAGE and press the TEST button to proceed to bookkeeping screen #5.  
 Move the cursor to EXIT and press the TEST button to return to the Test Menu.

## Bookkeeping – Screen 5

This page displays a breakdown of the games into individual hours. This is a cumulative total from the last point in time that the bookkeeping was cleared.

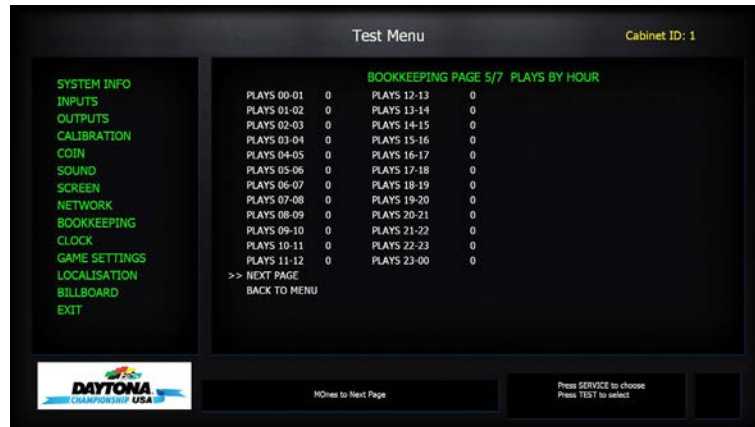

9-2 fig. 17

- PLAYS XX-XX:** Cumulative count of plays during the specified hour
- NEXT PAGE:** Proceed to bookkeeping screen #6
- BACK TO MENU:** Return to Test & Service Menu

Each hour is logged separately in 24 hour format therefore:

logs games played between 12am and 1am

logs games played between 1am and 2am...and so on. 23-24 logs games played between 11pm and 12am.

Move the cursor to NEXT PAGE and press the TEST button to proceed to bookkeeping screen #6.

Move the cursor to EXIT and press the TEST button to return to the Test Menu.

## Bookkeeping – Screen 6

This page displays a breakdown of the races into individual race tracks. This is a cumulative total from the last point in time that the bookkeeping was cleared.

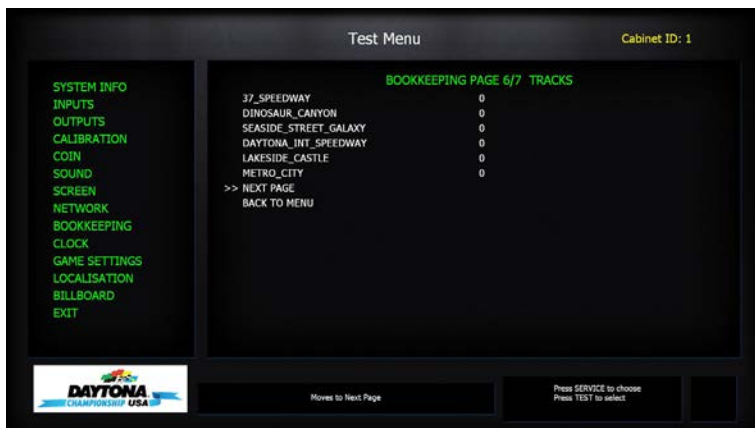

9-2 fig. 18

- TRACK #1 -6:** Cumulative count of plays on the specified track
- NEXT PAGE:** Proceed to bookkeeping screen #7
- BACK TO MENU:** Return to Test & Service Menu

Move the cursor to NEXT PAGE and press the TEST button to proceed to bookkeeping screen #7.  
 Move the cursor to EXIT and press the TEST button to return to the Test Menu.

## Bookkeeping – Screen 7

This page displays a breakdown of the different cars used in all game modes. This is a cumulative total from the last point in time that the bookkeeping was cleared.

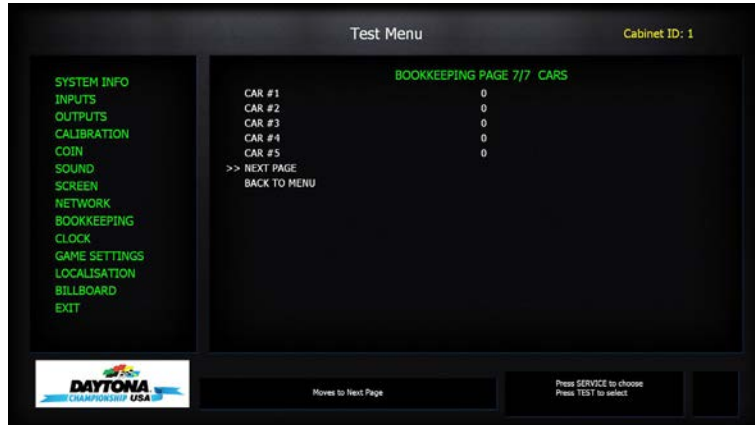

0-2 fig. 19

**CAR #1 -5:** Cumulative count of plays using the specified car  
**NEXT PAGE:** Proceed to bookkeeping screen #1  
**BACK TO MENU:** Return to Test & Service Menu

Use the SERVICE button to navigate and the TEST button to action changes to the following options. Move the cursor to BACK TO MENU and press the TEST button to return to the Test Menu.

### CAR REFERENCE TABLE

<b>CAR 1</b>	 9-2 fig. 20
<b>CAR 2</b>	 9-2 fig. 21
<b>CAR 3</b>	 9-2 fig. 22
<b>CAR 4</b>	 9-2 fig. 23
<b>CAR 5</b>	 9-2 fig 24

## Clock Setting

This test is used to set the current time and date of the computer system. Select 'CLOCK' from the Test Menu to enter the Clock Setting screen. When selected, the screen will show fields for YEAR, MONTH, DATE, HOURS, MINUTES and SECONDS. The SERVICE button is used to select the desired option and the TEST button will increment the value of that option between specified parameters.



9-2 fig 25

<b>CURRENT TIME:</b>	Shows the current time, displayed in 24 hour clock format.
<b>CURRNT DATE:</b>	Shows the Current Date, displayed in the following format DD/MM/YYYY
<b>YEAR:</b>	Variable from 2016 to 2070
<b>MONTH:</b>	Variable from 01 to 12
<b>DATE:</b>	Variable from 1 to 28, 29, 30 or 31 (dependant on MONTH & YEAR)
<b>HOURS:</b>	Variable from 0 to 23
<b>MINUTES:</b>	Variable from 0 to 59
<b>SECONDS:</b>	Variable from 0 to 59
<b>BACK:</b>	Return to Test & Service Menu after adjusting clock to new value.

Use the SERVICE button to navigate and the TEST button to action changes to the following options. Move the cursor to BACK and press the TEST button to return to the Test Menu.

## Game Settings 1

This allows game parameters to be viewed and changed. Select GAME SETTINGS from the Test Menu screen to enter the Game Settings screen.

If more than one cabinet is linked then game settings must be made from Cabinet 1 (player 1) Test & Service Menu

### CABINET 2-8 IN LINKED GAME

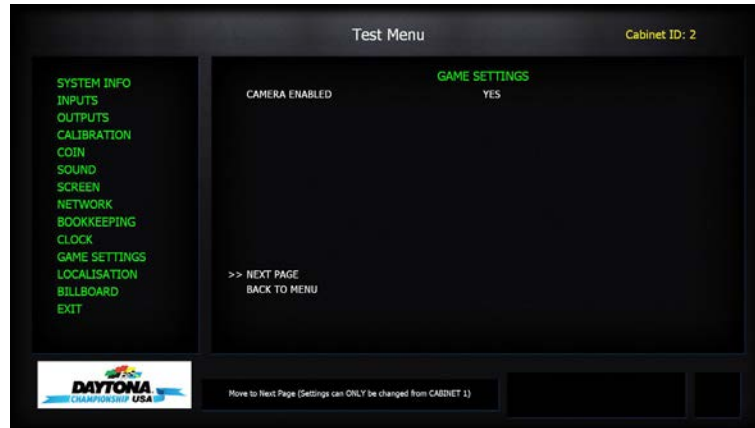

9-2 fig 26

Limited options can be changed when a linked cabinet that is not ID=1

<b>CAMERA ENABLED:</b>	Use the player camera in game (YES*/NO)
<b>NEXT PAGE:</b>	Proceed to Game Settings screen #1
<b>BACK TO MENU:</b>	Return to Test & Service Menu

## **WARNING**

- When installing 2 or more cabinets which are networked together. The GAME SETTINGS which are adjusted within the first cabinet are reflected throughout all cabinets within that network.

## Single Player/Cabinet 1 in Linked Game

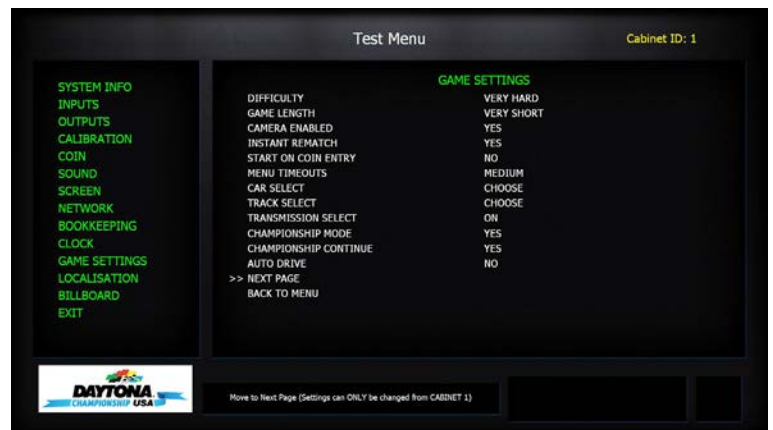

9-2 fig 27

<b>DIFFICULTY:</b>	Set the game difficulty (V EASY/EASY/MEDIUM*/HARD/V HARD)
<b>GAME LENGTH:</b>	Set the game length (V SHORT/SHORT/MEDIUM*/LONG/V LONG)
<b>CAMERA ENABLED:</b>	Use the player camera in game (YES*/NO)
<b>INSTANT REMATCH:</b>	Offer instant rematch after multiplayer game (ON*/OFF)
<b>START ON COIN ENTRY:</b>	Game starts as soon as credit is available (YES/NO*)
<b>MENU TIMINGS:</b>	Length of time given to make menu selections (SHORT/MEDIUM*/LONG)
<b>CAR SELECT:</b>	Is player offered a choice of Cars (CHOOSE/RANDOM/FIXED)
<b>TRACK SELECT :</b>	Is player offered a choice of tracks (CHOOSE/RANDOM/FIXED)
<b>TRANSMISSION SELECT:</b>	Is player offered a choice of transmission (ON*/AUTO ONLY/MANUAL ONLY)
<b>CHAMPIONSHIP MODE:</b>	Is Championship Mode Enabled (YES*/NO)
<b>CHAMPIONSHIP CONTINUE:</b>	Is Championship Continue offered (YES*/NO)
<b>AUTO DRIVE:</b>	Is Auto drive feature enabled (YES/NO*) This will accelerate automatically if the player does not use the pedal
<b>NEXT PAGE:</b>	Proceed to Game Settings (Advanced)
<b>BACK TO MENU:</b>	Return to Test & Service Menu

\* Denotes default values

Use the SERVICE button to navigate and the TEST button to action changes to the following options. Move the cursor to BACK and press the TEST button to return to the Test Menu. Alternatively highlight NEXT PAGE and push the TEST button to go to the advanced game settings page.

## Game Settings (Advanced)

This page allows for advanced game parameters to be viewed and changed. Select GAME SETTINGS from the Test Menu screen to enter the Game Settings screen. From there highlight NEXT PAGE and push the TEST button to reach the GAME SETTINGS (ADVANCED) screen.

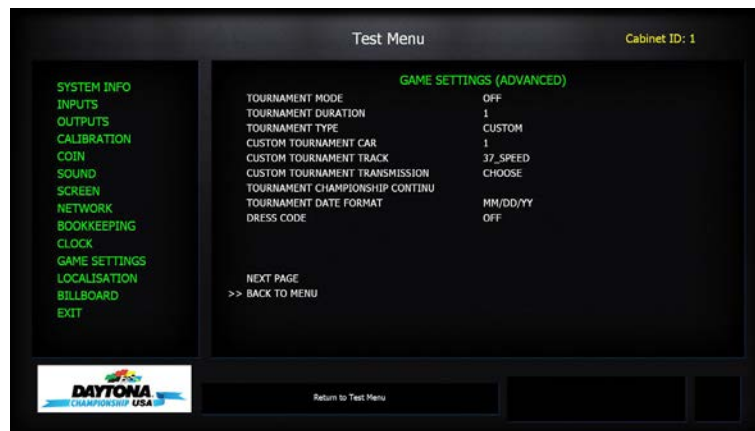

9-2 fig 28

<b>TOURNAMENT MODE:</b>	Enables or Disables Tournament Mode (YES/NO*)
<b>TOURNAMENT DURATION:</b>	Sets the duration of tournament in days (*1-30 days)
<b>TOURNAMENT TYPE:</b>	Define tournament type (CHAMPIONSHIP/CUSTOM*)
<b>CUSTOM TOURNAMENT CAR:</b>	Defines Car for tournament if custom is enabled (1,2,3,4,5, *Choice)
<b>CUSTOM TOURNAMENT TRACK:</b>	Defines Track for tournament if custom is enabled (1,2,3,4,5,6, *Choice)
<b>CUSTOM TOURNAMENT TRANS:</b>	Defines Transmission for tournament if custom is enabled (MANUAL/AUTO/ *Choice)
<b>LANGUAGE:</b>	Sets game text language (English*/French/Italian/Spanish/Chinese/Russian/Turkish/Portuguese)
<b>NEXT PAGE:</b>	Proceed to Game Settings screen #1
<b>BACK TO MENU:</b>	Return to Test & Service Menu

## Tournament Set Up

Tournament allows an operator to set up a time limited single player event. This can be customised and records are stored in a unique "Tournament" high score table. Once the time has elapsed the high score table will still be displayed but no further record can be set.

To set up a tournament, please make the desired adjustments in the Game settings (advanced) screen as described on the previous page.

Before attempting to change the duration of days for tournament mode, please follow these instructions:

- Turn tournament mode off via "game settings" in the test menu
- Start the game up (let it load to the attract screen)
- Return to the test menu
- Turn the tournament mode back on
- Change duration to whichever amount of days you wish to test

Otherwise the cabinet will not give you the option of tournament mode in the menu.

Use the SERVICE button to navigate and the TEST button to action changes to the following options. Move the cursor to BACK and press the TEST button to return to the Test Menu.

### Localisation

This allows the game language to be selected. On linked cabinets this can only be carried out from Cabinet ID 1. (Player 1).

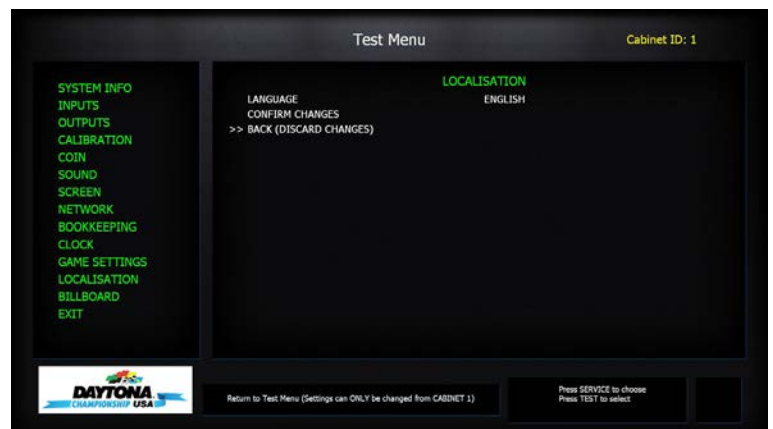

9-2 fig 29

#### LANGUAGE:

Select the game language

ENGLISH/FRENCH/ITALIAN/SPANISH/PORTUGUESE/RUSSIAN/TURKISH

#### CONFIRM CHANGES:

The user will be prompted to press TEST again to confirm. If the user presses TEST again, the action is confirmed and the PC will reset. If performed on Cabinet 1 of a group of linked cabinets all will be changed and restarted

If SERVICE is pressed the action is aborted and settings discarded.

#### BACK TO MENU:

Return to Test & Service Menu

## 10 VIDEO DISPLAY

### CAUTION

The LCD display screen is adjusted prior to leaving the factory. Avoid any unnecessary adjustment.

### IMPORTANT

- If the adjustment method in this manual does not resolve the problem contact the customer service number in this manual or your supplier.
- Do not stick tape, stickers or anything else onto the screen. Any kind of adhesive may damage the surface of the screen.

## 10-1 GENERAL DESCRIPTION

This specification applies to the 46.0 inch Color TFT-LCD Module P460HVN02.0. This LCD module has a TFT active matrix type liquid crystal panel 1,920x1,080 pixels, and diagonal size of 46.0 inch. This module supports 1,920x1080 resolution display. Each pixel is divided into Red, Green and Blue sub-pixels or dots which are arranged in vertical stripes. Gray scale or the brightness of the sub-pixel color is determined with a 10-bit gray scale signal for each dot.

The P460HVN02.0 has been designed to apply the 10-bit 2 channel LVDS interface method. The main feature of P460HVN02.0 would be high brightness, high contrast, wide viewing angle, high color saturation, symmetry narrow bezel, edge LED backlight and high color depth.

### \* General Information

Items	Specification	Unit	Note
Active Screen Size	46.0	Inch	
Display Area	1018.08(H) x 572.67(V)	mm	
Outline Dimension	1044.08(H) x 598.67(V) x 9.9(D)	mm	1
Driver Element	a-Si TFT active matrix		
Display Colors	10 bit (8bit+FRC), 1073.7M	Colors	
Number of Pixels	1,920x1080	Pixel	
Pixel Pitch	0.53025 (H) x 0.53025(W)	mm	
Pixel Arrangement	RGB vertical stripe		
Display Operation Mode	Normally Black		
Display Orientation	Landscape/Portrait Enable		
Surface Treatment	AG	Haze = 11%	

Note:

(1) Dmax: 26.5mm (Front bezel to Driver cover); Dmin: 9.9mm (Front bezel to Bezel back)

## 10-2 CLEANING THE SCREEN

### ⚠ CAUTION

- Since the LCD display screen is susceptible to damage, pay careful attention to its handling. When cleaning, refrain from using water or volatile chemicals.
- Do not climb onto the control panel. This could lead to injuries, such as bumping your head.
- When reaching across the control panel to clean the screen there is a risk of hurting your shoulder or arm. Use a mop with a non-feathery, soft, dry cloth mop head and wipe the surface of the screen.

When the screen surface becomes dirty with dust, etc., clean it by using a soft cloth such as gauze. When water, and volatile chemicals such as benzene, thinner, etc., spill on the screen surface, it may be subject to damage, therefore, do not use them.

Also, since the surfaces are susceptible to damage, refrain from rubbing them with a hard material or using a duster. If the screen is especially dirty, call in a professional cleaner.

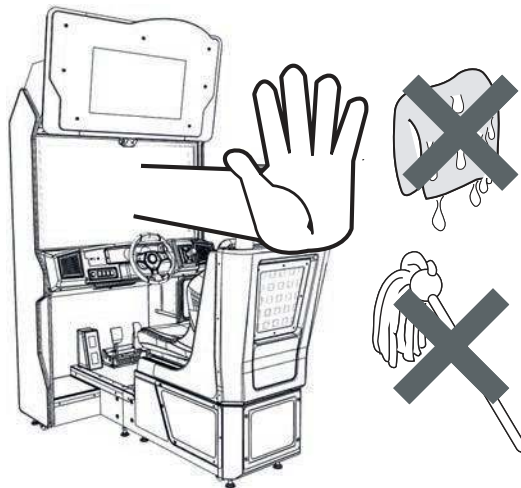

10-2 fig. 01

## 10-3 ADJUSTMENT METHOD

All adjustment values are set accurately at the time of shipping from the factory. Do not readjust these values needlessly or apply adjustments not specified in this manual. The display may not appear properly if the values are incorrect.

### CONTROL - ADJUSTMENT PROCEDURE

This sections explains basic control procedures for making adjustments using the buttons on the 'Monitor Adjustment Board'

### LOCATION

The DISPLAY CONTROL BD is located on the rear of the Display Panel. Remove the Back Door to gain access.

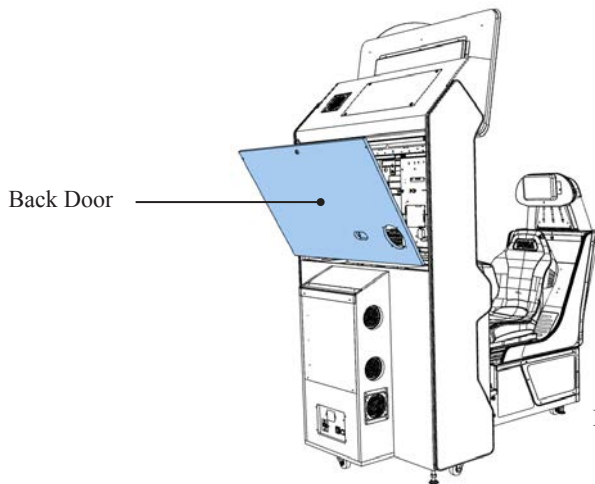

10-3 fig. 01

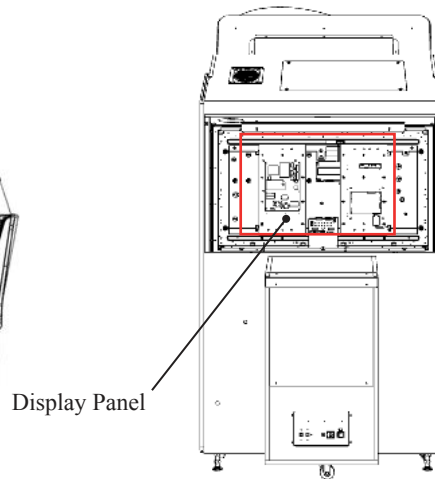

10-3 fig. 02

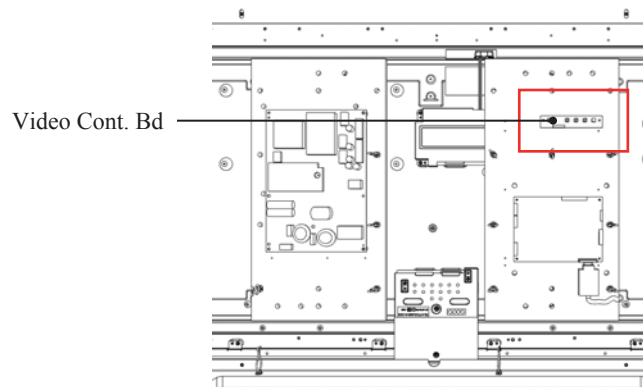

10-3 fig. 03

## Button Names and Functions

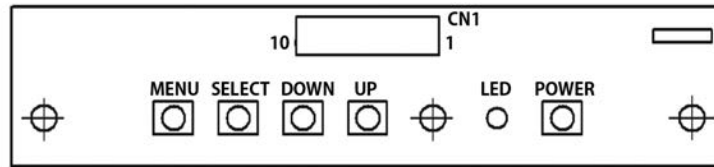

10-3 Fig. 04

**MENU:** Turn the Picture Menu display ON and OFF.

**SELECT:** Gains entry to the Item selected in the menu. (Highlights in Yellow when selected)  
Exits the Item adjustment. Any changes made during this operation are actioned.

**DOWN:** Moves the cursor (Black Bar) down to select a menu item.  
Decrease the value of, or change, a selected menu item.

**UP:** Move the cursor (Black Bar) up to select a menu item.  
Increase the value of, or change, a selected menu item.

**LED:** LED illuminates green: Monitor is operating.  
LED flashes red: Power is off.

**POWER:** Turns the LCD Display ON and OFF. (Usually, it's not necessary to operate.)

## On-Screen Display (OSD)

Press the MENU Button while the OSD is not displayed to bring up the Picture Menu.  
On the Picture Menu, it is possible to perform various screen adjustments.

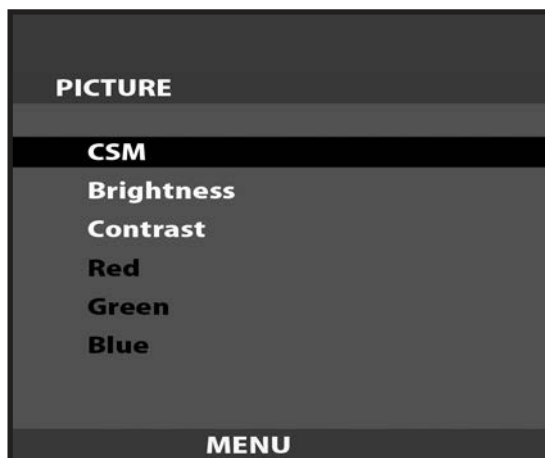

10-3 Fig. 05

Use the UP and DOWN Buttons to move the 'Black Bar' to the item you want to adjust.  
After selecting the desired item, pressing the SELECT Button will extend the MENU Screen and allow adjustments to be changed.

Within each item, press the SELECT Button to exit the adjustment screen. The adjustment values at this time will be saved simultaneously.

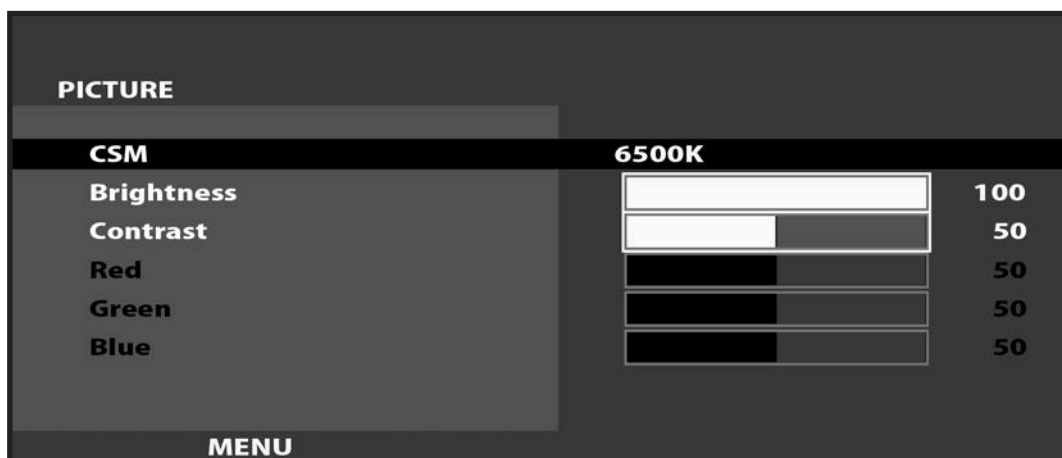

10-3 Fig. 06

The current options are set at :

CSM	-	6500K
Brightness	-	100
Contrast	-	50

## On-Screen Display (OSD) <continued>

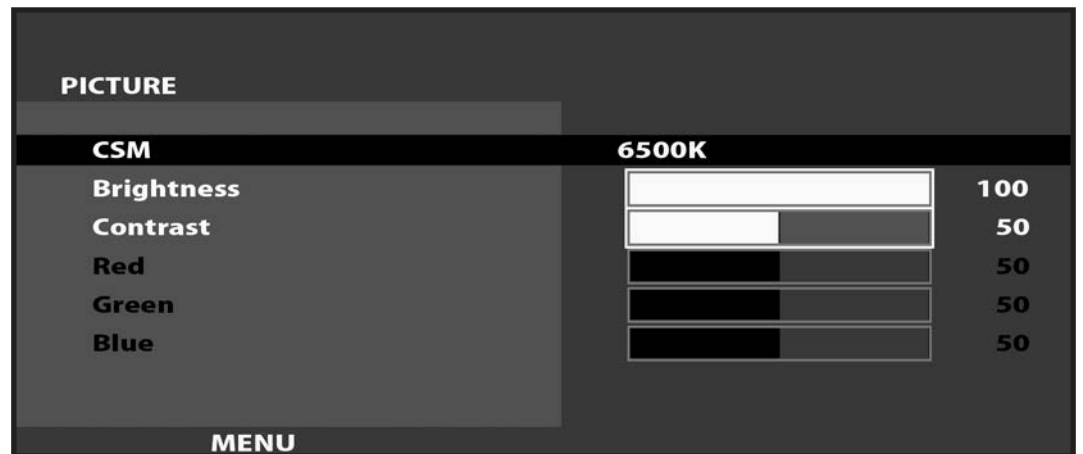

10-3 Fig. 07

### Available Settings

CSM (Selects Operation Mode)  
Selection available - 6500K - 9300K - USER

BRIGHTNESS (Adjust Brightness)  
Adjust screen Brightness. - Values: 0 - 100  
(0" being the darkest setting, and "100" being the brightest)

CONTRAST (Adjust Contrast)  
Adjust Contrast level. - Values: 0 - 100  
(0" having the least amount of difference between light and dark, and "100" having the most)

NOTE : The Red, Green, and Blue adjustments are unavailable in the Mode of Operation selected on the Screen shown in 11-3 Fig. 06. These adjustments can only be made is the CSM option is set to 'User'.

## 11 CONTROL UNITS

### WARNING

- When working with the product, be sure to turn the power off. Working with the power on may cause an electric shock or short circuit.
- Be careful not to damage the wires. Damaged wires may cause an electric shock, short circuit or present a risk of fire.
- Do not touch any parts that are not specified in these directions. Touching unspecified locations may lead to electric shock or cause short circuits.
- This work should be performed by site maintenance personnel or other skilled professionals. Work performed by non-technical personnel can cause a severe accident such as an electric shock.
- Exercise due caution in performing soldering procedures. If soldering iron is handled carelessly, there could be fires or burns.
- Proceed very carefully when heating thermal contraction tube. Careless operations can result in fires or burns.

### CAUTION

- When fastening plastic parts, be careful not to tighten screws and nuts excessively. Otherwise parts may be damaged, resulting in injuries from fragments, etc.
- Be careful not to get hand or finger caught when removing or attaching the parts.
- Disconnection and connection of connectors will be performed within the narrow cabinet space. Take due care not to scratch or otherwise injure yourself.
- Take care when carrying the removed Control Units. Such heavy lifting carries a risk of injury to back or shoulders.

### IMPORTANT

- After the Potentiometer has been replaced, be sure to set the values on the test mode calibration screen and the input test screen and check variations in the volume value.
- Handle parts inside the Control Unit very carefully. Be especially careful to avoid damage, deformation or loss of these parts. If any one of these parts is lost or defective, it can result in damages and/or faulty operations.

**⚠ CAUTION**

- After the unit has been disassembled and reassembled again, check carefully that the unit has been reassembled correctly.
- Be sure to inspect the outer covers on both gear and brake units.
- Assemble so that there is no gap between the L and R covers. If there is a gap or rattling, the players could get fingers or hands caught, resulting in injury.

**STOP IMPORTANT**

- Once the product has been disassembled, use slack preventive agent. Coat screws with suitable amounts of this agent and then tighten them. If this agent is not used, the product might start rattling or come apart.
- Use the slack preventive agent prescribed in these instructions. If any other agent is used, there could be chemical changes that inhibit the use of screws and part surfaces could be damaged.
- Be careful not to damage or lose small parts or screws.
- When a part has been replaced, be sure to always make adjustments and check conditions in Test Mode.

# 11-1 CONTROLLER - EXPLODED DIAGRAM

The exploded diagram below shows the Active Steering Wheel Assy. Each part is tagged with a part number. Please quote this number when ordering spare parts.

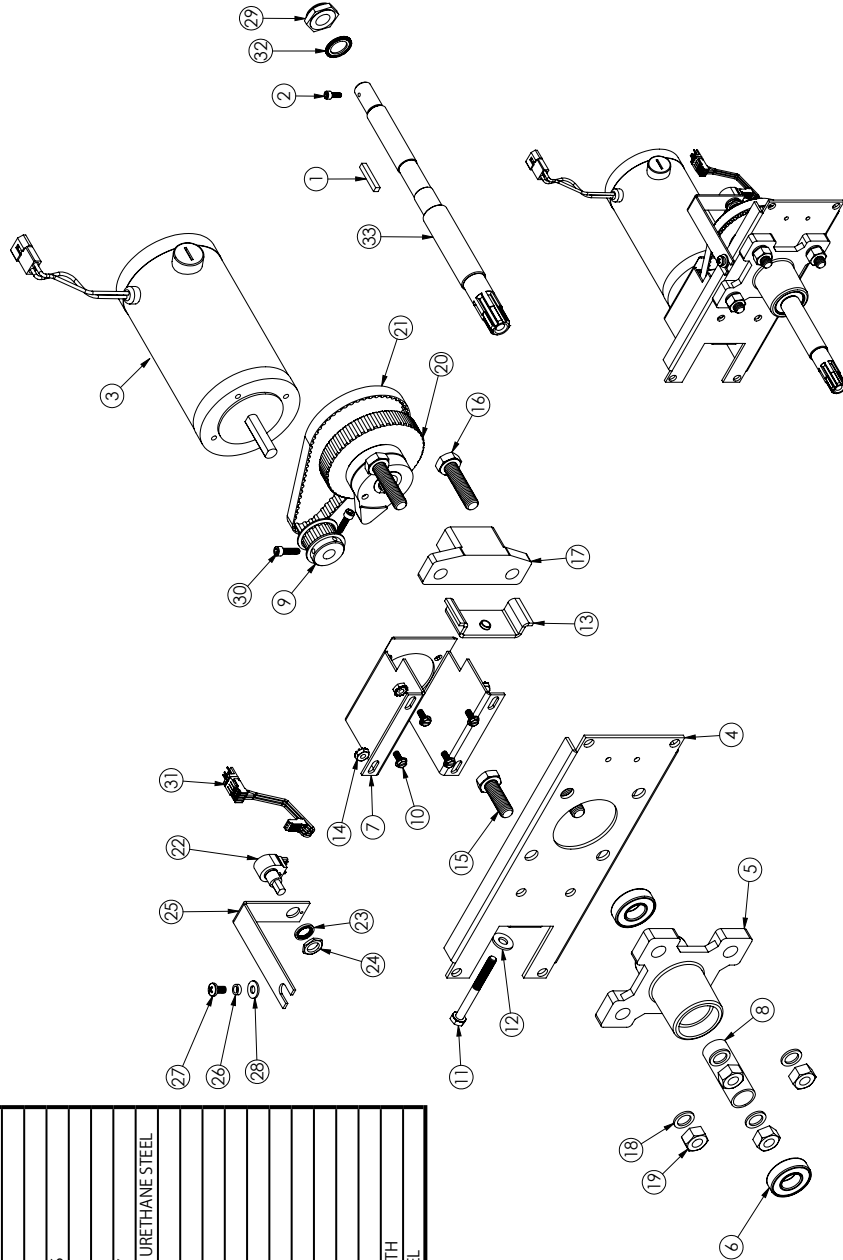

ITEM No	QTY	PART No	DESCRIPTION
1	1	DA-0101	KEY SHAFT 4MM X 4MM X 25MM
2	1	DA-0102	SCREW #6-32 X 3/8" SHCS
3	1	DA-0103	MOTOR & CONNECTOR ASSY
4	1	DA-0104	WHEEL MTG BKT
5	1	DA-0105	BEARING HOUSING
6	2	DA-0106	BEARING .9843ID X 1.259OD X 1.575W
7	1	DA-0107	MOTOR MTG BKT
8	1	DA-0108	BEARING SPACER
9	1	DA-0109	PULLEY 16T ALUMINIUM
10	4	DA-0110	SCREW #8-32 X 3/8" HEX WSHRHD
11	1	DA-0111	SCREW M6 X 60MM HHCS
12	1	DA-0112	5/16 FLAT WSHR .06T ZINC PLT
13	1	DA-0113	BKT BELT TENSION
14	4	DA-0114	NUT 10-32 HEX SEMS ZINC PLT
15	2	DA-0115	SCREW M10 X 30MM HHCS
16	2	DA-0116	SCREW M10 X 40MM HHCS
17	1	DA-0117	DIE CAST WHEEL STOP W/BUMPERS
18	4	DA-0118	LOCKWASHER M10 RIBBED
19	4	DA-0119	NUT HEX M10
20	1	DA-0120	STOPPER PIE CAM & PLASTIC PULLEY
21	1	DA-0121	TIMING BELT FOR STEERING WHEEL URETHANE STEEL
22	1	DA-0122	SK POT NEI SENSORCUBE
23	1	DA-0123	LOCKWASHER INT 3/8" X 9/16"
24	1	DA-0124	NUT HEX 3/8" - 24 X 3/32 THK
25	1	DA-0125	POT MTG BKT
26	1	DA-0126	SPACER POT MTG BKT
27	1	DA-0127	SCREW #10-32 X 3/8" PHPNHD
28	1	DA-0128	#10 FLAT WASHER
29	1	DA-0129	NUT HEX NYLOCK 1/2-20
30	2	DA-0130	SCREW #8-32 X 5/8" SHCS
31	1	DA-0131	HARNES FOR NEI POT
32	1	DA-0132	STAR WASHER M14 EXTERNAL TOOTH
33	1	DA-0133	SEGA SHAFT 270 DEG ACTIVE WHEEL

11-1 fig. 01

## 11-2 BRAKE AND ACCELERATOR UNIT

### WARNING

When working with the product, be sure to turn the power off. Working with the power on may cause an electric shock or short circuit. However, the unit must be switched on when using test mode. Do not touch any part of the unit except those areas indicated.

Be careful not to damage the wires. Damaged wires may cause an electric shock, short circuit or present a risk of fire.

This work should be performed by site maintenance personnel or other skilled professionals. Work performed by non-technical personnel can cause a severe accident such as an electric shock.

To prevent accidents while working or while operating the product after it has been installed, be sure not to conduct any procedures other than those given in this manual. There are cases in which procedures not covered in this manual require special tools and skills.

If a procedure not given in this manual is required, request service from the office given in this manual or from the point of purchase.

### STOP IMPORTANT

**Be sure to perform volume's move value setting in the Input Test in the Game Test Mode after replacing or adjusting the Volume.**

If the accelerator or brake pedals are not functioning correctly, you may need to adjust the positioning of the volume or replace it with a new one. In addition, you should apply grease to the gear contacts and spring parts once every three months.

When the accelerator pedal is not being pressed, the accelerator volume should have a value of 30H or less. When the pedal is being pressed, the value should be C0H or greater.

When the brake pedal is not being pressed, the value should be 35H or less. When the pedal is being pressed, it should be D0H or more. You can view these values in test mode. Note that the unit must be switched on to use test mode. Do not touch any part of the unit except those areas indicated when the unit is switch on, as there is a danger of electrical shock or short-circuit.

For this task, you will need a Phillips-head screwdriver (for M4, M5 screws).

## Adjusting Procedure

- 1 On the accelerator and brake pedal unit, remove the two truss screws and lift off the front cover.

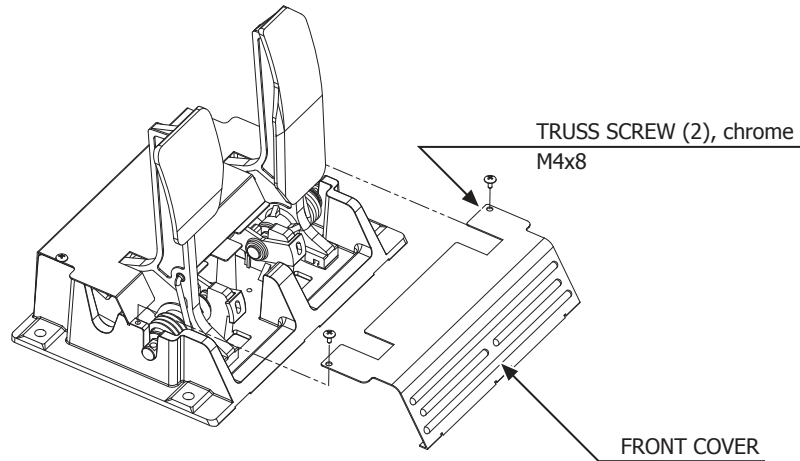

11-2 fig. 01

- 2 Loosen the single screw that secures the potentiobase, and move the base to adjust the volume values.

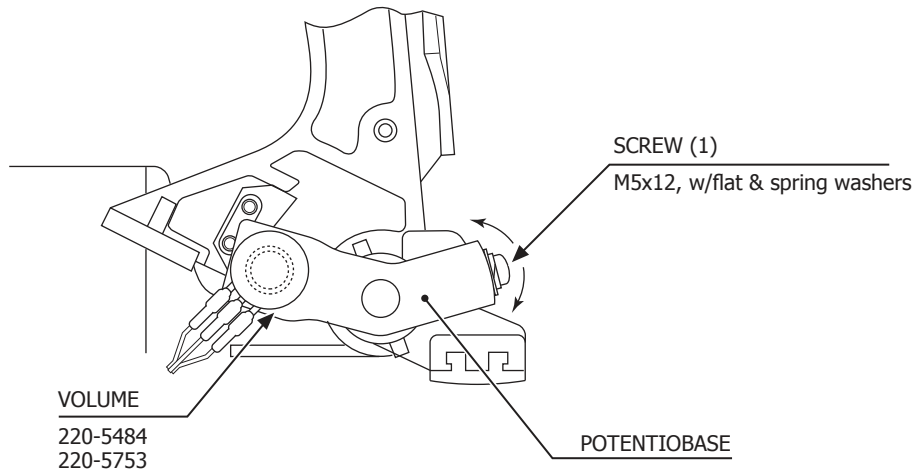

11-2 fig. 02

- 3 Secure the potentiobase.
- 4 Configure the volume values on the INPUT ASSIGNMENTS screen in Game Test Mode.
- 5 Check that the values change smoothly in response to pedal input.

## 11-3 ADJUSTING/REPLACING THE VOLUME POT

### Replacing the Volume

- 1 Remove power from the cabinet.
- 2 Remove the two screws and lift off the potentiometer cover.

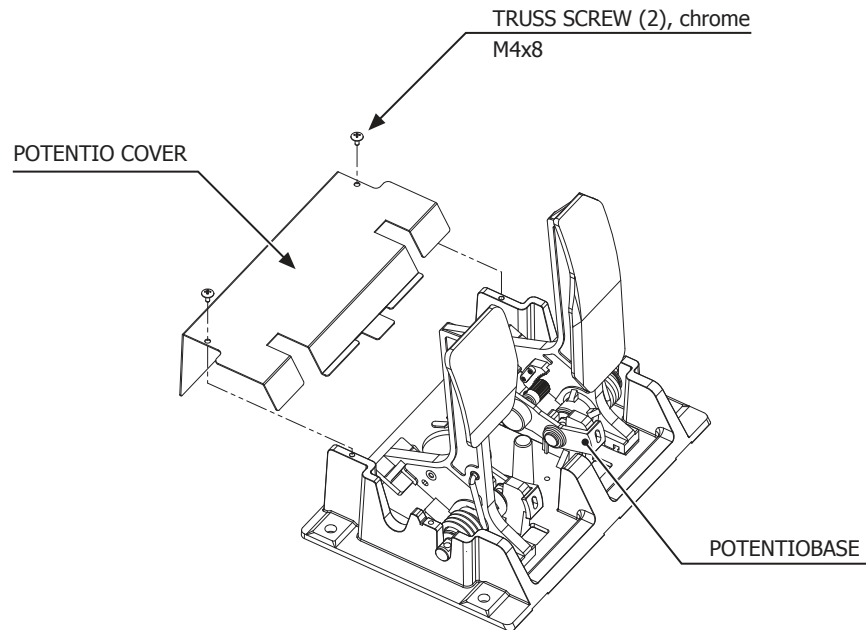

11-3 fig. 01

- 3 Detach the connector from the volume to be replaced.
- 4 Remove the single screw that secures the potentiometer base. (see 11-3 FIG. 01).
- 5 Without detaching the volume, remove the potentiometer base. (see 11-3 FIG 02).
- 6 The wire connected to the volume pot will be reused. Use a tool such as a pair of snips or cutters to remove the old heatshrink tubes which cover the contacts.

- 7** Use a soldering iron to melt the solder and separated the wires from the old volume pot. Be very careful when using a soldering iron.

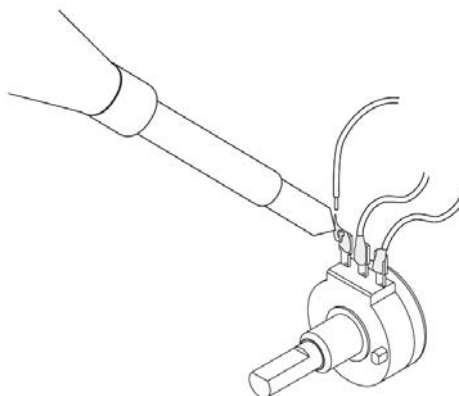

11-3 fig. 02

- 8** If the exposed conductive wire at the end is less than 5mm, use a tool such as a wire stripper or cutter to cut the wire insulation back to a workable length. Place new sleeving over the wire before resoldering them to the pot.

- 9** Once soldered, cover the bare contacts with the sleeving. If heatshrink is used, apply heat from an appropriate hot air blower to shrink the sleeving tightly over the contacts.

- 10** Reassemble the pot to the pot bracket by working in reverse order of these instructions. Refer to the POT VOLUME ADJUSTMENT section of this manual.

## 11-4 GREASING

### **STOP** IMPORTANT

Use only the specified grease. Using any other kind of grease can result in damage to parts.

Once every three months, you should apply grease to the gear contacts and spring parts. Use Grease Mate-brand spray grease (Part No.: 090-0066).

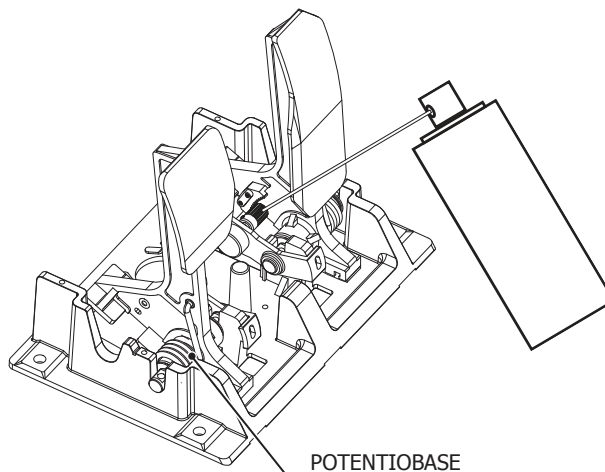

11-4 fig. 01

## 11-5 SHIFT LEVER

### WARNING

- When working with the product, be sure to turn the power off. Working with the power on may cause an electric shock or short circuit.
- Be careful not to damage the wires. Damaged wires may cause an electric shock, short circuit or present a risk of fire.

If the shift lever switch input does not function correctly on the INPUT TEST screen, the switch may need to be replaced. To carry out this maintenance, you must first remove the shift lever unit. For this task, you will need a tamper proof wrench (for M5 screws), /and a Phillips-head screwdriver (for M4 screws).

## 11-6 REMOVING THE SHIFT LEVER

- 1 Turn the power OFF
- 2 Using the M5 tamper proof wrench remove the four tamper proof screws, 1 located in each of the corner of the Shift Lever.
- 3 Gently lift out the Shift Lever to reveal the wiring harness, locate the plug connecting it to the Control panel and remove the connection. The Shift Lever can now be extracted.
- 4 When re-installing the Shift Lever follow the above instructions in the reverse order. At this time ensure that the 'DOWN' display appears on the upper part of the Shift Lever as shown.
- 5 After the Re-installation of the Shift Lever, be sure to check the INPUT TEST in the Game Test mode to determine it's correct operation.

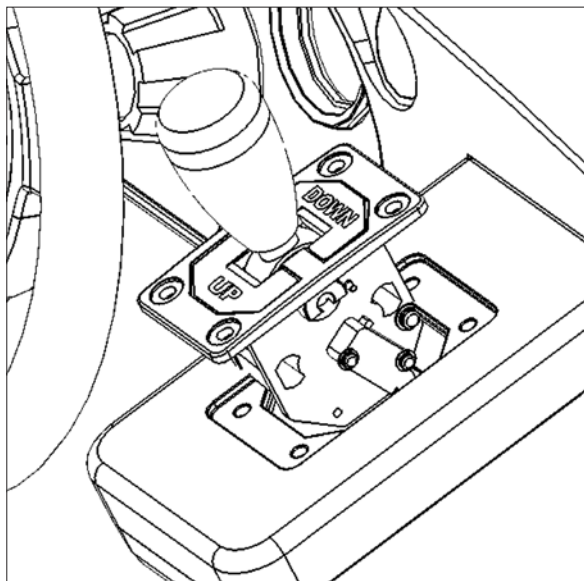

11-6 fig. 01

## 11-7 SHIFT SWITCH REPLACEMENT

Follow the instructions below to change the microswitch.

- 1** Unscrew and remove the M3x16 Self Tapping Screws which secure the microswitch to the Gear Shift base.
- 2** Remove the microswitch
- 3** Remove the wiring harness from the old microswitch and re-attach it to the replacement switch in the same manner

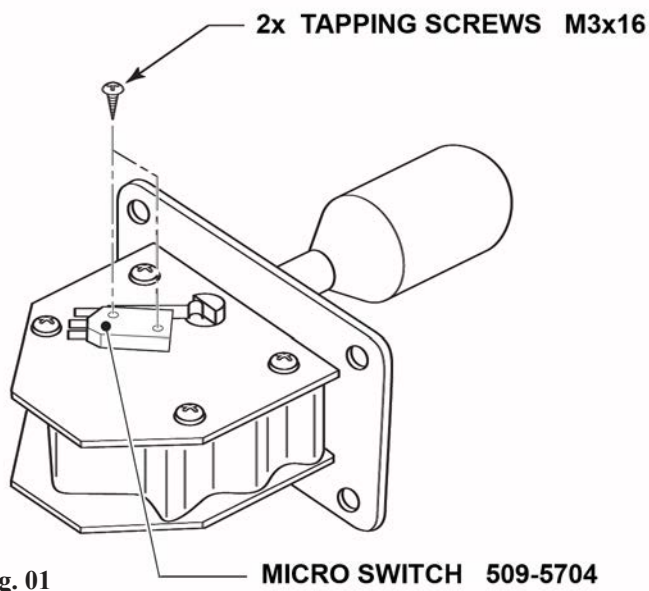

11-7 fig. 01

- 4** Using the M3x16 Self Tapping Screws, refit the replacement microswitch to the Gear Shift base.
- 5** The unit is now ready to be refitted into the Control Panel, to do this follow the instructions in reverse order

## 12 ACTIVE BILLBOARD

### WARNING

- When working with the product, be sure to turn the power off. Working with the power on may cause an electric shock or short circuit.
- Be careful not to damage the wires. Damaged wires may cause an electric shock, short circuit or present a risk of fire.
- Do not touch any parts that are not specified in these directions. Touching unspecified locations may lead to electric shock or cause short circuits.
- This work should be performed by site maintenance personnel or other skilled professionals. Work performed by non-technical personnel can cause a severe accident such as an electric shock.

### CAUTION

- When fastening plastic parts, be careful not to tighten screws and nuts excessively. Otherwise parts may be damaged, resulting in injuries from fragments, etc.
- Be careful not to get hand or finger caught when removing or attaching the parts.
- Disconnection and connection of connectors will be performed within the narrow cabinet space. Take due care not to scratch or otherwise injure yourself.
- Take care when carrying the removed ASSY BILLBOARD. Such heavy lifting carries a risk of injury to back or shoulders.
- When fastening plastic parts, be careful not to tighten screws or nuts excessively. If these are tightened to excess, parts could be damaged, resulting in injuries from fragments, etc.
- After the unit has been disassembled and reassembled again, check carefully that the unit has been reassembled correctly.

## 12-1 ACTIVE COMPONENTS - SERIAL LED

There are a number of components within the Assy Billboard which play an important role within game. Not only is the Billboard an attract piece but it also contains interactive components which relate to Game/Attract modes.

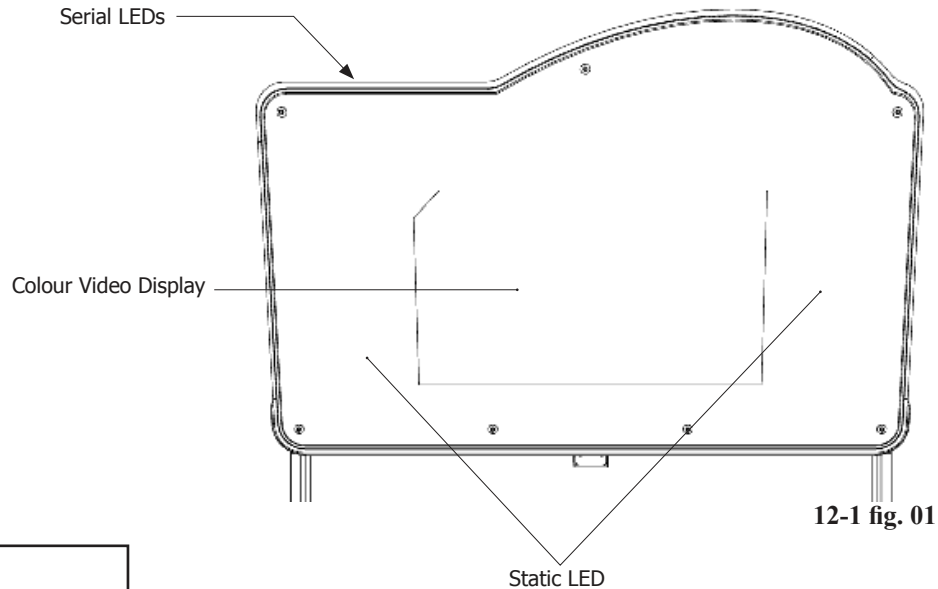

### Serial LED

The Serial LEDs positioned around the outer edge of the Billboard play several roles. Generated patterns indicate the car position (when teamed up in linked play) and also indicate various events throughout the game, including, Race Leader, Crashing, Overtake, etc.

The Serial LEDs also help to allocate the different car position colours. When a car position is set (Example :Car 1) then not only will the Serial LEDs illuminate blue but also the Engine compartment and Sear rear. This will give the overall appearance that the cabinet allocated to Car position 1 is BLUE.

Cabinet allocated to Car 1 will show the Serial LEDs as predominantly RED with a slight ORANGE trace running through it. Car 2 will show RED with a CYAN trace... and so on. Please see list below of colours and events displayed by the Serial LED.

CAR NO	BASE COLOUR	HIGHLIGHT COLOUR
1	BLUE	ORANGE
2	RED	CYAN
3	GREEN	WHITE
4	YELLOW	MAGENTA
5	CYAN	RED
6	MAGENTA	GREEN
7	WHITE	YELLOW
8	ORANGE	BLUE

### LIGHTING SEQUENCE EVENTS

Reprogrammed lighting sequences are written into the SLED controller software. These sequences are called up by the Game software during the course of the attract mode/game play.

Attract Mode	Attract mode lighting sequence using cabinet base colour.
Game Mode	Game play lighting sequence using cabinet ID base colour and Highlight colour.
Crash event	Flash sequence
Overtake event	Flash sequence
Race leader	Flash sequence

The Serial LEDs positioned throughout the cabinet are controlled by a single controller. The “Woo Fly” PCB. This PCB is situated behind the Control Panel between the Audio Amp and the Steering Motor.

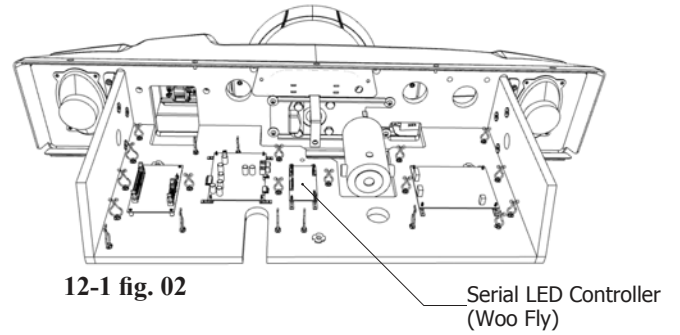

**Serial LED Driver PCB**



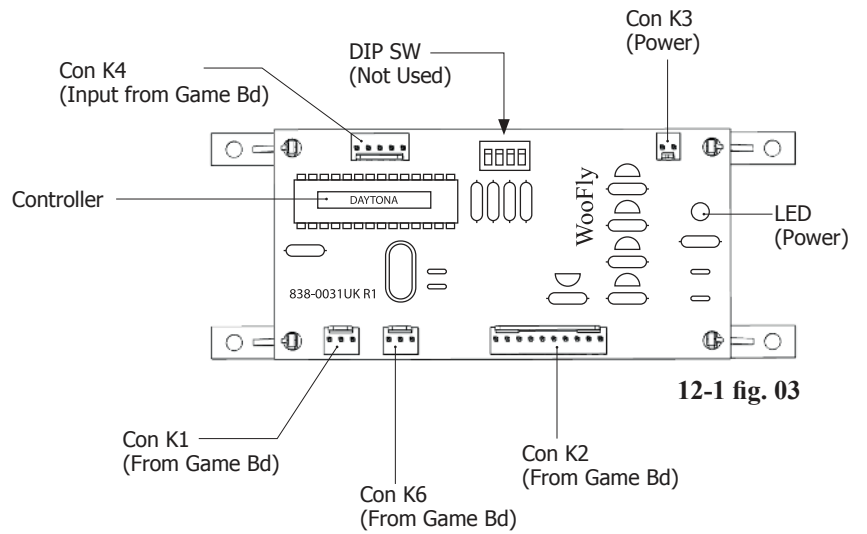

Pinout and connections



## 12-2 ACTIVE COMPONENTS - SECONDARY DISPLAY

The Secondary Display within the Billboard not only provides an attract sequence but also displays “live” game/race information.

### Example Screens

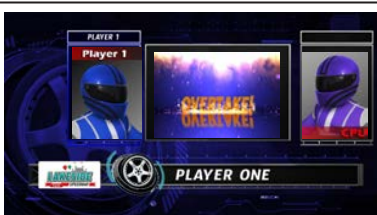
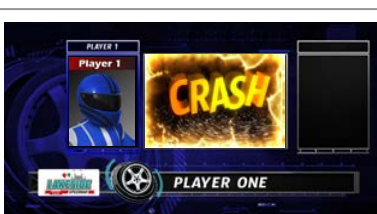
MAIN SCREEN	BILLBOARD	IMAGES
Attract Sequence	Logo, Attract Sequence +	
	Tournament dates (If enabled in Game Settings)	
	Live camera feeds from all linked cabinets	
In Race	Live player camera feed, race position and time.	
Overtake in race	Overtake animation/player camera feed(s) or driver graphics(s)	
Crash in race	Crash animation/player camera feed(s) or driver graphics(s)	

<p>New Race leader</p>	<p>New Race Leader/Player camera feed</p>	
<p>Champion in race</p>	<p>Live player camera feed, race position and time</p>	
<p>Tournament in race</p>	<p>Live player camera feed, race position and time</p>	
<p>Race over</p>	<p>Result Screen</p>	

## 13 COIN HANDLING

This product is supplied with either an electronic coin validator (particular to Europe) or a mechanical coin acceptor (particular to USA and Asia). Identify which coin acceptor is being used and consult the relevant information within this section of the manual.

### Handling the Coin Jam

If the coin is not rejected when the REJECT button is pressed, open the coin chute door and open the selector gate. After removing the jammed coin, put a normal coin in and check to see that the selector correctly functions.

### 13-1 CLEANING THE COIN SELECTOR

#### **STOP** IMPORTANT

- Remove and clean smears by using a soft cloth dipped in water or diluted chemical detergent and then squeezed dry.
- Never apply machine oil, etc. to the Coin Selector.
- After cleaning the Coin Selector, insert a regular coin in the normal working status and ensure that the selector correctly functions.

The Coin Selector should be cleaned once every 3 months.  
When cleaning, follow the procedure below:

- 1 Turn the power for the machine OFF. Open the Coin Chute Door
- 2 Remove the Coin Selector from the Coin Chute Door
- 3 Open the gate and dust off by using a soft brush (Small soft Paint Brush, etc.)

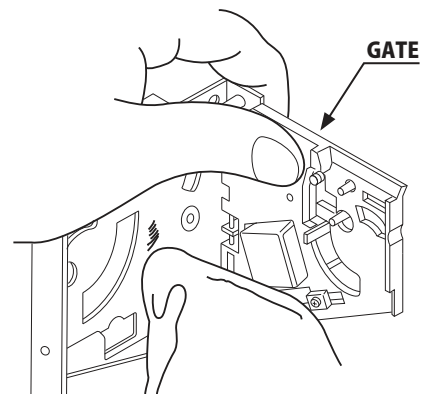

13-1 fig. 01

**CLEANING THE COIN SELECTOR (MECHANICAL).**

**1** Remove and clean smears by using a soft cloth dipped in water or diluted chemical detergent and then squeezed dry.

**2** Remove the CRADLE.. When removing the retaining ring (E ring) be very careful so as not to bend the rotary shaft.

**3** Remove stain from the rotary shaft and shaft receiving portions by wiping off with a soft cloth. etc.

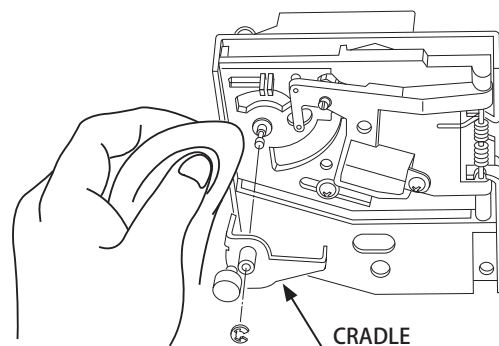

13-1 fig. 02

**4** After wiping off as per previous step, further apply a dry cloth to completely dry the Coin Selector.

**Coin Insertion Test**

Once every month, when performing the Coin SW Test, simultaneously check the following:

Does the Coin Meter count satisfactorily?

Does the coin drop into the cashbox correctly?

Is the coin rejected when inserted while keeping the REJECT Button pressed down?

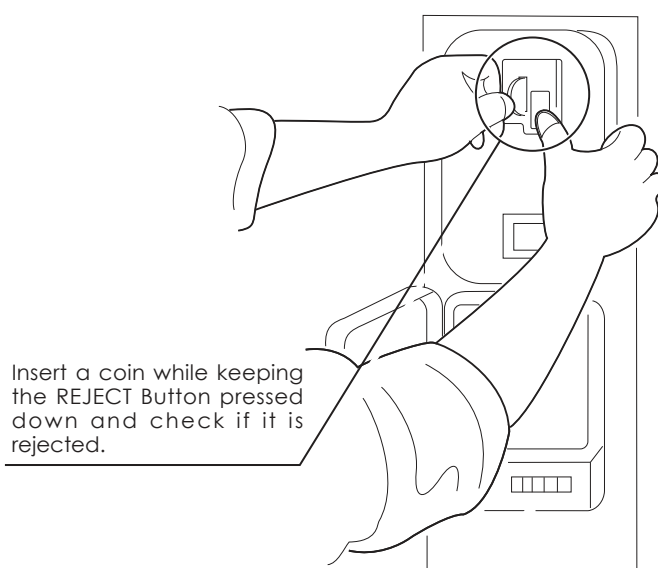

13-1 fig. 03

## CLEANING THE COIN SELECTOR (SR3/NRI) TYPE

- 1 Remove and clean smears by using a damp soft cloth dipped in water. DO NOT use any diluted chemical detergent or cleansing agent as this will impair the workings of the component.

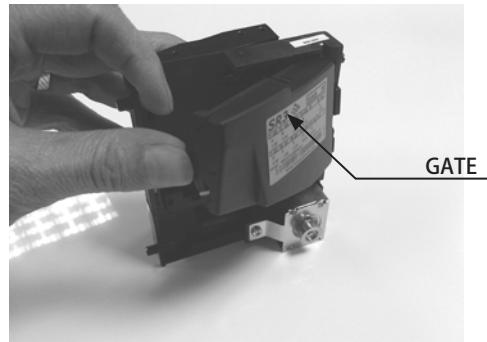

13-01 fig. 04

- 2 Open the reject gate to gain access to the rundown path.

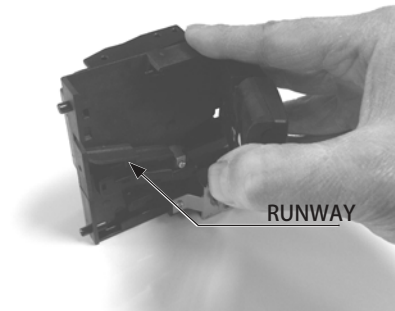

13-01 fig. 05

- 3 Remove the dirt and stains from the runway by wiping off with a soft damp cloth.

- 4 After wiping off as per previous step, further apply a dry cloth to completely dry the coin Selector.



13-01 fig. 06

Pictures for illustration purposes only..  
Model shown is SR3 Coin validator. Visual differences  
between models but process remain the same.

## 13-2 FAULT FINDING

### Fault Finding

The following information is presented for customers' guidance in rectifying a fault but does not cover all possible causes.

All acceptors with electronic faults should be returned to an approved service centre for repair.

13

COIN HANDLING

SYMPTOM	INVESTIGATE	POSSIBLE CAUSE
Acceptor does not work (all coins reject)	Connector	Poor Contact
		Loose Wire
	Power Supply	Not switched on
		Incorrect voltage
		Inadequate current
		Rise time too slow
	Inhibit all inputs	Acceptor Inhibited
	Accept gate	Gate not free or dislocated
	Accept channel	Obstruction
	Reject gate	Not fully closed
	LED on rear cover RED	EEPROM chksm error
		SR Sensor fault
		Credit opto fault
Credit sensor blocked		
Reject lever pressed		
LED on rear cover YELLOW	Reinstall power	
Poor Acceptance	Power Supply	Voltage less than 10v (Voltage drops when coil engages)
	Accept gate	Gate jam or dislocated
	Connector	Loose
	Coin rundown	Dirty
	Bank Select	Both banks enabled
Coin stick or jam in acceptor.	Accept channel	Acceptor dirty or may have some damage
	Accept gate	
	Reject gate	
A true coin type rejects	Label	Coin not programmed
No accept signal	Connector	Loose or broken wire
	Accept channel	Path dirty or obstructed

## 13-3 ADJUSTING THE PRICE OF PLAY (EXCEL)

### STOP IMPORTANT

- SEGA amusement products are fitted with either an EXCEL CREDIT PCB or a VTS (Volume, Test, Service) PCB. Both these components operate coin handling in the same way. Only one of these components are fitted.
- The price of play is determined by the configuration of switches located on either an EXCEL board or VTS board. The type of board used is determined by product location. Switch settings for both types of board remain the same.

This product comes equipped with a Money Controls SR3 Coin Acceptor. To adjust the price of play ALL credit setting are adjusted via the EXCEL CREDIT BOARD.

#### IMPORTANT!

The CREDIT SETTINGS within the SYSTEM TEST MODE must be set to 1 coin 1 credit to allow the CREDIT BOARD to function correctly.

The VTS BD has a built in Credit Board. This is controlled by 2 DIL Switches. These allow the operator to select the price of play, type of coin acceptor and region.

#### EXCEL Credit Board

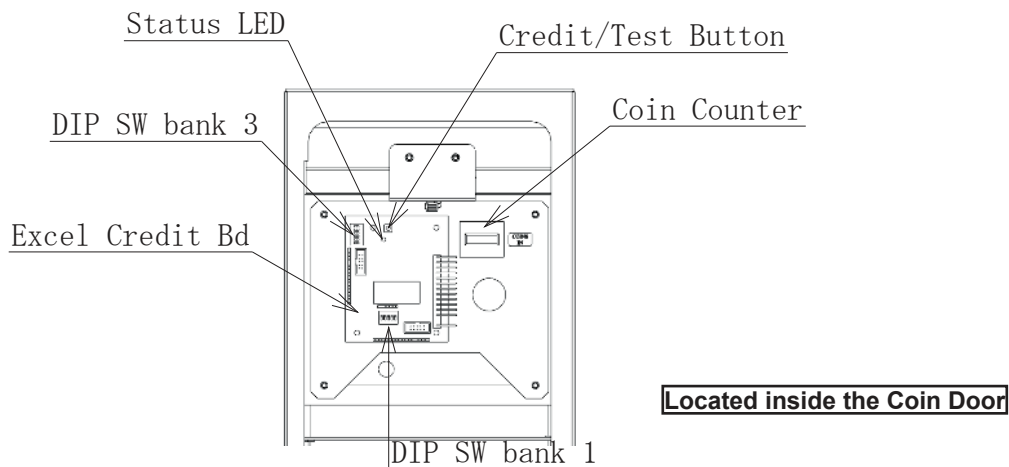

13-3 fig. 01

DIL SW3 (Regional Settings)

Adjust these switches to specify the type of Coin Acceptor used and currency.

Default = SW1&SW2 ON - NRI in parallel mode, Sterling.

TEST BUTTON

Provides an unaccountable service credit

Status LED

Flashes when functioning.

CHANNEL 1

To Coin Acceptor (SR3 TYPE.)

DIL SW1 (credit settings)

Adjust to required price of pay.

COIN COUNTER

Counts Coins - 1 pluse per 0.10 unit.

# 13-4 ADJUSTING THE PRICE COMMON (USA)

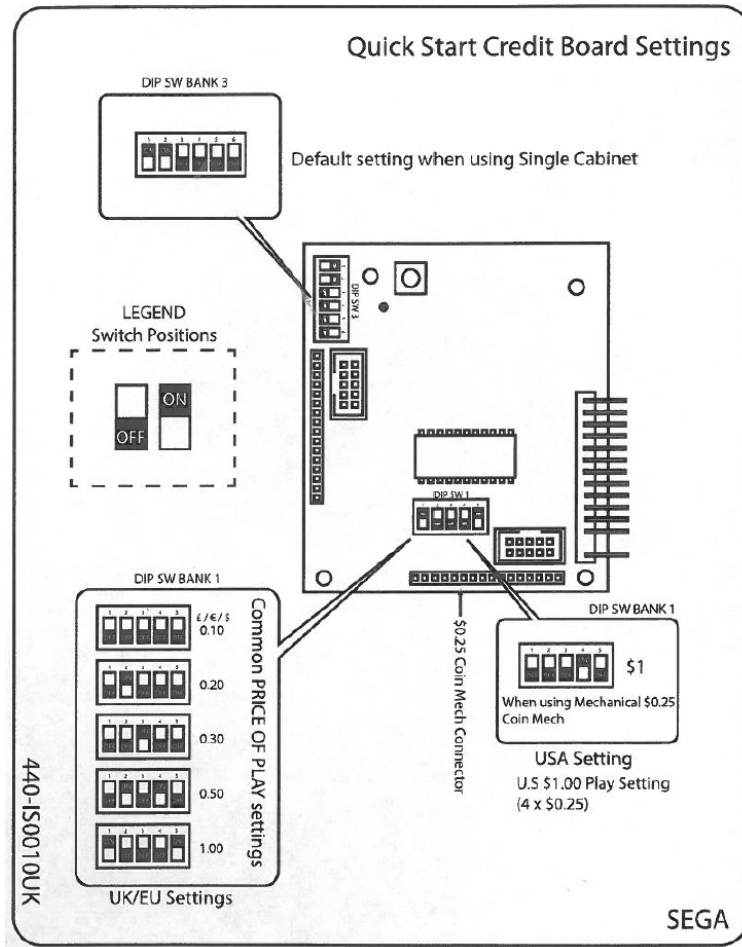

13-4 fig. 01

DIL SWITCH BANK ONE (5 way SW1)						
Item	Price	SW1	SW2	SW3	SW4	SW5
1	25cent	OFF	OFF	OFF	OFF	OFF
3	50cent	OFF	ON	OFF	OFF	OFF
5	75cent	OFF	OFF	ON	OFF	OFF
9	\$1.00	OFF	OFF	OFF	ON	OFF
16	\$2.00	ON	ON	ON	ON	OFF
DIL SWITCH BANK TWO (6 way SW3)						
Type	SW1	SW2	SW3	SW4	SW5	SW6
USA	OFF	OFF	OFF	OFF	OFF	OFF

13-4 Tab. 01

## QUICK VIEW SETTINGS

### SEGA EXCEL CREDIT BOARD PRICE OF PLAY SETTINGS

Play Price £ / € / \$	Bonus adder	BANK 1						
		1	2	3	4	5		
1 0.10	No Bonus	OFF	OFF	OFF	OFF	OFF		
2 0.10	0.50 = 6 plays	ON	OFF	OFF	OFF	OFF		
3 0.20	No Bonus	OFF	ON	OFF	OFF	OFF		
4 0.20	0.50 = 3 plays	1.00 = 6 plays	2.00 = 12 plays	ON	ON	OFF	OFF	OFF
5 0.30	No Bonus	OFF	OFF	ON	OFF	OFF		
6 0.30	-	1.00 = 4 plays	2.00 = 8 plays	ON	OFF	ON	OFF	OFF
7 0.30	0.50 = 2 plays	1.00 = 4 plays	-	OFF	ON	ON	OFF	OFF
8 0.40	No Bonus	OFF	OFF	OFF	ON	OFF		
8 0.40	-	1.00 = 3 play	2.00 = 6 plays	ON	OFF	OFF	ON	OFF
9 0.50	No Bonus	OFF	ON	OFF	ON	OFF		
10 0.50	-	1.00 = 3 plays	2.00 = 6 plays	ON	ON	OFF	ON	OFF
11 0.50	-	1.00 = 2 plays	2.00 = 5 plays	OFF	OFF	ON	ON	OFF
12 0.60	No Bonus	ON	OFF	ON	ON	OFF		
13 0.60	-	1.00 = 2 plays	2.00 = 4 plays	OFF	ON	ON	ON	OFF
14 0.80	No Bonus	ON	ON	ON	ON	OFF		
15 0.80	-	1.50 = 2 plays	-	OFF	OFF	OFF	OFF	ON
16 1.00	No Bonus	ON	OFF	OFF	OFF	ON		
17 1.00	-	-	2.00 = 3 plays	OFF	ON	OFF	OFF	ON
18 1.00	-	2.00 = 2 plays	4.00 = 5 plays	ON	ON	OFF	OFF	ON
19 1.50	No Bonus	OFF	OFF	ON	OFF	ON		
20 1.50	-	2.00 = 2 plays	-					
21 2.00	No Bonus	OFF	ON	ON	OFF	ON		
22 2.00	-	-	5.00 = 3 plays					
23 3.00	No Bonus	OFF	OFF	OFF	ON	ON		
24 3.00	-	-	5.00 = 2 plays	ON	OFF	OFF	ON	ON
25 5.00	No Bonus	OFF	ON	OFF	ON	ON		
26 5.00	-	-	10.00 = 3 plays	ON	ON	OFF	ON	ON
27 7.50	No Bonus	OFF	OFF	ON	ON	ON		
28 7.50	-	-	10.00 = 2 plays	ON	OFF	ON	ON	ON
29 10.00	No Bonus	OFF	ON	ON	ON	ON		
30 FREE	Free Play	ON	ON	ON	ON	ON		

\*All shaded areas are default price of play values with no additional bonuses

13-4 Tab. 02

Country		Setting	Switch 3 Setting					Credit Board Mode Settings Switch 3									
			SW1	SW2	SW3	SW4	SW5	SW6	Coin Validator Programming					C120/SR3 Only			
			COIN1	COIN2	COIN3	COIN4	COIN5	COIN6	COIN7	COIN8	COIN9	COIN10	COIN11	COIN12			
UK	Coin Controls C220 Parallel	OFF	£1	50p new	20p	10p	-	50p old	-	-	-	-	-	-			
UK	Coin Controls C220 Binary	ON	£1	50p new	20p	10p	-	50p old	-	£2	-	-	-	-			
UK	Coin Controls C220 Binary	OFF	£1	50p new	20p	10p	-	£2	-	50p old	-	-	-	-			
UK	Coin Controls SR3 Parallel	ON	£1	50p new	20p	10p	-	£2	-	50p old	-	-	-	-			
UK	Coin Controls SR3 Parallel	OFF	£2	£1	50p new	20p	10p	-	-	-	50p old	-	-	-			
UK	Coin Controls SR3 Parallel	OFF	€2	€1	50p new	20p	10p	-	-	-	-	-	-	-			
UK	Coin Controls SR3 Parallel	OFF	£1	£2	20p	10p	50p new	50p old	-	-	-	-	-	-			
UK	Mars ME/MS 111 Parallel	ON	£1	£2	20p	10p	50p new	50p old	-	-	-	-	-	-			
UK	NRI Parallel	OFF	10p	20p	50p	£1	£2	-	-	-	-	-	-	-			
Belgium	Parallel	ON	-	50Bfr	20Bfr	5Bfr	-	-	-	-	-	-	-	-			
Holland	Parallel	OFF	-	5NLG	2.5NLG	1NLG	-	-	-	-	-	-	-	-			
Austria	SR3 Parallel	ON	20Sch	10Sch	5Sch	1Sch	-	-	-	-	-	-	-	-			
Spain	Coin Controls C220 Binary	OFF	500Pta	200Pta	100Pta	50Pta	25Pta	200Pt old	50Pta old	25Pta old	-	50Pta old	25Pta old	-			
Spain	SR3/NRI Parallel	ON	500Pta	200Pta	100Pta	50Pta	25Pta	-	-	200Pta	-	-	-	-			
Spain	Coin Controls C220 Parallel	OFF	100Pta	50Pta new	-	25Pta new	-	50Pta old	-	25Pta old	-	-	-	-			
Portugal Euro	Parallel	ON	200Es €1	100Es 50¢	50Es	-	-	-	-	-	-	-	-	-			
	TBA		TBA														
				OFF													
	Channels		TBA	ON													
			Direct Mode	OFF													
			2 channel Mode	ON													

**Please Note**  
The credit board automatically sets the validator for parallel and binary operation through an output on pin 8 of the 17 way pinstrip. For the feature to work it is necessary for the validator interconnecting cable to include at wire at this position

Note: These switch settings are under constant review and may change due to world currency updates.

Set SW 1 according to the option settings found in the relevant Price of Play Settings Table on the following pages.

Set SW 3 on the VTS /Excel board as shown in the table above corresponding to the country required.

13-4 Tab. 03

## 14 LAMPS AND LIGHTING

### ⚠ WARNING

- When working with the product, be sure to turn the power off. Working with the power on may cause an electric shock or short circuit.
- You may get burned by a hot fluorescent lamp or other lamps. Pay full attention to the lamps when performing the work.
- Be sure to use lamps of the designated rating. Using lamps of undesignated rating can cause a fire or malfunctioning.
- There is the danger of short circuits or smoke generation due to deterioration of insulation in lighting fixtures resulting from age deterioration. Check for anomalies such as the following: Does it smell like something is burning? Is there socket discoloration? Are any lamps being replaced frequently? Do lamps not go on properly?

### ⚠ CAUTION

The Coin Door Lamp utilises a 12v 1.2w Wedge Bulb. It is important that you replace this bulb or any other bulb of that of the same voltage and rating. Failing to observe this caution may result in PCB failure or possible fire hazard.

## 14-1 COIN DOOR LAMP

Step 1. Open the Coin Door and locate the Lamp Housing directly behind the Coin Insert Bezel.

Lamp Housing

Step 2. Hold the Lamp Housing firmly between your index finger and thumb and gently pull upwards. Do Not try to remove the Lamp Housing whilst holding the bulb as the bulb may break causing injury.

Step 3. Once the Lamp Housing has been removed, carefully hold the bulb between your fingers and pull the Lamp Housing away.

Do not twist either bulb or Lamp Housing whilst removing the bulb as this may cause damage to both bulb and or Housing.

Type: Wedge Bulb - 12v, 1.2w

Step 4. Simply push-fit a replacement bulb of the same type and follow these steps in reverse to refit.

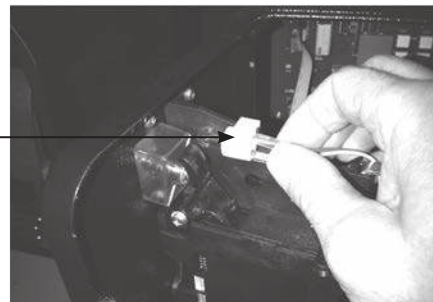

14-1 fig. 01



14-1 fig. 02

## 14-2 START/VIEW BUTTON PANEL

- 1 Turn off the power.
- 2 Remove the (4) M4x16 Hex Key machine screws from the START/VIEW Button Panel.

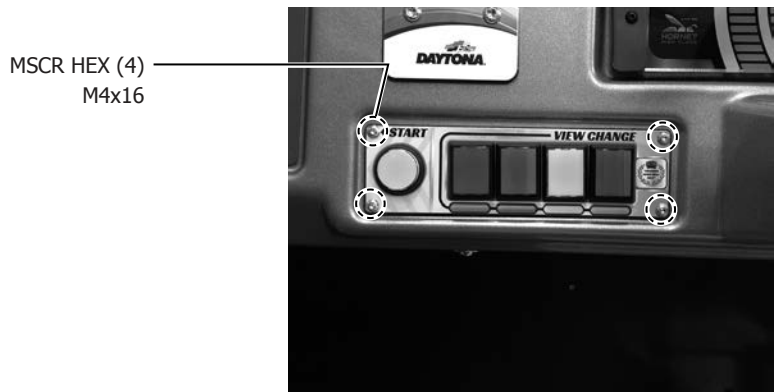

14-2 fig. 01

- 3 Remove the START/VIEW button panel part way to gain access to the connector. Disconnect the connector and remove.

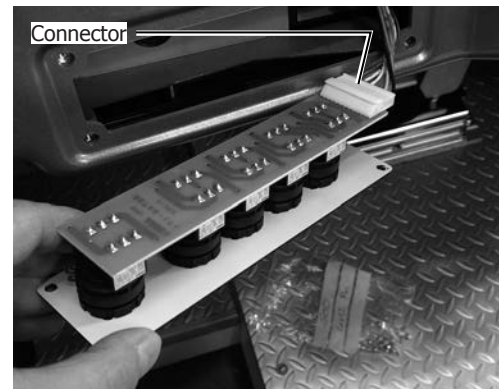

14-2 fig. 02

- 4 There is a metal clasp fitted at the base of each button. Rotate this metal clasp to unlock it, then remove the printed circuit board from the button plate.

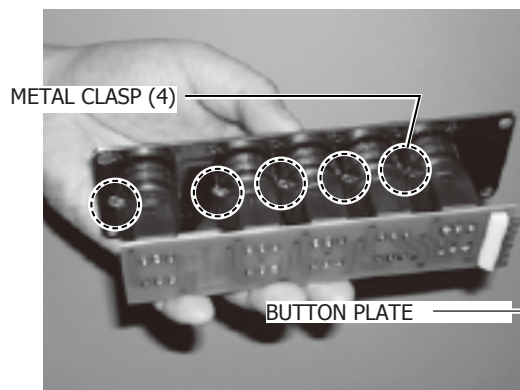

14-2 fig. 03

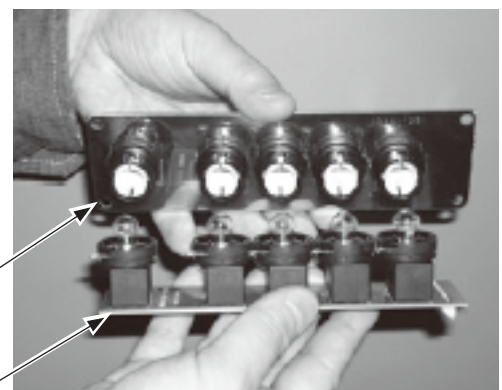

14-2 fig. 04

- 
- 5** Carefully press on the lamp and turn it counter clockwise to remove.

LAMP 6.3V, 1W

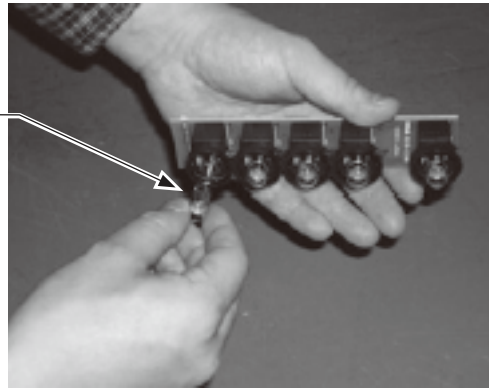

14-2 fig. 05

- 
- 6** Follow these instructions in reverse order to re-assemble and re-fit the START/VIEW Button Panel..

## 14-3 CONTROL PANEL DIALS

**1** Turn off the power.

**2** Remove the (4) M4x16 Hex Key machine screws from the REAR ACCESS PANEL. Remove the ACCESS PANEL and carefully disconnect the GAME BD.



14-3 fig. 01



14-3 fig. 02

**3** Remove the (4) M4x16 Hex Key machine screws from the SASH BKT (DA1007UK) situated at the rear of the cabinet.

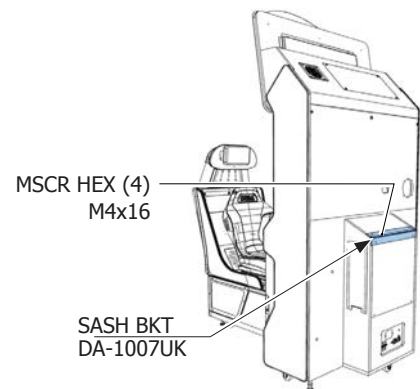

14-3 fig. 03

**3** Carefully lower and disconnect the connections going to/from the ASSY GAME BD. Remove the ASSY GAME BD and place to one side.

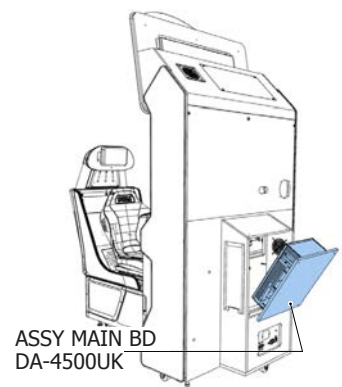

14-3 fig. 04

- 4** Looking through the service access to the back of the CONTROL PANEL you will see the PLATE DIALS BACK LIT (DA-2015UK). Unscrew the (2) fixings positioned at either end of the PLATE DIALS BACK LIT, disconnect the harness and remove.

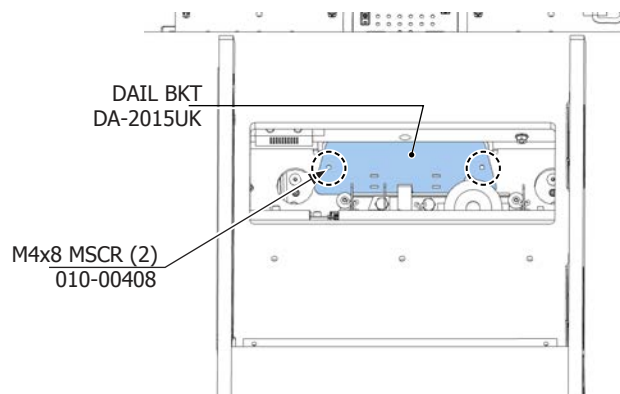

14-3 fig. 05

- 5** Using a pair of cutters, carefully cut the (2) cable ties. Once removed, peel off the self adhesive LED tape and discard.

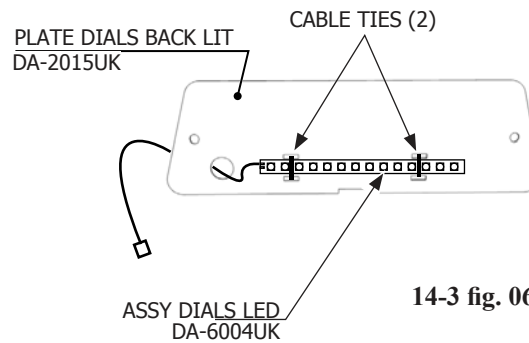

14-3 fig. 06

- 6** Replace the ASSY DIALS LED (DA-6004UK). Secure with (2) new cable ties and re-assemble following these instructions in reverse order.

## 14-4 FOOTWELL LIGHTING

The FOOTWELL LIGHTING provides an ambient coloured lighting effect to the FOOTWELL area. When the cabinets are joined in a network, each cabinet is assigned a different colour by means of illuminating various lighting around the cabinet. The FOOTWELL lighting forms part of this group.

- 1 Turn off the power.
- 2 Locate the Footwell lighting cover positioned beneath the Control Panel.

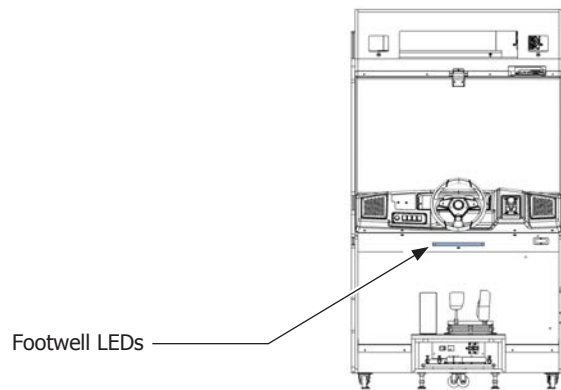

14-4 fig. 01

- 3 Remove the (2) M4x25 HEX KEY MSCR located at either end of the FOOTWELL LIGHTING COVER. Locate the LED strip and carefully peel away from the surface.

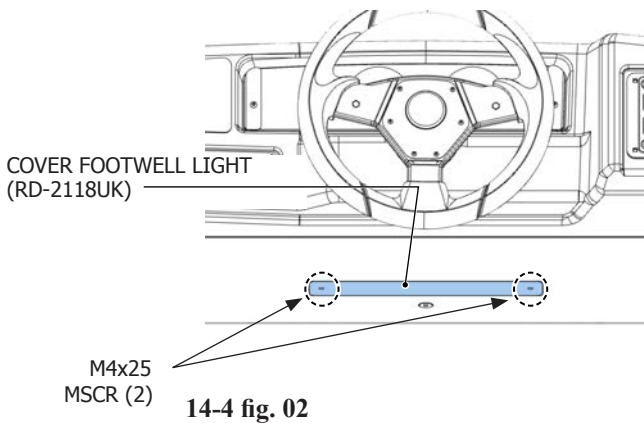

14-4 fig. 02

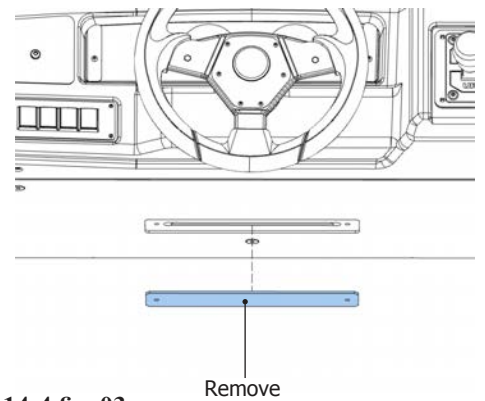

14-4 fig. 03

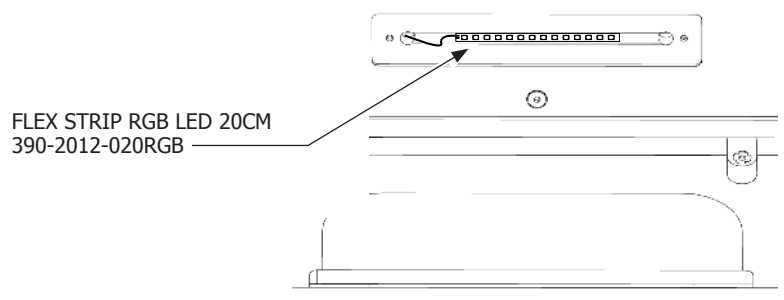

14-4 fig. 04

**4** Remove the BACK DOOR of the DISPLAY CABINET. Locate and disconnect the connector for the FOOTWELL LED STRIP.

(2) Unlock the Back door using the back door key (supplied)

(1) Remove the (2) M4x30 fixings from the upper corners of the Back Door

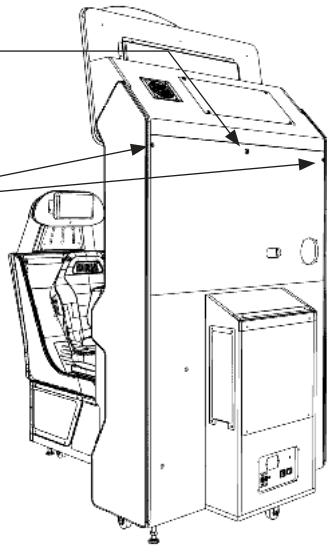

14-4 fig. 05

(3) Carefully remove the back door.  
\*The back door is heavy. Please take care upon removal.

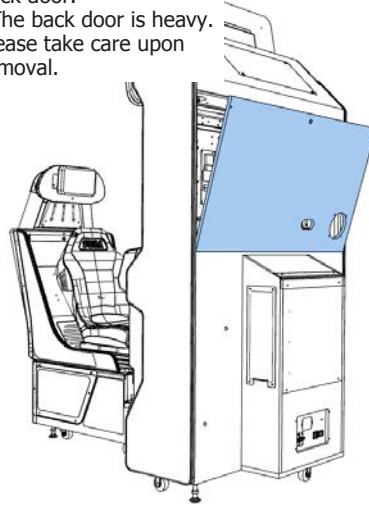

14-4 fig. 06

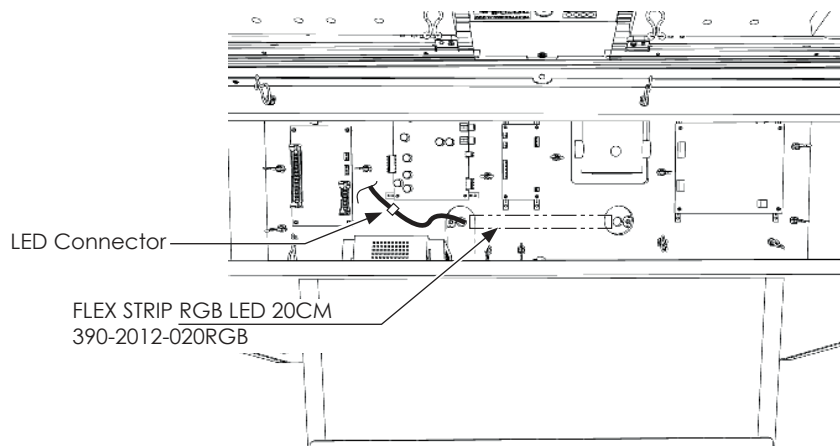

14-4 fig. 07

**5** Carefully pull the LED STRIP through the access hole and discard. Fit a NEW LED STRIP by following these instructions in reverse order.

## 14-5 ENGINE LIGHTING UPPER

These instructions illustrate the removal of the LED LIGHTING strips positioned on the left hand side of the cabinet. The process for removing the LED LIGHTING strips positioned on the right hand side of the cabinet are the same.

**1** Turn off the power.

**2** Locate the FRAME WINDOW REAR (DA-3312UK)

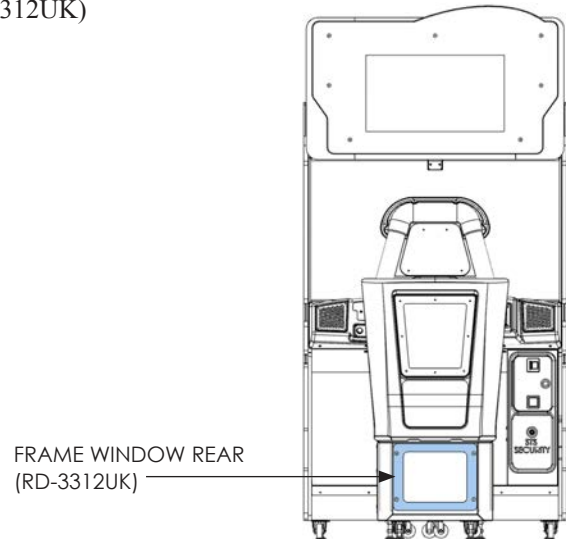

14-5 fig. 01

**3** Remove the (4) M4x16 SKT BH BLK and fitted washers from the four corners of the WINDOW FRAME REAR. Carefully remove the frame and WINDOW REAR (DA-3311UK)

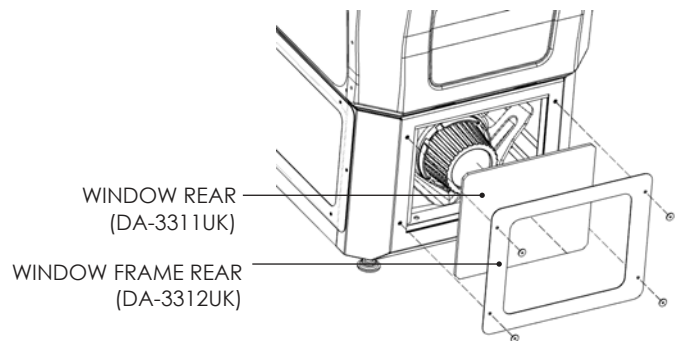

14-5 fig. 02

**4** Remove the (3) M4 FLANG NUTS which secure part of the WINDOW FRAME REAR.

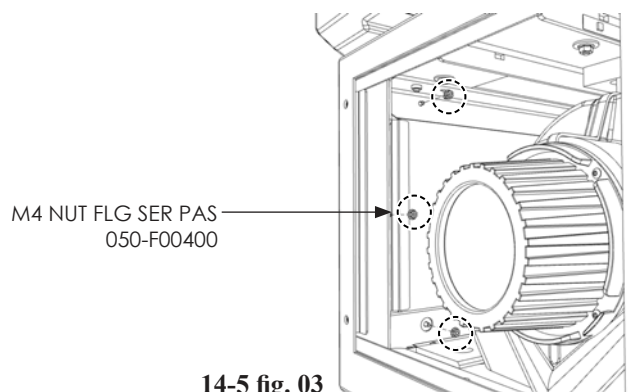

14-5 fig. 03

- 5** Remove the (3) M4x25 SKT BH BLK and fitted washers located on the outside edge of the WINDOW FRAME SIDE L (DA-3315UK) or WINDOW FRAME SIDE R (DA-3316UK)

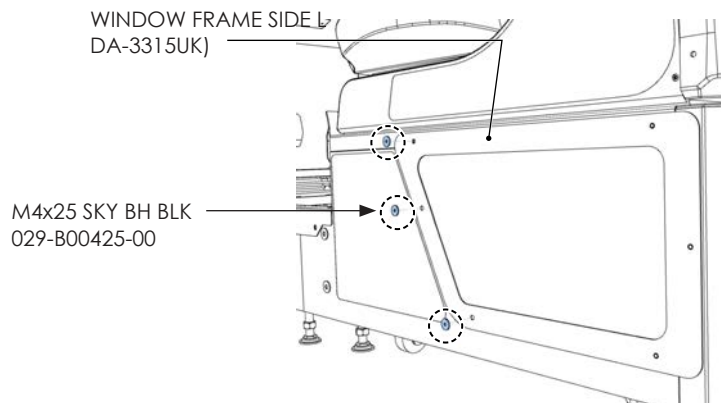

14-5 fig. 04

- 6** Once all fixings have been removed, carefully remove the WINDOW FRAME SIDE L and THE WINDOW SIDE.

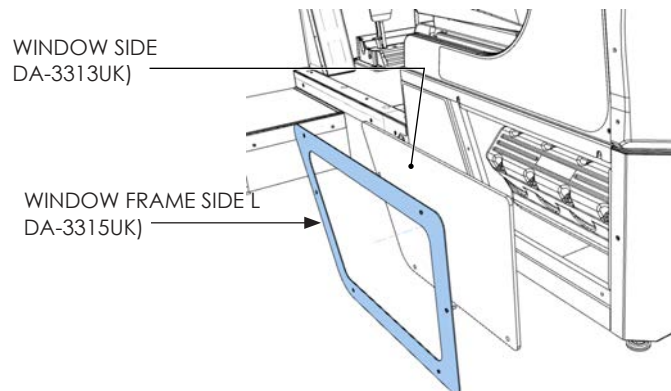

14-5 fig. 05

- 7** Located the ASSY LED ENGINE UPPER.

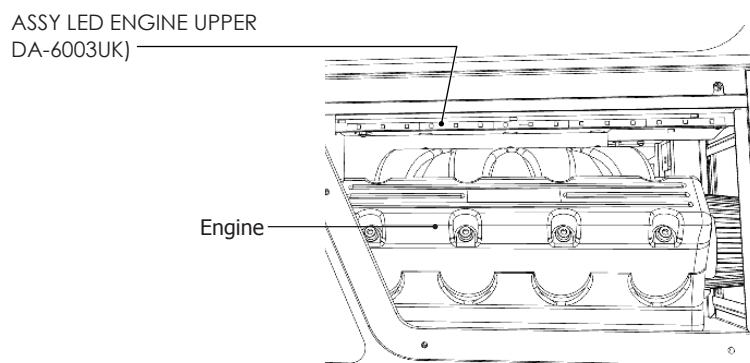

14-5 fig. 06

- 
- 8** Carefully peel away the LED strip and gently pull on the harness until the connector at the end of the harness is visible. Disconnect the harness and replace.

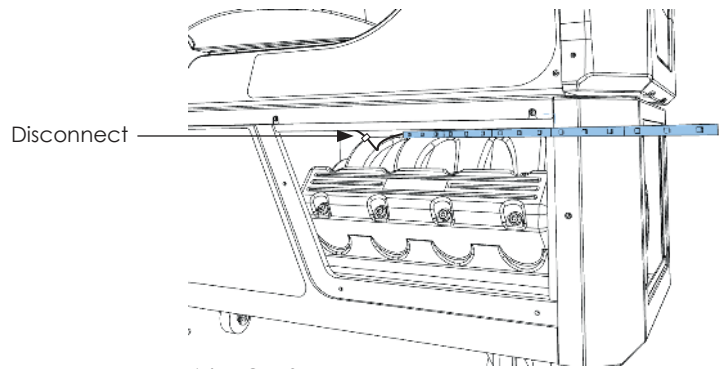

**14-5 fig. 07**

- 
- 9** Remove the protective covering from the adhesive side of the “NEW” LED strip and carefully adhere into position. Reconnect the connector and follow these instructions in reverse order to reassemble.

## 14-6 ENGINE LIGHTING LOWER

- 1 Follow procedures 1 to 6 in section 13-5 ENGINE LIGHTING UPPER.
- 2 Locate the LIGHT COVER BASE UPPER (DA-3608UK) and remove the (4) N6x1/2" S/TAP FLG BLK (012-P03512-FB)

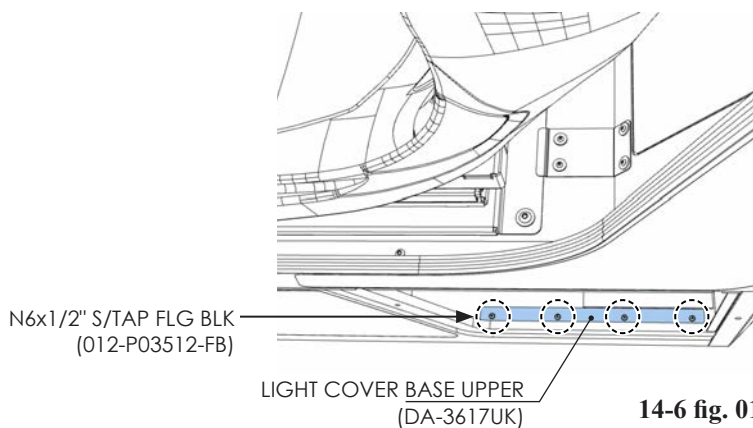

- 3 Locate the ASSY LED ENGINE LOWER (DA-6005UK). Carefully peel away the LED strip. Pull gently upon the harness to reveal the connector. Disconnect the connector and replace. Follow these instructions in reverse order to reassemble.

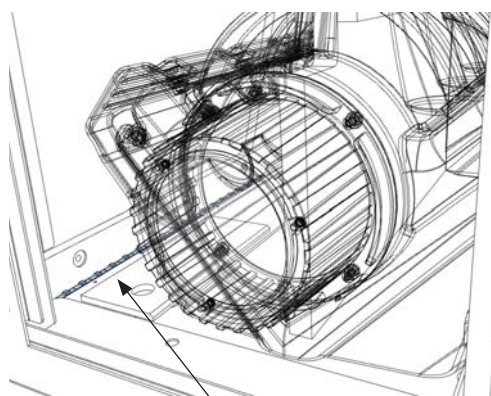

ASSY LED ENGINE LOWER  
(DA-6005UK)

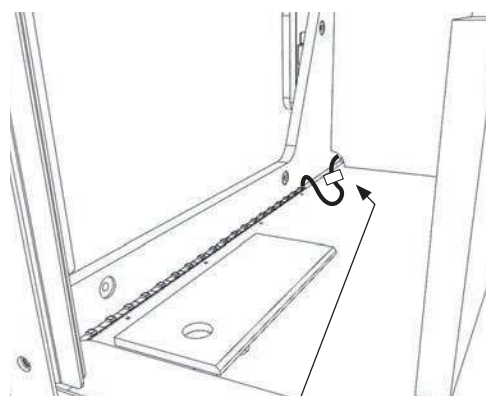

## 14-7 SEAT BACK LIGHTING

1 Turn off the power.

2 Locate the SEAT MOULD REAR

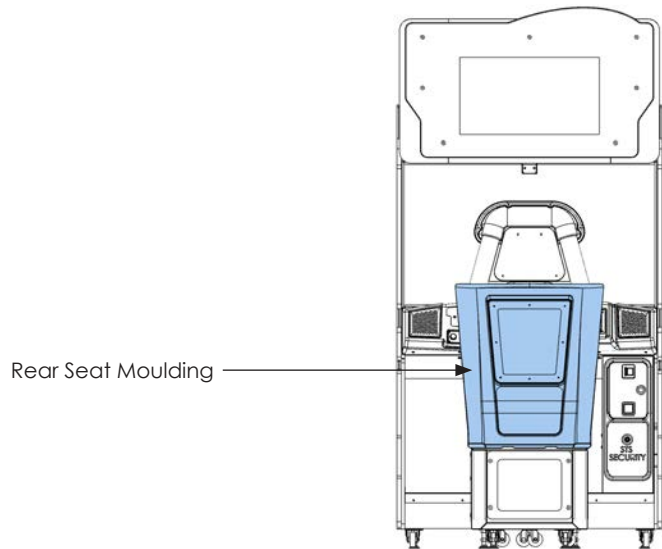

3 Remove the (5) M4x16 SKT BH PAS which secure the CLOSING BRKT TOP (DA-3424UK). Remove CLOSING BRKT TOP (DA-3424UK)

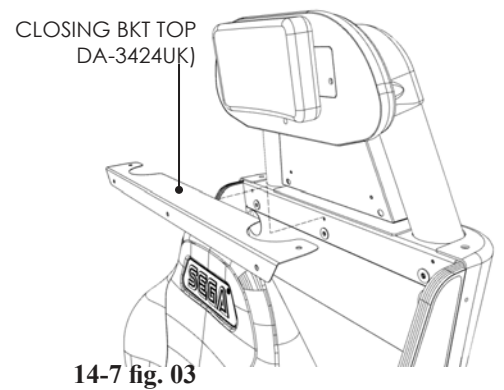
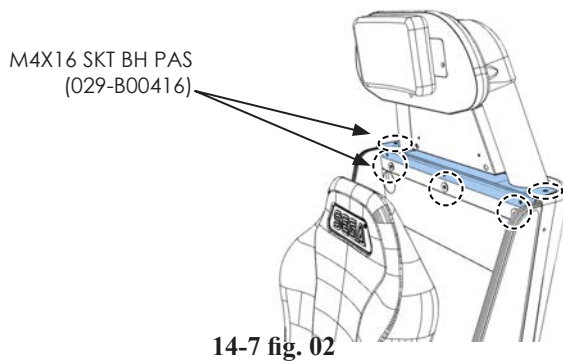

4 Remove the (8) M4x16 SKT BH PAS which secure the SEAT MOULD REAR (DA-3401UK).

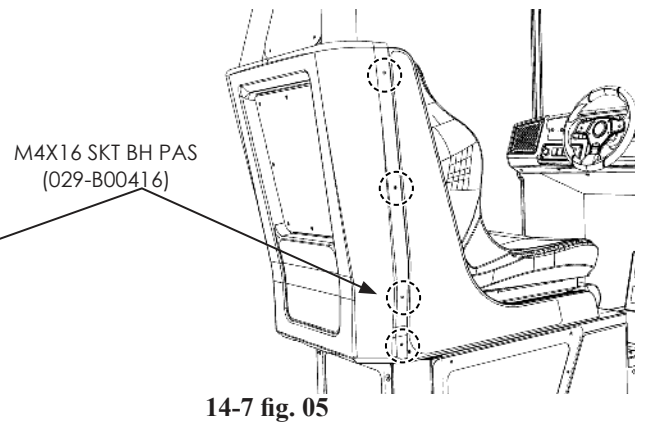
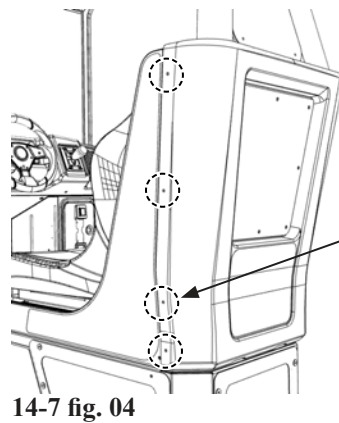

- 5** Carefully remove the SEAT MOULD REAR from the rear of the ASSY SEAT. There are (2) locating lugs at the bottom edge. It may be necessary to manipulate this area to free from location.

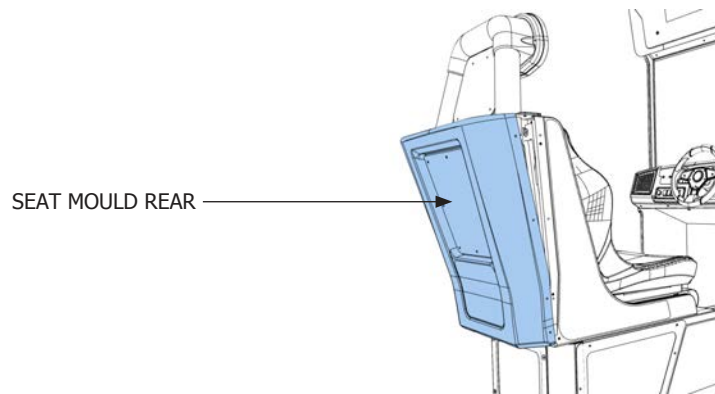

14-7 fig. 06

- 6** Remove the (4) M4x16 SKT BH BLK and fitted washers from the four corners of the WINDOW FRAME REAR. Carefully remove the frame and WINDOW REAR (DA-3311UK)

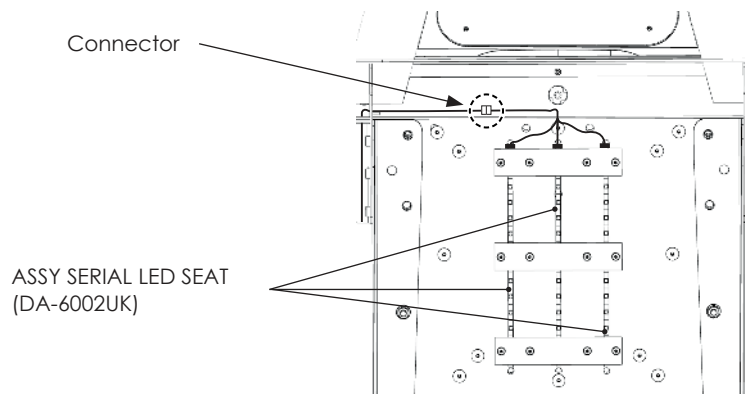

14-7 fig. 07

- 7** Locate and remove the (12) N8x1/2" S/Tap FLG BLK from the three LED COVER BACK PANELS. Remove the LED COVER BACK PANELS (DA-3717UK)

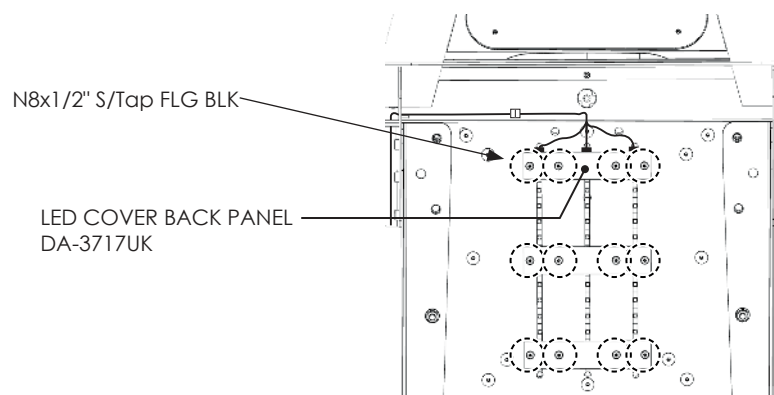

14-7 fig. 08

- 8 Once the covers have been removed, peel away the adhesive backed LED STRIPS.

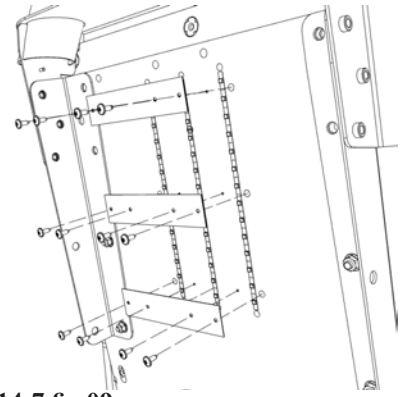

14-7 fig 09

- 9 Apply and secure the replacement ASSY SERIAL LED SEAT by following these instructions in reverse order.

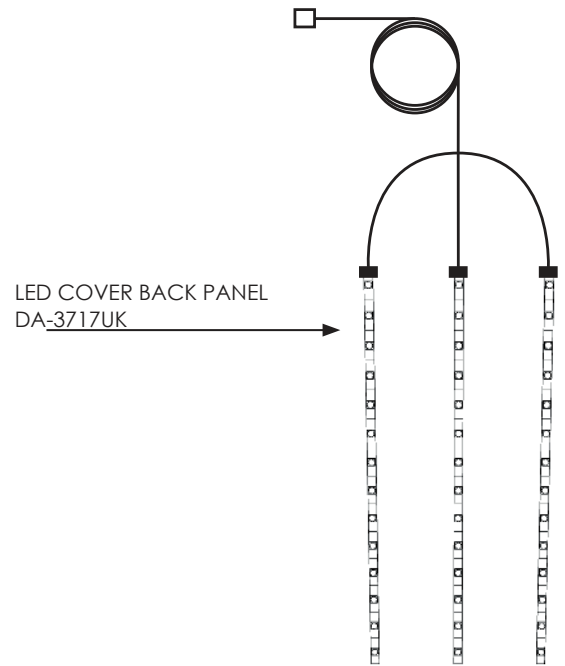

14-7 fig. 10

## 14-8 HEADREST LIGHTING

**1** Turn off the power.

**2** Locate the PANEL "A" FRAME (DA-3426UK)

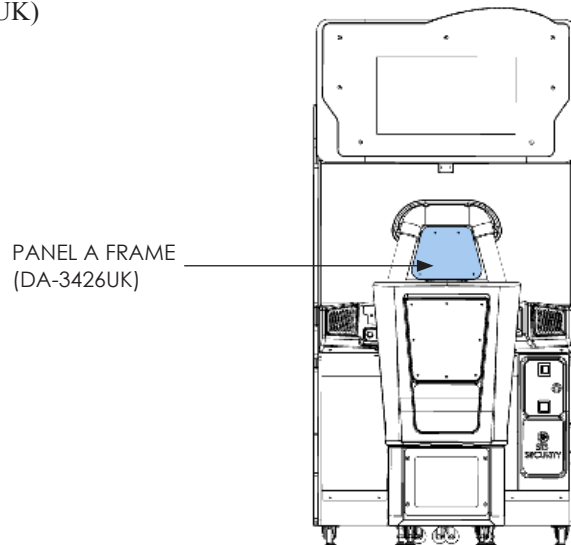

14-8 fig. 01

**3** Unsecure and remove the (4) M4x12 SKT BH BLK from the PANEL A FRAME .

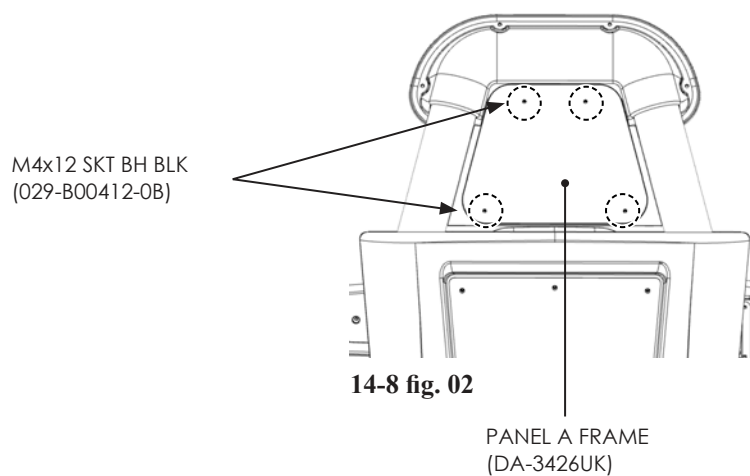

14-8 fig. 02

**4** Identify which of the LED strips require replacing. Unclip the header and peel away the adhesive LED strip from the back to the Seat Headrest. Replace the LED strip taking note on which end to place within the connector. Follow these instructions in reverse order to reassemble.

LED CONNECTOR  
BE-60001UK

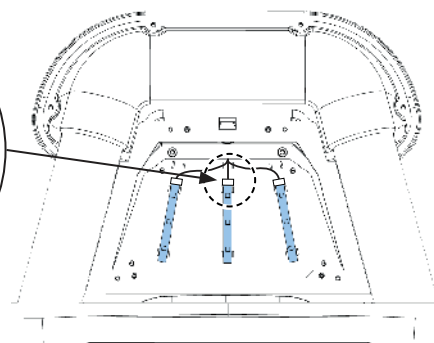
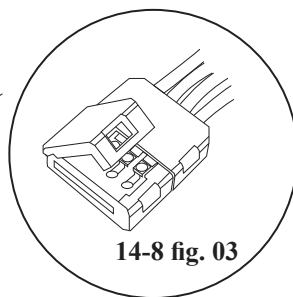
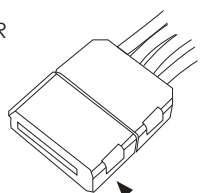

## 14-9 BILLBOARD LIGHTING

- 1 Turn off the power.
- 2 Using steps or ladders and another person, carefully remove the 7 fixings which secure the Billboard Header into position.

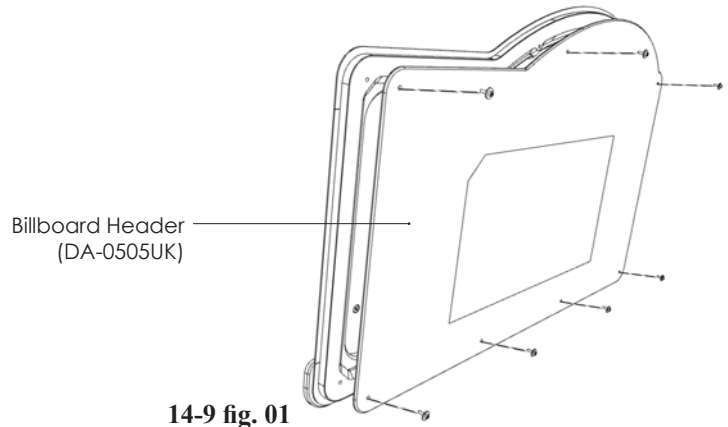

- 3 Locate the LED strip to be changed. There are two lengths within the BILLBOARD.

LED Strip Rigid 12v 700mm  
(390-3112-070WUK)

LED Strip Rigid 12v 400mm  
(390-3112-040WUK)

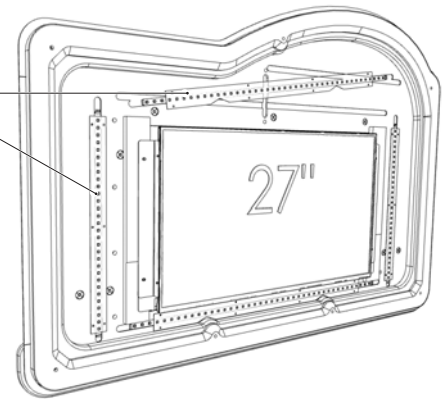

- 4 Locate the (8) fixings which secure the cover to the Back Panel. Remove fixings using a Phillip screwdriver. Remove the cover and disconnect the LED harness. Remove the LED Strip and replace.

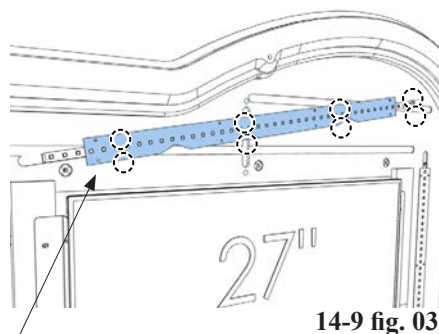

Remove the (8) screws positioned around the LED cover

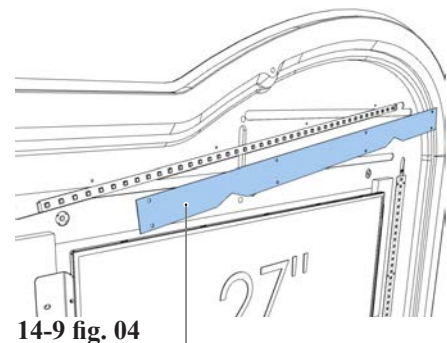

LED Light Cover Long BB  
(DA-0814UK)

## 15 PERIODIC INSPECTION

### WARNING

- Once a year, check to see if power cords are damaged, the plug is securely inserted, dust is accumulated between the socket outlet and the power plug, etc. Using the product with accumulated dust in the interior may cause fire or electric shock.
- Never use a water jet, etc. to clean the inside and outside of the cabinet. If wetness occurs for any reason, do not use the product until it has completely dried.
- Once a year, request the office shown on this manual or the dealer from whom the product was originally purchased to perform the internal cleaning. Using the product with accumulated dust in the interior may cause fire or other accidents. Note that you are liable for the cost of cleaning the interior parts.
- There is the danger of accidents involving electrical short circuits or fire caused by factors such as the deterioration of insulation in electrical and electronic equipment over time. Check that there are no abnormalities such as odors from burning.

### IMPORTANT

When the game is not in use, check the interior at regular intervals and make sure that nothing has been forgotten or placed on the seats.

### CAUTION

- Be careful not to get your fingers caught when opening/closing or attaching/removing doors, lids and other such parts.
- When working inside the cabinet, you could get caught on parts or scratch yourself on them. Check the inside of the cabinet and be aware of where the parts are before performing the work.

The items listed below require periodic checks and maintenance to guarantee the performance of this machine and to ensure safe operation.

Regularly clean all points of direct player contact such as the steering wheel and seat. Make regular inspections to ensure there is no damage to the surfaces and there are no foreign objects on the parts.

**TABLE 15 PERIODIC INSPECTION TABLE**

ITEMS	DESCRIPTION	PERIOD
CABINET	Confirm that adjusters contact floor	Daily
	Seat check, removal of forgotten / other items	Daily
LCD DISPLAY	Screen cleaning	Weekly
	Check screen adjustment	1 month
	Exchange of lamp unit	When message is displayed
CONTROL UNIT	Cleaning	As appropriate
	Potentiometer Inspection	1 month
	Greasing	3 months
SEAT MECH	Cleaning	As appropriate
	Check for loose fixings	3 months
	Greasing	3 months
ACCEL/BRAKE	Potentiometer Inspection	1 month
	Greasing	3 months
COIN SELECTOR	Inspection of coin switch	1 month
	Coin insertion test	1 month
	Coin Selector cleaning	3 months
GAME BOARD	Individual tests	1 month
	Check of settings	1 month
LAMPS AND LIGHTING	Inspection of lighting fixtures	As appropriate
ELECTRICAL/ELECTRONIC PARTS	Inspection	As appropriate
POWER CABLE	Inspection, Cleaning	1 year
CABINET INTERIOR	Cleaning	1 year
CABINET SURFACES	Cleaning	As appropriate

### **Cleaning the Cabinet Surfaces**

When the cabinet surfaces become dirty, remove stains with a soft cloth soaked in water or diluted (with water) chemical detergent and then wrung dry. To avoid damaging the finish, do not use such solvents as thinner, benzene, etc. (other than ethyl alcohol) or abrasives (bleaching agent and chemical dust-cloth).

Some general-purpose household, kitchen, and furniture cleaning products may contain strong solvents that degrade plastic parts, coatings, and print. Before using any cleaning product, read the product's cautionary notes carefully and test the product first on a small area that is not highly visible.

## 15-1 GREASING

### GREASING SEAT RAIL

Move the seat to the rear most position and apply grease to the portion shown in the figure once every 3 months by using a good quality white lithium grease. After greasing, move the seat a few times forward and backward so as to allow the grease to be applied all over uniformly. Remove any residue from the protect rubbers and surrounding area..

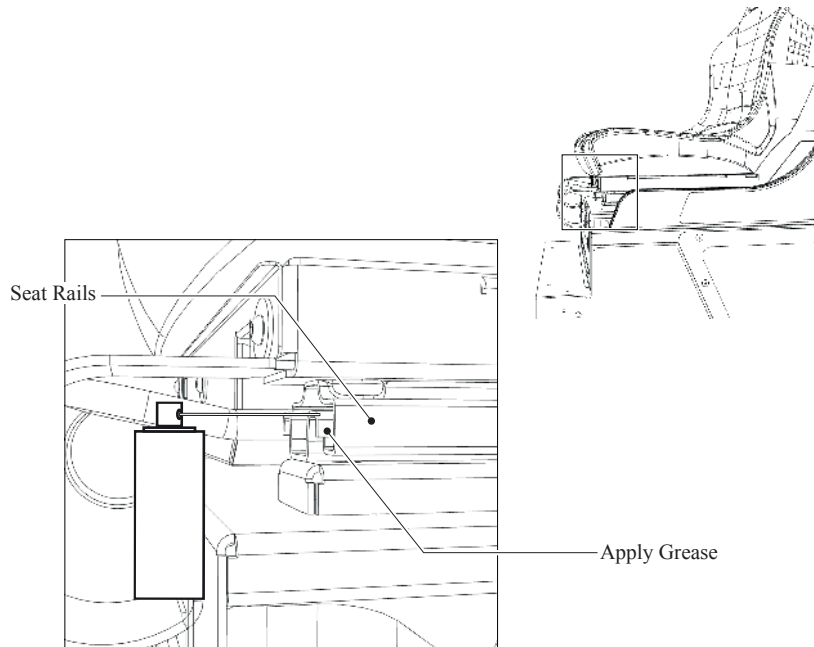

15-1 fig. 01

### GREASING BRAKE&ACCEL

Remove the (4) fixings which secure the front and rear covers. Apply the lubricant to the areas shown. Be sure to apply a good quality synthetic lubricant. Using a mineral based lubricant may cause damage to plastic parts. Do not apply lubricant to parts other than those mentioned. Doing so may cause premature deterioration.

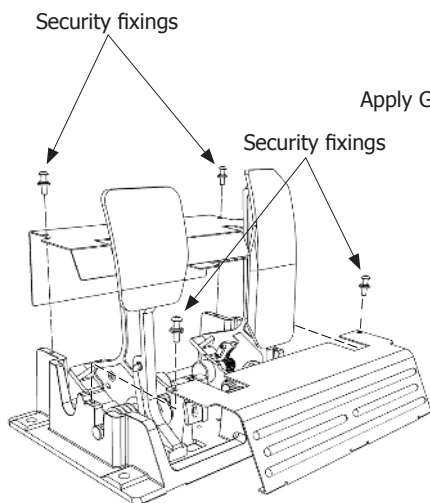

15-1 fig. 02

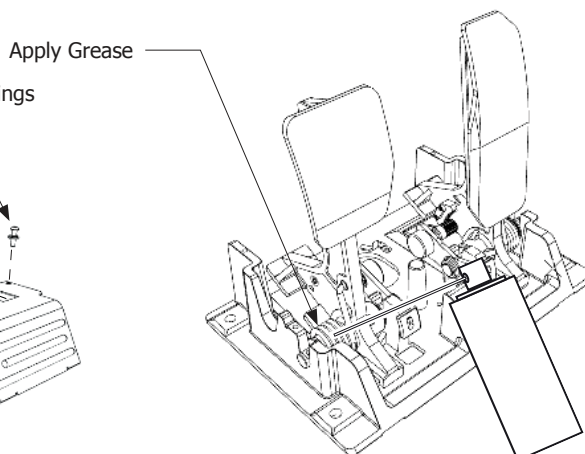

15-1 fig. 03

## 16 TROUBLESHOOTING & ERROR CODES

### WARNING

- If an error message is displayed, have the problem looked at by a store maintenance person or a technician. Unless the problem is addressed by someone with specialized knowledge or skills, there could be electrical shock, short circuits or fire. If there are no store maintenance people or technicians, cut off the power immediately and contact the office shown in this manual or the dealer from whom the product was originally purchased.
- If problems other than those covered in this manual arise, or if no improvements can be noted after measures given in this manual have been taken, do not take measures indiscriminately. Cut off the power immediately and contact the office shown in this manual or the dealer from whom the product was originally purchased. Indiscriminate countermeasures could lead to unforeseeable accidents. They could also result in permanent damages.
- When working with the product, be sure to turn the power off. Working with the power on may cause an electric shock or short circuit.
- Be careful not to damage the wires. Damaged wires may cause an electric shock, short circuit or present a risk of fire.
- After the cause of circuit protector activation has been removed, have the circuit protector re-engaged. If the unit is used continuously as is, there could be heat generation or fire, depending on the cause of the activation.

### CAUTION

- When removing and replacing parts, take due care not to trap or pinch your fingers.
- The Control Units contain gears, cams and other moving machine parts. Take due care not to trap or pinch your fingers.

**TABLE 16 TROUBLESHOOTING TABLE**

<b>PROBLEMS</b>	<b>CAUSE</b>	<b>COUNTERMEASURES</b>
When the main SW is turned ON, the machine is not activated.	The power is not ON.	Firmly insert the plug into the outlet.
	Incorrect power source/voltage.	Make sure that the power supply/voltage are correct.
	The Circuit Protector of the AC Unit functioned due to momentary overcurrent.	After eliminating the cause of overload, have the Circuit Protector of the AC Unit restored.
	The screen is not adjusted correctly.	Adjust the screen correctly.
No sound output.	The audio level has not been correctly set with the Hardware Volume Control.. .	Adjust the Hardware Volume Control until audio so the game can be heard.
	The volume levels within the Sound Settings in the Test Menu have not been set correctly.	Enter the Sound Settings menu from the Test Menu and check that all volume levels are set to the appropriate levels. Options are available within this menu to test the volume levels of each setting to make sure each are correct.
The Control Units (Steering wheel/Foot Pedals) do not operate correctly.	Due to external or environmental factors the targeting is off.	Perform calibration in TEST Mode.
	Volume damaged. (Potentiometer)	Exchange the volume.
The Foot pedals grind when operated or squeak.	Grease has deteriorated.	Apply grease to the designated grease areas.
The View buttons do not operating properly.	The Microswitch has damaged or malfunctioned.	Replace the Microswich.
	The connection to the Assy SW has broken.	Reconnect the connector
Control Unit does not respond.	The Control Unit motor is set not to move.	Alter the TEST Mode settings. (See 9.)
	Due to overload or other factors, an error has occurred with the motor, which has been sensed by the motor sensor and the motor has been stopped.	Remove the cause of the motor error.
	Motor damaged.	Exchange the motor.
The Control Unit makes a lot of noise when it vibrates.	Due to a problem with the vibration parts or wear over time, the internal parts worn.	Replace motor
The START switch does not operate	Faulty switch or bad connections	Check the connections on the rear of the switch. If connections are good, replace switch.

Linked cabinets will not sync together in the attract mode.	Network cables are not connected.	Reconnect the network cables to each cabinet.
	The cabinets are using security keys from different regions	Ensure each cabinet has the same region which is viewable on the System Information page. Cabinets will only link together from the same region.
	Network cables are faulty.	Replace the faulty network cables. Contact the company from whom the unit was purchased.
Cabinets are unable to start a Multi-player session together.	.Network cables are not connected.	Ensure network cables are properly connected to the cabinets.
	Cabinet ID's are not set up correctly.	Go into the Network Settings and ensure each cabinet has a different Cabinet ID. Confirm the settings and then the cabinets will reset with the new changes saved.
The Steering Wheel does not work correctly in the game.	The Steering Wheel has not been calibrated correctly.	Go into the Calibration Settings in the Test Menu and select Calibrate Steering.
The Pedals do not work correctly in the game. Vehicles move forward or backwards with no player input.	The Pedals have not been calibrated correctly.	Go into the Calibration Settings in the Test Menu and select Calibrate Brake and follow the on screen instructions. Once this has been done, select Calibrate Accelerator and follow the on screen instructions.
No audio can be heard in either the attract mode, or throughout the game.	The audio level has not been correctly set with the Hardware Volume Control..	Adjust the Hardware Volume Control until audio so the game can be heard.
	The volume levels within the Sound Settings in the Test Menu have not been set correctly.	Enter the Sound Settings menu from the Test Menu and check that all volume levels are set to the appropriate levels. Options are available within this menu to test the volume levels of each setting to make sure each are correct.
High Score Tables have not been cleared after attempting to clear them in the Bookkeeping menu.	The high scores have only been cleared on one cabinet when multiple cabinets are linked together.	When multiple cabinets are linked together, the high score tables will only be cleared if the process is done on all connected machines at the same time. Each cabinet must be in the Bookkeeping menu, and then Clear High Scores should be selected on each one and then confirmed. If any cabinets are left in the attract mode during this, the high score tables will not be cleared.

The Camera is not detected/ Operating	The camera is connected into the wrong USB port	Make sure the camera is connected into the USB3 port on the CPU. (The USB3 port is identified by its 'blue' colour). The camera will not operate in a standard USB port.
	Bad connections	Check that good connections are made in the camera USB cable and camera Ext. cable.
	Camera faulty	Replace camera.
An error message appears in the game that says: "IO BOARD NOT DETECTED".	The IO USB cable has become disconnected.	Reconnect the IO USB cable to the game board and perform a power cycle.
An error message appears in the game that says: "SECURITY KEY NOT DETECTED".	The security key has become disconnected.	Reconnect the security key to the game board and perform a power cycle.

**TABLE 16-1 ERROR MESSAGE TABLE**

The game is equipped with an integral fault monitoring system. Each time an identified fault is detected an error message is displayed on screen.

Below is a table showing possible common conditions. Please refer to them as a guide.

If the ERROR Code/Message displayed on screen is not supported by this manual then please contact your Sega Service Centre for diagnostics.

<b>ERROR MESSAGE</b>	<b>DESCRIPTION</b>	<b>TROUBLESHOOTING</b>
Error - No Security Key Found	The system was unable to detect a valid security key	Check USB Security Key
Error - Incorrect Key Inserted	The system found a security key but the configuration is not valid for this product	Check USB Security Key
Error - Security Failure	The system security has detected security issues with the installed software	Restore software from recovery USB stick
Error - I/O BD failure	The I/O Board was not detected on power up	Check I/O Board, Power supply and harnessing
Error - I/O BD disconnected	The IO Board was detected on power up, but has subsequently been disconnected from the software	Check I/O Board, Power supply and harnessing
Error - Update Copy Failed	The shell was unable to create main and backup copies of the game or during install or update	Check USB Install Media and re-apply update or re-install. If still failing restore software from USB Recovery stick
Error - Invalid Shell Update	The shell Update on the USB stick is not a valid update	Check USB Install Media and re-apply update
Error - Update Copy Fail	The shell was unable to create main and backup copies of the game or during install or update	Check USB Install Media and re-apply update or re-install. If still failing restore software from USB Recovery stick
Error - No Game Installed	The shell was unable to find a game on the disk to launch. A game needs to be installed.	Restore software from USB Recovery stick
Error - No Shell Installed	Launcher was unable to find a Shell on the disk to launch. A Shell needs to be installed.	Restore software from USB Recovery stick
Game Error	The game was unable to launch or has terminated abnormally. On reboot the game will be reinstalled from back up. If it fails again no further attempt to launch the game will be made on subsequent power cycles.	Restore software from USB Recovery stick

## 17 GAME BOARD

### WARNING

- When working with the product, be sure to turn the power off. Working with the power on may cause an electric shock or short circuit.
- Be careful not to damage the wires. Damaged wires may cause electric shock or short circuit or present a fire risk.
- Do not expose the game board, etc. without a good reason. Failure to observe this can cause electric shock hazard or malfunctioning.
- Do not use this product with connectors other than those that were connected and used with the game board at the time of shipping. Do not carelessly connect wires to connectors that were not used at the time of shipping, as this may cause overheating, smoke or fire damage.
- When returning the game board after making repairs or replacements, make sure that there are no errors in the connection of connectors. Erroneous connections can lead to electrical shock, short circuits or fires.
- When connecting a connector, check the direction carefully. Connectors must be connected in only one direction. If indiscriminate loads are applied in making connections, the connector or its terminal fixtures could be damaged, resulting in electrical shock, short circuits or fires.

### CAUTION

- In this product, setting changes are made during the test mode. The game board need not be operated. Use the game board, etc. as is with the same setting made at the time of shipment so as not to cause electric shock and malfunctioning.
- Static electricity from your body may damage some electronics devices on the IC board. Before handling the IC board, touch a grounded metallic surface so that the static electricity can be discharged.

### IMPORTANT

- When replacing the Game Bd. Remove all external USB devices before packaging it up and returning it to your Service Center. The replacement Game BD will not come with these devices fitted.
- When sending the Game Bd for repair, send it complete along with any external USB devices. Do not send the Game Bd with USB devices connected. Leaving the USB devices connected may cause damage.
- Make sure the Game BD is packaged in suitable box and protected using a cushioned filler. Sending the Game BD without suitable packaging may cause further damage which in turn will incur further repair costs.

## 17-1 HOW TO REMOVE GAME BOARD

The game board located at the rear of the cabinet behind the screen. Each car has it's own Game Board.

- 1 Turn the power off..
- 2 Remove the PANEL ACCESS GAME BD by unscrewing the (4) M4x25 SKT BH PAS Screws located at each corner,
- 3 Carefully disconnect all of the connectors connected to the Game Bd. Please refer to the next section in this manual, 16.2 Game Board Connectors.

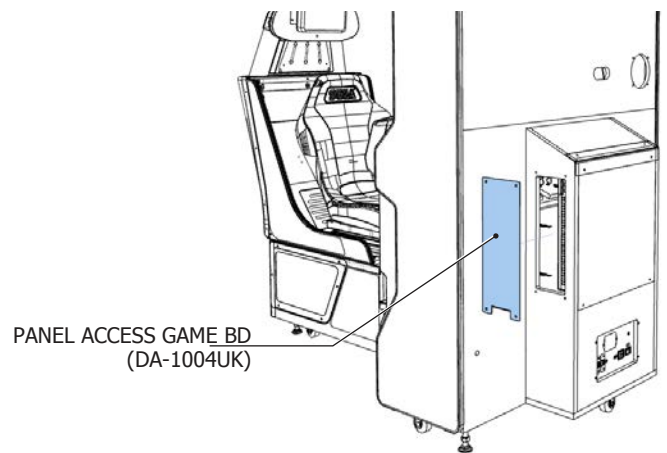

17-1 fig. 01

- 4 Locate and remove the (4) M4x25 SKT BH PAS fixings which secure the SASH BACK GAME BD to the Cabinet.

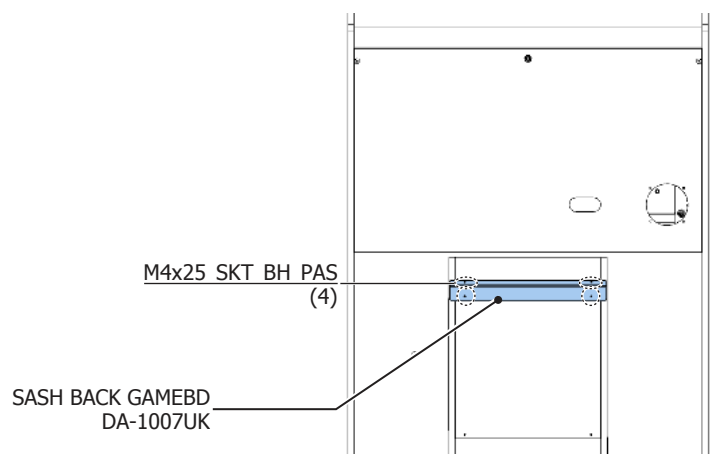

17-1 fig. 02

- 5** Locate and remove the (4) M4x25 SKT BH PAS fixings which secure the SASH BACK GAME BD to the Cabinet.

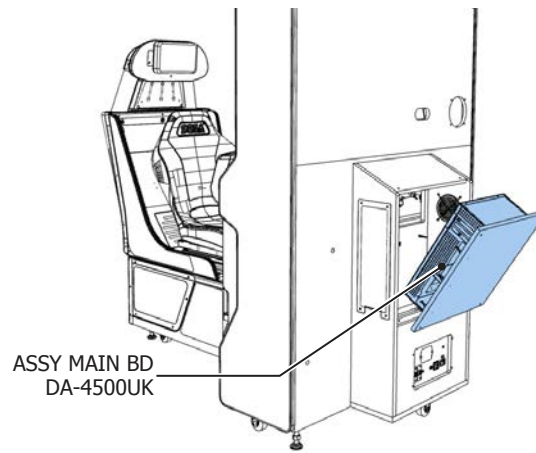

17-1 fig. 03

- 6** Locate and remove the (4) M4x25 SKT BH PAS fixings which secure the SASH BACK GAME BD to the Cabinet.

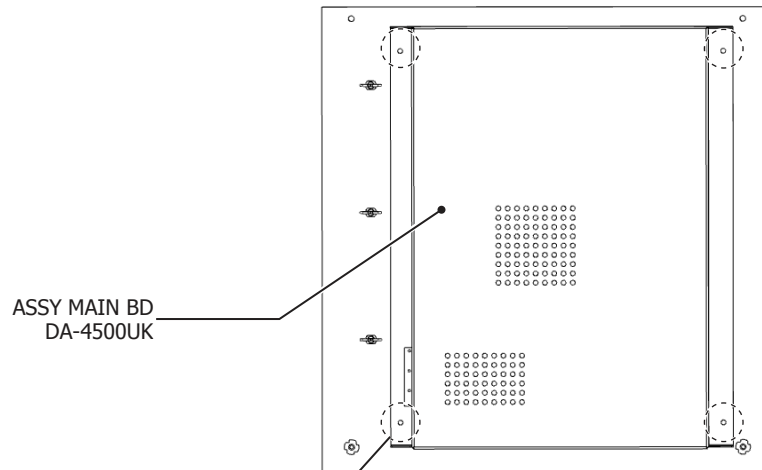

17-1 fir. 04

N8x1/2" S/TAP FLG BLK  
012-P00412-FB

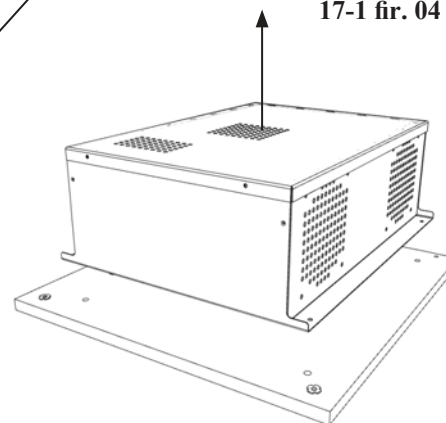

17-1 fig. 05

- 7** Replace the ASSY MAIN BD by following these instructions in reverse order.

## 16-2 GAME BOARD CONNECTORS

There are many connections to be made at the GAME BD. Although similar to a home personal computer in appearance, there are a few differences. Please be sure that each connection is made in the same position when disconnecting and reconnecting the Game Bd. Failing to make the same connections may result in malfunction.

### 17 GAME BOARD

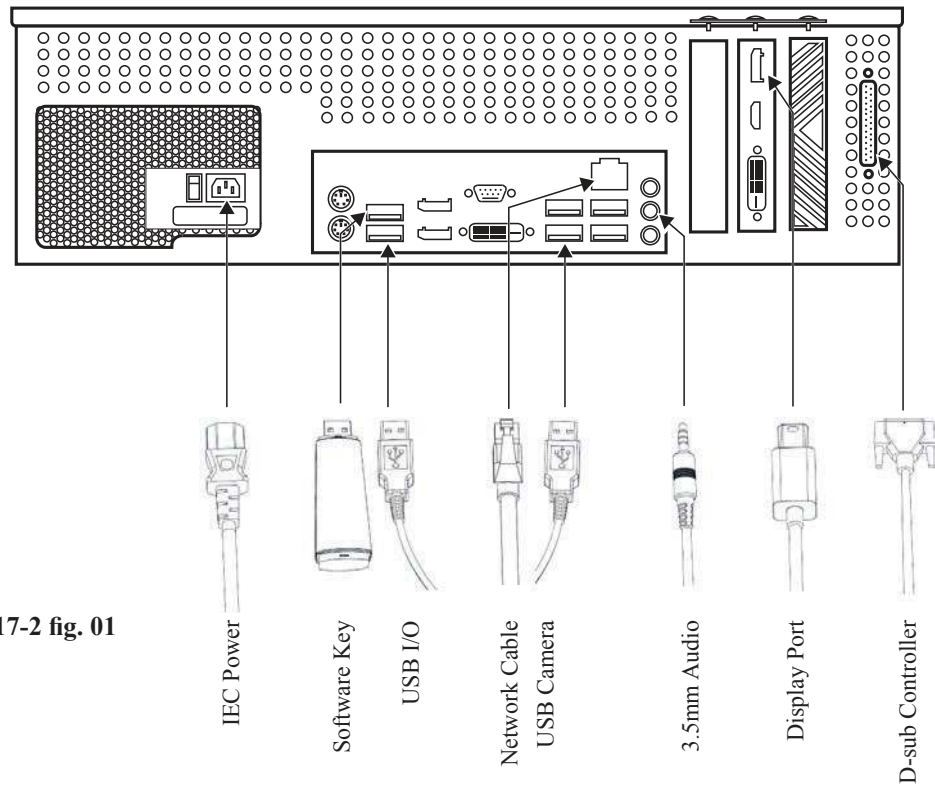

17-2 fig. 01

# 18 DESIGN RELATED PARTS

For the warning display stickers, refer to Section 1.

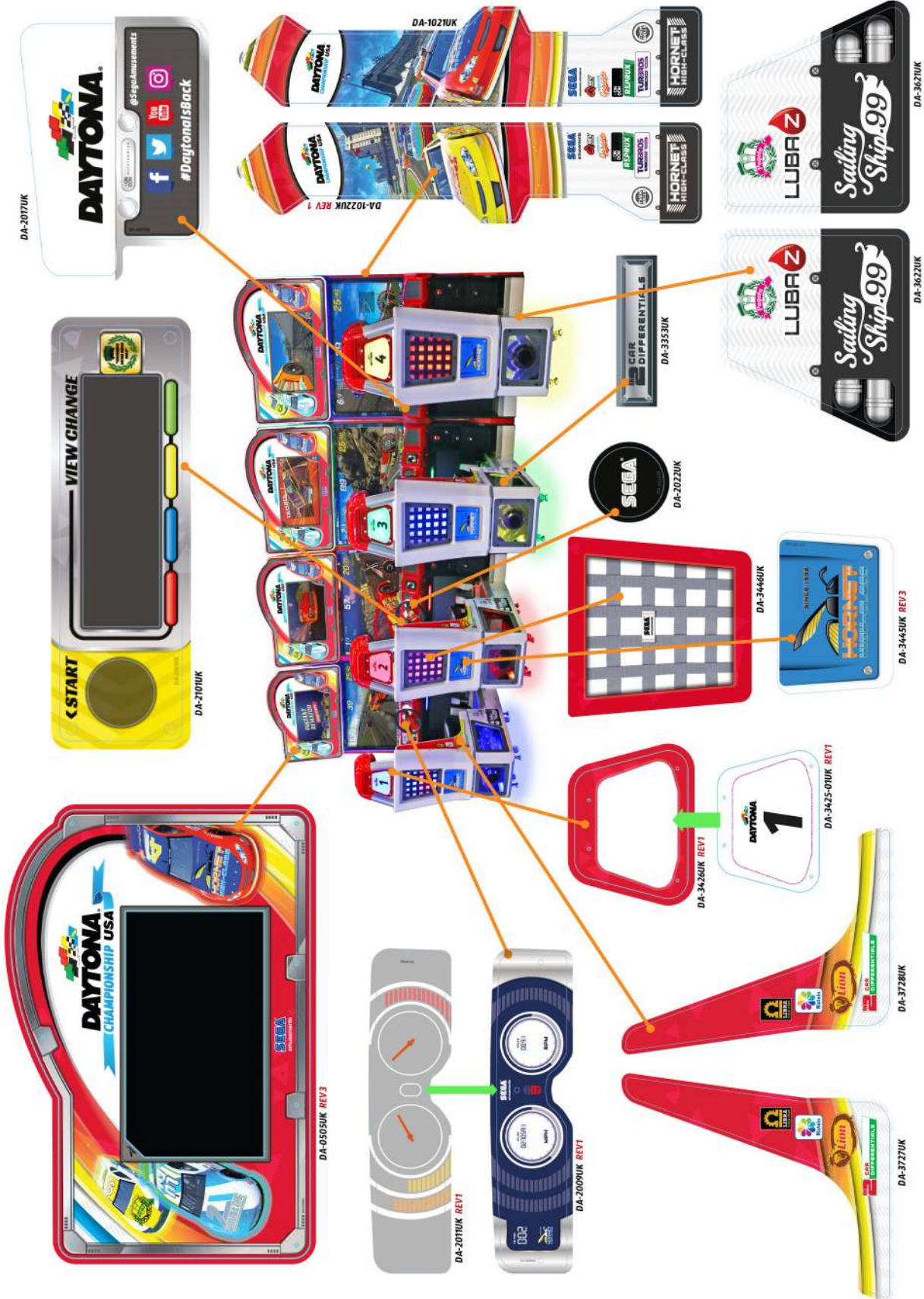

# 18 DESIGN RELATED PARTS

# 19 PARTS LIST

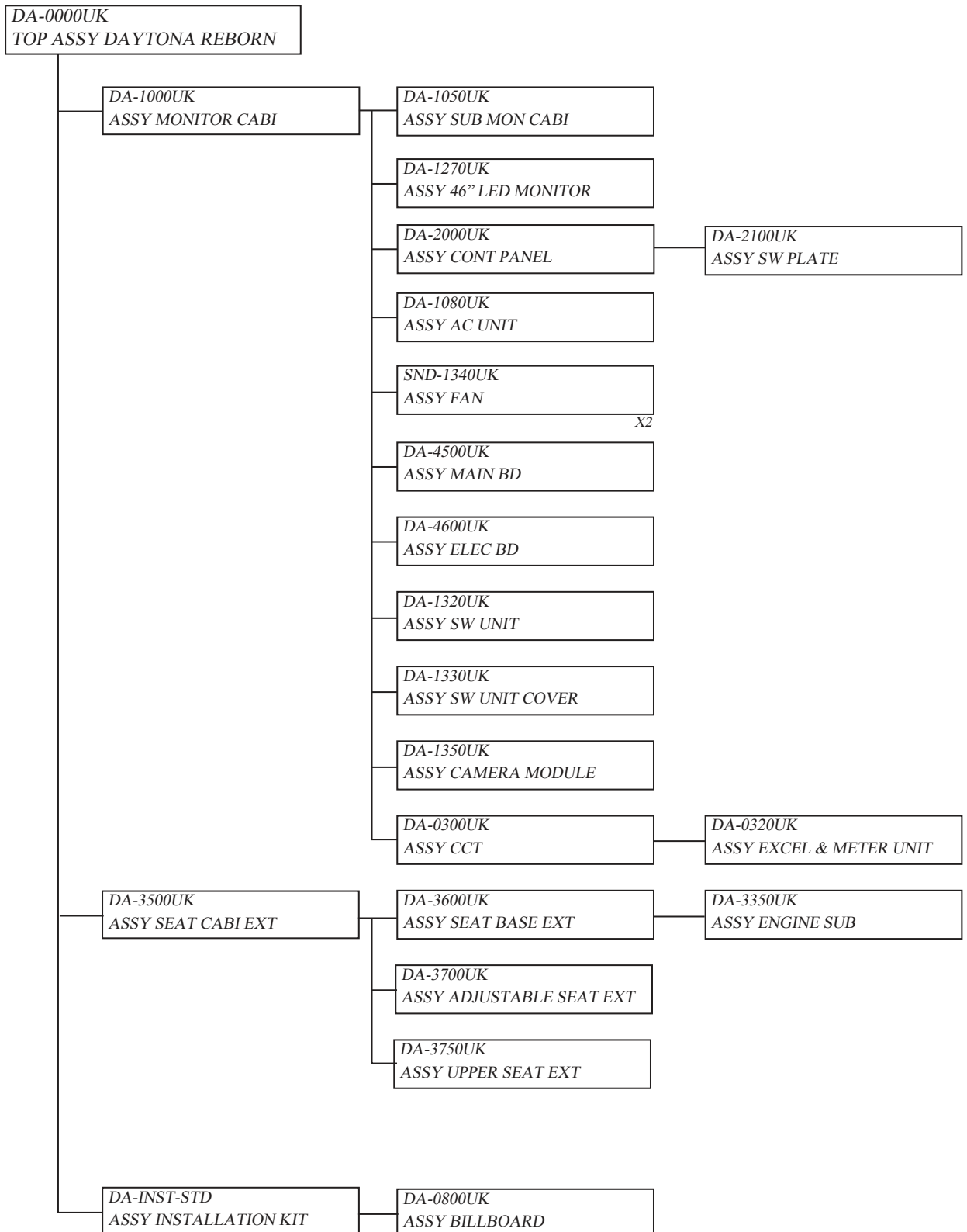

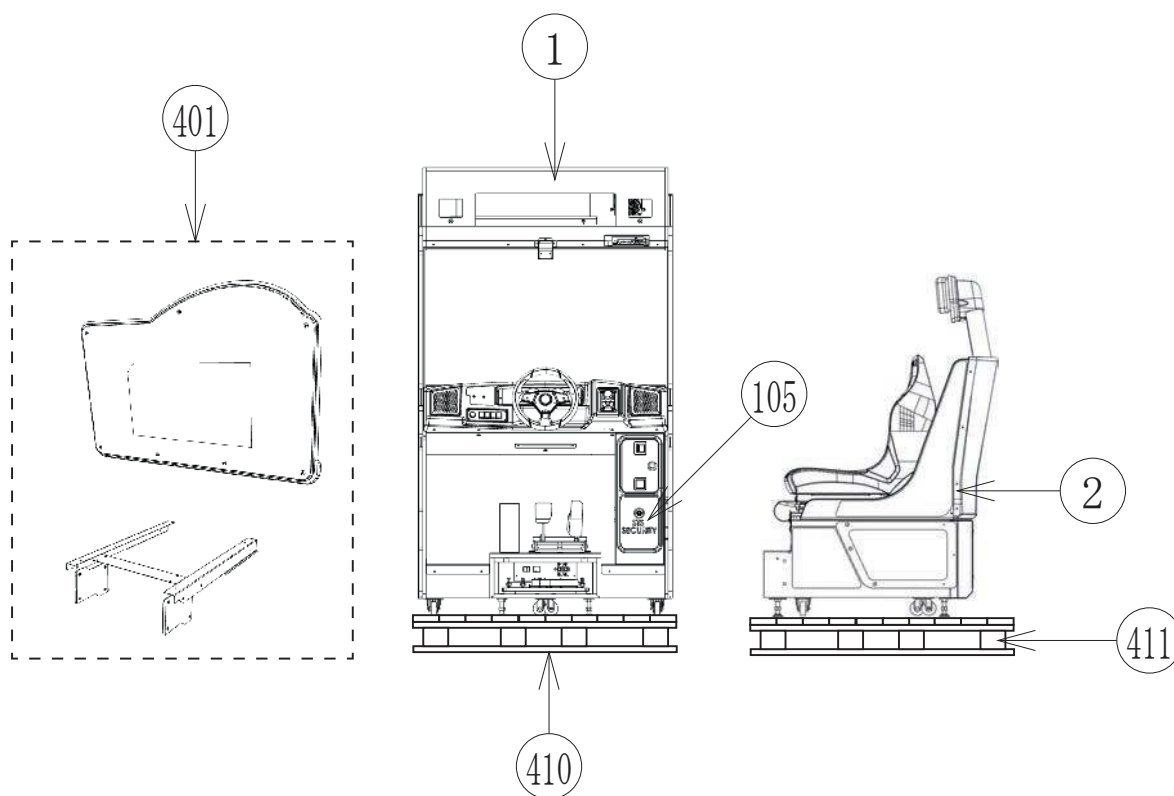

SEQ	PT NUMBER	DESCRIPTION	REFERENCE	QTY
*1	DA-1000UK	ASSY MONITOR CABI		1
*2	DA-3500UK	ASSY SEAT CABI EXT		1
*20	421-7988-91UK	STICKER SERIAL NUMBER UK		2
*21	440-WS0100UK	LABEL WARNING FORK HERE		4
*22	440-DS0010UK	LABEL DANGER HI VOLT	MON-1, GAMEBD-1, BACK DOORS-2	4
*23	LB1046	LABEL TESTED FOR ELEC. SAFETY		1
*24	LB1130	LABEL WEEE WHEELIE BIN		1
*26	440-CS0010UK	LABEL CAUTION GENERIC	MON-1, COIN DOOR-1	2
*105	220-5727-01B	DOOR CASH H.S. STS	(101)-1	1
**1	220-5575-280UK	LOCK(J9117) 28MM W/O CAM		1
*401	DA-INST-STD	ASSY INSTALLATION KIT DA STD		1
*410	PK0511	PALLET DA MONITOR DX		1
*411	PK0512	PALLET DA SEAT DX		1
or				
*411	PK0513	PALLET DA SEAT (DOUBLE) DX	2 SEATS	0.5
*412	440-PL0100UK	LABEL PACKING		1
*413	PK0468	SHRINK WRAP RD STD		2

② ASSY MONITOR CABI (DA-1000UK)

(D-1/2)

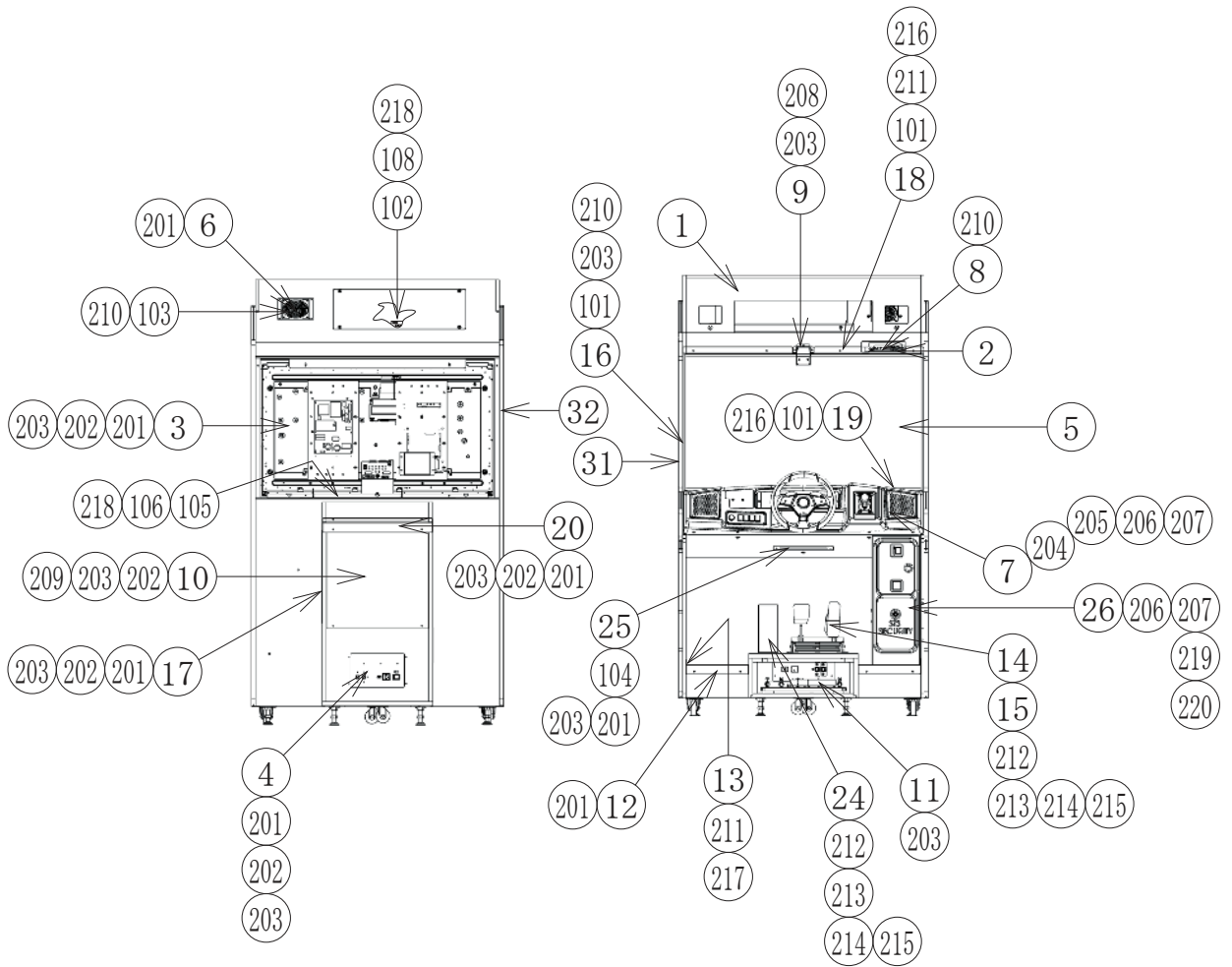

ITEM NO	PART NO	DESCRIPTION	REFERENCE	QTY
***1	DA-1050UK	ASSY SUB MONITOR CABI		1
***2	DA-1330UK	ASSY SWITCH UNIT COVER	LOCKED-IN	1
***3	DA-1270UK	ASSY 46 LED AUO MONITOR		1
***4	DA-1080UK	AC UNIT		1
***5	DA-1279UK	GLASS LED 46 AUO SCREEN PROTECT	SLOT-IN	1
or	DA-1269UK	GLASS LED 42 AUO SCREEN PROTECT		1
or	DA-1289UK	GLASS LED 43 MAK SCREEN PROTECT		1
or	DA-1299UK	GLASS LED 47 MAK SCREEN PROTECT		1
***6	SND-1340UK	ASSY FAN		2
***7	DA-2000UK	ASSY CONTROL PANEL		1
***8	DA-1320UK	ASSY SW UNIT		1
***9	DA-1350UK	ASSY CAMERA MODULE		1
***10	DA-4500UK	ASSY MAIN BD		1
***11	DA-4600UK	ASSY ELEC BD		1
***12	DA-1001UK	SASH FRONT STEP		2
***13	DA-1002UK	SASH CHEEK STEP		2
***14	SPG-2200-01-CN	ASSY ACCEL & BRAKE CHINA		1
***15	SPG-2224UK	PEDAL GASKET	(14)-1	1

② ASSY MONITOR CABI (DA-1000UK)

(D-2/2)

***16	DA-1003UK	BRKT GLASS RETAIN		2
***17	DA-1004UK	PANEL ACCESS GAMEBD		1
***18	DA-1005UK	SASH GLASS RETAIN TOP		1
***19	DA-1006UK	BRKT CNTRL PNL TOP		1
***20	DA-1007UK	SASH BACK GAMEBD		1
***21	DA-1008UK	PLATE BLANKING CCT		1
***24	TFF-1202UK	FOOTREST BASE		1
***25	RD-1218UK	COVER FOOTWELL LIGHT		1
***26	DA-0300UK	ASSY COIN CHUTE TOWER		1
***31	DA-1021UK	STICKER MONITOR CABI LH SIDE		1
***32	DA-1022UK	STICKER MONITOR CABI RH SIDE		1
***101	OS1230	FOAM STRIP 2mm X 10mm	(16)-0.63,(18)-1.07,(19)-1.07	3.4
***102	610-1002-02UK	RASPBERRY Pi 3 MODEL B		1
***103	FN1012	FAN GUARD METAL 120MM (FG-12)		2
***104	390-2012-020RGB	LED FLX STRIP RGB 12V 20CM	FOOTWELL	1
***105	601-SF110D-05UK	SWITCH 5 PORT SF110D-05		1
***106	280-A01264-WX	ROUTER TWIST D12 SO6.4 WOOD X	(105)-4	14
***107	280-A02064-WX	ROUTER TWIST D20 SO6.4 WOOD X		9
***108	280-L00605-OS	STANDOFF 6.35OD 3.56ID 4.76L	(102)-4	4
***201	029-B00425	M4X25 SKT BH PAS	(3)-5,(4)-4,(6)-4,(12)-2,(17)-4,(20)-4,(25)-2	31
***202	060-S00400	M4 WSHR SPR PAS	(3)-5,(4)-4,(10)-2,(17)-4,(20)-4	19
***203	068-441616	M4 WSHR 16OD FLT PAS	(3)-5,(4)-4,(9)-3,(10)-2,(11)-2,(16)-3,(17)-4,(20)-4,(25)-2	32
***204	020-F00830-0B	M8X30 SKT CSK BLK	(7)-8	8
***205	029-B00825-0B	M8X25 SKT BH BLK	(7)-3	3
***206	060-S00800-0B	M8 WSHR SPR BLK	(7)-3,(26)-3	6
***207	068-852216-0B	M8 WSHR 22OD FLT BLK	(7)-3,(26)-3	6
***208	050-U00400	M4 NUT NYLOK PAS	(9)-3	3
***209	000-P00450	M4X50 MSCR PAN PAS	(10)-2,(11)-2	4
***210	029-B00412-0B	M4X12 SKT BH BLK	(8)-3,(16)-3,(21)-2,(103)-4	19
***211	068-441616-0B	M4 WSHR 16OD FLT BLK	(13)-2,(18)-4,(21)-2	10
***212	029-B00840	M8X40 SKT BH PAS	(14)-4,(24)-4	8
***213	060-S00800	M8 WSHR SPR PAS	(14)-4,(24)-4	8
***214	068-852216	M8 WSHR 22OD FLT PAS	(14)-4,(24)-4	8
***215	029-B00425-0B	M4X25 SKT BH BLK	(18)-4	4
***216	050-F00800	M8 NUT FLG SER PAS	(19)-4	4
***217	029-B00416-0B	M4X16 SKT BH BLK	(13)-2	4
***218	012-P00312	N4X1/2" S/TAP PAN PAS	(102)-4,(105)-2	6
***219	029-B00840-0B	M8X40 SKT BH BLK	(26)-5	5
***220	050-U00800	M8 NUT NYLOK PAS	(26)-2 (BACK FIXINGS)	2
***301	DA-60012UK	WH PEDALS		1
***302	DA-60016UK	WH AC TO MONITOR		1
***303	DA-60025UK	WH CTRL TO BILLBOARD		1
***304	DA-60026UK	WH CTRL TO BASE		1
***305	BE-6001UK	ASSY LED CLIP		1
***306	DA-60022UK	WH VIDEO BILLBOARD		1
***307	600-7013-100UK	DVI-HDMI 100CM		1
***308	600-7269-0200UK	ASSY LAN CABLE 200CM		3
***309	600-7269-100UK	ASSY LAN CABLE 100CM		1
***310	600-7158-0150UK	CA AUDIO RCA 150CM		1
***311	600-7015-200UK	USB EXTN A-A		1
***312	600-7141-100UK	CABLE JVS TYPE A-B 100cm		1
***313	600-7017-200UK	CA DISPLAY PORT MALE-MALE		1

### ③ ASSY 46" LED AUO MONITOR

(D-1/1)

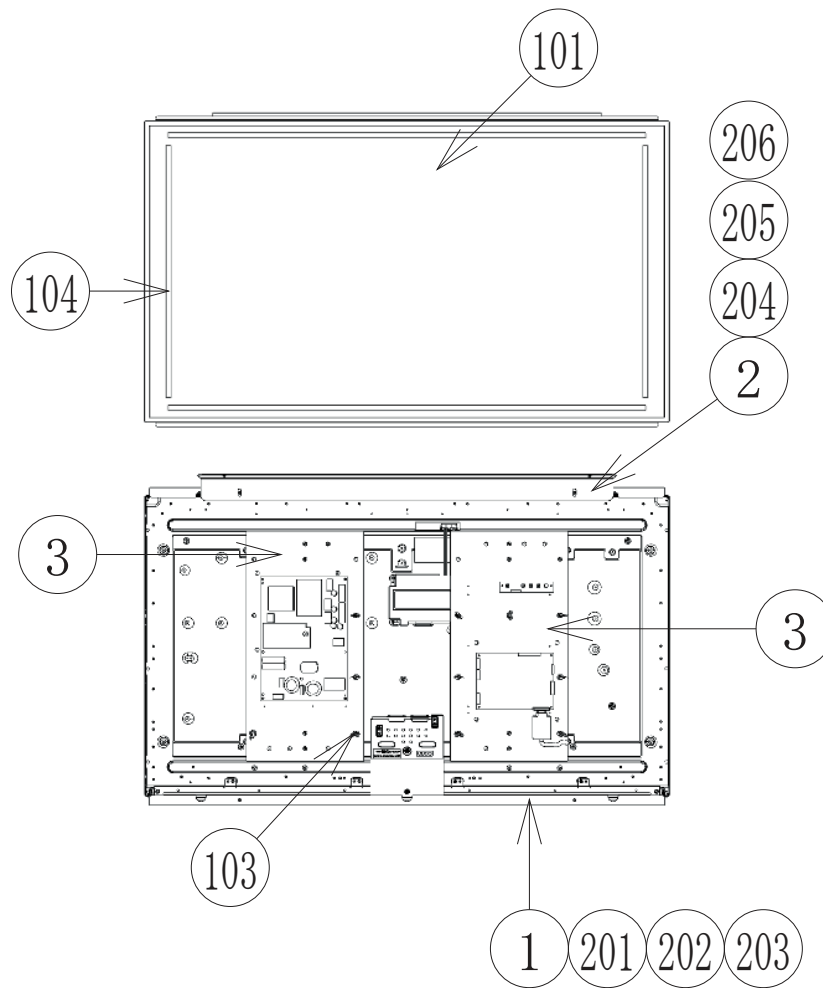

ITEM NO	PART NO	DESCRIPTION	REFERENCE	QTY
****1	DA-1271UK	BRKT LCD SUPPORT BASE		2
****2	DA-1272UK	BRKT LCD SUPPORT TOP		1
****3	TRF-1210UK	PNL PRISMA BD DMODUL MNT 55		2
***21	440-WS0002UK	LABEL WARNING HI VOLT		1
***22	440-DS0010UK	LABEL DANGER HI VOLT		2
****101	200-6046-AUO	46" LCD AUO P460HVN02.1		1
****102	OS1247	ALUMINIUM STICKY CLIP ASK-3		2
****103	280-A01264-WX	ROUTER TWIST D12 SO6.4 WOOD XL		5
****104	OS1230	FOAM STRIP 2mm X 10mm	AROUND SCREEN	3.3
****105	280-L00811-OS	STANDOFF 7.94OD 3.56ID 11.11L	(LED PCBS)-10	10
****201	029-B00305	M3X5 SKT BH PAS	(1)-4	8
****202	060-S00300-0B	M3 WSHR SPR BLK	(1)-4	8
****203	060-F00300-0B	M3 WSHR FORM A FLT BLK	(1)-4	8
****204	029-B00412	M4X12 SKT BH PAS	(2)-2	2
****205	060-S00400	M4 WSHR SPR PAS	(2)-2	2
****206	068-441616	M4 WSHR 16OD FLT PAS	(2)-2	2

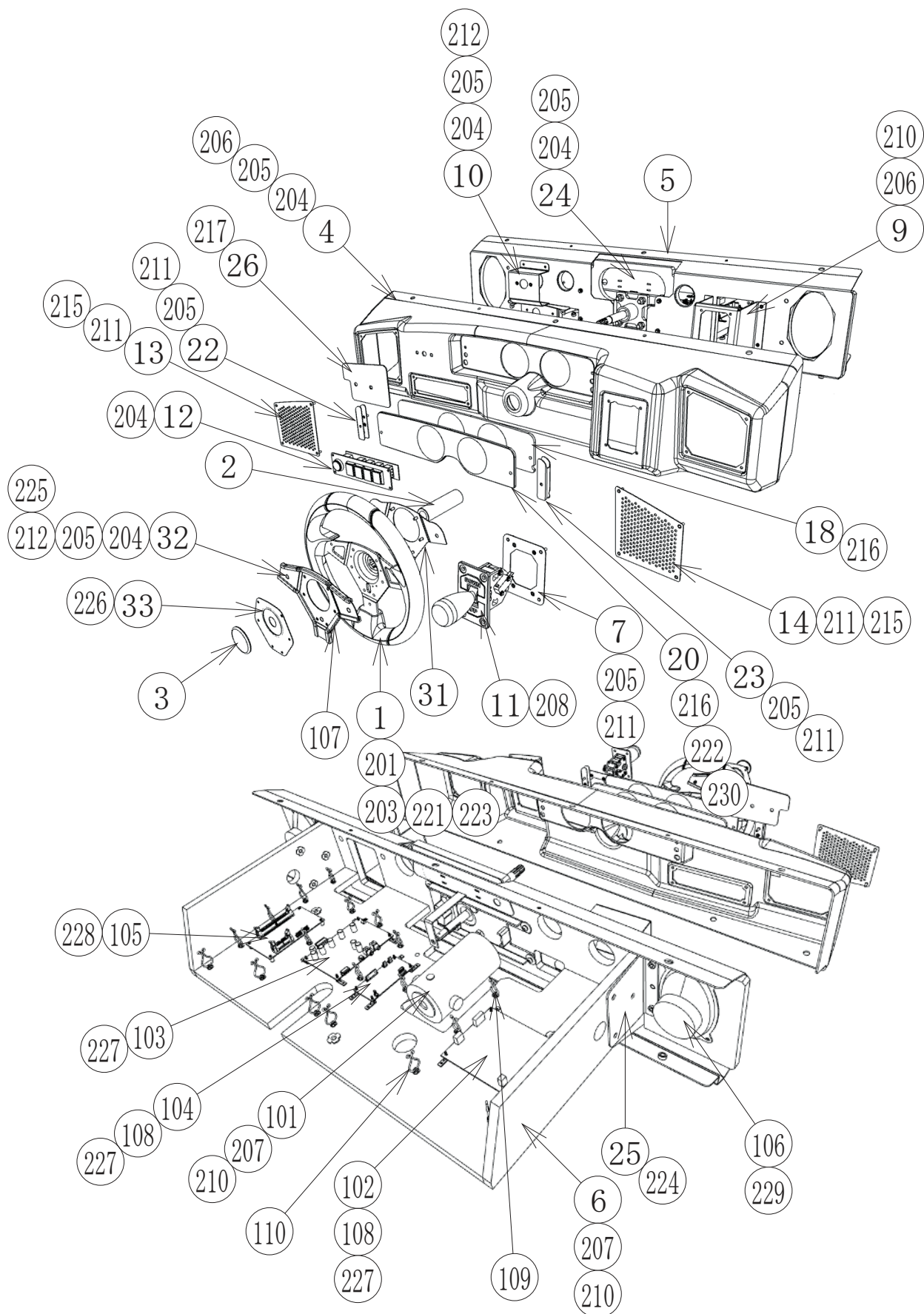

# 4 ASSY CONTROL PANEL (DA-2000UK)

(D-2/3)

ITEM NO	PART NO	DESCRIPTION	REFERENCE	QTY
****1	RNE-2001	STEERING WHEEL		1
****2	RD-2009UK	HANDLE COLLAR	(FIT OVER SHAFT) check length	1
****3	DA-2022-BUK	STEERING EMBLEM	(STUCK ON) local?	1
****4	DA-2001-01UK	CONTROL PANEL COVER		1
****5	DA-2002UK	CTRL PNL SUPP BRKT		1
****6	DA-2003UK	BASE CTRL PNL		1
****7	DA-2005-01UK	SHIFT COVER U/D SOJ		1
****9	DA-2004UK	SHIFT BRACKET		1
****10	DA-2006UK	BRKT CONTROL BUTTON		1
****11	610-0408-01	UP/DOWN SHIFTER AL YL	are we using?	1
****12	DA-2100UK	ASSY SW PLATE		1
****13	DA-2007UK	SPEAKER GRILLE L	(1)-1	1
****14	DA-2008UK	SPEAKER GRILLE R	multi? was 4RD-0012UK on proto	1
****18	DA-2009UK	PLATE DIALS INNER		1
****20	DA-2011UK	PLATE DIALS OUTER		1
****22	DA-2013UK	BRKT DIALS SECURE L		1
****23	DA-2014UK	BRKT DIALS SECURE R		1
****24	DA-2015UK	PLATE DIALS BACK LIT		1
****26	DA-2017UK	PLATE COVER CARD READER		1
****31	RND-0222	PLATE REAR RNE HOOP		1
****32	RND-0223	PLATE FRONT RNE HOOP		1
****33	RND-0224	PLATE FRONT UPPER CAP RNE HOOP		1
****101	RD-2500UK	MECHA 50-0102-07PT W/SEGA SHAFT		1
****102	FR-838-001UK	MOTOR CONTROL PCB 50-2000-03		1
****103	838-0026UK	SOUND AMP ANALOG IN		1
****104	838-0031UK	LED DRIVER ATMEGA 328		1
****105	838-0005-UK	I/O BOARD SAE		1
****106	130-04030-E	SPKR ELIP 4OHM 30W VIS DX4x6P		2
****107	OS1254	EDGING C PROFILE PVC TRIM	(1)-0.5m	0.5
****108	OS1011	PCB FEET RICHCO LCBS-L-5-01	(102)-4,(103)-4,(104)-4	12
****109	280-A01264-WX	ROUTER TWIST D12 SO6.4 WOOD X		13
****110	280-A02064-WX	ROUTER TWIST D20 SO6.4 WOOD X		8
****201	020-000820	M8X20 BLT PAS	(1)-1 (USE ANAEROBIC RE-TAINER)	1
****203	060-S00800	M8 WSHR SPR PAS	(1)-1	1
****204	029-B00412	M4X12 SKT BH PAS	(4)-2,(10)-4,(12)-4,(24)-2	12
****205	068-441616	M4 WSHR 16OD FLT PAS	(4)-2,(7)-4,(10)-4,(22)-1,(23)-1,(24)-2,(32)-3	17
****206	029-B00612	M6X12 SKT BH PAS	(4)-4,(9)-4	8
****207	029-B00630-0B	M6X30 SKT BH BLK	(6)-4,(101)-4	8
****208	029-B00512-0B	M5X12 SKT BH BLK	(11)-4	4
****210	060-S00600	M6 WSHR SPR PAS	(6)-4,(9)-4,(25)-3,(101)-4	18
****211	050-U00400	M4 NUT NYLOK PAS	(7)-4,(13)-4,(14)-4,(22)-1,(23)-1	14
****212	060-S00400	M4 WSHR SPR PAS	(10)-4,(32)-3	7
****215	060-F00400-0B	M4 WSHR FORM A FLT BLK	(13)-4,(14)-4	8
****216	029-B00416-0B	M4X16 SKT BH BLK	(18-20)-2	2
****217	029-B00616	M6X16 SKT BH PAS	(26)-2	2
****218	068-652016	M6 WSHR 20OD FLT PAS	(4)-4,(6)-4,(25)-3,(101)-4	18
****221	060-F01600	M16 WSHR FORM A FLT PAS	under (223)	2

# ④ ASSY CONTROL PANEL (DA-2000UK)

(D-3/3)

ITEM NO	PART NO	DESCRIPTION	REFERENCE	QTY
****222	029-B00425-0B	M4X25 SKT BH BLK	(20)-1	1
****223	068-852515-OB	M8 WSHR 25OD FLT BNP	(1)-3 SPG-2039 REPLACEMENT	3
****224	029-B00625	M6X25 SKT BH PAS	(25)-3	6
****225	029-B00408	M4X8 SKT BH PAS	(32)-3	3
****226	020-B00308-0B	M3X8 SKT BH BLK	(33)-6	6
****227	012-P03506-F	N6X1/4" S/TAP FLG PAS	(102)-4,(103)-4,(104)-4	12
****228	012-P00325	N4X1" S/TAP PAN PAS	(105)-4	4
****229	012-P03512-F	N6X1/2" S/TAP FLG PAS	(106)-4	8
****230	050-F00400	M4 NUT FLG SER PAS	(20)-1	1
****301	DA-60005UK	WH MOTOR CONTROL		1
****302	DA-60006UK	WH PARALLEL A		1
****303	DA-60008UK	WH SPEAKERS		1
****304	DA-60009UK	WH I/O		1
****305	DA-6004UK	ASSY DIALS LED		1

⑤ ASSY AC UNIT (DA1080UK)

(D-1/1)

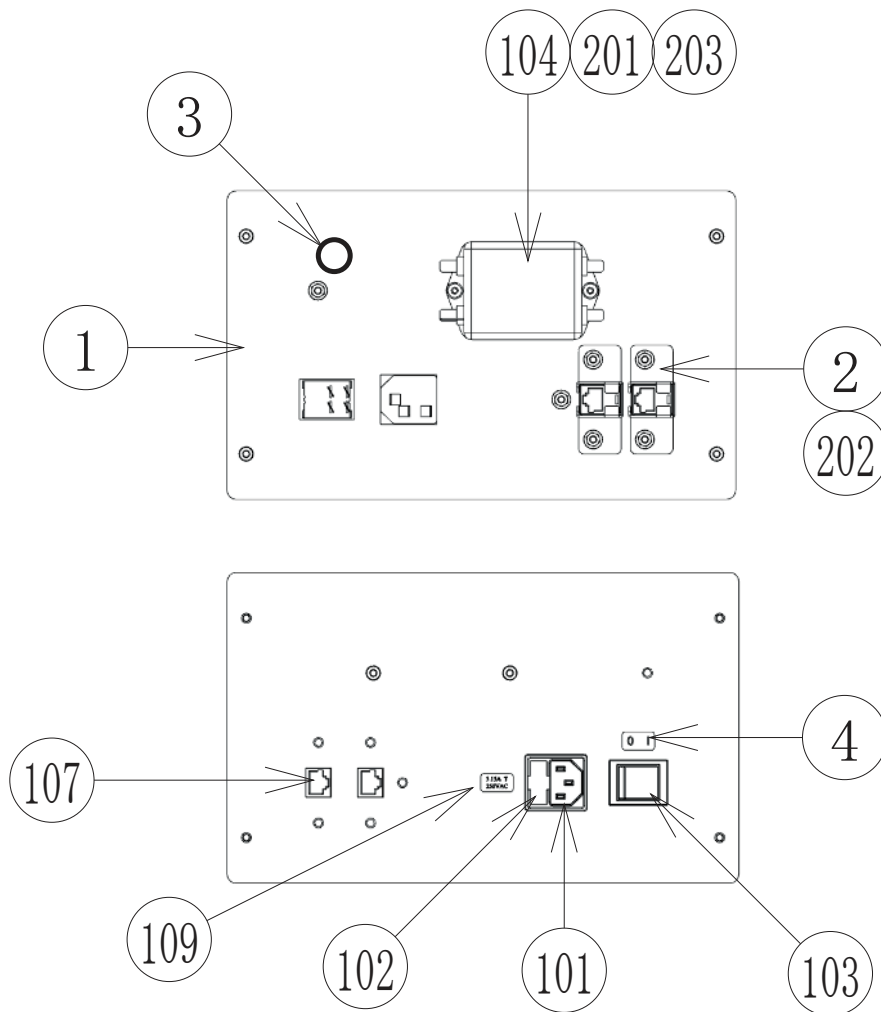

ITEM NO	PART NO	DESCRIPTION	REFERENCE	QTY
***1	DA-1081UK	PLATE AC		1
***2	TFF-0402UK	CONN COVER		2
***3	LB1096	STICKER PROTECTIVE EARTH		1
***4	LB1131	LABEL ON / OFF		1
***101	EP1302	EUROSOCKET FUSED 10A 250VAC	CLIP-IN	1
***102	514-5078-3150	FUSE 3.15 X 20 CERAMIC SB 3150mA	CLIP-IN	2
***103	SW1109	SWITCH ROCKER 250V AC	CLIP-IN	1
***104	EP1419	FILTER SCHAFFNER 2030-16-06		1
***107	EP1391	COUPLER INLINE LAN RJ45		2
***108	310-5029-D508	HEAT SHRINK SLEEVING 50.8DIA	(101)-4,(103)-6	10
***109	LB1126-3150-250	FUSE LABEL 3.15A 250V		1
***201	029-B00408	M4X8 SKT BH PAS	(104)-2	2
***202	050-F00400	M4 NUT FLG SER PAS	(2)-4, 2-EARTH	6
***203	060-S00400	M4 WSHR SPR PAS		2
***301	DA-60001UK	WH AC IN		1

⑥ ASSY FAN (SND-1340UK)

(D-1/1)

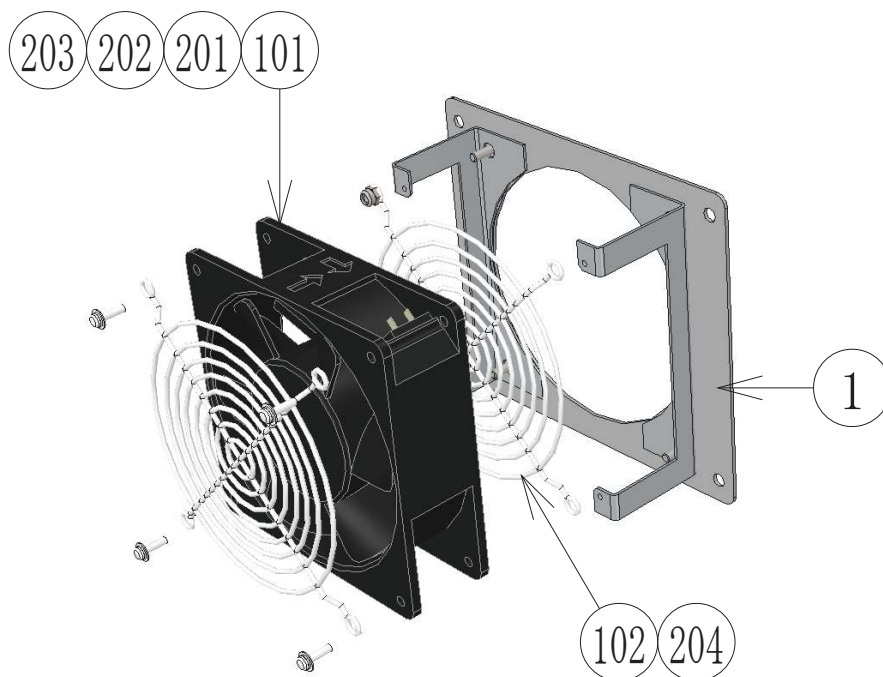

ITEM NO	PART NO	DESCRIPTION	REFERENCE	QTY
***1	SND-1341UK	BRKT FAN MTG		1
***101	260-0012-01UK	FAN DC 12V RoHS		1
***102	FN1012	FAN GUARD METAL 120MM (FG-12)		2
***201	020-B00316-0B	M3X16 SKT BH BLK	(101)-4	3
***202	060-S00300-0B	M3 WSHR SPR BLK	(101)-4	3
***203	060-F00300-0B	M3 WSHR FORM A FLT BLK	(101)-4	3
***204	050-U00400	M4 NUT NYLOK PAS	(102)-4	4
***205	OS1098	CRIMP BELL END SMALL		2
***301	DB-60030UK	WH LED WHT		1

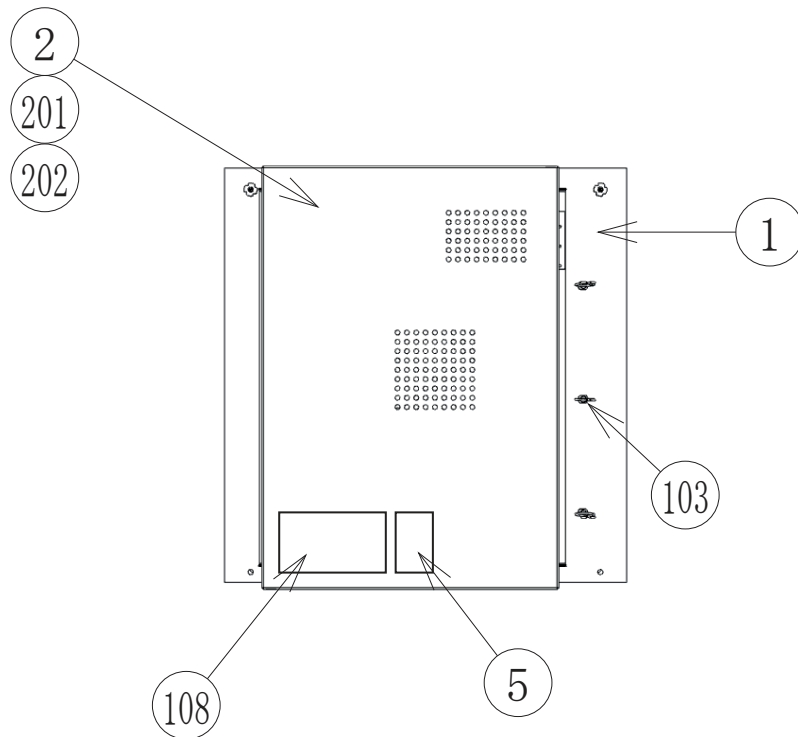

ITEM NO	PART NO	DESCRIPTION	REFERENCE	QTY
****1	DA-4501UK	WOODEN BASE MAIN BD		1
****2	610-0010UK	ASSY MAIN BOARD		1
****5	LB1111	STICKER PLEASE RECYCLE		1
****102				5
****103	280-A02064-WX	ROUTER TWIST D20 SO6.4 WOOD X		3
****108	LB1101	STICKER WARNING BATTERY	GAME BD	1
****201	029-B00412	M4X12 SKT BH PAS	(2)-4	4
****202	068-441616	M4 WSHR 16OD FLT PAS	(2)-4	4

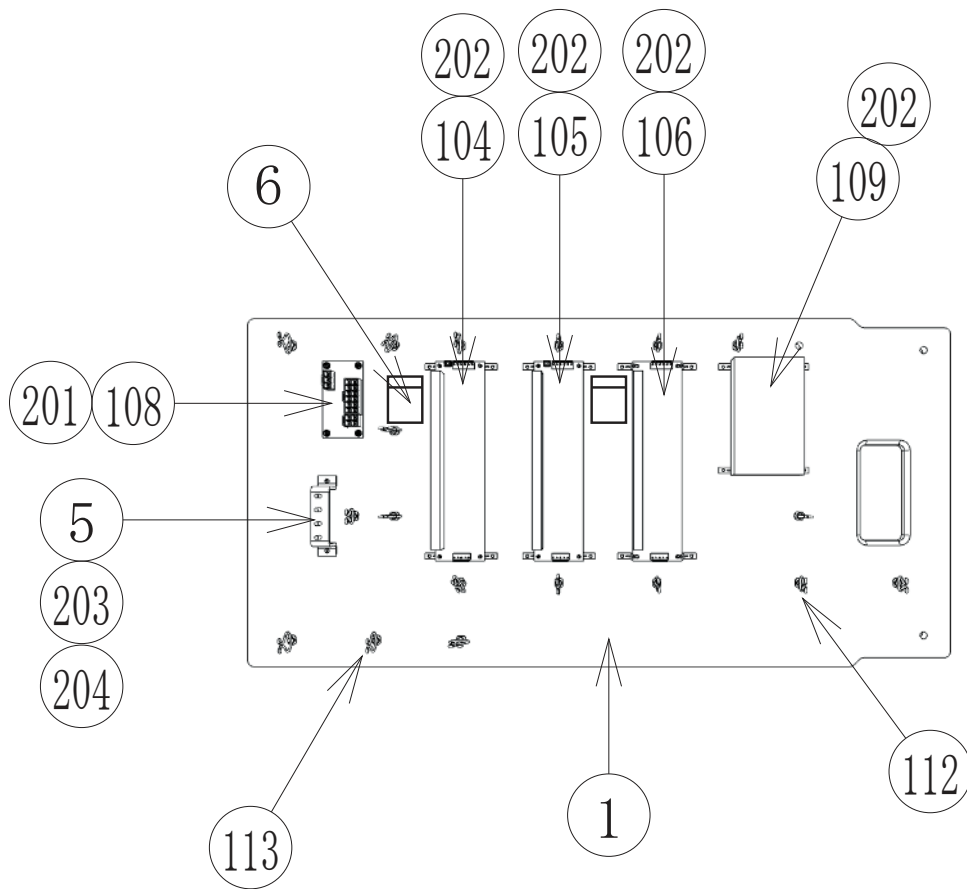

ITEM NO	PART NO	DESCRIPTION	REFERENCE	QTY
****1	DA-4601UK	WOODEN BASE ELEC BD		1
****5	CFB-4003-01UK	EARTH PLATE		1
****6	440-DS0010UK	LABEL DANGER HI VOLT	(1)-2	4
****104	400-100-012-01	PSU 12V 100W MW LPS-100-012-01		1
****105	400-075-024-01	PSU 24VDC 75W MW LPS-75-24		1
****106	400-075-005-01	PSU 5VDC 75W MW LPS-75-05		1
****108	838-14551-02UK	AC DISTRIBUTION BD		1
****109	400-065-0512-01	PSU 5V-12V DC 65W MW RPD-65C		1
****111	OS1011	PCB FEET RICHTO LCBS-L-5-01	(104)-4,(105)-4,(106)-4,(109)-4	16
****112	280-A01264-WX	ROUTER TWIST D12 SO6.4 WOOD X		10
****113	280-A02064-WX	ROUTER TWIST D20 SO6.4 WOOD X		8
****201	012-P00325	N4X1" S/TAP PAN PAS	(108)-4	4
****202	012-P03506-F	N6X1/4" S/TAP FLG PAS	(104)-4,(105)-4,(106)-4,(109)-4	16
****203	012-P03512-F	N6X1/2" S/TAP FLG PAS	(5)-2	2
****204	050-F00400	M4 NUT FLG SER PAS	(5)-4	4
****301	DA-60002UK	WH AC DIST		1
****302	DA-60003UK	WH AC TO GAMEBOARD		1
****303	DA-60004UK	WH DC DIST		1
****304	DA-60017UK	WH BASE TO SEAT		1

⑨ ASSY SW UNIT (DA-1320UK)

(D-1/1)

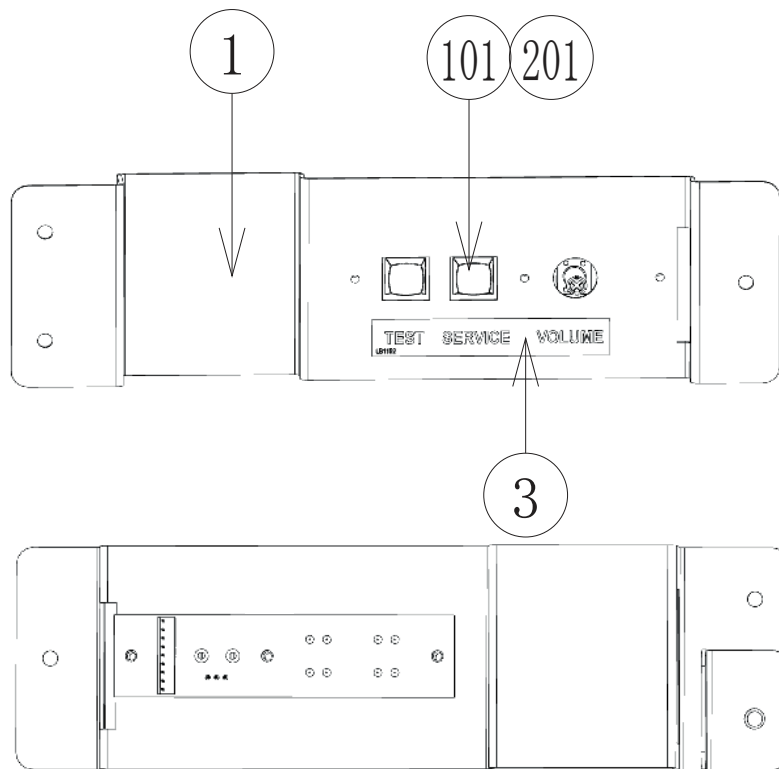

ITEM NO	PART NO	DESCRIPTION	REFERENCE	QTY
****1	DA-1321UK	BRKT SW MTG		1
****2				1
****3	LB1152	STICKER VTS		1
****101	838-14548-01UK	SW & VOL CTL BD		1
****201	020-B00308-0B	M3X8 SKT BH BLK	(101)-3	3
****202	068-441616	M4 WSHR 16OD FLT PAS	(2)-4	4

⑩ ASSY SW UNIT COVER (DA-1330UK)

(D-1/1)

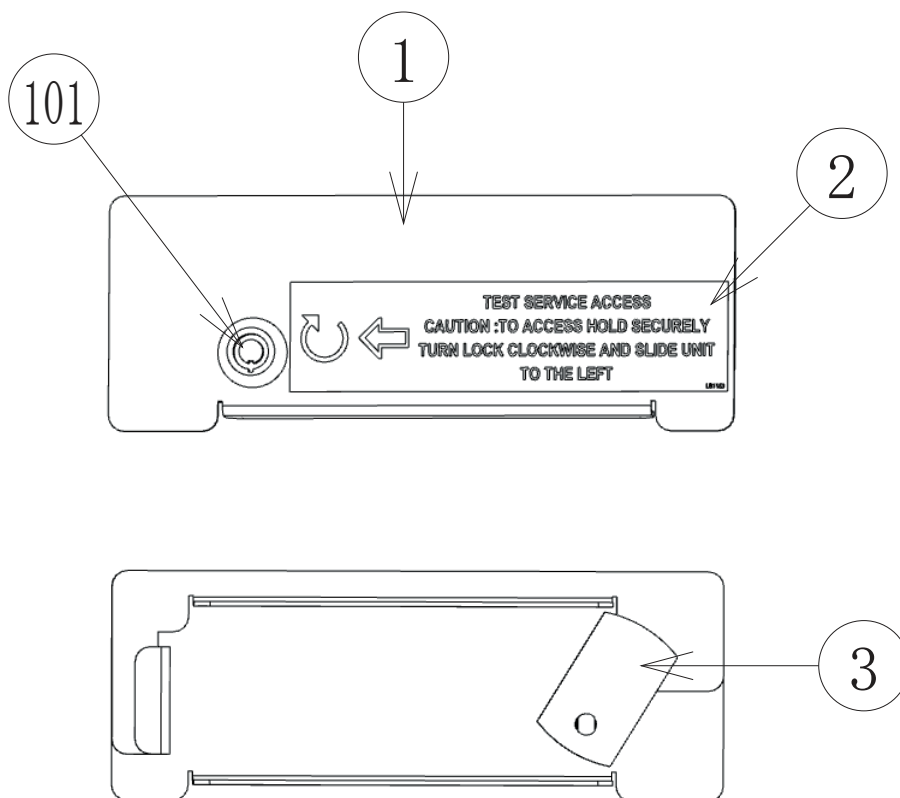

ITEM NO	PART NO	DESCRIPTION	REFERENCE	QTY
****1	DA-1322UK	COVER SW MTG		1
****2	LB1183	LABEL DA SWITCH UNIT COVER		1
****3	DP-1167UK	TNG LKG UK		1
****101	220-5575UK	LOCK (J9117)		1

⑪ ASSY CAMERA MODULE (DA-1350UK)

(D-1/1)

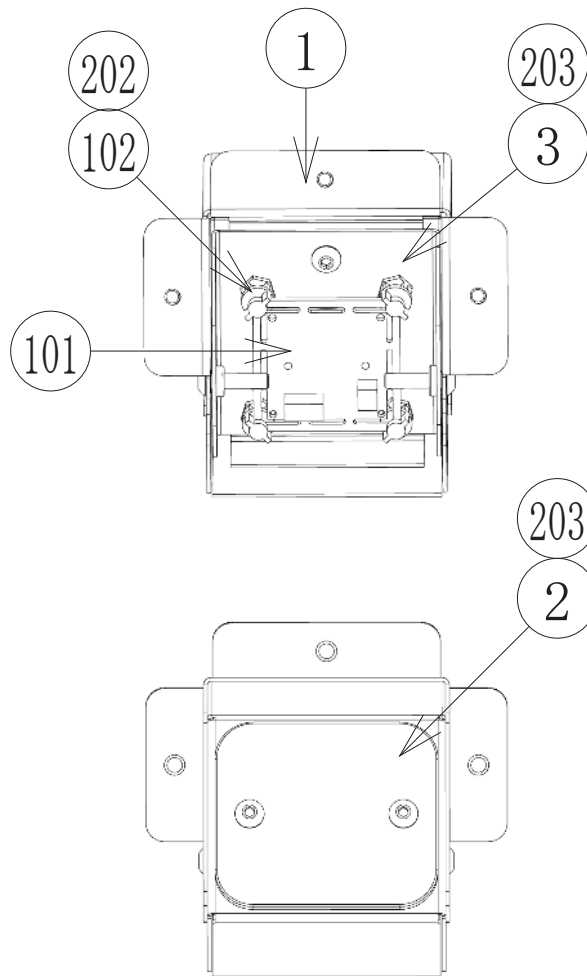

ITEM NO	PART NO	DESCRIPTION	REFERENCE	QTY
****1	DA-1351UK	BRKT SURROUND		1
****2	DA-1352UK	COVER CAMERA		1
****3	DA-1353UK	PLATE MTG CAMERA		1
****101	EP1483	CAMERA USB130W01MT		1
****102	280-0005UK	HOLDER EDGE PCB SCREW MNT (101)-4 6MM		4
****201			(101)-4	4
****202	012-P03506-F	N6X1/4" S/TAP FLG PAS	(102)-4	4
****203	029-B00412-0B	M4X12 SKT BH BLK	(2)-2,(3)-3	5

⑫ ASSY COIN CHUTE TOWER (DA-0300UK)

(D-1/1)

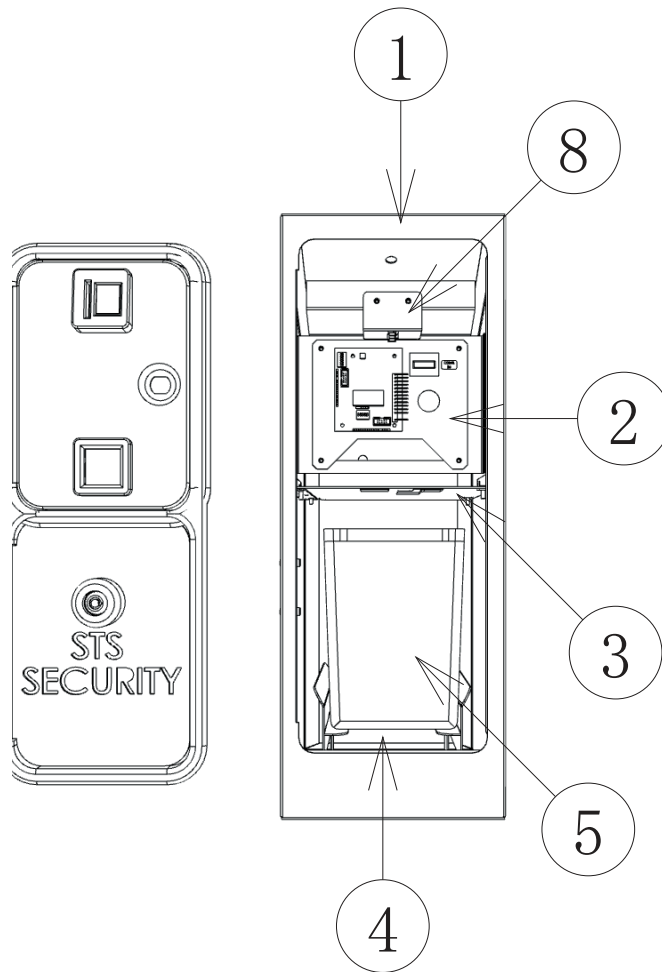

ITEM NO	PART NO	DESCRIPTION	REFERENCE	QTY
***1	DA-0301UK	COIN CHUTE TOWER		1
***2	DA-0320UK	ASSY EXCEL & METER UNIT		1
***3	RD--0352UK	COIN PATH PLATE		1
***4	DA-0302UK	CCT BASE CASHBOX		1
***5	PP1087	BOX CASH FOR MINI DOOR		1
***8	DSD-3104UK	BRKT COVER DBA HARNESS		1
***101	OS1247	ALUMINIUM STICKY CLIP ASK-3		1
***102	220-5374-01	DOOR DFMD W/FR&LOCK C120 EMEA SPEC UNIV		1
***103	220-5575UK	LOCK (J9117) KEY TO LIKE 22MM W coin door CAM		1
***201	029-B00412	M4X12 SKT BH PAS	(2)-4,(8)-2	6
***204	050-F00400	M4 NUT FLG SER PAS	(3)-4	4
***207	029-B00816-0B	M8X16 SKT BH BLK	(1)-2 HOLE INFILL LHS ONLY	2
***208	050-F00800	M8 NUT FLG SER PAS	(1)-2 HOLE INFILL LHS ONLY,(4)-2	4

⑬ ASSY EXCEL & METER UNIT (DA-0320UK)

(D-1/1)

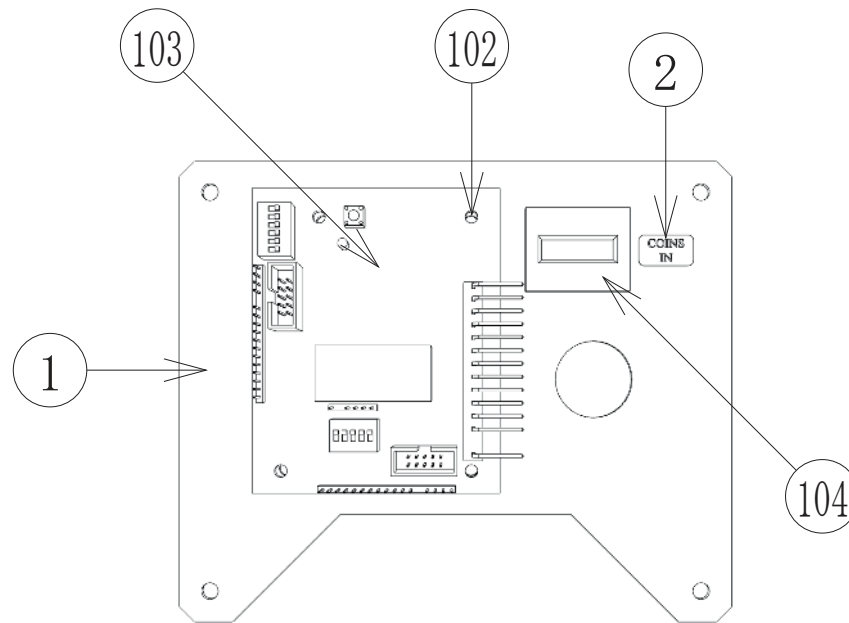

ITEM NO	PART NO	DESCRIPTION	REFERENCE	QTY
****1	DA-0321UK	BRKT BD MTG		1
****2	LB1165	STICKER COINS IN		1
****102	280-L00706-PM	STANDOFF 6.4MM HOLE PM	(103)-4	4
****103	EP1380-01	CREDIT BOARD EXCEL		1
****104	220-5643UK	COIN METER SMALL 12V		1
****105	OS1247	ALUMINIUM STICKY CLIP ASK-3		1
****106	OS1098	CRIMP BELL END SMALL		2
****107	601-0460	CABLE TIE NYLON 100MM		2
****301	DA-60013UK	WH COIN HANDLING		1

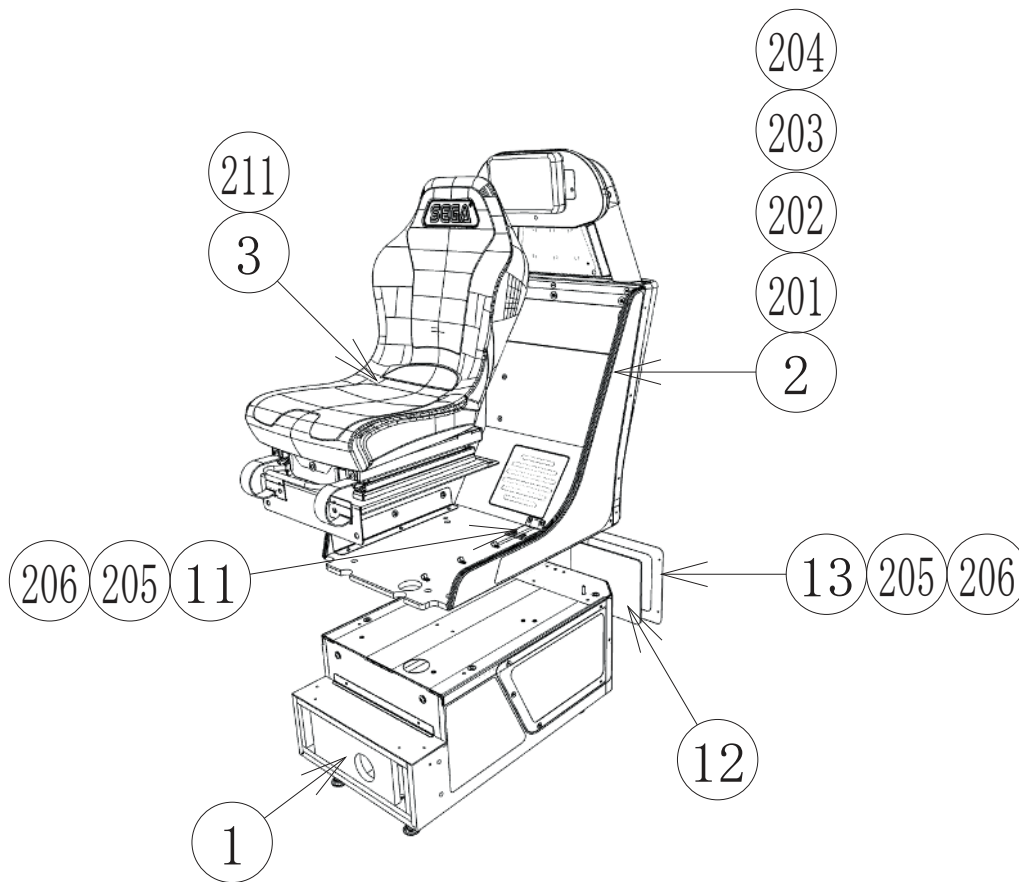

ITEM NO	PART NO	DESCRIPTION	REFERENCE	QTY
***1	DA-3600UK	ASSY SEAT BASE EXT		1
***2	DA-3700UK	ASSY ADJUSTABLE SEAT EXT		1
***3	DA-3750UK	ASSY UPPER SEAT EXT		1
***11	DA-3712UK	COVER HARNESS		1
***12	DA-3311UK	WINDOW REAR	UNDER (13)	1
***13	DA-3312UK	FRAME WINDOW REAR		1
***201	020-F00830-0B	M8X30 SKT CSK BLK	(2)-4	4
***202	029-B00830-0B	M8X30 SKT BH BLK	(2)-6	6
***203	060-S00800-0B	M8 WSHR SPR BLK	(2)-6	6
***204	068-852216-0B	M8 WSHR 22OD FLT BLK	(2)-6	6
***205	029-B00412-0B	M4X12 SKT BH BLK	(11)-4,(13)-4	8
***206	068-441616-0B	M4 WSHR 16OD FLT BLK	(11)-4,(13)-4	8
***209	029-B00425	M4X25 SKT BH PAS	(DA-0002UK)-2,(DA-0005UK)- 6 2,(DA-0006UK)-2	6
***210	068-441616	M4 WSHR 16OD FLT PAS	(DA-0002UK)-2,(DA-0005UK)- 6 2,(DA-0006UK)-2	6
***211	050-F00400	M4 NUT FLG SER PAS	(3)-2	2



16 ASSY SEAT BASE EXT (DA-3600UK)

(D-2/2)

ITEM NO	PART NO	DESCRIPTION	REFERENCE	QTY
**1	DA-3602UK	ASSY SEAT BASE EXT CABI		1
**2	DA-3350UK	ASSY ENGINE SUB		1
**3	DA-3303UK	BRKT END REAR		1
**4	DA-3604UK	BRKT SUPPORT CENTRE U EXT		1
**5	DA-3605UK	BRKT SUPPORT L EXT		1
**6	DA-3606UK	BRKT SUPPORT R EXT		1
**7	DA-3307UK	COVER LED WIDTH		1
**8	DA-3608UK	COVER LED SIDE EXT		2
**9	DA-3609UK	LID SEAT BASE EXT		1
**13	DA-3313UK	WINDOW SIDE	UNDER (15&16)	2
**14	DA-3314UK	SASH SEAT BASE		1
**15	DA-3315UK	FRAME WINDOW SIDE L		1
**16	DA-3316UK	FRAME WINDOW SIDE R		1
**17	DA-3617UK	LIGHT COVER BASE UPPER		2
**21	DA-3621UK	STICKER SEAT BASE LH SIDE EXT		1
**22	DA-3622UK	STICKER SEAT BASE RH SIDE EXT		1
***101			AROUND WINDOWS	3.8
***102	601-0460	CABLE TIE 100MM	(301)-6	6
***201	012-P03512-FB	N6x1/2" S/TAP FLG BLK	(2)-6,(7)-7,(8)-6,(17)-4	33
***202	029-B00630-0B	M6X30 SKT BH BLK	(3)-2	2
***203	029-B00825	M8X25 SKT BH PAS	(3)-5	5
***204	068-652016	M6 WSHR 20OD FLT PAS	(4)-5,(5)-2,(6)-2,(9)-4	13
***205	050-F00600	M6 NUT FLG SER PAS	(4)-5,(5)-2,(6)-2	9
***206	029-B00816	M8X16 SKT BH PAS	(5)-1,(6)-1	2
***207	060-S00800	M8 WSHR SPR PAS	(5)-1,(6)-1	2
***208	068-852216	M8 WSHR 22OD FLT PAS	(5)-1,(6)-1	2
***210			(12)-4	4
***211	068-441616-0B	M4 WSHR 16OD FLT BLK	(9)-1,(14)-2,(15)-2,(16)-2	7
***212	029-B00425-0B	M4X25 SKT BH BLK	(14)-2,(15)-3,(16)-3	8
***213	050-F00400	M4 NUT FLG SER PAS	(9)-1,(15)-3,(16)-3	7
***214	029-B00616	M6X16 SKT BH PAS	(9)-4	4
***215	060-S00600	M6 WSHR SPR PAS	(9)-4	4
***301	DA-60018UK	WH SEAT BASE		1
***302	DA-6003UK	ASSY LED ENGINE UPPER		2
***303	DA-6005UK	ASSY LED ENGINE LOWER		2
***304	DA-60023UK	WH LED CLIP DOUBLE		2
***305	BE-6001UK	ASSY LED CLIP		1

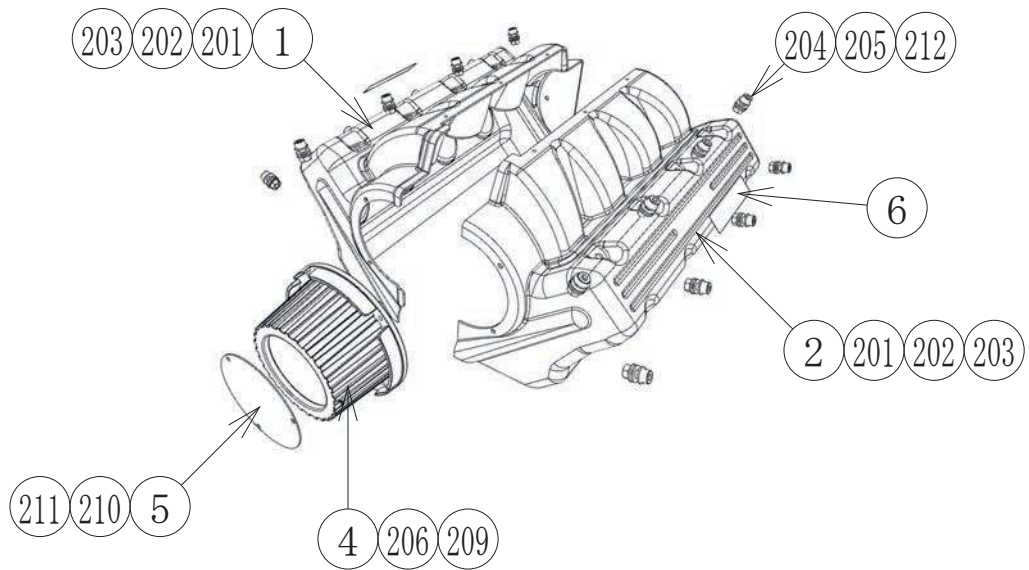

ITEM NO	PART NO	DESCRIPTION	REFERENCE	QTY
***1	DA-3351-01UK	ENGINE MOULD HALF L		1
***2	DA-3351-02UK	ENGINE MOULD HALF R		1
***4	601-12955-005	GUN MUZZLE COVER UL-HB		1
***5	TRF-2006UK	PLATE MUZZLE CLOSING		1
***6	DA-3353UK	STICKER COWLING LOGO		2
***201	029-B00625-0B	M6X25 SKT BH BLK	(1)-1,(2)-1	2
***202	068-652016-0B	M6 WSHR 200D FLT BLK	(1)-2,(2)-2	4
***203	050-F00600	M6 NUT FLG SER PAS	(1)-1,(2)-1	2
***204	020-0S0812	M8X12 SKT CAP STNLS	(1)-8,(2)-8	16
***205	060-F00800	M8 WSHR FORM A FLT PAS	(1)-16,(2)-16	32
***206	029-B00416-0B	M4X16 SKT BH BLK	(4)-4	4
***209	050-F00400	M4 NUT FLG SER PAS	(4)-4	4
***210	020-B00308-0B	M3X8 SKT BH BLK	(5)-3	3
***211	060-S00300	M3 WSHR SPR PAS	(5)-3	3
***212	050-F00800	M8 NUT FLG SER PAS	(1)-8,(2)-8	16

18 ASSY ADJUSTABLE SEAT EXT (DA-3700UK)

(D-1/2)

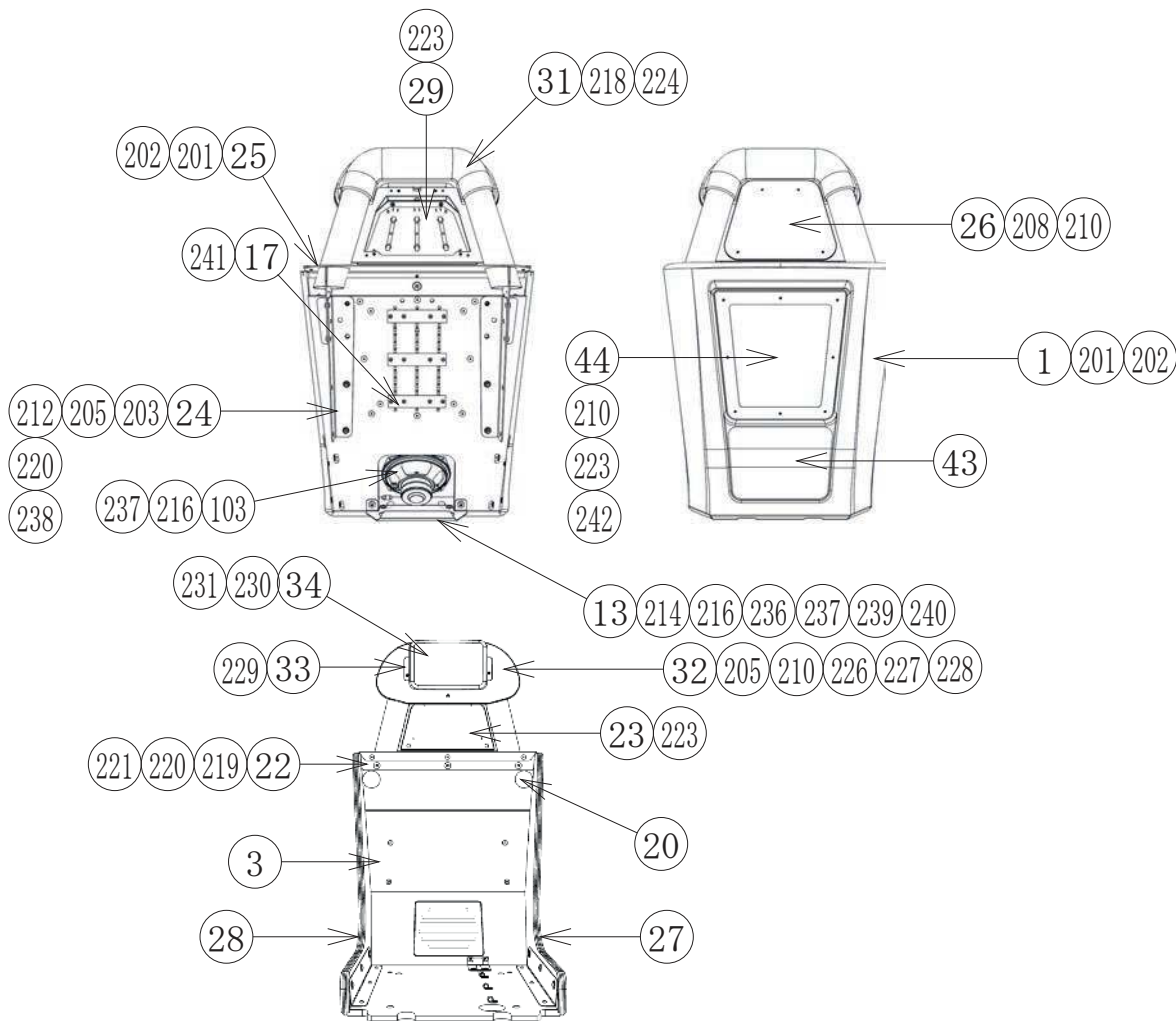

ITEM NO	PART NO	DESCRIPTION	REFERENCE	QTY
***1	DA-3401UK	SEAT MOULD REAR		1
***3	DA-3702UK	ASSY SEAT SURROUND CABI EXT		1
***13	DA-3714UK	BRKT MOULD REAR BTM RETAIN		1
***17	DA-3717UK	LIGHT COVER BACK PANEL		3
***20	LMA-9006UK	COVER FIXING PATCH		2
***22	DA-3421UK	FABRICATION SEAT TOP		1
***23	DA-3422UK	BOX LIGHT		1
***24	DA-3423UK	STRUT TOP HEADREST SECURE		2
***25	DA-3424UK	BRKT CLOSING TOP		1
***26	DA-3426UK	PANEL A FRAME		1
***27	DA-3727UK	STICKER SEAT CHEEK L EXT		1
***28	DA-3728UK	STICKER SEAT CHEEK R EXT		1
***29	DA-3429XUK	BASE MOUNT HEADREST		1
		BACKLIGHT		
***31	DA-3431UK	HEADREST MOULD REAR		1
***32	DA-3432UK	BLOCK CLOSING HEADREST REAR		1
***33	DV-3026UK	BRKT HOLDER HEADREST		1
***34	DV-3021UK	HEADREST		1
***43	DA-3445UK	STICKER MOULD REAR BTM		1
***44	DA-3446UK	NETTING PROTECTOR	(42)-UNDER	1
***103	130-020-04080	SPEAKER 4 OHM 80W WS 20E		1

18 ASSY ADJUSTABLE SEAT EXT (DA-3700UK)

(D-2/2)

ITEM NO	PART NO	DESCRIPTION	REFERENCE	QTY
***104	OS1198	P CLIP 11MM	(3)-3	3
***106	601-0460	CABLE TIE 100MM	WH	14
***201	029-B00416	M4X16 SKT BH PAS	(1)-8,(25)-5	13
***202	068-441616	M4 WSHR 16OD FLT PAS	(1)-8,(25)-5	13
***203	029-B00816-0B	M8X16 SKT BH BLK	(24)-5	10
***205	068-852216-0B	M8 WSHR 22OD FLT BLK	(24)-7,(32)-3	17
***208	029-B00412-0B	M4X12 SKT BH BLK	(26)-4	4
***210	068-441616-0B	M4 WSHR 16OD FLT BLK	(26)-4,(32)-4,(44)-8	16
***212	020-F00830-0B	M8X30 SKT CSK BLK	(24)-2	4
***214	068-652016-0B	M6 WSHR 20OD FLT BLK	(13)-4	4
***216	029-B00412	M4X12 SKT BH PAS	(13)-2,(103)-4,(104)-3	9
***218	068-652016	M6 WSHR 20OD FLT PAS	(31)-4	4
***219	029-B00825	M8X25 SKT BH PAS	(22)-3	3
***220	060-S00800	M8 WSHR SPR PAS	(22)-3,(24)-5	13
***221	068-852216	M8 WSHR 22OD FLT PAS	(22)-3	3
***223	050-F00400	M4 NUT FLG SER PAS	(23)-4,(29)-4,(44)-8,(301)-1	17
***224	029-B00616	M6X16 SKT BH PAS	(31)-4	4
***226	029-B00425-0B	M4X25 SKT BH BLK	(32)-4,(42)-8	12
***227	029-B00850-0B	M8X50 SKT BH BLK	(32)-1	1
***228	050-C00800-3B	M8 NUT DOME TYPE 3 B	(32)-1	1
***229	029-B00650-0B	M6X50 SKT BH BLK	(33)-2	2
***230	030-000525	M5X25 BLT PAS	(34)-3	3
***231	068-551616-0B	M5 WSHR 16OD FLT BLK	(34)-3	3
***236	060-F00400	M4 WSHR FORM A FLT PAS	(103)-4	4
***237	060-S00400	M4 WSHR SPR PAS	(13)-2,(103)-4	6
***238	050-F00800	M8 NUT FLG SER PAS	(24)-2	4
***239	029-B00616-0B	M6X16 SKT BH BLK	(13)-4	4
***240	060-S00600-0B	M6 WSHR SPR BLK	(13)-4	4
***241	012-P00412-FB	N8x1/2" S/TAP FLG BLK	(17)-4	12
***242	029-B00416-0B	M4X16 SKT BH BLK	(44)-8	8
***301	DA-60019UK	WH SEAT UPPER		1
***302	DA-60021UK	WH RGB TRIPLE		1
***303	DA-6002UK	ASSY SERIAL LED SEAT		1
***304	BE-6001UK	ASSY LED CLIP		3

19 ASSY ADJUSTABLE SEAT EXT (DA-3700UK)

(D-1/2)

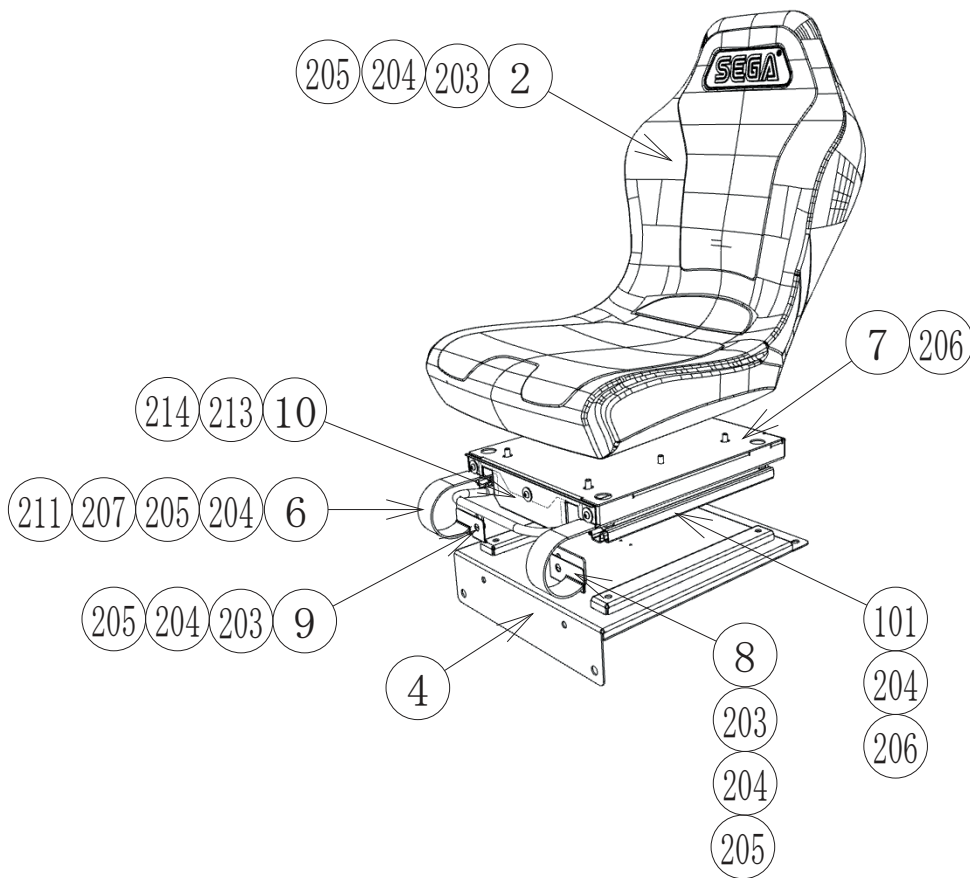

ITEM NO	PART NO	DESCRIPTION	REFERENCE	QTY
***2	253-5550UK-21B	PAN SEAT W LOGO SEGA BLACK		1
***4	DA-3703UK	SEAT BASE		1
***6	DA-3405UK	PROTECT RUBBER		2
***7	DA-3706UK	SEAT MOUNT TRAY		1
***8	DA-3407UK	RUBBER HOLDER L		1
***9	DA-3408UK	RUBBER HOLDER R		1
***10	DA-3711UK	TRAY COVER FRONT		1
***101	601-0006UK	SEAT SLIDE COBRA SEATS SUBFR07		1
***203	029-B00816-0B	M8X16 SKT BH BLK	(2)-6,(8)-1,(9)-1	8
***204	060-S00800-0B	M8 WSHR SPR BLK	(2)-6,(7)-4,(8)-1,(9)-1,(101)-4	6
***205	068-852216-0B	M8 WSHR 22OD FLT BLK	(2)-6,(6)-1,(8)-1,(9)-1	10
***206	029-B00830-0B	M8X30 SKT BH BLK	(7)-4,(101)-4	8
***207	050-U00800	M8 NUT NYLOK PAS	(6)-1	2
***211	060-F01200	M12 WSHR FORM A FLT	(6)-2	4
***213	029-B00612-0B	M6X12 SKT BH BLK	(10)-3	3
***214	068-652016-0B	M6 WSHR 20OD FLT BLK	(10)-3	3

20 ASSY INSTALLATION KIT (DA-INST-STD)

(D-1/2)

ITEM NO	PART NO	DESCRIPTION	REFERENCE	QTY
**2	DA-0800UK	ASSY BILLBOARD LIT W/MON		1
**3	DA-0002UK	SASH JOINT MID		1
**4	DA-0003UK	BRKT JOINT INNER L		1
**5	DA-0004UK	BRKT JOINT INNER R		1
**6	DA-0005UK	SASH JOINT L		1
**7	DA-0006UK	SASH JOINT R		1
**20	440-CS0186UK	STICKER C EPILEPSY MULTI		1
**21	DA-3425UK	INSERT A FRAME UNDER		1
***1	DA-3425-01UK	INSERT A FRAME UNDER NO 1		1
***2	DA-3425-02UK	INSERT A FRAME UNDER NO 2		1
***3	DA-3425-03UK	INSERT A FRAME UNDER NO 3		1
***4	DA-3425-04UK	INSERT A FRAME UNDER NO 4		1
***5	DA-3425-05UK	INSERT A FRAME UNDER NO 5		1
***6	DA-3425-06UK	INSERT A FRAME UNDER NO 6		1
***7	DA-3425-07UK	INSERT A FRAME UNDER NO 7		1
***8	DA-3425-08UK	INSERT A FRAME UNDER NO 8		1
**101	LM1227	UK MAINS LEAD 10A WITH PLUG	EMEA SPEC	1
**102	LM1246	EUROLEAD 10A EUROPEAN SOCKET	EMEA SPEC	1
**103	LM1500UK	MAINS LEAD USA/IEC	US SPEC	1
**205	029-B00616-0B	M6X16 SKT BH BLK	(2)-5	5
**206	060-S00600-0B	M6 WSHR SPR BLK	(2)-5	5
**207	068-652016-0B	M6 WSHR 20OD FLT BLK	(2)-5	5
**208	029-B00425	M4X25 SKT BH PAS	(3)-2,(6)-4,(7)-4	10
**209	068-441616	M4 WSHR 16OD FLT PAS	(3)-2,(6)-4,(7)-4	10
**210	029-B00850	M8X50 SKT BH PAS	(4)-4,(5)-4	8
**211	060-S00800	M8 WSHR SPR PAS	(4)-4,(5)-4	8
**212	068-852216	M8 WSHR 22OD FLT PAS	(4)-4,(5)-4	8
**301	600-7269-100UK	ASSY LAN CABLE 100CM		1
**401		MANUAL DAYTONA	This Manual	1
**403	OS1019	SELF SEAL BAG 9X12.3/4		1
**404		KEY CHIP RGW GST	253-5644-028BG	1
**405				1
**406			DECLARATION OF CONFORMITY DA	

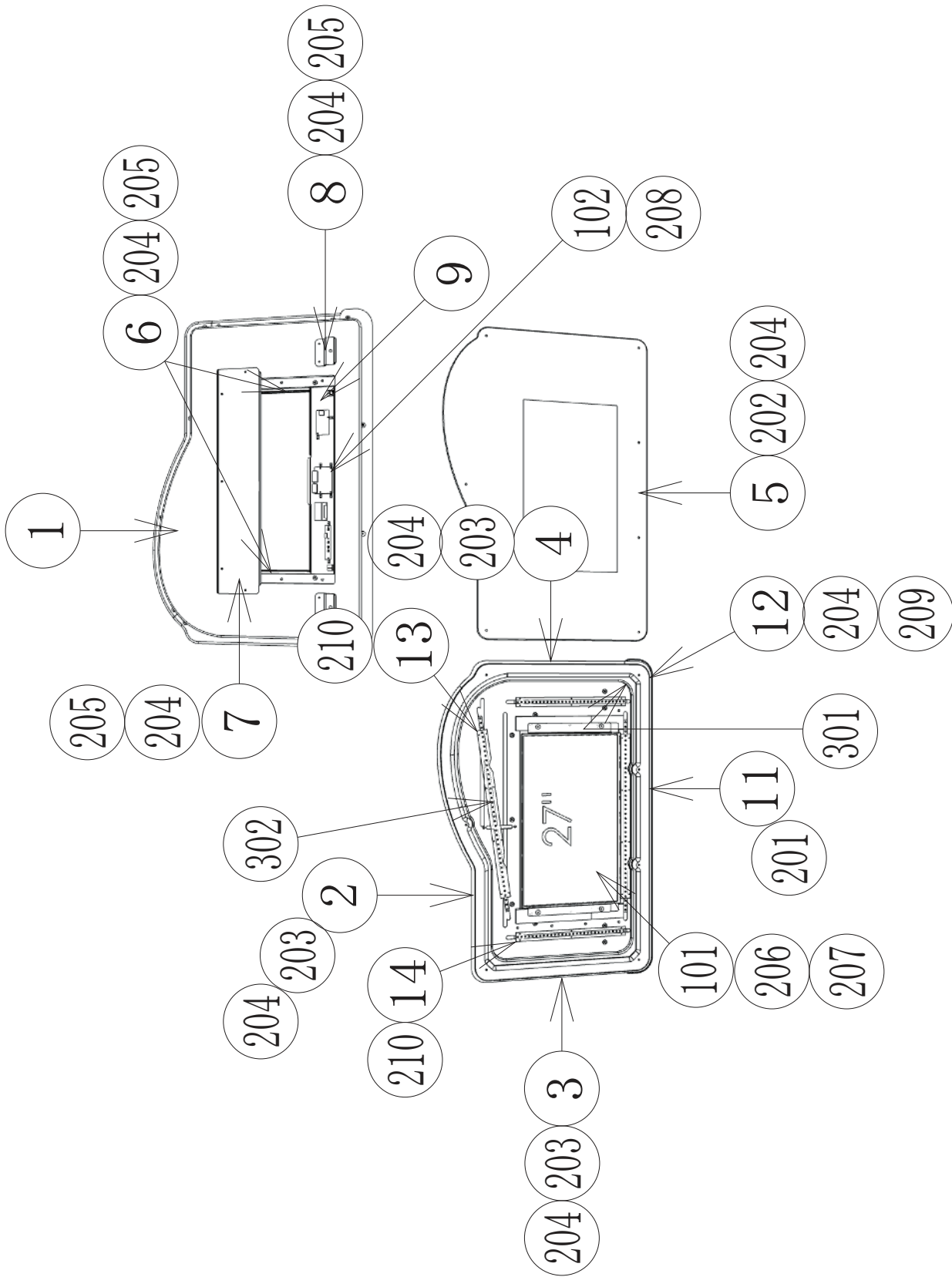

21 ASSY BILLBOARD W/MON (DA-0800UK)

(D-2/2)

ITEM NO	PART NO	DESCRIPTION	REFERENCE	QTY
***1	DA-0801UK	BB BASE BACK		1
***2	DA-0802UK	PANEL EDGE LIT TOP		1
***3	DA-0803UK	PANEL EDGE LIT L		1
***4	DA-0804UK	PANEL EDGE LIT R		1
***5	DA-0505UK	BB HEADER 27 MON		1
***6	DA-0506UK	BRKT MTG LED		2
***7	DA-0807UK	BRKT SUPPORT BB TOP		1
***8	DA-0508UK	BRKT SUPPORT BB BTM		2
***9	DA-0509UK	BRKT MTG AD BD	under (6)	1
***11	DA-0812UK	PANEL EDGE LIT BTM		1
***12	DA-0813UK	COVER EDGE LIT BTM PL		1
***13	DA-0814UK	LIGHT COVER BB LONG		2
***14	SSR-1225UK	LIGHT COVER CHEEK SHORT		2
***101	200-6027-AUO	27" LCD AUO M270HVN02.0		1
***102	OS1011	PCB FEET RICHCO LCBS-L-5-01	AD & PSU & OSD BD	8
***103	OS1230	FOAM STRIP 2mm X 10mm		0.16
***104	601-0460	CABLE TIE 100MM	(101)-WHs	12
***105	280-0014UK	BLIND HOLE CABLE TIE HOLDER		7
***201	000-F00416	M4X16 MSCR CSK	(11)-2	2
***202	020-OS0416	M4X16 SKT CAP STNLS	(5)-7	7
***203	029-B00412	M4X12 SKT BH PAS	(2)-4,(3)-2,(4)-2	8
***204	068-441616	M4 WSHR 16OD FLT PAS	(2)-4,(3)-2,(4)-2,(5)-7,(6)-2,(7)-5,(8)-2,(12)-4	32
***205	029-B00416	M4X16 SKT BH PAS	(6)-2,(7)-5,(8)-2	13
***206	020-B00203-0B	M2X3 SKT BH BLK	(101)-4	4
***207	060-S00200	M2 WSHR SPR PAS	(101)-4	4
***208	020-B00308-0B	M3X8 SKT BH BLK	(102)-1	8
***209	029-B00425	M4X25 SKT BH PAS	(12)-4	4
***210	012-P03512-FB	N6x1/2" S/TAP FLG BLK	(13)-8,(14)-6	28
***301	DA-6001UK	ASSY SERIAL LED BILLBOARD		1
***302	DA-6006UK	ASSY BILLBOARD RIGID		1

## 20 WIRE COLOUR CODE TABLE

### WARNING

The DC power wire color for this product is different from previous SEGA titles.  
Working from the previous wire colors will create a high risk of fire.

The color codes for the wires used in the diagrams in the following chapter are as follows.

A	PINK
B	SKY BLUE
C	BROWN
D	PURPLE
E	LIGHT GREEN

Wires other than those of any of the above 5 single colors will be displayed by 2 alphanumeric characters.

1	RED
2	BLUE
3	YELLOW
4	GREEN
5	WHITE
7	ORANGE
8	BLACK
9	GRAY

If the right-hand side numeral of the code is 0, then the wire will be of a single color shown by the left-hand side numeral (see the above).

Note 1: If the right-hand side numeral is not 0, that particular wire has a spiral color code. The left-hand side character shows the base color and the right-hand side one, the spiral color.

<Example> 51.....WHITE/RED



Note 2: The character following the wire color code indicates the size of the wire.

U:	AWG16
K:	AWG18
L:	AWG20
None:	AWG22





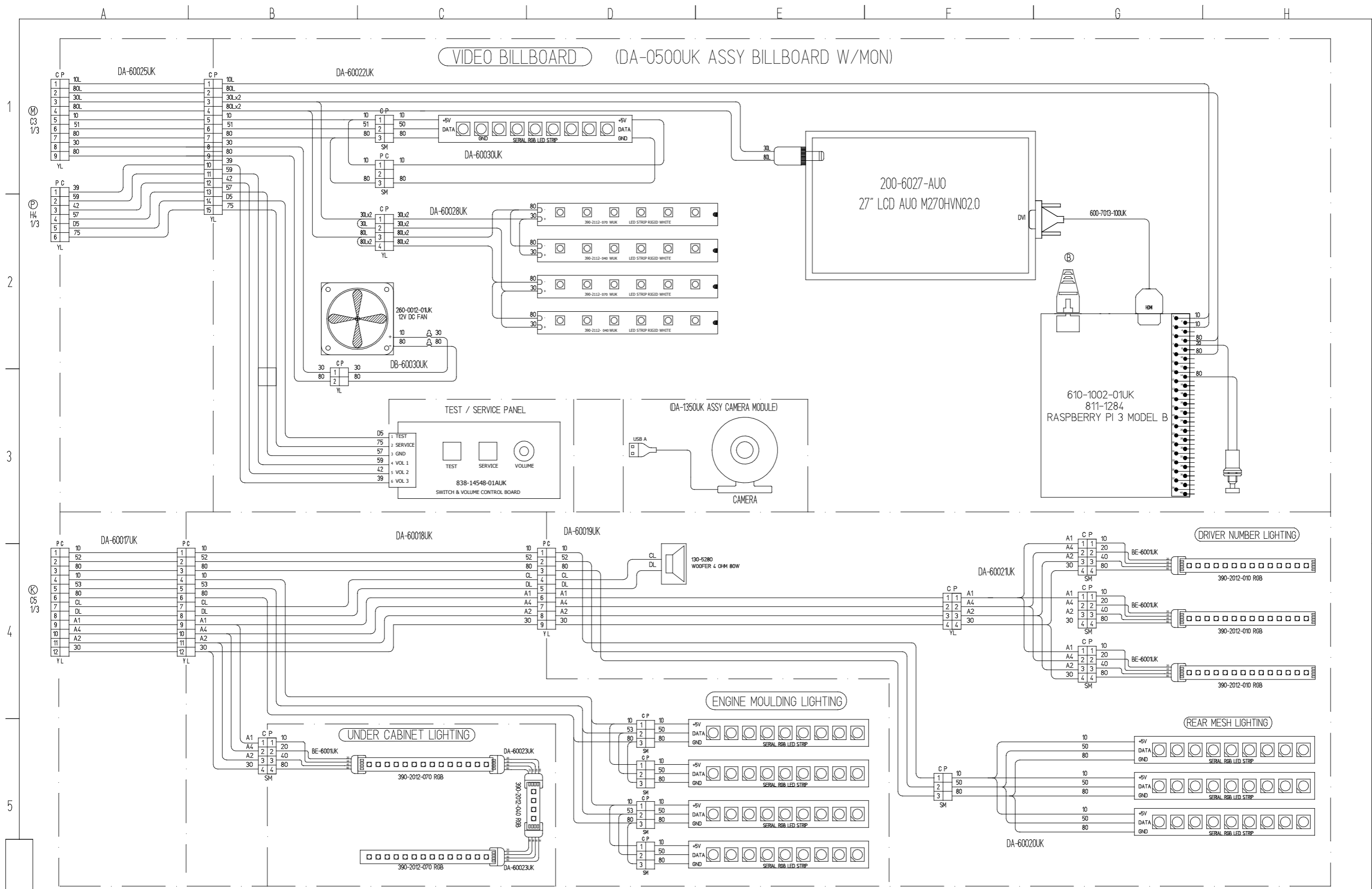

1 RED	8 BLACK	E LIGHT GREEN	
2 BLUE	9 GREY		
3 YELLOW	A PINK		U AWG 16 UL1015
4 GREEN	B SKY BLUE		K AWG 18 UL1015
5 WHITE	C BROWN		L AWG 20 UL1007
7 ORANGE	D PURPLE		AWG 22 UL1007

DRAWN	CHKD	D/CHKD	APPR
RA			

**SEGA** SEGA AMUSEMENTS EUROPE, LTD.  
DAYTONA CHAMPIONSHIP USA

THIS DRAWING WILL IN NO WAY BE COPIED.  
TO BE RETURNED ON DEMAND.  
PAGE 3 OF 3

ORIGINAL SIZE  
A3  
PART NBR.

# - SEGA TOTAL SOLUTIONS -

42 Barwell Business Park  
Leatherhead Road,  
Chessington,  
Surrey,  
KT9 2NY  
United Kingdom

Tel: +44 (0) 208 391 8060  
Fax: +44 (0) 208 391 8096



## Exclusive Suppliers of SEGA Spares

To Heathrow Airport

