

1st PRINTING APR 00

SEGA

EIGHTEEN 18 WHEELER™

☆☆☆ AMERICAN PRO TRUCKER ☆☆☆

STD VERSION OWNER'S MANUAL

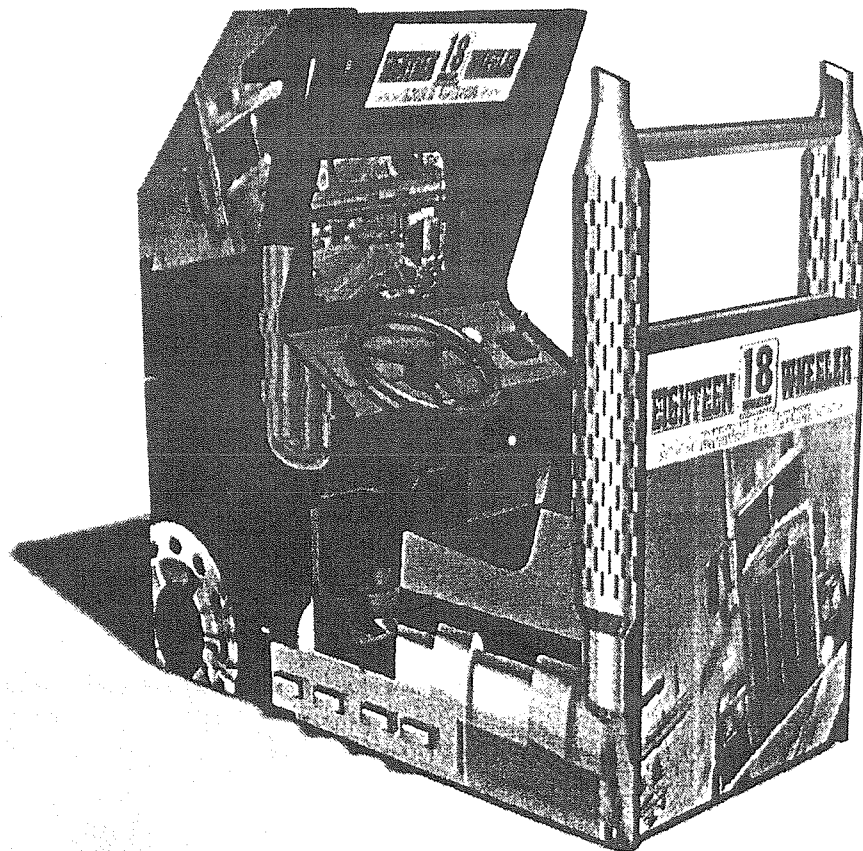

SEGA ENTERPRISES, INC. USA

MANUAL NO. 999-0921

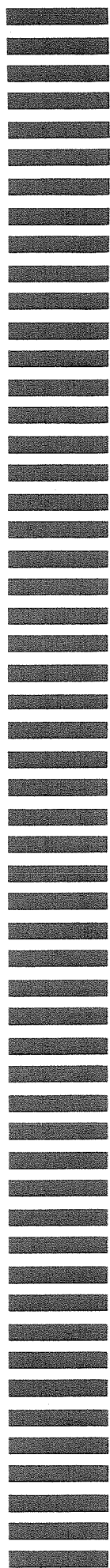

Warranty

Your new Sega Product is covered for a period of 90 days from the date of shipment. This certifies that the Printed Circuit Boards, Power Supplies and Monitor are to be free of defects in workmanship or materials under normal operating conditions. This also certifies that all Interactive Control Assemblies are to be free from defects in workmanship and materials under normal operating conditions. No other product in this machine is hereby covered.

Sellers sole liability in the event a warranted part described above fails shall be, at its option, to replace or repair the defective part during the warranty period. For Warranty claims, contact your Sega Distributor.

Should the Seller determine, by inspection that the product was caused by Accident, Misuse, Neglect, Alteration, Improper Repair, Installation or Testing, the warranty offered will be null and void.

Under no circumstances is the Seller responsible for any loss of profits, loss of use, or other damages.

This shall be the exclusive written Warranty of the original purchaser expressed in lieu of all other warranties expressed or implied. Under no circumstance shall it extend beyond the period of time listed above.

TABLE OF CONTENTS

INTRODUCTION OF THE OWNERS MANUAL	1
GENERAL PRECAUTIONS	2~3
1. PRECAUTIONS TO BE HEDED FOR OPERATION	4~5
2. NAME OF PARTS	6
3. ACCESSORIES	7~8
4. ASSEMBLY AND INSTALLATION	9~13
5. PRECAUTIONS TO BE HEDED WHEN MOVING MACHINE	14
6. CONTENTS OF GAME	15~19
7. EXPLANATION OF TEST AND DATA DISPLAY	20~34
7-1 SWITCH UNIT AND COIN METER	21
7-2 SYSTEM TEST MODE	22~28
A C.R.T. TEST	23
B COIN ASSIGNMENTS	24~28
7-3 GAME TEST MODE	29~34
A INPUT TEST	30
B OUTPUT TEST	30
C SOUND TEST	31
D VOLUME SETTING	31
E GAME ASSIGNMENTS	32
F BOOKKEEPING	33
G BACKUP DATA CLEAR	34
8. HANDLE MECHA	35~39
8-1 REMOVING THE CONTROL MECHANISM	35~37
8-2 VOLUME ADJUSTMENT/REPLACEMENT	38~39
9. SHIFT LEVER	40~41
9-1 REMOVING THE SHIFT LEVER	40
9-2 SWITCH REPLACEMENT	41
10. ACCELERATOR & BRAKE	42~44
10-1 REMOVING THE ACCELERATOR AND THE BRAKE	42
10-2 ADJUSTING OR REPLACING THE VOLUME	43~44
10-3 GREASING	44
11. COIN SELECTOR	45~48
12. MONITOR	49~51
12-1 CAUTIONS/WARNINGS FOR HANDLING	49~50
12-2 CAUTIONS TO BE HEDED WHEN CLEANING	50
12-3 ADJUSTMENT METHOD	51
13. REPLACEMENT OF FLUORESCENT LAMP AND BUTTONS	52~53
14. PERIODIC INSPECTION TABLE	54
15. TROUBLESHOOTING	55
16. GAME BOARD	56~57
16-1 LOCATING THE GAME BOARD	56
16-3 COMPOSITION OF THE GAME BOARD	57
18. DESIGN RELATED PARTS	58
19. PARTS LIST	59~79
20. WIRING DIAGRAMS	XXX

SPECIFICATIONS

Installation space:	34 in.(W) x 71 in.(D)
Height:	76 in.
Weight:	Approx. 450 lbs.
Power maximum current:	5 Amp AC 120V 60 Hz
MONITOR:	29" COLOR MONITOR

INTRODUCTION OF THE OWNERS MANUAL

SEGA ENTERPRISES, LTD., has for more than 30 years been supplying various innovative and popular amusement products to the world market. This Owners Manual is intended to provide detailed descriptions together with all the necessary installation, game settings and parts ordering information related to 18 WHEELER 'AMERICAN PRO TRUCKER' STD TYPE, a new SEGA product.

This manual is intended for those who have knowledge of electricity and technical expertise, especially in ICs, CRTs, microprocessors, and circuit boards. Read this manual carefully to acquire sufficient knowledge before working on the machine. Should there be a malfunction, non-technical personnel should under no circumstances touch the interior system. Should the need arise, contact our main office, or the closest branch office listed below.

SEGA ENTERPRISES, INC. (USA)

Customer Service

45133 Industrial Drive

Fremont, CA 94538

Phone 415-701-6580

Fax 415-701-6594

7:30 am - 4:00 pm, Pacific Standard Time

Monday thru Friday

General Precautions

Follow Instructions: All operating and use instructions should be followed.

Attachments: Do not use attachments not recommended by the product manufacturer as they may cause hazards.

Accessories: Do not place this product on an unstable cart, stand, tripod, bracket, or table. The product may fall, causing serious injury to a child or adult, and serious damage to the product. Use only with a cart, stand, tripod, bracket, or table recommended by the manufacturer, or sold with the product. Any mounting of the product should follow the manufacturer's instructions, and should use only mounting accessories recommended by the manufacturer.

Moving the Product: This product should be moved with care. Quick stops, excessive force, and uneven surfaces may cause the product to overturn.

Ventilation: Slots and openings in the cabinet are provided for ventilation, to ensure reliable operation of the product and to protect it from overheating; these openings must not be blocked or covered. The openings should never be blocked by placing the product in a built-in installation such as a bookcase or rack unless proper ventilation is provided or the manufacturer's instructions have been adhered to.

Power Sources: This product should be operated only from the type of power source indicated on the marking label. If you are not sure of the type of power supply to your location, consult your local power company. For products intended to operate from battery power or other sources, refer to the operating instructions.

Grounding or Polarization: This product is equipped with a three-wire grounding-type plug, a plug having a third (grounding) pin. This plug will only fit into a grounding-type power outlet. This is a safety feature. If you are unable to insert the plug into the outlet, contact your electrician to replace your obsolete outlet. Do not defeat the safety purpose of the grounding-type plug.

Power Cord Protection: Power-supply cords should be routed so that they are not likely to be walked on or pinched by items placed upon or against them, paying particular attention to cords at plugs, convenience receptacles, and the point where they exit from the product.

Overloading: Do not overload wall outlets, extension cords, or integral convenience receptacles as this can result in a risk of fire or electric shock.

Object and Liquid Entry: Never push objects of any kind into this product through openings as they may touch dangerous voltage points or short-out parts that could result in a fire or electric shock. Never spill liquid of any kind on the product.

Servicing: Do not attempt to service this product yourself as opening or removing covers may expose you to dangerous voltage or other hazards. Refer all servicing to qualified service personnel.

Damage Requiring Service: Unplug this product from the wall outlet and refer servicing to qualified service personnel under the following conditions:

- a) If the power cord or plug is damaged;
- b) If liquid has been spilled, or objects have fallen into the product;
- c) If the product has been exposed to rain or water;
- d) If the product does not operate normally when following the operating instructions. Adjust only those controls that are explained in the operating instructions. An improper adjustment of other controls may result in damage and will often require extensive work by a qualified technician to restore the product to its normal operation;
- e) If the product has been dropped or damaged in any way;
- f) When the product exhibits a distinct change in performance; this indicates a need for service.

Replacement Parts: When replacement parts are required, be sure the service technician has used replacement parts specified by the manufacturer or that have the same characteristics as the original part. Unauthorized substitutions may result in fire, electric shock, or other hazards.

Safety Check: Upon completion of any service or repairs to this product, ask the service technician to perform safety checks to determine that the product is in proper operating condition.

Heat: The product should be situated away from heat sources such as radiators, heat registers, stoves, or other products (including amplifiers) that produce heat.

Lithium Battery- Dispose of batteries only in accordance with the battery manufacturer's recommendations. Do not dispose in an open flame condition, since the battery may explode.

Cleaning: When cleaning the monitor glass, use water or glass cleaner and a soft cloth. Do not apply chemicals such as benzine, thinner, etc.

Location: This an indoor game machine, DO NOT install it outside. To ensure proper usage, avoid installing indoors in the places mentioned below:

- Places subject to rain/water leakage, or condensation due to humidity;
- In close proximity to a potential wet area;
- Locations receiving direct sunlight;
- Places close to heating units or hot air;
- In the vicinity of highly inflammable/volatile chemicals or hazardous matter;
- On sloped surfaces;
- In the vicinity of emergency response facilities such as fire exits and fire extinguishers;
- Places subject to any type of violent impact;
- Dusty places.

INSTALLATION PRECAUTIONS

- Verify the amperage of the branch circuit outlet before plugging in the power plug. Do not overload the circuit.
- Avoid using an extension cord. If one is required, use an extension cord of type SJT, 16/3 AWG rated min. 120 VAC, 7A.
- Moving this unit requires a minimum clearance (of doors, etc.) of 32" (W) by 77" (H).
- For the operation of this machine, secure a minimum area of 32" (W) by 42"(D).

REGULATORY APPROVALS

This game has been tested and found to comply with the Federal Communications Commission Rules.

This device complies with Part 15 of the FCC Rules. Operation is subject to the following two conditions: (1) This device may not cause harmful interference, and (2) this device must accept any interference received, including interference that may cause undesired operation.

This game has been tested and listed by Underwriters Laboratories, Inc., to ANSI/UL22.



AMUSEMENT MACHINE

1 . PRECAUTIONS TO BE HEDED FOR OPERATION

In order to prevent accidents, be sure to comply with the following points before and during operation.

PRECAUTIONS TO BE HEDED FOR OPERATION BEFORE STARTING THE OPERATION



- In order to avoid accidents, check the following before starting the operation:
Check if all of the adjusters are in contact with the surface. If they are not, the cabinet can move and cause an accident.

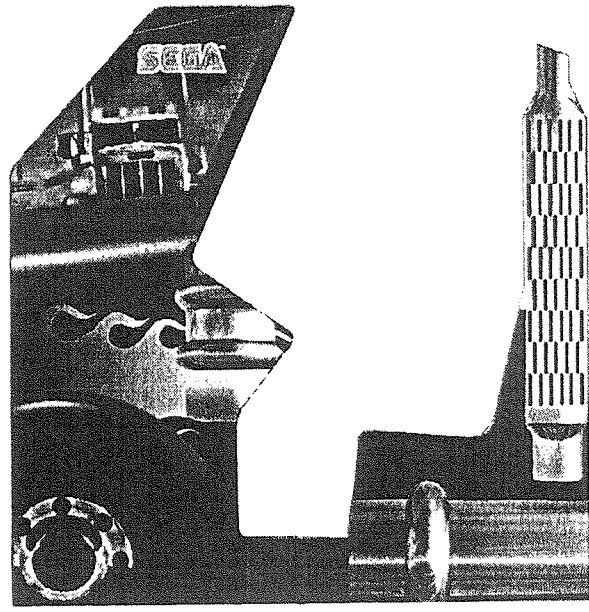

- Do not climb on the product. Climbing on the product can cause falling accidents. To check the top portion of the product, use a step.
- To avoid electric shock, check to see if door & cover parts are closed.
- To avoid electric shock, short circuit and or parts damage, do not put the following items on or in the periphery of the product:
- Flower vases, flower pots, cups, water tanks, cosmetics, and receptacles/containers/vessels containing chemicals and water.



To avoid injury, be sure to provide sufficient space by considering the potentially crowded situation at the installation location. Insufficient installation space can cause the player to come into contact with or hit others and result in injury or trouble.

PRECAUTIONS TO BE HEEDED DURING OPERATION



CAUTION!

To avoid injury and accidents, those who fall under the following categories are not allowed to play the game:

- * Intoxicated persons
- * Those who have high blood pressure or heart problems.
- * Those who have experienced muscle convulsion or loss of consciousness when playing video games, etc.
- * Persons susceptible to motion sickness.
- * Persons whose acts runs counter to the products warning displays.

* Instruct those who wear high-heeled shoes to refrain from playing the game by explaining that playing the game with high-heeled shoes is very dangerous and likely to cause a potentially hazardous situation.



CAUTION!

- To avoid electric shock and short circuit, do not allow customers to put hands and fingers or extraneous matter in openings of the product or small openings in or around doors.
- To avoid electric shock and short circuit, do not allow the customers to unplug the power plug without a justifiable reason.
- Although this product has the accident preventive covering attached to potentially hazardous places where hand and fingers could be caught, small children are unable to perceive hazards. Use care so that small children do not come close to the product when in play.
- Immediately stop such violent acts as hitting and kicking the product. Such violent acts can cause parts damage and/or falling down, resulting in injury due to fragments and falling down.

2 . NAME OF PARTS

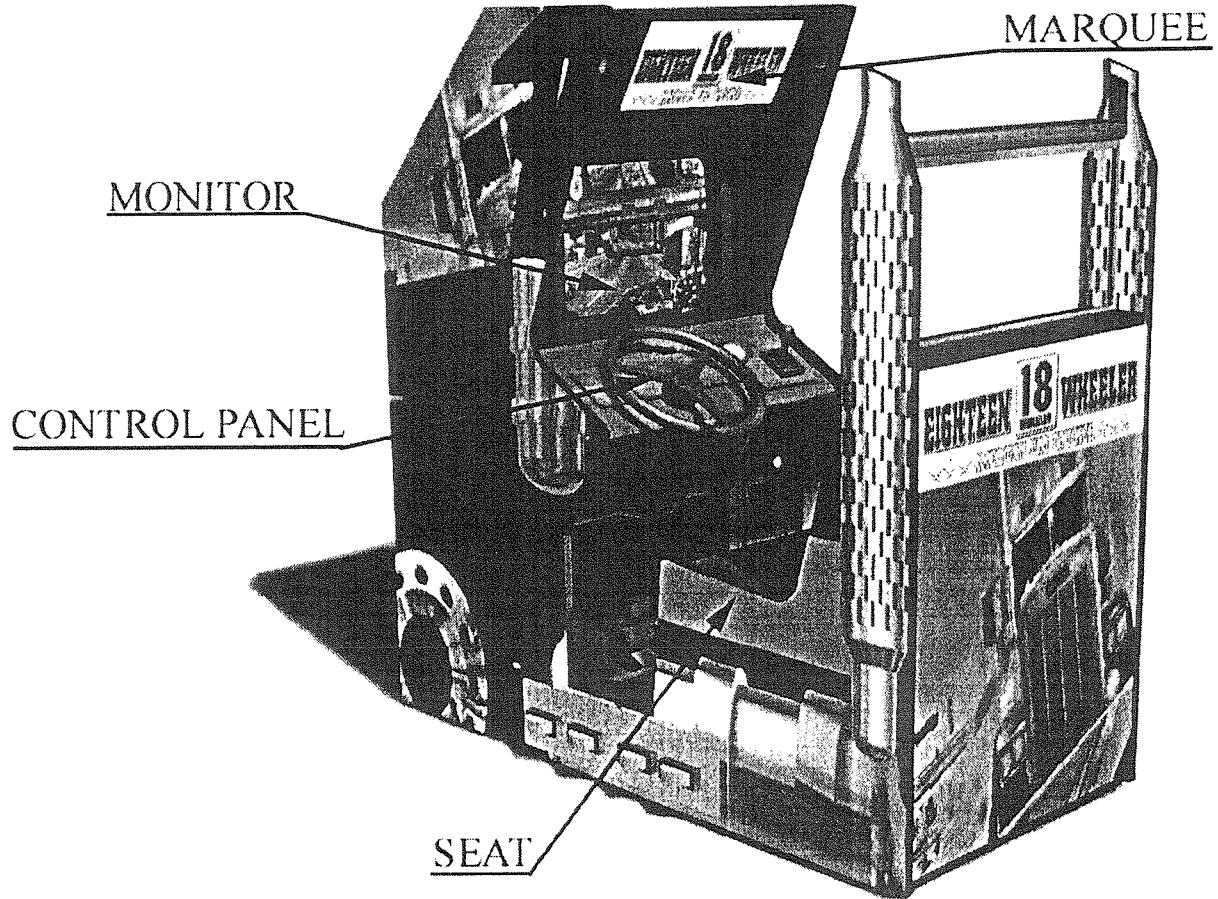

GAME SPECIFICATIONS	WIDTH in.	LENGTH in.	HEIGHT in.	WEIGHT lbs.
	All measurements are and rounded UP			
DURING SHIPPING	40"	X 77"	X 84"	500 LBS.
WHEN ASSEMBLED	34"	X 71"	X 76"	450 LBS.

3 . ACCESSORIES

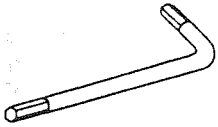
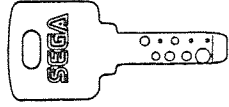
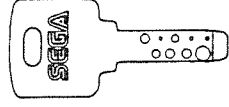
<p>DESCRIPTION OWNERS MANUAL Part No. (Qty.) 999-0921 Note Figures If Part No. has no description, the Number has not been registered or can not be registered. Such a part may not be obtainable even if the customer desires to purchase it. Therefore, ensure that the part is in safekeeping with you.</p>	<p>KEY MASTER 220-5576 (2) For opening/closing the doors</p>	<p>KEY (2) For the CASHBOX DOOR</p>
<p>TAMPERPROOF WRENCH M8 540-0009-01 (1) TOOL</p> 		



CAUTION!

THE SHIPMENT METHOD DESCRIBED BELOW ONLY APPLIES TO 'MODEL 3' BOARDS CONTAINED IN THE FOLLOWING GAMES:

LOST WORLD, VIRTUA FIGHTER 3, SUPER GT, SEGA BASS FISHING, STRIKER 2 HARLEY DAVIDSON, RALLY 2, DAYTONA 2, DIRT DEVILS, HOUSE OF THE DEAD 2, OCEAN HUNTER, STAR WARS TRILOGY, ZOMBIE REVENGE, CRAZY TAXI, AIRLINE PILOTS, 18 WHEELER

!!NEVER SHIP MODEL 3 / NAOMI GAME BOARDS OUTSIDE OF CAGE!!

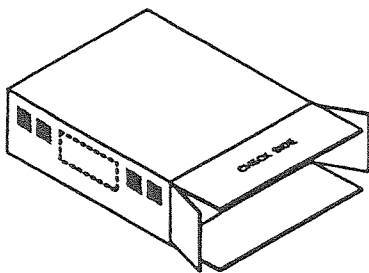

CARTON BOX
601-8928 (1)
Used for transporting the GAME BOARD.
(SUPPLIED WITH YOUR GAME)

DO NOT SHIP GAME BOARD WITHOUT THIS BOX AS IT MAY DAMAGE THE GAME BOARD AND VOID YOUR WARRANTY.

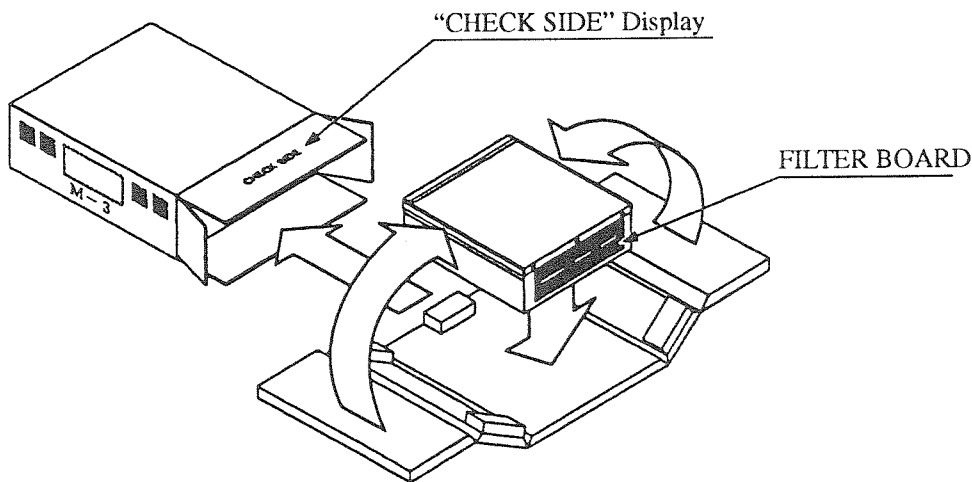

WARNING!

NO OTHER GAMES BOARDS ARE TO BE SHIPPED IN THE CAGE AS THEY MAY BE DAMAGED BEYOND REPAIR. PLEASE SHIP THEM WITHOUT CAGE PROPERLY PROTECTED DURING SHIPPING.

4 . ASSEMBLING AND INSTALLATION



- Assembling should be performed as per this manual. Since this is a complex machine, erroneous assembling may cause damage to the machine, or malfunctioning to occur.
- When assembling, be sure to perform work by plural persons. Depending on the assembly work, there are some cases in which a single person performing the work can cause personal injury or parts damage.
- Be careful so as not to damage wirings. Damaged wiring can cause electric shock and short circuit hazards.

When carrying out the assembly work, follow the procedure in the following 5-item sequence:

- 1 ASSY OF THE CABINET
- 2 SECURING IN PLACE (ADJUSTER ADJUSTMENT)
- 3 POWER SUPPLY
- 4 ASSEMBLING CHECK

Note that the tools such as a phillips screwdriver and wrench for M16 hexagon bolt w/24 mm width across flats are required for the assembly work.

- 1 ASSY OF CABINET



Permanently tightening the hex bolts should not be completed until the leg levelers are adjusted properly.

NOTE: Game is shipped fully assembled. No assembly required.

2

SECURING IN PLACE (ADJUSTER ADJUSTMENT)



Be sure to have all the Adjusters make contact with the floor surface. Unless the Adjusters come into contact with the floor surface, the Cabinet can move of itself, causing an accident.

This machine has 4 each of casters and adjusters (shown below). When the installation position is determined, cause the adjusters to come into contact with the floor directly, make adjustments in a manner so that the casters will be raised approximately 5mm. from the floor and make sure that the machine position is level.

- ① Move the machine to the installation position. Be sure to provide adequate space allowing the player to get on and off.
- ② Have all of the Leg Adjusters make contact with the floor. Adjust the height of the Leg Adjusters by using a wrench so that the machine's position is kept level.
- ③ After making adjustments, fasten the leg Adjuster Nut upward and secure the height of the Leg Adjuster.

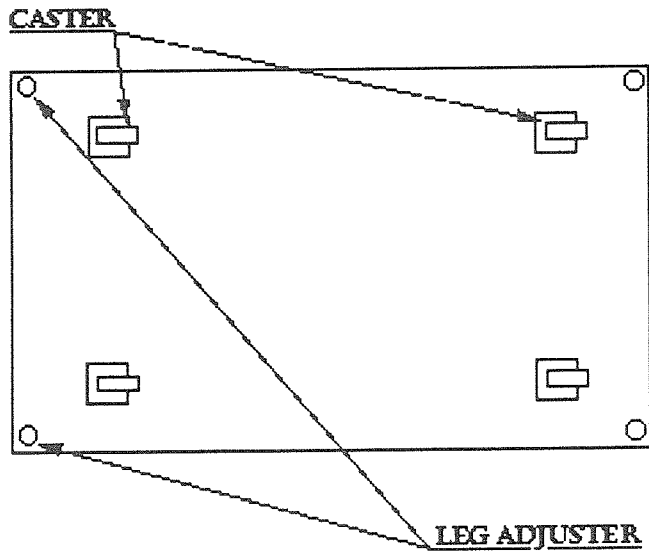
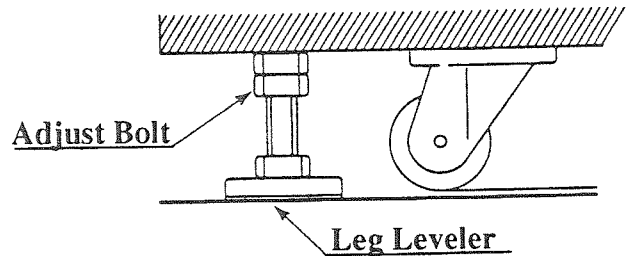

3

POWER SUPPLY



WARNING!

- Ensure that the power cord is not exposed on the surface (passage, etc.). If exposed, they can be caught and are susceptible to damage. If damaged, the cord can cause an electric shock or short circuit.
- Ensure that the wiring position is not in the customer's passage way or the wiring has protective covering.

Connect the game to the power supply and turn on power to the game. Before connecting power supply be sure that power switch is off

- ① Turning the AC unit's main switch on will cause the machine to start the power check and network check automatically.
- ② In the Power On check, the steering wheel turns left and right, and then returns to the centering position and stops. In this check, the values of the VR inside the control panel are corrected.
- ③ Until this check is finished, and the steering wheel stops, do not touch the steering wheel or play the game.

If you do, the steering reaction during the game (reaction at the time of course-out or crash) can not be obtained correctly. In the case of an abnormal reaction during the game, turn power on again from the beginning and complete the power on check.

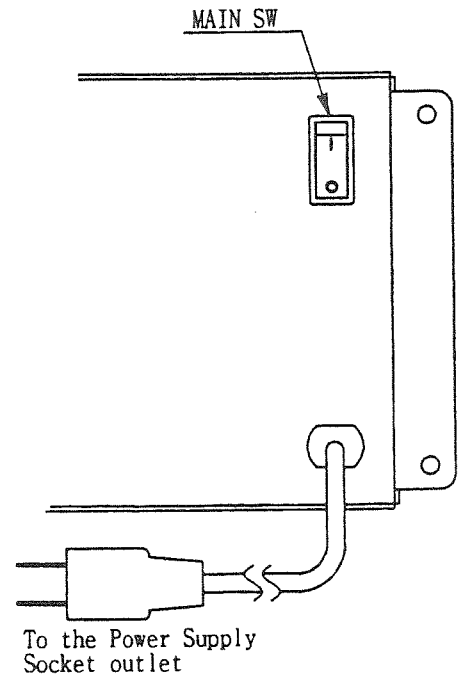

4

ASSEMBLING CHECK

In the TEST MODE, ascertain that the assembly has been made correctly and that the IC BOARD is satisfactory.

In the test mode, perform the following test:

(1) MEMORY TEST

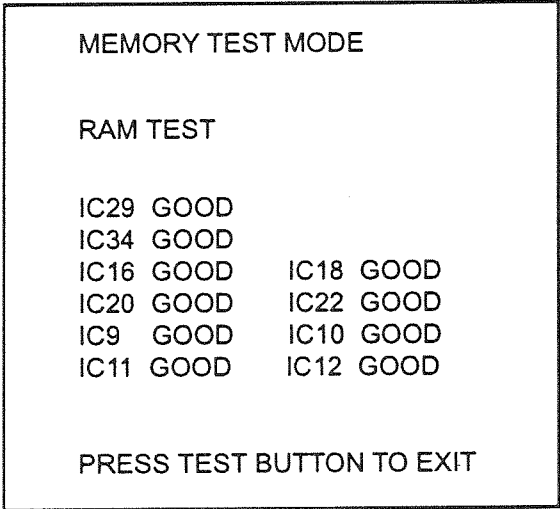

Selecting the RAM TEST item on the test mode menu screen causes the on-board memory to be tested automatically. The game board is satisfactory if the display beside each IC No. shows GOOD.

(2) C.R.T. TEST

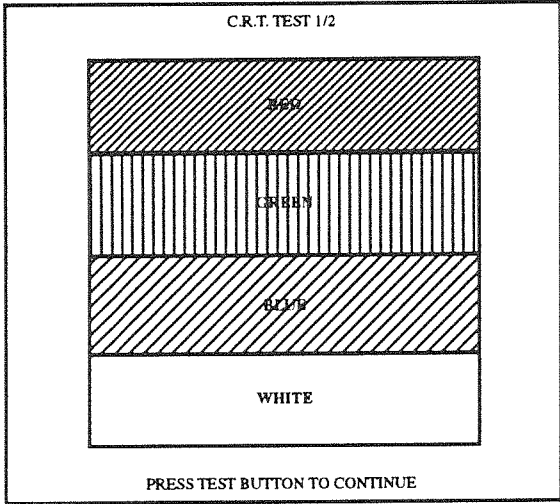

In the TEST mode menu, selecting C.R.T. TEST allows the screen (on which the monitor is tested) to be displayed. Although the monitor adjustments have been made at the time of shipment from the factory, color deviation, etc., may occur due to the effects of geomagnetism, the location of the building's steel frames and other game machines in the periphery. By watching the test mode screen, make judgement as to whether an adjustment is needed. If it is necessary, adjust the monitor by referring to Chapter 12.

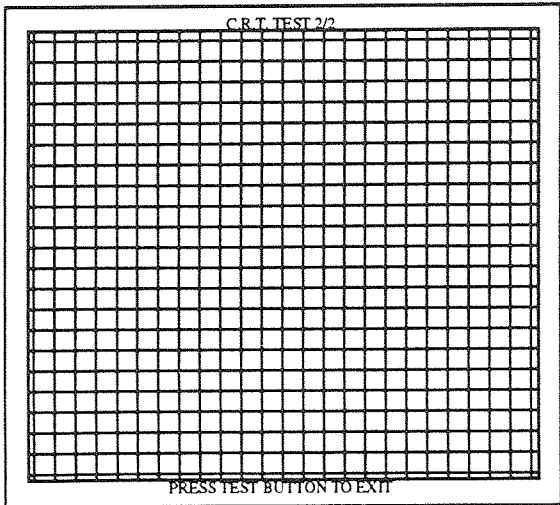

(3) INPUT TEST

INPUT TEST	
COIN CHUTE #1	OFF
COIN CHUTE #2	OFF
SERVICE	OFF
TEST	OFF
START	OFF
VIEW	OFF
HORN	OFF
SHIFT [L]	OFF
SHIFT [H]	OFF
SHIFT [R]	OFF
HANDLE	XXH
ACCEL	XXH
BRAKE	XXH

PRESS TEST + SERVICE BUTTON TO EXIT

Selecting the INPUT TEST on the test mode menu screen causes the screen (on which each switch is tested) to be displayed. Press each switch. For the coin switch test, insert a coin into the coin inlet with the coin chute door open. If the display beside each switch indicates "ON," the switch and wiring connections are satisfactory.

(4) OUTPUT TEST

OUTPUT TEST	
START LAMP	OFF
VIEW LAMP	OFF
HORN LAMP	OFF
ROLL LEFT	OFF
ROLL RIGHT	OFF

->EXIT

SELECT WITH SERVICE BUTTON
AND PRESS TEST BUTTON

Select OUTPUT TEST from the menu in the test mode to cause the screen (on which each lamp and wiring connection is tested) to appear. Ensure that each lamp lights up satisfactorily.

(5) SOUND TEST

SOUND TEST	
B.G.M.	0/ XX
EFFECT	0/ XX
[_____]	
ICS	0/ XX
[_____]	

-> EXIT

SELECT WITH SERVICE BUTTON
AND PRESS TEST BUTTON

In the TEST mode, selecting SOUND TEST causes the screen, on which sound related BD and wiring connections are tested, to be displayed. Be sure to check if the sound is satisfactorily emitted from each speaker and that the sound volume is appropriate.

Perform the above inspections also at the time of monthly inspection.

5 . PRECATIONS TO BE HEEDED WHEN MOVING THE MACHINE



WARNING!

- When moving the machine, be sure to pull out the plug from the power supply. Moving the machine with the plug inserted can damage the power cord and cause a fire or electric shock.
- When moving the machine on the floor, retract the Adjusters and ensure that Casters make contact with the floor. During transportation, pay careful attention so that Casters do not tread power cords. Damaging the power cords can cause an electric shock and/or short circuit.
- When lifting the cabinet, be sure to hold the catch portions or bottom part. Lifting the cabinet by holding other portions can damage parts and installation portions, due to the empty weight of the cabinet, and cause personal injury.



CAUTION!

Do not push on the plastic parts. Doing so may damage the parts and cause injury due to fragments resulting from damage.

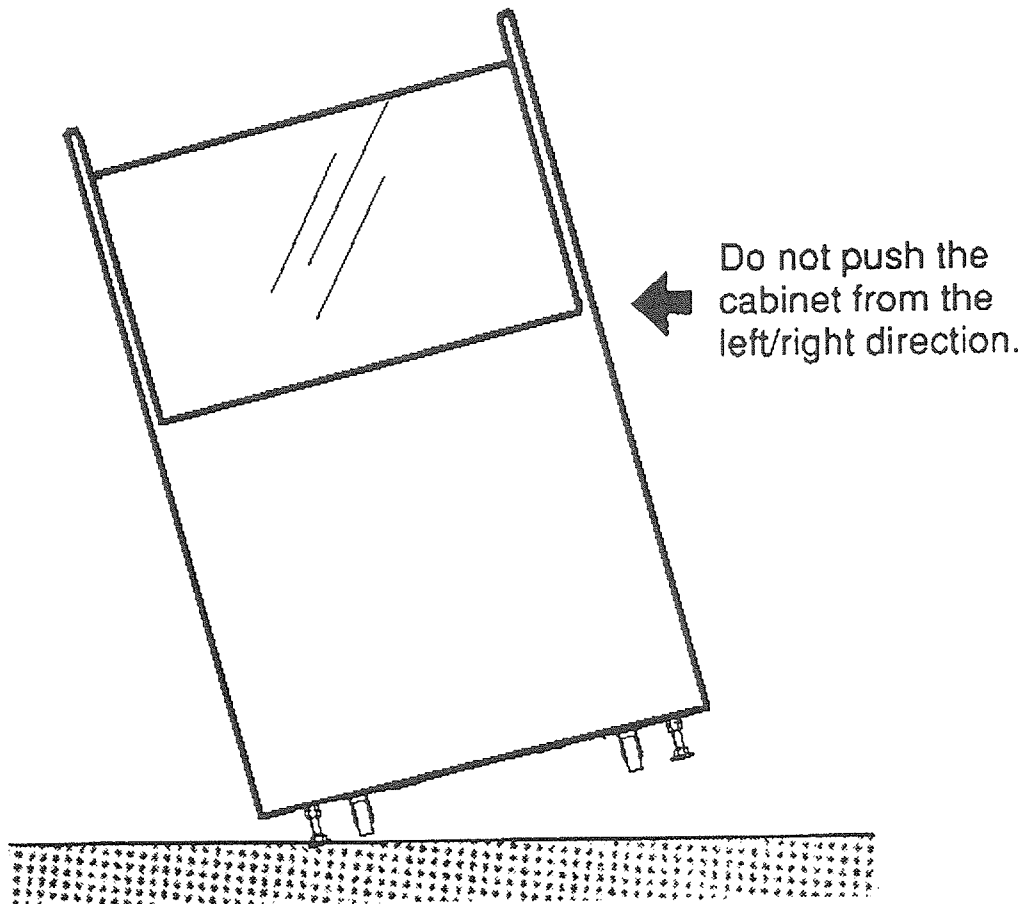

6 . CONTENTS OF GAME

The following explanations apply in the event the product is functioning satisfactorily. Should there be any moves different from the following contents, some sort of faults may have occurred. Immediately look into the cause of the fault and eliminate the cause thereof to ensure satisfactory operation.

When the product is energized, the Billboard's fluorescent lamp is always lit. During the advertise mode, the advertise screen is shown on the monitor and sound is emitted from the speakers. Setting to No Sound Output during the advertise mode is possible in the TEST mode.

OUTLINE OF THE GAME

- This is a single, driving game in which the player competes with rivals by driving a Trailer Truck to cross America.
- When coins are inserted to gain credits, the START button starts flashing. Press the START button to proceed to the SELECTOR mode where you can select your truck and the trailer. The game starts upon selecting the truck and the trailer.
- Based on the setting made in the test mode, the number of coins inserted to obtain a credit counts as one credit in this product. The number of credits necessary to start the game and to continue the game can be set in the test mode.
- The game consists of the 4 kinds of driving stages and 3 kinds of parking stages (Bonus stages).
- When continued, the game is played at the beginning of the last stage that resulted in a game over.
- If your score falls within the top 5, you can enter your name.

CONTENTS OF THE GAME

- Pass the checking point within a certain period of time and reach the goal, and you can clear the stage.
- The game finishes after clearing all 4 stages.
- If you can reach the goal ahead of your rival trailers in each stage (the 1st through the 3rd), then you can play the Parking game (Bonus game).

GAME OVER

- If you fail to pass the checking point within a certain period of time or fail to goal, the game is over.
- Passing the checking point behind the rival trailers or failing on the Parking game does not result in a game over.

OPERATION

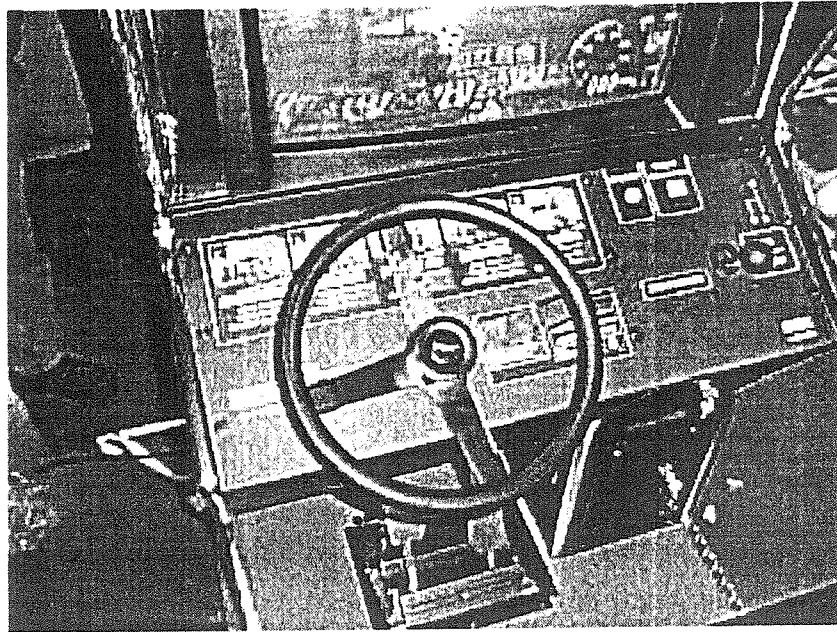

<STEERING WHEEL>

SELECTOR : Turn right or left to select an object.

GAME PLAY : Operate the Trailer Truck.

<HORN AT THE DRIVER'S SEAT>

SELECTOR : Decide

GAME PLAY : Blow the horn to signal the car ahead to move out of the way or to have it increase the speed. Have the trailer ahead increase the speed.

<ACCEL.>

SELECTOR : Decide

GAME PLAY : Increase your Trailer Truck speed, or stop it.

<BRAKE>

SELECTOR : Void

GAME PLAY : Decrease your Trailer Truck speed, or stop it.

<GEAR>

SELECTOR : Void

GAME PLAY : 3-position, HI (High), LOW, R (Reverse)

<VIEW CHANGE>

SELECTOR : Void

GAME PLAY : Select either Driver's View or Bird's View.

<START BUTTON>

The START button flashes when the number of coins that are worth one credit are inserted. While flashing, press the START button to proceed to the SELECTOR. It also flashes when one or more credit(s) remains after the game is over.

SELECTOR

■ **TRUCK SELECT**

Select the truck from among ASPHALT COWBOY, STREAMLINE, HIGHWAY CAT, LONG HORN, and NIHONMARU. Each truck's abilities in SPEED, TORQUE, and TOUGHNESS differ.



■ **TRAILER SELECT**

When starting in stage 2, 3, or 4, select the trailer for towing from the 2 trailers. The weight, the length, and the transportation fee differ. The heavier the trailer, the more the difficulty.

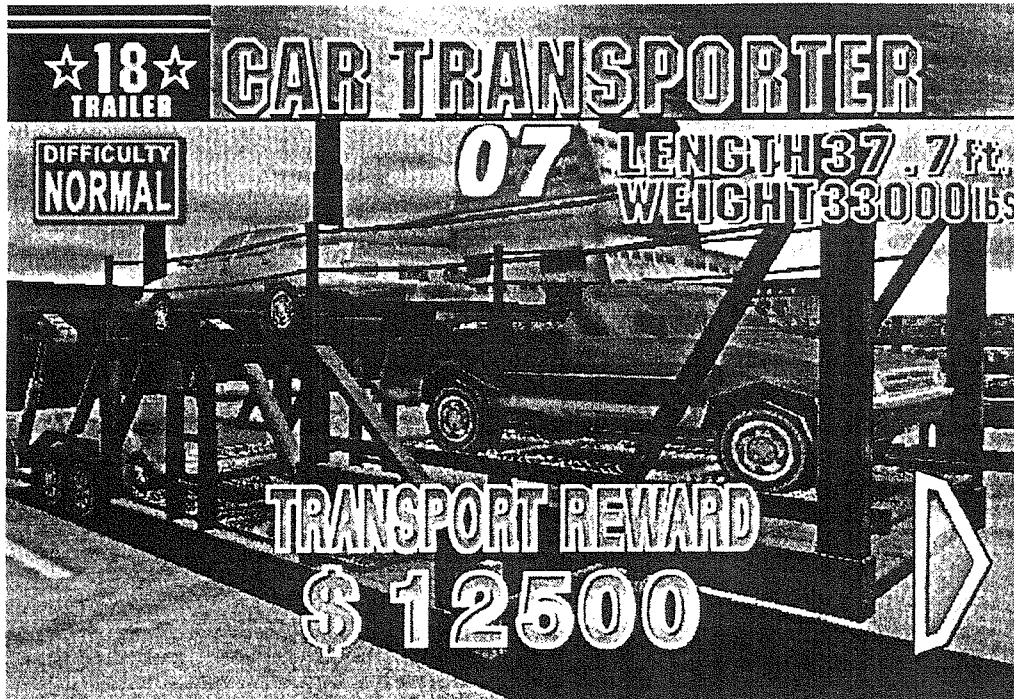

NAME ENTRY

If your score falls within the top 5, you can enter your name.



VIEWING THE GAME SCREEN

REARVIEW MIRROR

DESTINATION

TIME LIMIT



TRANSPORTATION FEE

GEAR CONDITION
GEAR CHANGE INDICATOR

TACHOMETER

<DESTINATION>

Name of the destination point.

<TIME LIMIT>

Indicates the player's playable time. Additional time will be added when passing the CHECKPOINT and obtaining TIME BONUS.

<REARVIEW MIRROR>

Indicates the rear condition while the DRIVER'S VIEW is selected.

<TRANSPORTATION FEE>

Indicates the fee you receive when you reach the destination. If you damage the trailer by hitting another car, etc., the fee will be reduced.

<TACHOMETER>

Indicates the speed of rotation.

<GEAR CHANGE INDICATOR>

Indicates the gear condition (4 positions total) with the lamp on the monitor.

<GEAR CONDITION>

Indicates the current gear condition. The three types of gears (REVERSE - LOW - HI) are available.

7 . EXPLANATION OF TEST AND DATA DISPLAY

By operating the switch unit, periodically perform the tests and data check. When installing the machine initially or collecting cash, or when the machine does not function correctly, perform checks in accordance with the explanations given in this section. The following shows tests and modes that should be utilized as applicable.

A NAOMI GAME BOARD is used for this product. This game board system allows another game board to be played by replacing the ROM Board Case mounted on the NAOMI CASE. As such, the test mode of this system consists of the System Test Mode for the system to execute SELF-TEST, COIN ASSIGNMENTS, etc. used in common for the machines employing the NOMI BOARD, and the Game Test Mode for the specific product to execute Input/Output test for the operation equipment, difficulty setting, etc. In this manual, explanations regarding the System Test Mode cover the settings for this product only. For the details of the System Test Mode, refer to the NAOMI SERVICE MANUAL.

TABLE EXPLANATION OF TEST MODE

ITEMS	DESCRIPTION	CHAPTERS
INSTALLATION OF MACHINE	When the machine is installed, perform the following: 1. Verify that each setting is per the standard settings at the time of shipment. 2. Check all Input equipment in the INPUT TEST mode. 3. Check all OUTPUT equipment in the OUTPUT TEST mode. 4. In the MEMORY TEST mode, check ICs on the IC Board.	SERVICE MANUAL 7-3A 7-3B 4-1
MEMORY	This test is automatically executed by selecting RAM TEST or ROM BOARD TEST in the Menu mode.	SERVICE MANUAL
PERIODIC SERVICING	Periodically perform the following: 1. MEMORY TEST 2. Ascertain each setting. 3. Test all Input equipment in the INPUT TEST mode. 4. Test all Output equipment in the OUTPUT TEST mode.	SERVICE MANUAL 4-1 4-1 7-3A 7-3B
CONTROL SYSTEM	1. Check all Input equipment in the INPUT TEST mode. 2. Adjust or replace all Input equipment. 3. If the problem remains unsolved, check the movement of each control mechanism.	SERVICE MANUAL 7-3B, F 10, 11, 12
MONITOR	In the MONITOR ADJUSTMENT mode, check to see if the MONITOR adjustment is appropriately made.	SERVICE MANUAL 12
IC BOARD	1. MEMORY TEST 2. In the SOUND TEST mode, check the sound related ROMs.	SERVICE MANUAL 4-1, 7-3C
DATA CHECK	Check such data as game play time and histogram to adjust the difficulty level, etc	SERVICE MANUAL 7-3F

7 - 1 SWITCH UNIT AND COIN METER



Never touch places other than those specified. Touching places not specified can cause electric shock and short circuit.



- Adjust to the optimum sound volume by considering the environmental requirements of the installation location.
- If the COIN METER and the game board are electrically disconnected, game play is not possible.

Open the COIN CHUTE DOOR, and the switch unit shown will appear. The function of each switch is as follows:

SWITCH UNIT

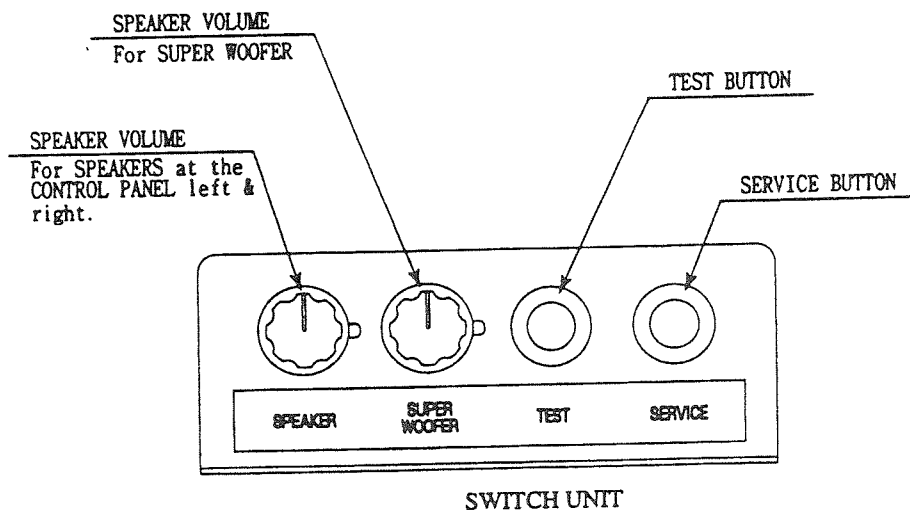

- ① **SPEAKER VOLUME (SPEAKERS)**
Controls the sound volume for the left/right CONTROL PANEL speakers.
- ② **SPEAKER VOLUME (SUPER WOOFER)**
Controls the sound volume for the SUPER WOOFER and the BASE SHAKER under the seat.
- ③ **TEST BUTTON (TEST SW)**
Enters to the test mode.
- ④ **SERVICE BUTTON (SERVICE SW)**
Gives credits without registering on the coin meter.

COIN METER

Open the Cashbox Door by using the key to have the Coin Meter appear underneath the Cashbox.

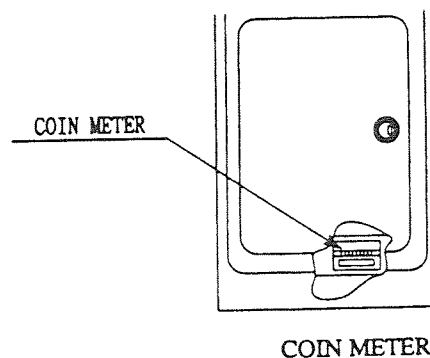

7 - 2 SYSTEM TEST MODE



IMPORTANT!

- The contents of settings changed in the TEST mode are stored when the TEST mode is finished from EXIT in the MENU mode. If the power is turned off before the TEST mode is finished, the contents of the setting changes do not take effect.
- Executing "BACKUP DATA CLEAR" in the SYSTEM TEST MODE does not clear the BOOKKEEPING data in the GAME TEST MODE.
- Entering the TEST mode clears fractional numbers of coins less than one credit and BONUS ADDER data.

The SYSTEM TEST mode mainly allows checks of the IC Board for accurate functioning , monitor adjustment, as well as CRT TEST and COIN ASSIGNMENTS, etc. The following assignments, however, should be designated for this product.

- ◆ CABINET TYPE : 1 PLAYER (S)
- ◆ MONITOR TYPE : HORIZONTAL
- ◆ SERVICE TYPE : COMMON
- ◆ COIN CHUTE TYPE : COMMON

TEST ITEM SELECT

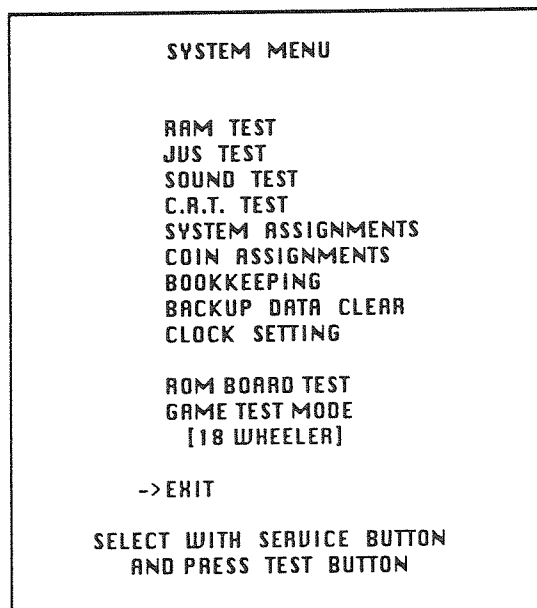

- ① After turning the power on, press the TEST button to display the test item menu shown above.
- ② Press the SERVICE button to move the arrow to the desired item and press the TEST button.
- ③ When finished, bring the arrow to EXIT and press the TEST button to return to the Game mode.

A C.R.T. TEST

1) RGB COLOR ADJUSTMENT SCREEN

In this screen, monitor color can be checked.

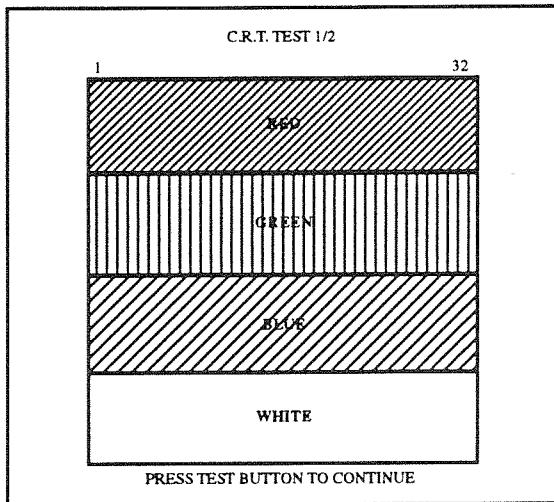

Each of red, green, and blue is the darkest at the leftmost end, and becomes brighter towards the right-hand end in 31 gradations. Monitor brightness is satisfactory if the white color bar is black at the left end and if it is white at the right end. Press the TEST button to proceed to the next screen.

2) MONITOR SIZE ADJUSTMENT SCREEN

In this screen, monitor size can be checked.

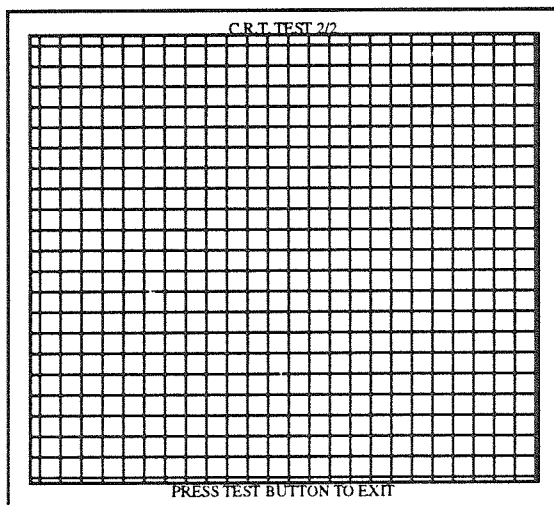

Adjust the crosshatch frame line so that the checkered pattern does not extend beyond the screen. Press the TEST button to return to the menu mode.

B COIN ASSIGNMENTS

The "COIN ASSIGNMENTS" mode permits you to set the start number of credits, as well as the basic numbers of coins and credits. This mode expresses "how many coins correspond to how many credits."

SETTING CHANGE PROCEDURE



IMPORTANT!

Setting changes cannot be stored unless the TEST BUTTON is pressed while the arrow is on EXIT.

- ① Press the SERVICE BUTTON to move the arrow to the desired item.
- ② Change the desired item setting by using the TEST BUTTON.
- ③ To return to the MENU mode, move the arrow to EXIT and press the TEST BUTTON.

```
COIN ASSIGNMENTS

COIN CHUTE TYPE          COMMON (A)
COIN/CREDIT SETTING     #1      (B)
COIN CHUTE #1
1 COIN 1 CREDIT

COIN CHUTE #2
1 COIN 1 CREDIT

MANUAL SETTING           (C)
SEQUENCE SETTING       (D)
-> EXIT

SELECT WITH SERVICE BUTTON
AND PRESS TEST BUTTON
```

(COMMON SETTING)

- (A) COIN CHUTE TYPE (COMMON, INDIVIDUAL)
Set to COMMON.

Up to 2 Coin Chutes (#1 and #2) can be used and also, (B) COIN/CREDIT SETTING ratio can be set separately for #1 and #2.

- (B) COIN/CREDIT SETTING (#1 ~ #27)
Sets the credit increase increment per coin insertion. There are 27 settings from #1 to #27, expressed in $\circ\circ$ credit(s) as against $\circ\circ$ coins inserted. #27 refers to FREE PLAY.

(C) MANUAL SETTING

The Credit's incremental increase settings as against a coin insertion are shown in further details than in (B) above (refer to Table 2). Also, note that when this MANUAL SETTING is performed, (B) COIN CREDIT setting becomes ineffective.

MANUAL SETTING

COIN ASSIGNMENTS MANUAL SETTING		
COIN TO CREDIT	1	(D)
BONUS ADDER	NO BONUS ADDER	(E)
COIN CHUTE #1 MULTIPLIER		(F)
1 COIN COUNT AS 1 COIN		
COIN	1 2 3 4 5 6 7 8 9	
CREDIT	1 2 3 4 5 6 7 8 9	
COIN CHUTE #2 MULTIPLIER		(F)
1 COIN COUNT AS 1 COIN		
COIN	1 2 3 4 5 6 7 8 9	
CREDIT	1 2 3 4 5 6 7 8 9	
SEQUENCE SETTING		(G)
-> EXIT		
SELECT WITH SERVICE BUTTON AND PRESS TEST BUTTON		

(D) COIN TO CREDIT

Determines COIN/CREDIT setting.

(E) BONUS ADDER

This sets how many coins should be inserted to obtain one SERVICE COIN.

(F) COIN CHUTE (#1/#2) MULTIPLIER

This sets how many tokens one coin represents.

Table 1: COIN/CREDIT SETTING (COIN CHUTE COMMON TYPE)

SETTING	FUNCTION OF CHUTE#1	
SETTING #1	1 COIN	1 CREDIT
SETTING #2	1 COIN	2 CREDITS
SETTING #3	1 COIN	3 CREDITS
SETTING #4	1 COIN	4 CREDITS
SETTING #5	1 COIN	5 CREDITS
SETTING #6	1 COIN	2 CREDITS
SETTING #7	1 COIN	5 CREDITS
SETTING #8	1 COIN	3 CREDITS
SETTING #9	1 COIN	4 CREDITS
SETTING #10	1 COIN	5 CREDITS
SETTING #11	1 COIN	6 CREDITS
SETTING #12	2 COINS	1 CREDIT
SETTING #13	1 COIN	1 CREDIT
SETTING #14	1 COIN	2 CREDITS
SETTING #15	1 COIN	1 CREDIT
	2 COINS	3 CREDITS
SETTING #16	1 COIN	3 CREDITS
SETTING #17	3 COINS	1 CREDIT
SETTING #18	4 COINS	1 CREDIT
SETTING #19	1 COIN	1 CREDIT
	2 COINS	2 CREDITS
	3 COINS	3 CREDITS
	4 COINS	5 CREDITS
SETTING #20	1 COIN	5 CREDITS
SETTING #21	5 COINS	1 CREDIT
SETTING #22	1 COIN	2 CREDITS
SETTING #23	2 COINS	1 CREDIT
	4 COINS	2 CREDITS
	5 COINS	3 CREDITS
SETTING #24	1 COIN	3 CREDITS
SETTING #25	1 COIN	1 CREDIT
	2 COINS	2 CREDITS
	3 COINS	3 CREDITS
	4 COINS	4 CREDITS
	5 COINS	6 CREDITS
SETTING #26	1 COIN	1 CREDITS
SETTING #27	FREE PLAY	

Table 2: MANUAL SETTING

COIN TO CREDIT	1 COIN	1 CREDIT
	2 COINS	1 CREDIT
	3 COINS	1 CREDIT
	4 COINS	1 CREDIT
	5 COINS	1 CREDIT
	6 COINS	1 CREDIT
	7 COINS	1 CREDIT
	8 COINS	1 CREDIT
	9 COINS	1 CREDIT

BONUS ADDER	NO BONUS ADDER
	2 COINS GIVE 1 EXTRA COIN
	3 COINS GIVE 1 EXTRA COIN
	4 COINS GIVE 1 EXTRA COIN
	5 COINS GIVE 1 EXTRA COIN
	6 COINS GIVE 1 EXTRA COIN
	7 COINS GIVE 1 EXTRA COIN
	8 COINS GIVE 1 EXTRA COIN
	9 COINS GIVE 1 EXTRA COIN

COIN CHUTE (#1/#2) MULTIPLIER	1 COIN COUNTS AS 1 COIN
	1 COIN COUNTS AS 2 COINS
	1 COIN COUNTS AS 3 COINS
	1 COIN COUNTS AS 4 COINS
	1 COIN COUNTS AS 5 COINS
	1 COIN COUNTS AS 6 COINS
	1 COIN COUNTS AS 7 COINS
	1 COIN COUNTS AS 8 COINS
	1 COIN COUNTS AS 9 COINS

(G) SEQUENCE SETTING

Number of credits required for starting a game, etc. can be set.
Each sequence can be set between 1 ~ 5 credit(s).

**COIN ASSIGNMENTS
SEQUENCE SETTING**

SEQUENCE 1	2 CREDIT(S)
SEQUENCE 2	1 CREDIT(S)
SEQUENCE 3	1 CREDIT(S)
SEQUENCE 4	1 CREDIT(S)
SEQUENCE 5	1 CREDIT(S)
SEQUENCE 6	1 CREDIT(S)
SEQUENCE 7	1 CREDIT(S)
SEQUENCE 8	1 CREDIT(S)

EXIT
[XXXXXX XXXXXX XXXXXX XXXXXX]

DESCRIPTION OF SEQUENCE
1 CREDIT TO START
2 CREDIT TO CONTINUE
3 NO USE
4 NO USE
5 NO USE
6 NO USE
7 NO USE
8 NO USE

**SELECT WITH SERVICE BUTTON
AND PRESS TEST BUTTON**

SEQUENCE 1: Number of credits required for game to start.
SEQUENCE 2: Number of credits required for CONTINUE.
SEQUENCE 3 ~ 8: NOT USED.

7 - 3 GAME TEST MODE

MENU MODE

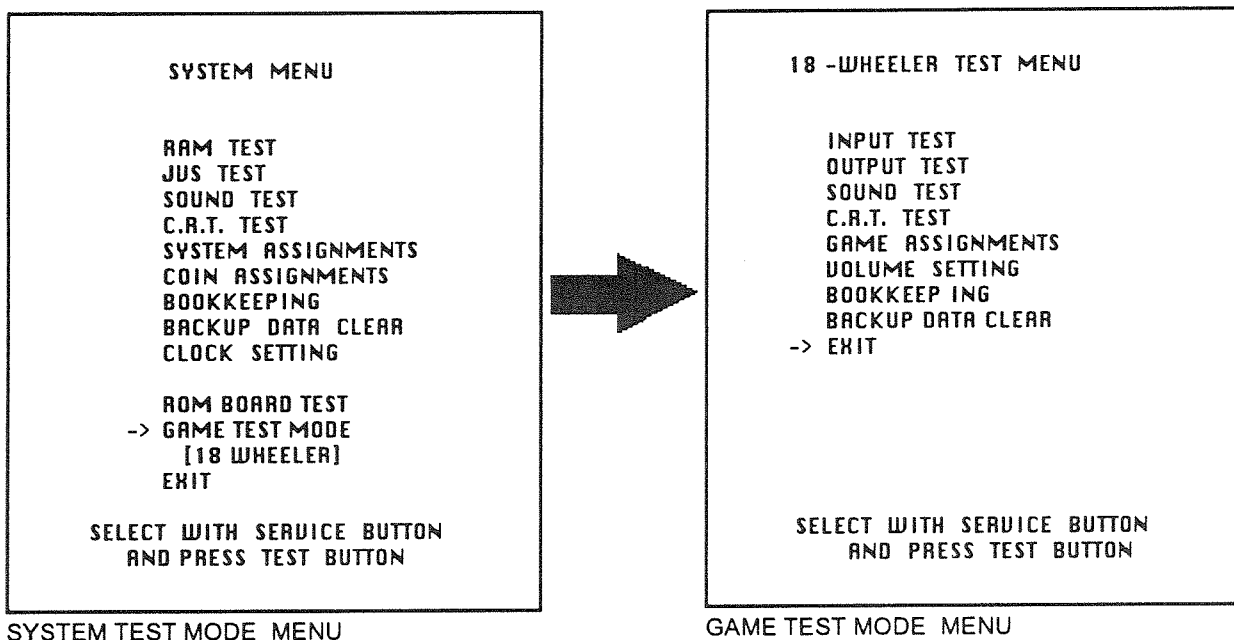

- Press the TEST button to display the SYSTEM TEST MODE MENU.
- By pressing the SERVICE button, move the arrow (->) to select the GAME TEST MODE.
- Press the TEST button to enter GAME TEST MODE. The screen displays the GAME TEST MODE MENU.
- By pressing the SERVICE button, move the arrow (->) to select the desired item. Press the TEST button to execute the selected item.
- Select EXIT and press the TEST button to exit from the GAME TEST MODE and return to the SYSTEM TEST MODE MENU. Further, select EXIT and press the TEST button to finish SYSTEM TEST MODE and return to the normal mode.

A. INPUT TEST

Select INPUT TEST to have the screen shown below appear and to observe the status of each switch on the Control Panel. In this mode, Periodically check the status of each switch.

INPUT TEST	
COIN CHUTE #1	OFF
COIN CHUTE #2	OFF
SERVICE	OFF
TEST	OFF
START	OFF
VIEW	OFF
HORN	OFF
SHIFT [L]	OFF
SHIFT [H]	OFF
SHIFT [R]	OFF
HANDLE	XXX
ACCEL	XXX
BRAKE	XXX

PRESS TEST AND SERVICE BUTTON TO EXIT

- By pressing each switch, if the display on the right-hand side of the name of each switch changes from OFF to ON, the SW and the wiring connections are satisfactory. Operate CONTROL WHEEL, THRUST LEVER, etc. to check Volume value display variation.
- To check COIN CHUTE 1 & COIN CHUTE 2, open the COIN CHUTE DOOR and insert a coin(s) in the slot.
- "HORN" is for the driver seat and the assistant driver seat. Because the same circuit is used for the HORN in both seats, if the switch and the wiring connection are satisfactory, pressing the HORN at either side changes the display from OFF to ON.
- For the steering wheel, the accelerator, and the brake, operate each input device and check to see if the value changes in accordance with operation. Items to be checked :
 Each switch (COIN/SERVICE/TEST/START/VIEW
 CHANGE/HORN/SHIFT<H L R>)
 Each volume (STEERING WHEEL/ACCELERATOR/
 BRAKE)
- Press the TEST BUTTON and the SERVICE BUTTON simultaneously to return to the menu screen.

B. OUTPUT TEST

Select OUTPUT TEST to cause the following screen to appear, and to check the status of each lamp and motor. In this mode, periodically check each lamp and motor.

OUTPUT TEST	
START LAMP	OFF
VIEW LAMP	OFF
HORN LAMP	OFF
ROLL LEFT	OFF
ROLL RIGHT	OFF
-> EXIT	
SELECT WITH SERVICE BUTTON AND PRESS TEST BUTTON	

- Using the SERVICE button, bring the arrow to the desired item and press the TEST button. The display next to the item changes from OFF to ON, and the lamp lights up, or the motor functions.
 LAMP item : If the lamp lights up, operation is satisfactory.
 ROLL LEFT : If the motor moves so as to turn the steering wheel counterclockwise, operation is satisfactory.
 ROLL RIGHT : If the motor moves so as to turn the steering wheel clockwise, operation is satisfactory.
- Bring the arrow to EXIT and press the TEST BUTTON to return to the menu screen.

C. SOUND TEST

Selecting the SOUND TEST displays the following screen on the monitor. This test mode allows each sound used in the game to be checked.

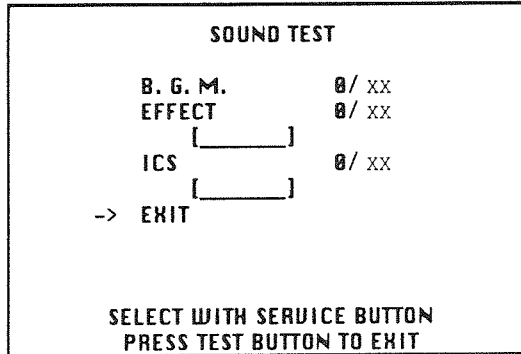

- Press the SERVICE button to move the arrow and select an item. Every time the TEST button is pressed, a different sound is played.
B. G. M. : Sounds used in the game can be played.
EFFECT : Sound effects used in the game can be played.
ICS : Sound effects in a loop used in the game can be played
- Bring the arrow to EXIT and press the TEST button to return to the MENU screen.

D. GAME ASSIGNMENTS

Selecting the GAME ASSIGNMENTS in the MENU mode causes the present game settings to be displayed and allows game setting changes (game difficulty, etc.) to be made. After setting changes, be sure to exit from the TEST mode; the settings are not renewed until the TEST mode is exited.

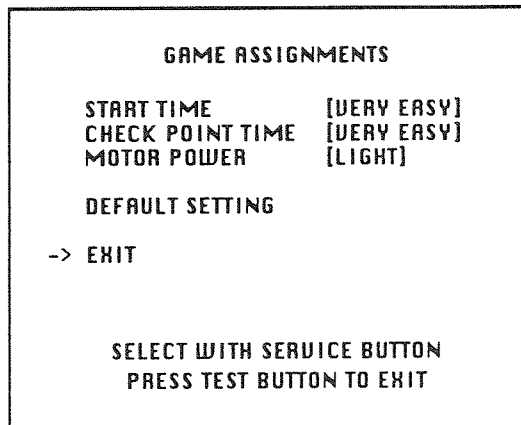

- START TIME : The time limit given to the player at the beginning of the stage can be set. Select from VERY EASY, EASY, NORMAL, HARD, and VERY HARD.
- CHECK POINT TIME : The additional time given to the player when passing the CHECK POINT can be set.
- MOTOR POWER : The feedback stiffness of the steering wheel can be selected from LIGHT, NORMAL, and HEAVY.
- DEFAULT SETTING : This makes each setting return to its default setting.

Bring the arrow to EXIT and press the TEST button to return to the MENU screen.

E. VOLUME SETTING

Selecting the VOLUME SETTING displays the following screen on the monitor. The volume of the detection for the steering wheel operation can be manually set. The value will be stored upon exiting from the item.

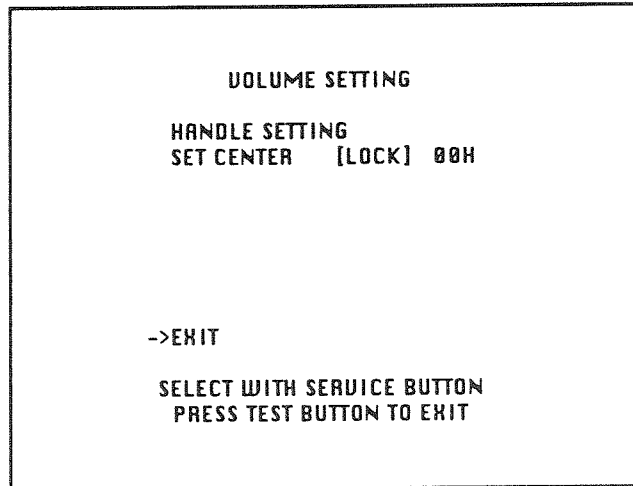

SETTING THE STEERING WHEEL VOLUME

- ① Press the SERVICE button to bring the arrow to SET CENTER.
- ② "SET CENTER [LOCK]" display changes to "SET CENTER [SET]."
- ③ Manually bring the steering wheel to the centering position.
- ④ Press the TEST button. The Volume value obtained at this time is stored as the steering wheel's centering value, and "SET CENTER [LOCK]" is displayed. If the value does not fall within 80+/- 5H at this time, perform volume adjustment by referring to 7-3E (above).

Bring the arrow to EXIT and press the TEST button to return to the MENU screen.

F. BOOKKEEPING

Selecting BOOKKEEPING in the MENU mode displays the data of the present operating status on 2 pages. Press the TEST button to proceed to the next screen. Pressing the TEST button while the second page is showing returns the screen to the MENU mode.

```
BOOKKEEPING      1/2
NUMBER OF GAMES      0
NUMBER OF CONTINUE   0
AVERAGE PLAY TIME   00M00S

PRESS TEST BUTTON TO CONTINUE
```

- NUMBER OF GAMES : Total number of plays.
- NUMBER OF CONTINUE : Total number of continues.
- AVERAGE PLAY TIME : Refers to the average game play time.

```
BOOKKEEPING      2/2
TIME HISTOGRAM
00M00S - 00M29S ----- 0
00M30S - 00M59S ----- 0
01M00S - 01M29S ----- 0
01M30S - 01M59S ----- 0
02M00S - 02M29S ----- 0
02M30S - 02M59S ----- 0
03M00S - 03M29S ----- 0
03M30S - 03M59S ----- 0
04M00S - 04M29S ----- 0
04M30S - 04M59S ----- 0
05M00S - 05M29S ----- 0
05M30S - 05M59S ----- 0
06M00S - 06M29S ----- 0
06M30S - 06M59S ----- 0
OVER      07M00S ----- 0

PRESS TEST BUTTON TO EXIT
```

- In Page 2/2, Histogram of Number of Play as against Play Time is displayed.
- By-playtime play frequency bookkeeping is displayed in increments of 30 seconds from 00M00S to 06M59S. Playtime in excess of 7 minutes is displayed all in the category of OVER 07M00S.

G. BACKUP DATA CLEAR

Selecting the BACKUP DATA CLEAR displays the following screen on the monitor. In the GAME TEST MODE, this allows the contents of BOOKKEEPING and Player Ranking data to be cleared. The COIN/CREDIT related data can be cleared in the BACKUP DATA CLEAR in the SYSTEM TEST MODE.

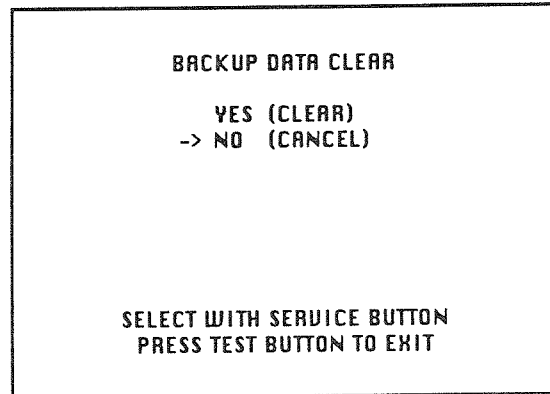

- When clearing, use the SERVICE BUTTON to bring the arrow to “YES (CLEAR)” and press the TEST BUTTON.
- “YES (CLEAR) COMPLETED” will be displayed, and “COMPLETED” will be flashing. When the data has been cleared, the display will stop flashing. After the data has been cleared, bring the arrow to “NO (CANCEL)” and press the TEST BUTTON to return the screen to MENU mode.
- Note that despite the “clear” execution, the settings of the GAME ASSIGNMENTS and VOLUME SETTINGS do not change.

8. HANDLE MECHA



WARNING!

- Be sure to turn power off before performing work, and avoid touching undesignated places. Failure to do so can result in electric shock and short circuit accidents.
- Be careful so as not to damage wirings. Damaged wiring can cause electric shock and short circuit hazards.
- Do not insert hand(s) into the mechanism so as not to cause hand(s) and fingers to be caught. Doing so can result in serious injury.
- When performing work such as parts replacement other than those specified in this manual, be sure to contact the company the product was purchased from and confirm the work procedures and find out any precautions prior to performing the work. Inappropriate parts replacement and/or installing with improper adjustment can cause an overload or the parts to come into contact, resulting in electric shock, short circuit, or fire.



CAUTION!

When putting on the HANDLE MECHA, do not put the gear or the sensor portion face down. Failure to observe this may damage the parts due the weight of the mechanism.



IMPORTANT!

Be sure to perform the Volume value setting under Volume Setting in the Test Mode after replacing or adjusting the Volume.

8 - 1 REMOVING THE CONTROL MECHANISM

If the Steering operability is poor and the adjustment of VOLUME SETTING in the TEST mode is ineffective, the cause may be failure of the Volume Gear's mesh and/or Volume malfunctioning. By using the following procedure, adjust the Volume gear mesh, or replace the Volume. In this product, when the Steering Wheel is moved all the way to the left/right, and the Volume shaft rotates within the movable range, then the Volume is probably not damaged. When securing the Volume, be sure the Volume shaft is oriented as shown and the gears are appropriately engaged when the steering wheel is in the center position, allowing the truck to go straight forward.

In order to replace or adjust the V.R., remove the HANDLE MECHA as per the following procedure.

- ① Turn the power off.
- ② Take out the 4 truss screws at the center of the steering wheel to remove the FRAME HORN BUTTON, CUSHION U and the CAP HORN BUTTON. A small part (called the PIN HORN BUTTON) is attached to the CAP HORN BUTTON. Be sure to keep it.
- ③ Pull out the ROD HORN BUTTON.
- ④ Remove the SPRING and the CUSHION L.
- ⑤ Take out the hexagon nut.
- ⑥ Remove the WASHER HANDLE SHAFT.
- ⑦ Pull the STEERING HANDLE out of the HANDLE SHAFT. The HANDLE and the SHAFT are a nesting of the gear-shaped spline holes and the shaft. Be sure to pull the STEERING HANDLE vertically so as not to damage the shaft.
- ⑧ Remove the COLLAR from the HANDLE SHAFT.

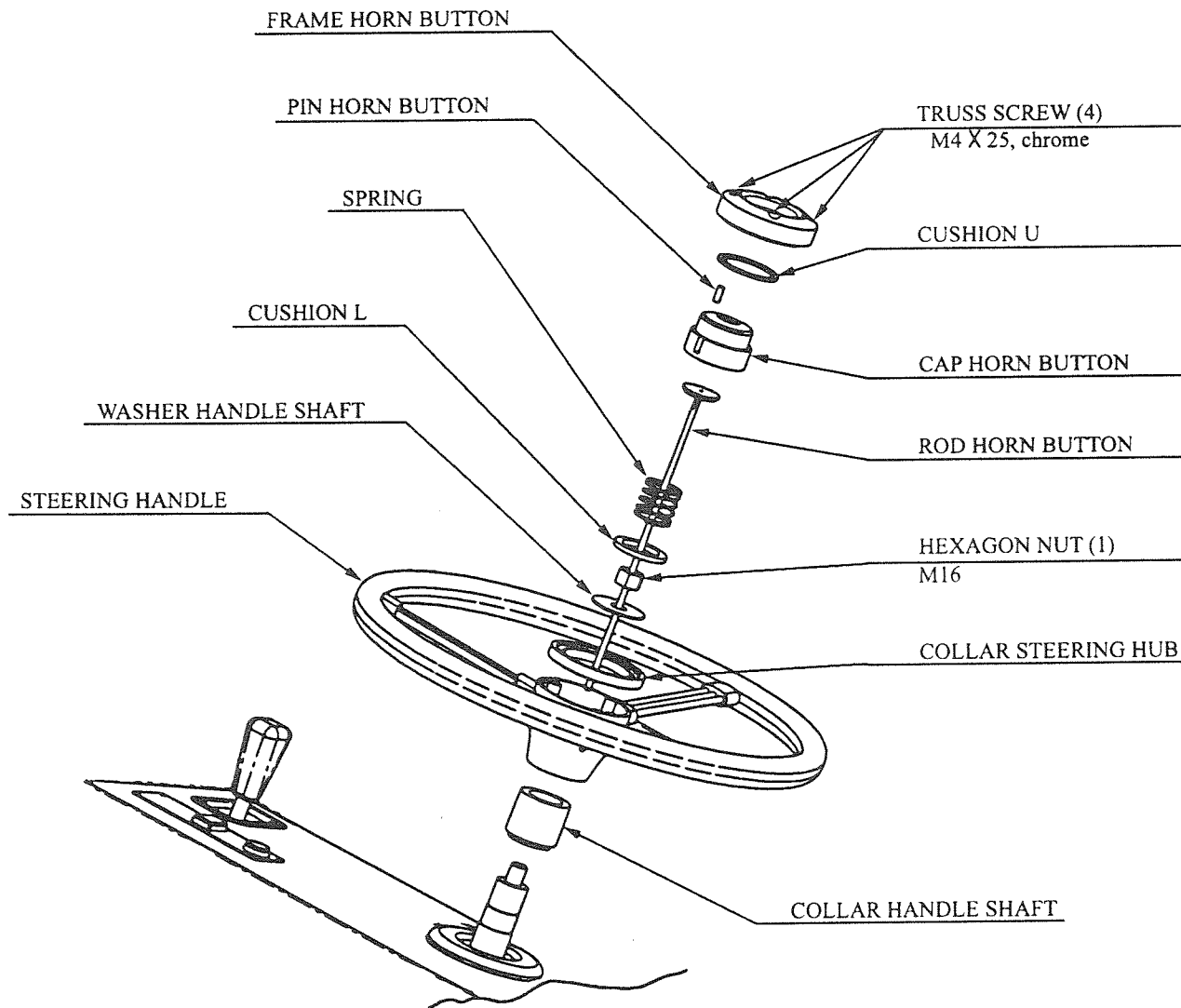

- ⑨ Remove the 4 Tamperproof screws, and the 4 Phillips screws (8 total) on the angled metal plate located in front of and below the control panel. Remove the panel.
- ⑩ Take out the 8 Tamperproof screws to remove the CONTROL PANEL. Use care so as not to damage the wiring inside the CONTROL PANEL COVER.
- ⑪ Disconnect the 2 connectors inside the CONTROL PANEL, and remove the CONTROL PANEL.
- ⑫ Disconnect the HANDLE MECHA's wire connectors (to the Horn and Start Button)

⑬ Remove the HANDLE MECHA. Use **CAUTION** when performing this task.

⑭ When setting down the HANDLE MECHA, be sure to have the gear and sensor portions face up. Failure to do so may damage the parts due to the weight of the mechanism.

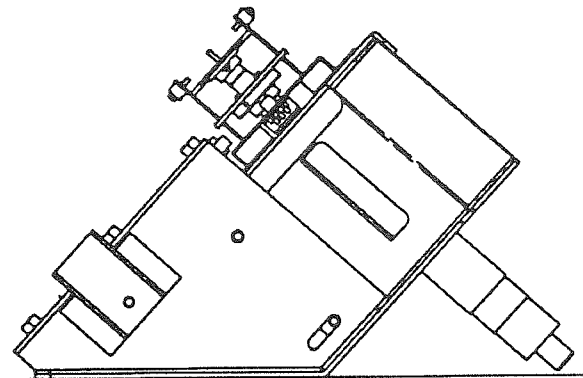
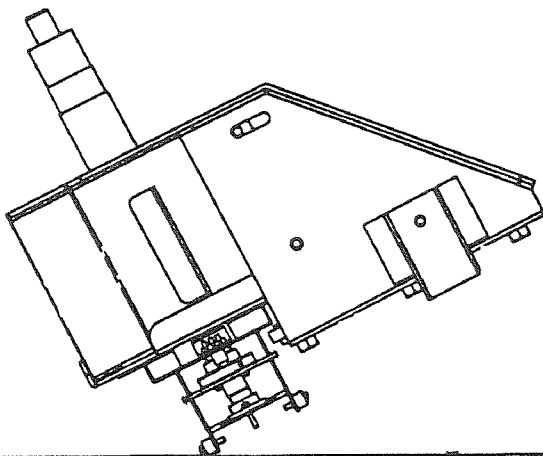
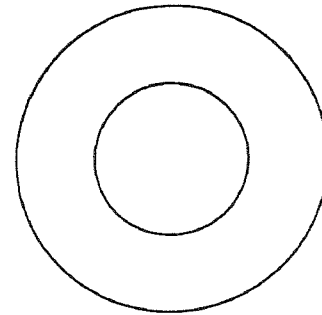
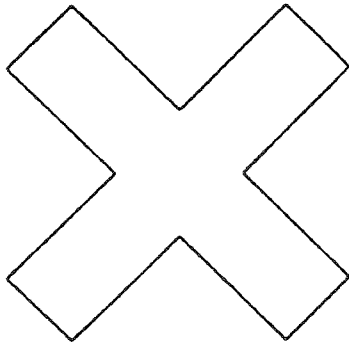

(may not appear as shown)

8 - 2 VOLUME ADJUSTMENT/REPLACEMENT



- Never touch places other than those specified. Touching unspecified places can cause electric shock and/or short circuit.
- After the replacement or adjustment of the VR, be sure to set the variable value of the VR in the test mode's Volume Setting.

Volume adjustment/replacement should be performed after the HANDLE MECHA has been removed as per 8 - 1.

ADJUSTMENT

- ① In order to turn the HANDLE SHAFT, insert the STEERING HANDLE into the HANDLE SHAFT.
- ② Secure the HANDLE at the centering position.
- ③ Loosen the 2 screws which secure the VOLUME BRACKET to push the gear out of mesh.
- ④ With the HANDLE SHAFT at the centering position, bring the gear into mesh so that the position of the volume's shaft is as shown in the Fig.
- ⑤ Fasten the screws securing the VOLUME BRACKET.
- ⑥ After the work is finished, perform Volume Setting in the Test mode.

"D" CUT FACE (HANDLE SHAFT)

"D" CUT FACE (VOLUME)

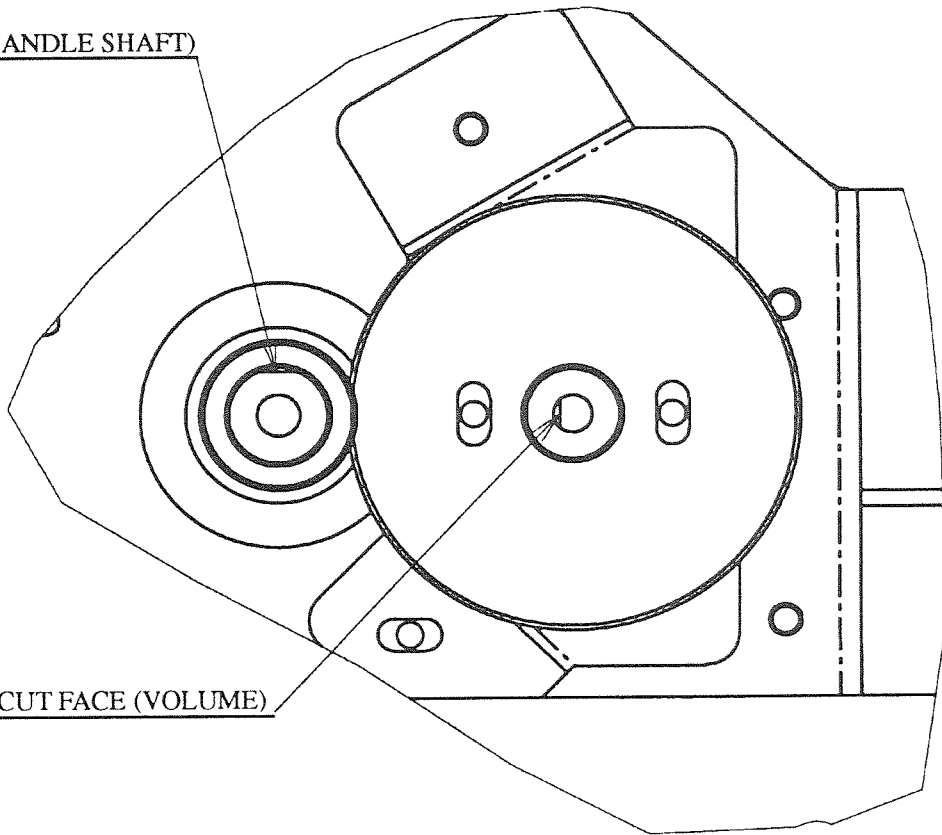

REPLACEMENT

- ① Disconnect the wiring connector.
- ② Take out the 2 screws which secure the VOLUME BRACKET to remove the BRACKET together with the Volume.
- ③ Take out the 2 screws, remove the Volume Gear, and replace the Volume.
- ④ With the HANDLE SHAFT at the centering position, bring the gear into mesh so that the position of the volume's shaft is as shown in the Fig.
- ⑤ Fasten the screws securing the VOLUME BRACKET.
- ⑥ After the work is finished, perform Volume Setting in the TEST mode.

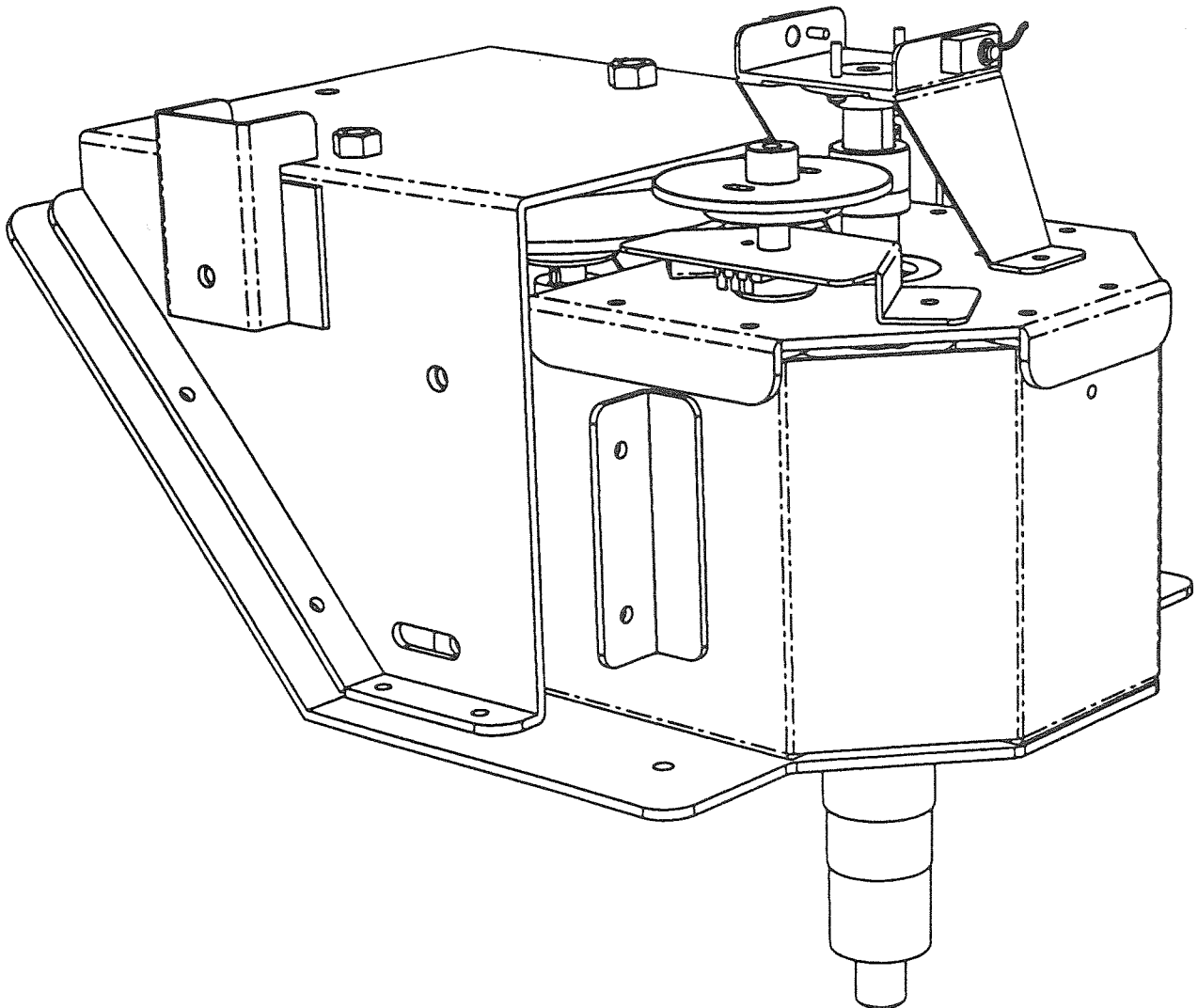

MAY NOT APPEAR AS SHOWN

9. SHIFT LEVER



WARNING!

- In order to prevent electric shock and short circuit, be sure to turn off the power before performing work on the interior parts of the product.
- Be careful not to damage wiring. Damaged wiring can cause electric shock or short circuit.
- Do not touch places other than those specified. Touching unspecified places can cause an electric shock or short circuit.

If the Shift Lever operation is not satisfactory, remove the Shift Lever according to the following procedure and replace the microswitch.

9 - 1 REMOVING THE SHIFT LEVER

- ① By following "8-1 REMOVING THE HANDLE MECHA", turn the power off, remove the STEERING HANDLE, and remove the CONTROL PANEL COVER.
- ② Take out the 4 Hexagon Bolts.

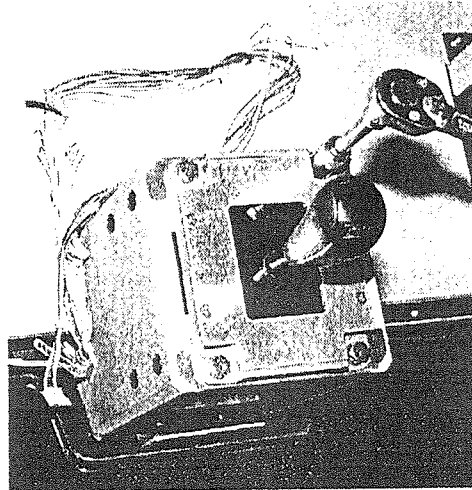

- ③ Pull up the SHIFT LEVER slowly until the 2 wiring connectors can be seen.
- ④ Disconnect the 2 connectors.

